

McLeod®

Clutches • Flywheels • Discs • Components

Celebrating 45 years as the leader in
[High Performance Driveline Components](#)



2016
Interim
Product Guide

ABOUT THE OWNER



At McLeod we are very proud that our owner and president, Paul Lee, shares our customers' passion for cars and for speed.

Paul started racing at a young age when he would sneak his mom's car, a Plymouth Duster, to Atco Dragway on Friday nights. That was the start of a journey that would see Paul rise through the ranks of racing all the way to NHRA Top Fuel Funny Car.

His background in finance and management gives him great skills to run McLeod but his passion for the industry is what gives him his drive.

When you buy from McLeod you can rest assured that we would not sell you any part that Paul wouldn't use in one of his own cars.



TABLE OF CONTENTS

New Products	4
Supremacy Sport Compact Clutches.....	8-9
Performance Street Guide	10-54
Clutch Kit Assemblies – Cars	14-45
Clutch Kit Assemblies – Trucks	46-51
Custom Street Twin Assemblies	52-54
Flywheel Application Guide	55-60
Street Disc Buyers Guide	62-64
Street Disc Buyers Guide & Pilot Bearings	64
Bolts & Pilot Tools	65
Racing Assemblies	66-68
Line Launch	69
Race Product Guide	70-86
Soft Lok Assemblies & Parts	70-73
Mag Force Assemblies & Parts	74-79
Sport Compact Mag Force Assemblies & Parts	80
Pro Series Assemblies	82-83
Pull Truck Assemblies & Parts	84-86
Racing Discs	87
Racing Pressure Plate Application Guide	88-89
Throw-Out Bearings.....	90-98
Bellhousings	100-101
Muscle Car 5 Transmission	104-105
TREMEC Transmissions	106
Clutch 101	108-109
Clutch Troubleshooting	110-111
Clutch FAQ's	112-113
Hydraulics 101	114-115
Throw-Out Bearing & Adjustment Info	116
Clutch and Flywheel Repairs	117
McLeod Headquarters	118-119
Terms & Policies	121

NEW PRODUCTS

New Products

McLeod 6.1 SFI Approved Spun Aluminum Bellhousing

The McLeod's Aluminum SFI 6.1 Approved Bellhousing weighs only 13.5 lbs. But don't let that lightweight give the impression that bellhousing is a lightweight. Added protection is provided via a steel inner liner.

- Available for both Ford and GM applications
- GM version 13.5 lbs
- Ford version 14 lbs.
- Available with TMS Titanium liner

For more info
please refer to page 100.



RXT1200 Twin Disc

The RXT 1200 is the newest member of McLeod's world famous twin disc line-up. The RXT1200 has all of the same great features as the RXT with the added benefit of a higher clamp load pressure plate for an incredible 1200HP of holding power.

- Slightly Firmer pedal Feel Than RXT
- Smooth Engagement
- Patented Adapter Ring For Most Applications
- Great Holding Power For An Excellent Value.

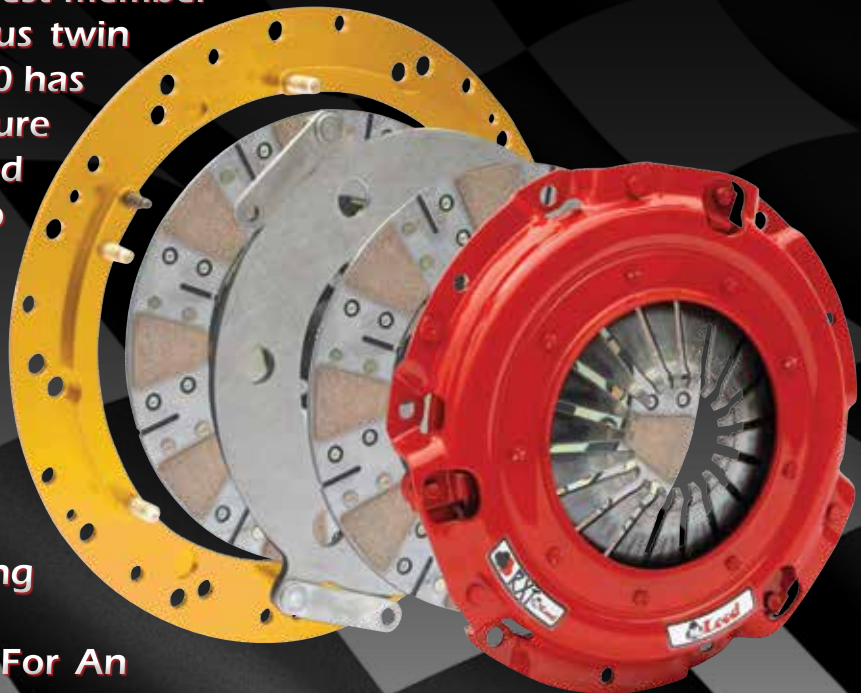

Supremacy Street Supreme Clutch Kits

The Street Supreme is design for higher horsepower sport compact and European cars. It is a great clutch for both the street and the track.

- High Clamp load Pressure plate
- High Torque 6 Puck Disc With Sprung Hub
- Superior Holding Power and Smooth Engagement



The Next Generation Mag Force

We have now added optional adjustable stands to the Mag Force to give clutch tuners that added advantage. The pressure plate has been redesigned for added strength and we have made the diaphragm a bolt in design so it can be serviced at the track.

- Available In Single, Twin & Triple Configurations
- Available In Strapped Version For Quiet & Clean Release
- Available in Pin Drive Version For Quick Release
- Available for domestic and sport compact applications

For more info please refer to page 67.

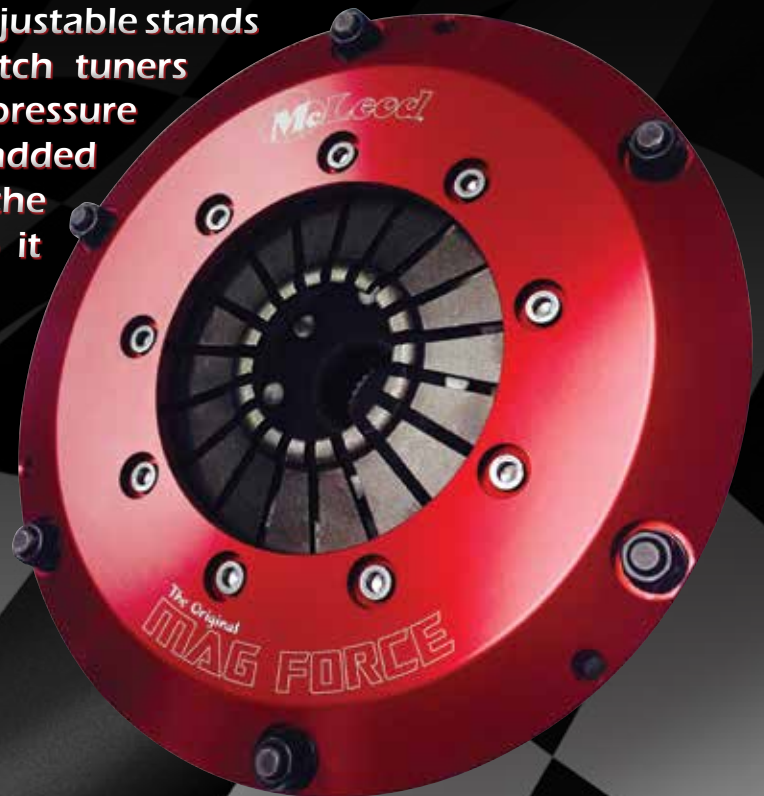

NEW PRODUCTS

New Products

Dodge Diesel Truck Clutch Kits

As a part of our updated WorkHorse clutch lineup McLeod has added numerous diesel truck applications including the Dodge Cummins Diesel.

The WorkHorse kits for Dodge Diesel applications are available in different diameters and disc material options.

They also come as a complete kit including a performance steel flywheel.



Diesel Application Guide

Model	Engine	Years	Flywheel Material	Spline	Footnote
Ram 2500	5.9L L6 DIESEL	1998-2002	Steel	1 1/16" x 10	5 Speed & 2000 6 Speed
Ram 2500	8.0L 488ci V10 GAS	1998-2003	Steel	1 1/16" x 10	
Ram 3500	5.9L L6 DIESEL	1998-2002	Steel	1 1/16" x 10	5 Speed & 2000 6 Speed
Ram 3500	8.0L 488ci V10 GAS	1998-2003	Steel	1 1/16" x 10	
Part Number		Description			Torque Rating
78232		13" HD Pressure Plate with Ceramic Disc w/Flywheel			1150
78231		13" HD Pressure Plate with Organic Disc w/Flywheel			750
78132		13" STD Pressure Plate with Ceramic Disc w/Flywheel			1000
78131		13" STD Pressure Plate with Organic Disc w/Flywheel			640
78222		12 1/4" HD Pressure Plate with Ceramic Disc w/Flywheel			1025
78221		12 1/4" HD Pressure Plate with Organic Disc w/Flywheel			680
78122		12 1/4" STD Pressure Plate with Ceramic Disc w/Flywheel			900
78121		12 1/4" STD Pressure Plate with Organic Disc w/Flywheel			600
Note: 13" Can Be Used In Place Of O.E. 12 1/4"					

Street Level and Street Extreme Clutch Kits

McLeod Street Level and Street Extreme clutch kits include a high clamp load pressure plate for increased holding power. The Street Level has an organic disc for smooth engagement. The Street Extreme has a ceramic disc for added holding power.

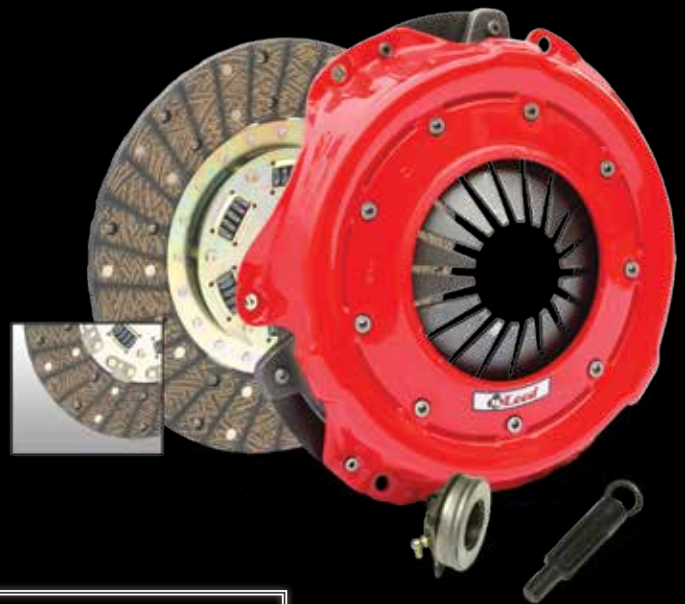

- Street Level for cars with mild bolt ons.
- Street Extreme for cars with up to 600 h.p.

Application Guide

Make	Part Number Street Level	Part Number Street Extreme	Application	Dia.	Spline	Pressure Plate Style
Ford	75001	75301	2005-2010 Mustang GT	11'	1 1/16" x 10	Diaphragm
	75004	75304	2001-2004 Mustang GT 1999-2004 Mustang Cobra	11"	1 1/16" x 10	Diaphragm
	75005	75305	1986-2001 Mustang GT 1993-1998 Cobra	10.5	1 1/16" x 10	Diaphragm
	75007	75307	1986-2001 Mustang GT 1993-1998 Cobra	10.5	1 1/16" X 26	Diaphragm
	75012	75312	1968-1974 Ford	11"	1 1/16" x 10	Diaphragm
	75043	75343	Ford Truck	11"	1 1/16" x 10	Diaphragm
GM	75016	75316	1993-1997 Camaro & Firebird	11"	1 1/16" X 26	Diaphragm Pull Style
	75017	75317	1955-1983	10.5	1 1/8" x 10	Diaphragm
	75025	75325	1971-1975	10.5	1 1/8" x 26	Diaphragm
	75024	75324	1955-1979 V8	11"	1 1/8" x 10	Diaphragm
	75021	75321	1955-1985 V8	11"	1 1/8" x 26	Diaphragm
MOPAR	75008	75308	1971-1979	11"	1" x 23	Diaphragm
	75009	75309	1965-1999	10.5	1" x 23	Diaphragm
	75038	75338	Mopar	10.95	1" x 23	B&B 6 Roller

SUPREMACY SPORT COMPACT CLUTCH KITS

Sport Compact Clutch Kits

Street Tuner

- The Street Tuner Clutch Kit is perfect for street cars with mild bolt-ons
- High Quality Matched Pressure Plate
- Advanced Steel Backed Disc
- Higher Clamping Load & Burst Strength

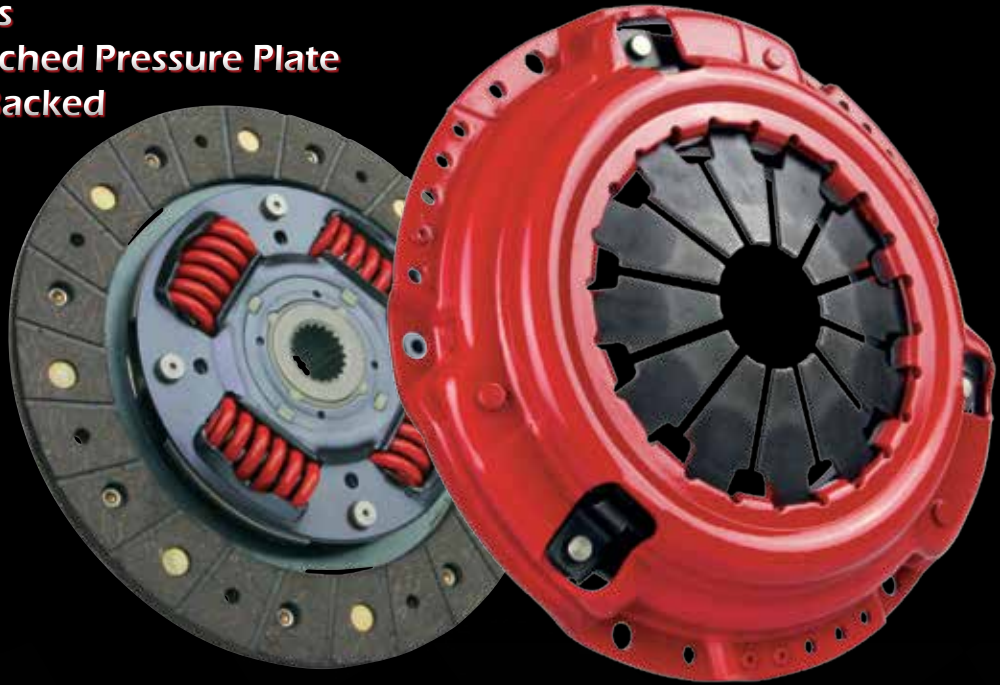

Street Power

- The Street Power Clutch Kit is perfect for street/track cars with moderate bolt-ons
- High Quality Matched Pressure Plate
- High Torque 6 Puck Carbotic Disc
- Higher Clamping Load & Burst Strength

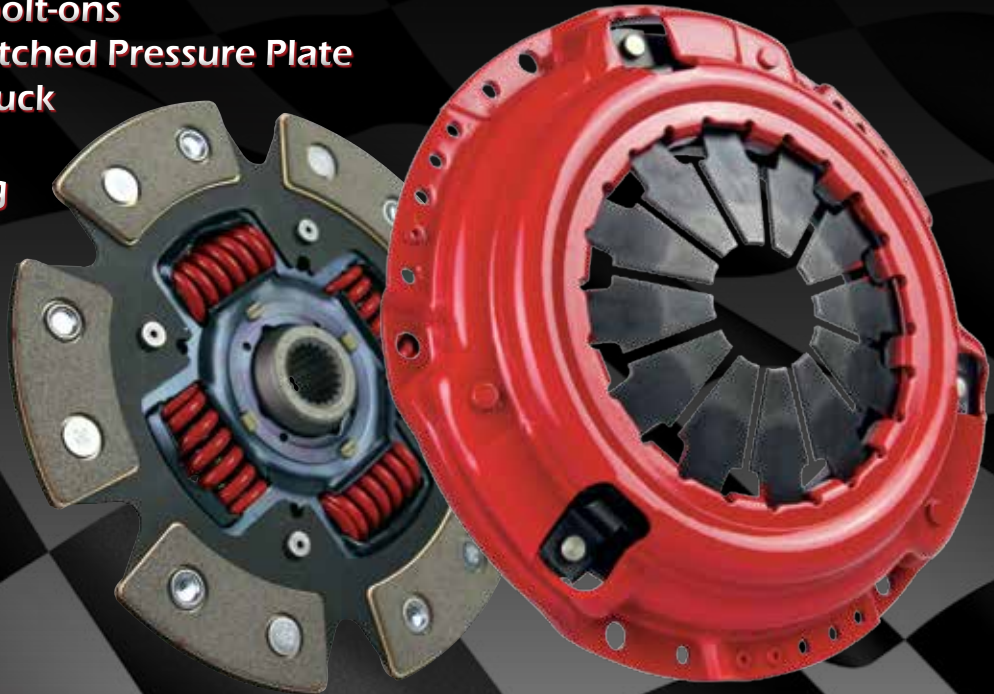

SUPREMACY SPORT COMPACT CLUTCH KITS

Street Elite

- The Street Elite Clutch Kit is perfect for street cars with moderate bolt-ons
- High Clamp Load Pressure Plate
- Sprung Hub Carbon/Organic Disc
- Superior Holding Power and Smooth Engagment



Sport Compact Clutch Kits

Street Supreme

- The Street Supreme Clutch Kit is perfect for street/track cars with moderate bolt-ons
- High Clamp Load Pressure Plate
- High Torque 6 Puck Carbotic Disc
- Superior Holding Power and Smooth Engagment

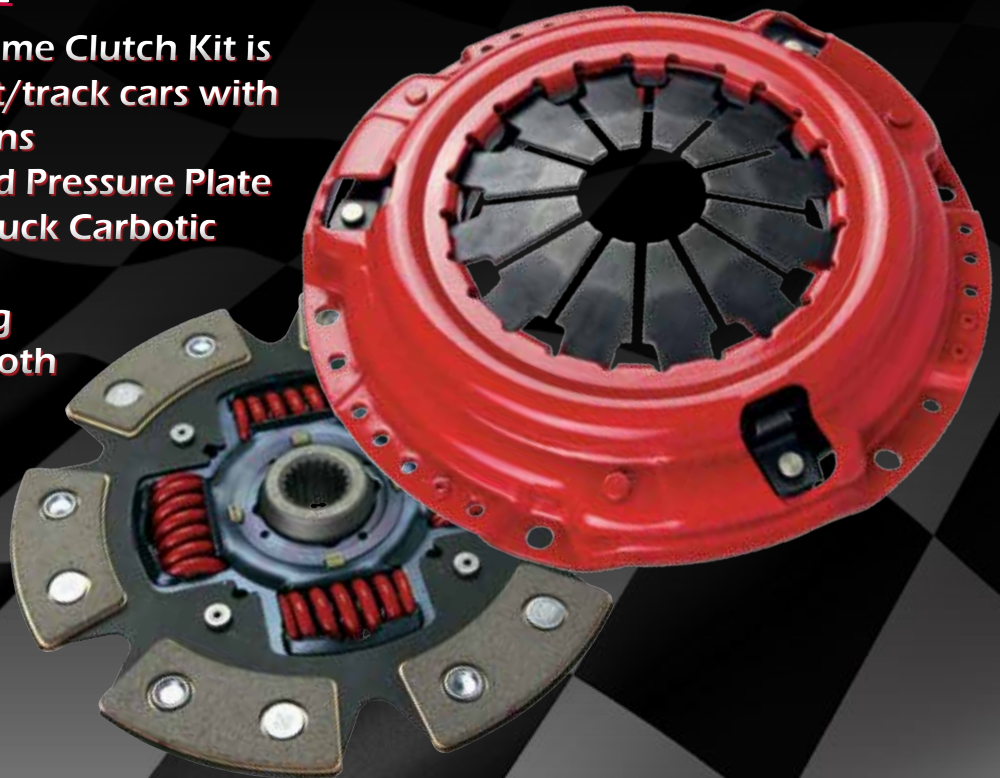

STREET CLUTCH KITS

Street Pro

Street Clutch Kits

The Street Pro clutch kit is an excellent entry-level clutch replacement for street enthusiasts. This is an ideal application for use with basic performance modifications and street tires.

**Sprung Hub Organic Disc
Excellent Street Clutch**



UP TO 400HP

**Kit Includes:
Pressure Plate
Organic Style Disc
Throwout Bearing
Pilot Tool.**

Super Street Pro

The Super Street Pro clutch kits are great street strip performance clutches for increased street performance. This is a great application to use with moderate engine modifications and street tires.

**Sprung Hub Dual Friction Disc
Excellent Street and Entry Level
Track Clutch**



UP TO 550HP

**Kit Includes:
Pressure Plate
Dual Faced Disc
Throw Out Bearing
Pilot Tool**

STREET CLUTCH KITS

RST

The RST Street Twin Clutch Assembly is the economical solution to high horsepower street engines. The RST can handle up to 800 HP while still maintaining a stock pedal effort. Since this assembly adapts to most applications there is no need to purchase a new flywheel, which considerably lowers the overall cost of the unit.



Street Clutch Kits

Kit includes:
Pressure Plate
Two Organic Friction Discs
Floater Plate
Flywheel Adaption Ring
Alignment Tool

Up To 800HP

The RXT Street Twin Clutch Assembly is the solution to extreme street-able horsepower. The RXT can handle up to 1000 HP while still maintaining light pedal effort and excellent street characteristics. Since this assembly adapts to most applications, there is no need to purchase a new flywheel, which considerably lowers the overall cost of the unit.

RXT



Kit includes:
Pressure Plate
Two Ceramic Friction Discs
Floater Plate
Flywheel Adaption Ring
Alignment Tool

Up To 1000HP

STREET CLUTCH KITS

Street Clutch Kits

The RXT 1200 Street Twin Clutch Assembly is the solution to extreme street-able horsepower. The RXT 1200 can handle up to 1200 HP while still maintaining light pedal effort and excellent street characteristics. Since this assembly adapts to most applications, there is no need to purchase a new flywheel, which considerably lowers the overall cost of the unit.

Kit includes:

- Pressure Plate
- Two Ceramic Friction Discs
- Floater Plate
- Flywheel Adaption Ring
- Alignment Tool

RXT 1200



Up To 1200HP

Street Twin

Up To 1400HP

In 1974 with the rising popularity of power adders such as Nitrous, Superchargers & Turbochargers, McLeod recognized the need for a clutch assembly that was street friendly, yet still capable of handling up to 1,400 horsepower, thus the Street Twin was born!



up to 1200 h.p. with organics discs

up to 1400 h.p. with ceramic discs

For ceramic discs, please contact McLeod.

Specially Designed Performance Flywheel Included

Aluminum Flywheel

Aluminum flywheels are ideal for numerous applications such as supercharged or turbocharged engines. These flywheels are ideal for higher horsepower engines and combinations that achieve rapid RPM levels.



CNC Machined 6061 T6 Aluminum
Replaceable Steel Friction Plate
1045 Steel Hardened Ring Gear

Steel Flywheel

The steel flywheel is perfect for street applications where easy stop light acceleration is desired and for off road or rock crawling. Our steel flywheels are available in various weights. For race applications, a heavier steel unit is ideal for helping launch a heavy car with a smaller engine with less torque and horsepower.

CNC Machined From Billet Steel Alloy
1045 Steel Hardened Ring Gear
Most Units Have Multiple Clutch Patterns



PERFORMANCE STREET GUIDE

Clutch Kit Assemblies Application Guide - Cars

Make & Model	Engine	Year	Vehicle Option	Foot Note	Type	Stock Size	Spline
BUICK							
Apollo	5.7L (350ci) V8	1973			Diaph	10.5"	1-1/8" x 10
		1973			Diaph	11"	1-1/8" x 10
Centurion	5.7L (350ci) V8	1971-1973			Diaph	10.5"	1-1/8" x 10
		1971-1973			Diaph	11"	1-1/8" x 10
	7.5L (455ci) V8	1971-1973			Diaph	10.5"	1-1/8" x 10
		1971-1973	With 4 Speed, 4 Barrel Carburetor		Diaph	11"	1-1/8" x 26
Century	6 Cylinder						
	3.8L (231ci) V6	1979-1981			Diaph	10.5"	1-1/8" x 10
	8 Cylinder						
	5.7L (350ci) V8	1973			Diaph	10.5"	1-1/8" x 10
		1973			Diaph	11"	1-1/8" x 10
	7.5L (455ci) V8	1973-1974			Diaph	10.5"	1-1/8" x 10
7.5L (455ci) V8	1973-1974	With 4 Speed, 4 Barrel Carburetor		Diaph	11"	1-1/8" x 26	
GS	5.7L (350ci) V8	1971-1972			Diaph	10.5"	1-1/8" x 10
		1971-1972			Diaph	11"	1-1/8" x 10
GS 350	5.7L (350ci) V8	1968-1969			Diaph	10.5"	1-1/8" x 10
GS 400	6.6L (400ci) V8	1968-1969			Diaph	11"	1-1/8" x 10
GS 455	7.5L (455ci) V8	1970-1972			Diaph	10.5"	1-1/8" x 10
		1970-1972			Diaph	11"	1-1/8" x 10
		1970-1972	With 4 Speed, 4 Barrel Carburetor		Diaph	11"	1-1/8" x 26
GS 455 GSX	7.5L (455ci) V8	1970			Diaph	11"	1-1/8" x 10
Gran Sport	5.6L (340ci) V8	1967			Diaph	10.5"	1-1/8" x 10
	6.6L (401ci) V8	1966			Diaph	11"	1-1/8" x 10
	6.6L (400ci) V8	1967			Diaph	11"	1-1/8" x 10
CADILLAC							
CTS V	6.2L (376ci) V8	2009-2011			Diaph	12"	1-1/8" x 26
CHEVROLET							
Bel Air, Biscayne, Nomad	6 Cylinder						
	3.8L (230ci) L6	1955-1964			Diaph	10.5"	1-1/8" x 10
	4.1L (250ci) L6	1965-1973			Diaph	10.5"	1-1/8" x 10
	4.3L (261ci) L6	1955-1960			Diaph	10.5"	1-1/8" x 10
		1955-1960			Diaph	11"	1-1/8" x 10

For Footnote references, please see page 45.

PERFORMANCE STREET GUIDE

Clutch Kit Assemblies Application Guide - Cars (cont.)

Street Pro	HP	Super Street Pro	HP	RST Twin	HP	RXT Twin	HP	Street Twin	HP
75117	375	75217	500	6913-04	800	6923-04	1000	N/A	
75124	400	75224		6911-04	800	6921-04	1000	N/A	
75117	375	75217	500	6913-04	800	6923-04	1000	N/A	
75124	400	75224		6911-04	800	6921-04	1000	N/A	
75117	375	75217	500	6913-04	800	6923-04	1000	N/A	
75121	400	75221	550	6911-07	800	6921-07	1000	N/A	
75117	375	75217	500	6913-04	800	6923-04	1000	N/A	
75117	375	75217	500	6913-04	800	6923-04	1000	N/A	
75124	400	75224	550	6911-04	800	6921-04	1000	N/A	
75117	375	75217	500	6913-04	800	6923-04	1000	N/A	
75121	400	75221	550	6911-07	800	6921-07	1000	N/A	
75117	375	75217	500	6913-04	800	6923-04	1000	N/A	
75124	400	75224	550	6911-04	800	6921-04	1000	N/A	
75117	375	75217	500	6913-04	800	6923-04	1000	N/A	
75124	400	75224	550	6911-04	800	6921-04	1000	N/A	
75121	400	75221	550	6911-07	800	6921-07	1000	N/A	
75124	400	75224	550	6911-04	800	6921-04	1000	N/A	
75117	375	75217	500	6913-04	800	6923-04	1000	N/A	
75124	400	75224	550	6911-04	800	6921-04	1000	N/A	
75124	400	75224	550	6911-04	800	6921-04	1000	N/A	
N/A		N/A		6975-07	800	6975-07M	1000	640557-07	
75117	375	75217	500	6913-04	800	6923-04	1000	N/A	
75117	375	75217	500	6913-04	800	6923-04	1000	N/A	
75117	375	75217	500	6913-04	800	6923-04	1000	N/A	
75124	400	75224	550	6911-04	800	6921-04	1000	N/A	

Performance Street Guide



Did You Know?

The acronym RST & RXT stand for Red's Street Twin & Red's Extreme Twin, named after our founder Red Roberts.

PERFORMANCE STREET GUIDE

Clutch Kit Assemblies Application Guide - Cars (cont.)

Make & Model	Engine	Year	Vehicle Option	Foot Note	Type	Stock Size	Spline	
Bel Air, Biscayne, Nomad	8 Cylinder							
	4.5L (265ci) V8	1955-1956			Diaph	10.5"	1-1/8" x 10	
	4.6L (283ci) V8	1957-1967			Diaph	10.5"	1-1/8" x 10	
		1957-1967			Diaph	11"	1-1/8" x 10	
	5.0L (307ci) V8	1968			Diaph	10.5"	1-1/8" x 10	
		1968			Diaph	11"	1-1/8" x 10	
	5.3L (327ci) V8	1962-1969			Diaph	10.5"	1-1/8" x 10	
		1962-1969			Diaph	11"	1-1/8" x 10	
	5.7L (350ci) V8	1958-1961			Diaph	10.5"	1-1/8" x 10	
		1958-1961			Diaph	11"	1-1/8" x 10	
		1969-1975			Diaph	11"	1-1/8" x 10	
		1969-1973	4 Speed Muncie		Diaph	11"	1-1/8" x 26	
	6.5L (396ci) V8	1965			Diaph	10.5"	1-1/8" x 10	
		1965-1969			Diaph	11"	1-1/8" x 10	
	6.6L (400ci) V8	1970-1975			3	Diaph	11"	1-1/8" x 10
	6.6L (402ci) V8	1971-1972				Diaph	11"	1-1/8" x 10
		1970-1972	4 Speed Muncie			Diaph	11"	1-1/8" x 26
	6.7L (409ci) V8	1961-1965				Diaph	10.5"	1-1/8" x 10
1961-1965					Diaph	11"	1-1/8" x 10	
7.0L (427ci) V8	1966-1969				Diaph	10.5"	1-1/8" x 10	
	1966-1969				Diaph	11"	1-1/8" x 10	
7.4L (454ci) V8	1970-1974			3	Diaph	11"	1-1/8" x 10	
	1971-1973	4 Speed Muncie		3	Diaph	11"	1-1/8" x 26	
Camaro	6 Cylinder							
	3.8L (229ci) V6	1980			Diaph	10.5"	1-1/8" x 10	
	4.1L (250ci) L6	1967-1979				Diaph	10.5"	1-1/8" x 10
1979					Diaph	11"	1-1/8" x 10	
Camaro	8 Cylinder							
	4.6L (283ci) V8	1967			Diaph	11"	1-1/8" x 10	
	4.9L (302ci) V8	1967-1969			Diaph	11"	1-1/8" x 10	
	5.0L (305ci) V8	1977-1980				Diaph	10.5"	1-1/8" x 10
		1976-1980				Diaph	11"	1-1/8" x 10
	5.0L (307ci) V8	1971-1973			Diaph	11"	1-1/8" x 10	
	5.3L (327ci) V8	1967-1969			Diaph	11"	1-1/8" x 10	
	5.7L (350ci) V8	1969-1979				Diaph	10.5"	1-1/8" x 10
		1967-1980				Diaph	11"	1-1/8" x 10
		1971-1980				Diaph	11"	1-1/8" x 26
	6.5L (396ci) V8	1967-1971				Diaph	11"	1-1/8" x 10
	6.6L (402ci) V8	1970-1972				Diaph	11"	1-1/8" x 10
7.0L (427ci) V8	1969				Diaph	11"	1-1/8" x 10	

For Footnote references, please see page 45.

PERFORMANCE STREET GUIDE

Clutch Kit Assemblies Application Guide - Cars (cont.)

Street Pro	HP	Super Street Pro	HP	RST Twin	HP	RXT Twin	HP	Street Twin	HP
75117	375	75217	500	6913-04	800	6923-04	1000	6400104	1200
75117	375	75217	500	6913-04	800	6923-04	1000	6400104	1200
75124	400	75224	550	6911-04	800	6921-04	1000	6400104	1200
75117	375	75217	500	6913-04	800	6923-04	1000	6400104	1200
75124	400	75224	550	6911-04	800	6921-04	1000	6400104	1200
75117	375	75217	500	6913-04	800	6923-04	1000	6400104	1200
75124	400	75224	550	6911-04	800	6921-04	1000	6400104	1200
75117	375	75217	500	6913-04	800	6923-04	1000	6400104	1200
75124	400	75224	550	6911-04	800	6921-04	1000	6400104	1200
75124	400	75224	550	6911-04	800	6921-04	1000	6400104	1200
75121	400	75221	550	6911-07	800	6921-07	1000	6400107	1200
75117	375	75217	500	6913-04	800	6923-04	1000	6400307	1200
75124	400	75224	500	6911-04	800	6921-04	1000	6400104	1200
75124	400	75224	550	6911-04	800	6921-04	1000	6400104 (3)	1200
75124	400	75224	550	6911-04	800	6921-04	1000	6400104	1200
75121	400	75221	550	6911-07	800	6921-07	1000	6400107	1200
75117	375	75217	500	6913-04	800	6923-04	1000	6400104	1200
75124	400	75224	550	6911-04	800	6921-04	1000	6400104	1200
75117	375	75217	500	6913-04	800	6923-04	1000	6400307	1200
75124	400	75224	550	6911-04	800	6921-04	1000	6400104	1200
75124	400	75224	550	6911-04	800	6921-04	1000	6400104 (3)	1200
75121	400	75221	550	6911-07	800	6921-07	1000	6400107 (3)	1200
75117	375	75217	500	6913-04	800	6923-04	1000	6400104	1200
75117	375	75217	500	6913-04	800	6923-04	1000	6400104	1200
75124	400	75224	550	6911-04	800	6921-04	1000	6400104	1200
75124	400	75224	550	6911-04	800	6921-04	1000	6400104	1200
75117	375	75217	500	6913-04	800	6923-04	1000	6400104	1200
75124	400	75224	550	6911-04	800	6921-04	1000	6400104	1200
75124	400	75224	550	6911-04	800	6921-04	1000	6400104	1200
75124	400	75224	550	6911-04	800	6921-04	1000	6400104	1200
75117	375	75217	500	6913-04	800	6923-04	1000	6400104	1200
75124	400	75224	550	6911-04	800	6921-04	1000	6400104	1200
75121	400	75221	550	6911-07	800	6921-07	1000	6400107	1200
75124	400	75224	550	6911-04	800	6921-04	1000	6400104	1200
75124	400	75224	550	6911-04	800	6921-04	1000	6400104	1200
75124	400	75224	550	6911-04	800	6921-04	1000	6400104	1200

PERFORMANCE STREET GUIDE

Clutch Kit Assemblies Application Guide - Cars (cont.)

Make & Model	Engine	Year	Vehicle Option	Foot Note	Type	Stock Size	Spline
Camaro Berlinetta	6 Cylinder						
	3.8L (229ci) V6	1980-1981			Diaph	10.5"	1-1/8" x 10
	3.8L (231ci) V6	1980-1981			Diaph	10.5"	1-1/8" x 10
	4.1L (250ci) L6	1979			Diaph	10.5"	1-1/8" x 10
					Diaph	11"	1-1/8" x 10
	8 Cylinder						
	4.4L (267ci) V8	1980			Diaph	11"	1-1/8" x 10
	5.0L (305ci) V8	1979-1981			Diaph	10.5"	1-1/8" x 10
		1979-1980			Diaph	11"	1-1/8" x 10
		1981			Diaph	11"	1-1/8" x 26
		1982-1985	4 & 5 Speed		Diaph	10.5"	1-1/8" x 26
	5.7L (350ci) V8	1979			Diaph	10.5"	1-1/8" x 10
		1979-1980			Diaph	11"	1-1/8" x 10
		1979-1981	Muncie M21		Diaph	11"	1-1/8" x 26
Camaro Indianapolis 500 Pace Car	5.7L (350ci) V8	1993		3	Diaph	11"	1-1/8" x 26
Camaro Iroc-Z	5.0L (305ci) V8	1982-1985	4 & 5 Speed	3	Diaph	10.5"	1-1/8" x 26
	5.7L (350ci) V8	1986-1987	4 & 5 Speed	3	Diaph	10.5"	1-1/8" x 26
Camaro RS	6 Cylinder						
	4.1L (250ci) L6	1975			Diaph	11"	1-1/8" x 10
	8 Cylinder						
	5.0L (305ci) V8	1989-1992		3	Diaph	10.5"	1-1/8" x 26
	5.7L (350ci) V8	1975			Diaph	10.5"	1-1/8" x 10
		1975	4 Speed Muncie		Diaph	11"	1-1/8" x 26
		1975			Diaph	11"	1-1/8" x 10
	5.7L (350ci) V8	1975			Diaph	10.5"	1-1/8" x 10
		1975	4 Speed Muncie		Diaph	11"	1-1/8" x 26
		1975			Diaph	11"	1-1/8" x 10
Camaro Rally Sport	6 Cylinder						
	3.8L (229ci) V6	1980			Diaph	10.5"	1-1/8" x 10
	3.8L (231ci) V6	1980			Diaph	10.5"	1-1/8" x 10
	4.1L (250ci) L6	1976-1978			Diaph	11"	1-1/8" x 10
		1979			Diaph	10.5"	1-1/8" x 10
	8 Cylinder						
	4.4L (267ci) V8	1980			Diaph	11"	1-1/8" x 10
	5.0L (305ci) V8	1976-1980			Diaph	11"	1-1/8" x 10
		1977-1980			Diaph	10.5"	1-1/8" x 10
	5.7L (350ci) V8	1976-1979			Diaph	10.5"	1-1/8" x 10
		1976-1980	4 Speed Muncie		Diaph	11"	1-1/8" x 26
1976-1980				Diaph	11"	1-1/8" x 10	
Camaro SS	6.2L (376ci) V8	2010-2014	LS3	4	Diaph	12"	1-1/8" x 26

For Footnote references, please see page 45.

PERFORMANCE STREET GUIDE

Clutch Kit Assemblies Application Guide - Cars (cont.)

Street Pro	HP	Super Street Pro	HP	RST Twin	HP	RXT Twin	HP	Street Twin	HP
75117	375	75217	500	6913-04	800	6923-04	1000	6400104	1200
75117	375	75217	500	6913-04	800	6923-04	1000	6400104	1200
75117	375	75217	500	6913-04	800	6923-04	1000	6400104	1200
75124	400	75224	550	6911-04	800	6921-04	1000	6400104	1200
75124	400	75224	550	6911-04	800	6921-04	1000	6400104	1200
75117	375	75217	500	6913-04	800	6923-04	1000	6400104	1200
75124	400	75224	550	6911-04	800	6921-04	1000	6400104	1200
75121	400	75221	550	6911-07	800	6921-07	1000	6400107	1200
75117	375	75217	500	6913-07	800	6921-07	1000	6400307	1200
75117	375	75217	500	6913-04	800	6923-04	1000	6400104	1200
75124	400	75224	550	6911-04	800	6921-04	1000	6400104	1200
75121	400	75221	550	6911-07	800	6921-07	1000	6400107	1200
75116	400	75216	550	N/A		N/A		6402207 (3)	1200
75125	375	75225	500	6913-07	800	6923-07	1000	6400107 (3)	1200
75125	375	75225	500	6913-07	800	6923-07	1000	6400407 (3)	1200
75124	400	75224	550	6911-04	800	6921-04	1000	6400104	1200
75125	375	75225	500	6913-07	800	6923-07	1000	6400107 (3)	1200
75117	375	75217	500	6913-04	800	6923-04	1000	6400304	1200
75121	400	75221	550	6911-07	800	6921-07	1000	6400107	1200
75124	400	75224	550	6911-04	800	6921-04	1000	6400104	1200
75117	375	75217	500	6913-04	800	6923-04	1000	6400304	1200
75121	400	75221	550	6911-07	800	6921-07	1000	6400107	1200
75124	400	75224	550	6911-04	800	6921-04	1000	6400104	1200
75117	375	75217	500	6913-04	800	6923-04	1000	6400104	1200
75117	375	75217	500	6913-04	800	6923-04	1000	6400104	1200
75124	400	75224	550	6911-04	800	6921-04	1000	6400104	1200
75117	375	75217	500	6913-04	800	6923-04	1000	6400104	1200
75124	400	75224	550	6911-04	800	6921-04	1000	6400104	1200
75124	400	75224	550	6911-04	800	6921-04	1000	6400104	1200
75117	375	75217	500	6913-04	800	6923-04	1000	6400104	1200
75117	375	75217	500	6913-04	800	6923-04	1000	6400104	1200
75121	400	75221	550	6911-07	800	6921-07	1000	6400107	1200
75124	400	75224	550	6911-04	800	6921-04	1000	6400104	1200
75152		N/A		6405507	800	6405507M	1000	6404807	1200

PERFORMANCE STREET GUIDE

Clutch Kit Assemblies Application Guide - Cars (cont.)

Make & Model	Engine	Year	Vehicle Option	Foot Note	Type	Stock Size	Spline	
Camaro Z28	5.0L (305ci) V8	1986-1992	4 & 5 Speed	3	Diaph	10.5"	1-1/8" x 26	
		1981-1985	4 Speed		Diaph	11"	1-1/8" x 26	
		1977-1979			Diaph	10.5"	1-1/8" x 10	
		1977-1981	Muncie M21		Diaph	11"	1-1/8" x 26	
		1977-1980			Diaph	11"	1-1/8" x 10	
Camaro Z28 30th Anniversary Edition	5.7L (350ci) V8	1997		3	Diaph	11"	1-1/8" x 26	
Camaro Z28 Heritage Edition	5.0L (305ci) V8	1992		3	Diaph	10.5"	1-1/8" x 26	
	5.7L (350ci) V8	1992		3	Diaph	10.5"	1-1/8" x 26	
Camaro Z28 Iroc-Z	5.0L (305ci) V8	1985			Diaph	10.5"	1-1/8" x 26	
	5.0L (305ci) V8	1986-1987		3	Diaph	10.5"	1-1/8" x 26	
	5.7L (350ci) V8	1987		3	Diaph	10.5"	1-1/8" x 26	
Camaro Z28 SS	5.7L (350ci) V8	1998-2002		2	Diaph	11"	1-1/8" x 26	
Camaro ZL1	6.2L (376ci) V8	2012 -2014			Diaph	10" twin	1-1/8" x 26	
Caprice	6 Cylinder							
	4.1 (250ci) L6	1969-1979			Diaph	11"	1-1/8" x 10	
	8 Cylinder							
	4.4L (267ci) V8	1980-1982			Diaph	11"	1-1/8" x 10	
	4.6L (283ci) V8	1966-1967			Diaph	11"	1-1/8" x 10	
	5.0L (307ci) V8	1968-1973			Diaph	11"	1-1/8" x 10	
	5.3L (327ci) V8	1966-1969			Diaph	11"	1-1/8" x 10	
	5.0L (305ci) V8	1979-1985			Diaph	11"	1-1/8" x 10	
	5.7L (350ci) V8	1969-1985			Diaph	11"	1-1/8" x 10	
	6.5L (396ci) V8	1966-1969			3	Diaph	11"	1-1/8" x 10
	6.6L (400ci) V8	1970-1976			3	Diaph	11"	1-1/8" x 10
	6.6L (402ci) V8	1970-1972				Diaph	11"	1-1/8" x 10
	7.0L (427ci) V8	1966-1969				Diaph	11"	1-1/8" x 10
7.4L (454ci) V8	1970-1976			3	Diaph	11"	1-1/8" x 10	
Chevelle/Malibu	6 Cylinder							
	3.8L (229ci) V6	1979-1980			Diaph	10.5"	1-1/8" x 10	
	3.8L (231ci) V6	1978-1980			Diaph	10.5"	1-1/8" x 10	
	3.8L (230ci) L6	1964-1967			Diaph	10.5"	1-1/8" x 10	
	4.1L (250ci) L6	1964-1978			Diaph	10.5"	1-1/8" x 10	
Chevelle/Malibu	8 Cylinder							
	4.4L (267ci) V8	1979-1982			Diaph	10.5"	1-1/8" x 10	
	4.6L (283ci) V8	1964-1967	4 Speed		Diaph	10.5"	1-1/8" x 10	
	5.0L (305ci) V8	1976-1980	4 Speed		Diaph	10.5"	1-1/8" x 10	
		1981	5 Speed		Diaph	10.5"	1-1/8" x 26	
	5.0L (307ci) V8	1968-1973			Diaph	10.5"	1-1/8" x 10	
5.3L (327ci) V8	1964-1969			Diaph	10.5"	1-1/8" x 10		

For Footnote references, please see page 45.

PERFORMANCE STREET GUIDE

Clutch Kit Assemblies Application Guide - Cars (cont.)

Street Pro	HP	Super Street Pro	HP	RST Twin	HP	RXT Twin	HP	Street Twin	HP
75125	375	75225	500	6913-07	800	6923-07	1000	6400407 (3)	1200
75121	400	75221	550	6911-07	800	6921-07	1000	6400107	1200
75117	375	75217	500	6913-04	800	6923-04	1000	6400104	1200
75121	400	75221	550	6911-07	800	6921-07	1000	6400107	1200
75124	400	75224	550	6911-04	800	6921-04	1000	6400104	1200
75116	400	75216	550	N/A		N/A		6402207 (3)	1200
75125	375	75225	500	6913-07	800	6923-07	1000	6400407 (3)	1200
75125	375	75225	500	6913-07	800	6923-07	1000	6400407 (3)	1200
75125	375	75225	500	6913-07	800	6923-07	1000	6400307	1200
75125	375	75225	500	6913-07	800	6923-07	1000	6400407 (3)	1200
75125	375	75225	500	6913-07	800	6923-07	1000	6400407 (3)	1200
75123	400	75250	550	6912-07	800	6932-07	1000	64050B07	1200
N/A		N/A		N/A		6406807M	1000	64058707	1200
75124	400	75224	550	6911-04	800	6921-04	1000	6400104	1200
75124	400	75224	550	6911-04	800	6921-04	1000	6400104	1200
75124	400	75224	550	6911-04	800	6921-04	1000	6400104	1200
75124	400	75224	550	6911-04	800	6921-04	1000	6400104	1200
75124	400	75224	550	6911-04	800	6921-04	1000	6400104	1200
75124	400	75224	550	6911-04	800	6921-04	1000	6400104	1200
75124	400	75224	550	6911-04	800	6921-04	1000	6400104	1200
75124	400	75224	550	6911-04	800	6921-04	1000	6400104	1200
75124	400	75224	550	6911-04	800	6921-04	1000	6400104 (3)	1200
75124	400	75224	550	6911-04	800	6921-04	1000	6400104	1200
75124	400	75224	550	6911-04	800	6921-04	1000	6400104	1200
75124	400	75224	550	6911-04	800	6921-04	1000	6400104 (3)	1200
75117	375	75217	500	6913-04	800	6923-04	1000	6400104	1200
75117	375	75217	500	6913-04	800	6923-04	1000	6400104	1200
75117	375	75217	500	6913-04	800	6923-04	1000	6400104	1200
75117	375	75217	500	6913-04	800	6923-04	1000	6400104	1200
75117	375	75217	500	6913-04	800	6923-04	1000	6400104	1200
75117	375	75217	500	6913-04	800	6923-04	1000	6400104	1200
75117	375	75217	500	6913-04	800	6923-04	1000	6400104	1200
75125	375	75225	500	6913-07	800	6923-07	1000	6400107	1200
75117	375	75217	500	6913-04	800	6923-04	1000	6400104	1200
75117	375	75217	500	6913-04	800	6923-04	1000	6400104	1200

PERFORMANCE STREET GUIDE

Clutch Kit Assemblies Application Guide - Cars (cont.)

Make & Model	Engine	Year	Vehicle Option	Foot Note	Type	Stock Size	Spline	
Chevelle/ Malibu	5.7L (350ci) V8	1967-1968			Diaph	11"	1-1/8" x 10	
		1969-1970	With 11" Clutch		Diaph	11"	1-1/8" x 10	
		1969-1975	With 10.5" Clutch		Diaph	10.5"	1-1/8" x 10	
		1971-1972	26 Spline Disc		Diaph	11"	1-1/8" x 26	
		1973-1977	3 spd- 2 Barrel		Diaph	10.5"	1-1/8" x 10	
	6.5L (396ci) V8	1966-1970			Diaph	11"	1-1/8" x 10	
	6.6L (400ci) V8	1970			3	Diaph	11"	1-1/8" x 10
		1971	4 Speed Muncie	3	Diaph	11"	1-1/8" x 26	
	6.6L (402ci) V8	1972			Diaph	11"	1-1/8" x 10	
7.4L (454ci) V8	1970-1974	4 Speed Muncie	3	Diaph	11"	1-1/8" x 26		
Chevy II	4 Cylinder							
	2.5L (153ci) L4	1963-1967	O.E. May Be 10"		Diaph	10.5"	1-1/8" x 10	
	6 Cylinder							
	3.2L (194ci) L6	1962-1969	O.E. May Be 10"		Diaph	10.5"	1-1/8" x 10	
	3.8L (230ci) L6	1965-1969	O.E. May Be 10"		Diaph	10.5"	1-1/8" x 10	
	4.1L (250ci) L6	1962-1969	O.E. May Be 10"		Diaph	10.5"	1-1/8" x 10	
Chevy II	8 Cylinder							
	4.6L (283ci) V8	1964-1967	O.E. May Be 10"		Diaph	10.5"	1-1/8" x 10	
	5.0L (307ci) V8	1968-1969			Diaph	10.5"	1-1/8" x 10	
	5.3L (327ci) V8	1965-1968			Diaph	10.5"	1-1/8" x 10	
	7.4L (454ci) V8	1966-1970		3	Diaph	11"	1-1/8" x 10	
Corvette	4.6L (283ci) V8	1957-1961	Carb & F.I.		Diaph	10.5"	1-1/8" x 10	
	5.3L (327ci) V8	1962-1968	O.E. May Be 10"		Diaph	10.5"	1-1/8" x 10	
	5.7L (350ci) V8	1969-1971	w/10.5" & 10 Spline		Diaph	10.5"	1-1/8" x 10	
		1967-1970	w/11" & 10 Spline		Diaph	11"	1-1/8" x 10	
		1971-1975	w/10.5" & 26 Spline		Diaph	10.5"	1-1/8" x 26	
		1973-1982	w/11" & 26 Spline		Diaph	11"	1-1/8" x 26	
		1984-1985			Diaph	10.5"	1-1/8" x 26	
		1986-1988			Diaph	10.75"	1-1/8" x 26	
		1989-1992	L98 ZF 6 Speed	3	Diaph	11"	1-1/8" x 26	
		1989-1995	LT5 ZF 6 Speed		Diaph	11"	1-1/8" x 26	
		1989-1994	LT1 ZF 6 Speed	3	Diaph	11"	1-1/8" x 26	
		1989-1995	LT1 & LT4 ZF	3	Diaph	11"	1-1/8" x 26	
	1997-2004	LS1 & LS6 T56		Diaph	12"	1-1/8" x 26		
	6.0L (364ci) V8	2005-2007	LS2 T56		Diaph	12"	1-1/8" x 26	
	6.2L (376ci) V8	2008-2013	LS3 T56		Diaph	12	1-1/8" x 26	
		2008-2013	ZR1 LS9 T56		Diaph	10" twin	1-1/8" x 26	
	6.5L (396ci) V8	1965	Big Block		Diaph	10.5"	1-1/8" x 10	
	7.0L (427ci) V8	1966-1969	Big Block		Diaph	10.5"	1-1/8" x 10	
		1966-1969	Big Block	3	Diaph	11"	1-1/8" x 10	
		2006-2013	Z06 LS7		Diaph	12"	1-1/8" x 26	
7.4L (454ci) V8	1970-1974		3	Diaph	11"	1-1/8" x 10		

For Footnote references, please see page 45.

PERFORMANCE STREET GUIDE

Clutch Kit Assemblies Application Guide - Cars (cont.)

Street Pro	HP	Super Street Pro	HP	RST Twin	HP	RXT Twin	HP	Street Twin	HP
75124	400	75224	550	6911-04	800	6921-04	1000	6400104	1200
75124	400	75224	550	6911-04	800	6921-04	1000	6400104	1200
75117	375	75217	500	6913-04	800	6923-04	1000	6400104	1200
75121	400	75221	550	6911-07	800	6921-07	1000	6400107	1200
75117	375	75217	500	6913-04	800	6923-04	1000	6400104	1200
75124	400	75224	550	6911-04	800	6921-04	1000	6400104	1200
75124	400	75224	550	6911-04	800	6921-04	1000	6400104 (3)	1200
75121	400	75221	550	6911-07	800	6921-07	1000	6400107 (3)	1200
75124	400	75224	550	6911-04	800	6921-04	1000	6400104	1200
75121	400	75221	550	6911-07	800	6921-07	1000	6400107 (3)	1200
75117	375	75217	500	6913-04	800	6923-04	1000	6400304	1200
75117	375	75217	500	6913-04	800	6923-04	1000	6400304	1200
75117	375	75217	500	6913-04	800	6923-04	1000	6400304	1200
75117	375	75217	500	6913-04	800	6923-04	1000	6400304	1200
75117	375	75217	500	6913-04	800	6923-04	1000	6400304	1200
75117	375	75217	500	6913-04	800	6923-04	1000	6400304	1200
75117	375	75217	500	6913-04	800	6923-04	1000	6400304	1200
75124	400	75224	550	6911-04	800	6921-04	1000	6400104 (3)	1200
75117	375	75217	500	6913-04	800	6923-04	1000	6400104	1200
75117	375	75217	500	6913-04	800	6923-04	1000	6400304	1200
75117	375	75217	500	6913-04	800	6923-04	1000	6400304	1200
75124	400	75224	550	6911-04	800	6921-04	1000	6400104	1200
75125	375	75225	500	6913-07	800	6923-07	1000	6400107	1200
75121	400	75221	550	6911-07	800	6923-07	1000	6400107	1200
75125	375	75225	500	6913-07	800	6923-07	1000	6400107	1200
75125	375	75225	500	6913-07	800	6923-07	1000	6400407	1200
75118	400	75218	550	N/A		N/A		6402307 (3)	1200
75118	400	75218	550	N/A		N/A		6402407	1200
75118	400	75218	550	N/A		N/A		6402307 (3)	1200
75118	400	75218	550	N/A		N/A		6402307 (3)	1200
75123	425	75223	600	6912-07	800	6932-07	1000	64047B07	1200
75152	425	75223	600	6912-07	800	6932-07	1000	64048B07	1200
75152	425	N/A		6405507	800	6405507M	1000	N/A	
N/A		N/A		6976-07	800	6976-07M	1000	N/A	
75117	375	75217	500	6913-04	800	6923-04	1000	6400104	1200
75117	375	75217	500	6913-04	800	6923-04	1000	6400104	1200
75124	400	75224	550	6911-04	800	6921-04	1000	6400104	1200
75152	425	N/A		6405507	800	6405507M	1000	6404807	1200
75124	400	75224	550	6911-04	800	6921-04	1000	6400104 (3)	1200

PERFORMANCE STREET GUIDE

Clutch Kit Assemblies Application Guide - Cars (cont.)

Make & Model	Engine	Year	Vehicle Option	Foot Note	Type	Stock Size	Spline	
El Camino	6 Cylinder							
	3.2L (194ci) L6	1963-1969	O.E. May Be 10"		Diaph	10.5"	1-1/8" x 10	
	3.3L (200ci) V6	1978-1979	O.E. May Be 10"		Diaph	10.5"	1-1/8" x 10	
	3.8L (229ci) V6	1980-1981			Diaph	10.5"	1-1/8" x 10	
	3.8L (230ci) L6	1963-1969	O.E. May Be 10"		Diaph	10.5"	1-1/8" x 10	
	3.8L (231ci) V6	1978-1980			Diaph	10.5"	1-1/8" x 10	
	3.8L (235ci) L6	1959-1962			Diaph	10.5"	1-1/8" x 10	
	4.1L (250ci) L6	1967-1977			Diaph	10.5"	1-1/8" x 10	
El Camino	8 Cylinder							
	4.4L (267ci) V8	1979-1982			Diaph	10.5"	1-1/8" x 10	
	4.6L (283ci) V8	1964-1967			Diaph	10.5"	1-1/8" x 10	
	5.0L (305ci) V8	1976-1981			Diaph	10.5"	1-1/8" x 10	
	5.0L (307ci) V8	1968-1973	3 & 4 Speed		Diaph	10.5"	1-1/8" x 10	
	5.3L (327ci) V8	1962-1968			Diaph	10.5"	1-1/8" x 10	
	5.7L (350ci) V8	1972-1975	3 Speed		Diaph	10.5"	1-1/8" x 10	
		1972-1975	4 Speed		Diaph	11"	1-1/8" x 10	
		1978-1979			Diaph	10.5"	1-1/8" x 10	
	6.5L (396ci) V8	1966-1969			Diaph	11"	1-1/8" x 10	
7.4L (454ci) V8	1970-1975	4 Speed	3	Diaph	11"	1-1/8" x 10		
Monte Carlo	6 Cylinder							
	3.3L (200ci) V6	1979			Diaph	10.5"	1-1/8" x 10	
	3.8L (229ci) V6	1980-1981			Diaph	10.5"	1-1/8" x 10	
		1978-1981			Diaph	10.5"	1-1/8" x 10	
	3.8L (231ci) V6	1980-1981	Turbo		Diaph	10.5"	1-1/8" x 10	
	8 Cylinder							
	4.4L (267ci) V8	1979-1980			Diaph	10.5"	1-1/8" x 10	
	5.0L (305ci) V8	1979-1981			Diaph	10.5"	1-1/8" x 10	
	5.7L (350ci) V8	1970-1977	10.5"		Diaph	10.5"	1-1/8" x 10	
		1971	4 Speed		Diaph	11"	1-1/8" x 26	
		1976-1977	3 Speed		Diaph	10.5"	1-1/8" x 10	
	6.6L (400ci) V8	1970			3	Diaph	11"	1-1/8" x 10
		1971			3	Diaph	11"	1-1/8" x 26
6.6L (402ci) V8	1972			Diaph	11"	1-1/8" x 26		
7.4L (454ci) V8	1970-1975			3	Diaph	11"	1-1/8" x 26	
Nova	6 Cylinder							
	4.1L (250ci) L6	1967-1979	O.E. May Be 10"		Diaph	10.5"	1-1/8" x 10	
	4.6L (283ci) V8	1966-1967			Diaph	10.5"	1-1/8" x 10	

For Footnote references, please see page 45.

PERFORMANCE STREET GUIDE

Clutch Kit Assemblies Application Guide - Cars (cont.)

Street Pro	HP	Super Street Pro	HP	RST Twin	HP	RXT Twin	HP	Street Twin	HP
75117	375	75217	500	6913-04	800	6923-04	1000	6400104	1200
75117	375	75217	500	6913-04	800	6923-04	1000	6400104	1200
75117	375	75217	500	6913-04	800	6923-04	1000	6400104	1200
75117	375	75217	500	6913-04	800	6923-04	1000	6400104	1200
75117	375	75217	500	6913-04	800	6923-04	1000	6400104	1200
75117	375	75217	500	6913-04	800	6923-04	1000	6400104	1200
75117	375	75217	500	6913-04	800	6923-04	1000	6400104	1200
75117	375	75217	500	6913-04	800	6923-04	1000	6400304	1200
75117	375	75217	500	6913-04	800	6923-04	1000	6400304	1200
75117	375	75217	500	6913-04	800	6923-04	1000	6400304	1200
75117	375	75217	500	6913-04	800	6923-04	1000	6400304	1200
75117	375	75217	500	6913-04	800	6923-04	1000	6400304	1200
75124	400	75224	550	6911-04	800	6921-04	1000	6400104	1200
75117	375	75217	500	6913-04	800	6923-04	1000	6400304	1200
75124	400	75224	550	6911-04	800	6921-04	1000	6400104	1200
75124	400	75224	550	6911-04	800	6921-04	1000	6400104 (3)	1200
75117	375	75217	500	6913-04	800	6923-04	1000	6400304	1200
75117	375	75217	500	6913-04	800	6923-04	1000	6400304	1200
75117	375	75217	500	6913-04	800	6923-04	1000	6400304	1200
75117	375	75217	500	6913-04	800	6923-04	1000	6400304	1200
75117	375	75217	500	6913-04	800	6923-04	1000	6400304	1200
75117	375	75217	500	6913-04	800	6923-04	1000	6400304	1200
75117	375	75217	500	6913-04	800	6923-04	1000	6400304	1200
75121	400	75221	550	6913-07	800	6923-07	1000	6400107	1200
75117	375	75217	500	6913-04	800	6923-04	1000	6400304	1200
75124	400	75224	550	6911-04	800	6921-04	1000	6400104 (3)	1200
75121	400	75221	550	6911-07	800	6921-07	1000	6400107 (3)	1200
75121	400	75221	550	6911-07	800	6921-07	1000	6400107	1200
75121	400	75221	550	6911-07	800	6921-07	1000	6400107 (3)	1200
75117	375	75217	500	6913-04	800	6923-04	1000	6400304	1200
75117	375	75217	500	6913-04	800	6923-04	1000	6400304	1200

Performance Street Guide

PERFORMANCE STREET GUIDE

Clutch Kit Assemblies Application Guide - Cars (cont.)

Make & Model	Engine	Year	Vehicle Option	Foot Note	Type	Stock Size	Spline	
Nova	8 Cylinder							
	5.0L (305ci) V8	1978-1979			Diaph	10.5"	1-1/8" x 10	
	5.0L (307ci) V8	1968-1973			Diaph	10.5"	1-1/8" x 10	
	5.3L (327ci) V8	1964-1969			Diaph	10.5"	1-1/8" x 10	
	5.7L (350ci) V8	1969-1979	3 Speed		Diaph	10.5"	1-1/8" x 10	
	5.7L (350ci) V8	1967-1970			Diaph	11"	1-1/8" x 10	
		1971			Diaph	11"	1-1/8" x 26	
7.4L (454ci) V8	1970-1971		3	Diaph	11"	1-1/8" x 26		
CHRYSLER								
Newport, New Yorker, Saratoga, Windsor, 300 Series	5.9L (360ci) V8	1971			Diaph	10.5"	1" x 23	
	5.4L (331ci) V8	1959-1967			Diaph	10.5"	1" x 23	
	6.3L (383ci) V8	1959-1967			Diaph	10.5"	1" x 23	
		1968-1969			Diaph	11"	1" x 23	
		1970-1971		13	Diaph	11"	1" x 23	
6.8L (413ci) V8	1959-1967			Diaph	10.5"	1" x 23		
DODGE								
Aspen, Coronet, Demon, Diplomat, GTS, Lancer (RWD), Polara, Royal, Super Bee, Swinger	4.5L (273ci) V8	1961-1969			Diaph	10.5"	1" x 23	
	5.2L (318ci) V8	1961-1979			Diaph	10.5"	1" x 23	
	5.4L (331ci) V8	1964			Diaph	10.5"	1" x 23	
	5.6L (340ci) V8	1968-1974			Diaph	10.5"	1" x 23	
	5.9L (360ci) V8	1961-1977	3 Speed	13	Diaph	10.5"	1" x 23	
	6.3L (383ci) V8	1963-1974	3 Speed	13	Diaph	10.5"	1" x 23	
	6.6L (400ci) V8	1971-1974		13	Diaph	10.5"	1" x 23	
Challenger	5.2L (318ci) V8	1970-1974			Diaph	10.5"	1" x 23	
	5.6L (340ci) V8	1970-1974			Diaph	10.5"	1" x 23	
	5.7L (348ci) V8	2009-2010			Diaph	10" twin	1-1/8" x 26	
	5.9L (360ci) V8	1973-1974	3 Speed	13	Diaph	10.5"	1" x 23	
	6.1L (372) V8	2009-2010			Diaph	10" twin	1-1/8" x 26	
	6.1L (372) V8	2011-2012			Diaph	10" twin	1-1/8" x 10	
	6.3L (383ci) V8	1970-1972	3 Speed	13	Diaph	10.5"	1" x 23	
	7.0L (426ci) V8	1970-1972	Hemi		B&B	10.95"	1-3/16" x 18	
		1967-1969			B&B	11"	1-3/16" x 18	
7.2L (440ci) V8	1970-1972			B&B	10.95"	1-3/16" x 18		
Charger	5.2L (318ci) V8	1966-1978			Diaph	10.5"	1" x 23	
	5.6L (340ci) V8	1970-1973			Diaph	10.5"	1" x 23	
	5.9L (360ci) V8	1974-1977		13	Diaph	10.5"	1" x 23	
	6.3L (383ci) V8	1967-1969			13	Diaph	10.5"	1" x 23
		1970-1971			13	Diaph	10.5"	1" x 23
	6.6L (400ci) V8	1972-1978		13	Diaph	10.5"	1" x 23	
	7.0L (426ci) V8	1970-1972	Hemi		B&B	10.95"	1-3/16" x 18	
Charger	7.2L (440ci) V8	1970-1972			B&B	10.95"	1-3/16" x 18	
		1967-1972			B&B	11"	1-3/16" x 18	

For Footnote references, please see page 45.

PERFORMANCE STREET GUIDE

Clutch Kit Assemblies Application Guide - Cars (cont.)

Street Pro	HP	Super Street Pro	HP	RST Twin	HP	RXT Twin	HP	Street Twin	HP
75117	375	75217	500	6913-04	800	6923-04	1000	6400304	1200
75117	375	75217	500	6913-04	800	6923-04	1000	6400304	1200
75117	375	75217	500	6913-04	800	6923-04	1000	6400304	1200
75117	375	75217	500	6913-04	800	6923-04	1000	6400304	1200
75124	400	75224	550	6911-04	800	6921-04	1000	6400104	1200
75121	400	75221	550	6911-07	800	6921-07	1000	6400107	1200
75121	400	75221	550	6911-07	800	6921-07	1000	6400107 (3)	1200
75109	375	75209	500	6913-02	800	6923-02	1000	6440602	1200
75109	375	75209	500	6913-02	800	6923-02	1000	N/A	
75109	375	75209	500	6913-02	800	6923-02	1000	6440602	1200
75108	400	75208	550	6911-02	800	6921-02	1000	6440602	1200
75108	400	75208	550	6911-02	800	6921-02	1000	6440602 (13)	1200
75109	375	75209	500	6913-02	800	6923-02	1000		
75109	375	75209	500	6913-02	800	6923-02	1000	N/A	
75109	375	75209	500	6913-02	800	6923-02	1000	6440602	1200
75109	375	75209	500	6913-02	800	6923-02	1000	6440602 (13)	1200
75109	375	75209	500	6913-02	800	6923-02	1000	6440602 (13)	1200
75109	375	75209	500	6913-02	800	6923-02	1000	6440602 (13)	1200
75109	375	75209	500	6913-02	800	6923-02	1000	6440602	1200
75109	375	75209	500	6913-02	800	6923-02	1000	6440602	1200
N/A		N/A		6975-07	800	6925-07	1000	N/A	
75109	375	75209	500	6913-02	800	6923-02	1000	6440602 (13)	1200
N/A		N/A		6975-07	800	6975-07M	1000	N/A	
N/A		N/A		6975-04	800	6975-04M	1000	N/A	
75109	375	75209	500	6913-02	800	6923-02	1000	6440602 (13)	1200
75139	400	75239	550	6913-05	800	6923-05	1000	6440805	1200
75140	400	75240	550	6911-05	800	6921-05	1000	6442605	1200
75139	400	75239	550	6913-05	800	6923-05	1000	6440605	1200
75109	375	75209	500	6913-02	800	6923-02	1000	6440602	1200
75109	375	75209	500	6913-02	800	6923-02	1000	6440602	1200
75109	400	75209	550	6913-02	800	6923-02	1000	6440602 (13)	1200
75109	400	75209	550	6913-02	800	6923-02	1000	6440602 (13)	1200
N/A		75209	550	6913-02	800	6923-02	1000	6440602 (13)	1200
N/A		75209	550	6913-02	800	6923-02	1000	6440602 (13)	1200
75139	400	75239	550	6913-05	800	6923-05	1000	6440805	1200
75139	400	75239	550	6913-05	800	6923-05	1000	6440605	1200
75140	400	75240	550	6911-05	800	6921-05	1000	6442605	1200

PERFORMANCE STREET GUIDE

Clutch Kit Assemblies Application Guide - Cars (cont.)

Make & Model	Engine	Year	Vehicle Option	Foot Note	Type	Stock Size	Spline	
Viper	10 Cylinder							
	8.0L (488ci) V10	1992-2002			Diaph	12"	1-1/8" x 26	
	8.0L (488ci) V10	2003-2004			Diaph	12 1/8"	1-1/8" x 26	
	8.3L (505ci) V10	2005-2007			Diaph	12 1/8"	1-1/8" x 26	
	8.3L (505ci) V10	2008-2012			Diaph	9 11/16" Twin	1-1/8" x 26	
FORD								
Cobra Jet	5.8L (351ci) V8	1972-1974			Long	11"	1 1/16" x 10	
					Diaph	11"	1-1/16" x 10	
	7.0L (428ci) V8	1969-1970		4	Diaph	12"	1-3/8" x 10	
	7.0L (429ci) V8	1969-1973		4	Diaph	12"	1-3/8" x 10	
Custom, 300, 500 Series	6 Cylinder							
	3.6L (223ci) 6L	1963-1964			Diaph	10"	1-1/16" x 10	
		1963-1964			Long	11"	1-1/16" x 10	
		1963-1964			Diaph	11"	1-1/16" x 10	
	3.9L (240ci) 6L	1965-1972			Diaph	10"	1-1/16" x 10	
		1965-1972			Long	11"	1-1/16" x 10	
1965-1972				Diaph	11"	1-1/16" x 10		
Custom, 300, 500 Series	8 Cylinder							
	4.3L (260ci) V8	1963-1967			Diaph	10"	1-1/16" x 10	
	4.7L (289ci) V8	1963-1967			Diaph	10"	1-1/16" x 10	
	5.0L (302ci) V8	1968-1972			Diaph	10"	1-1/16" x 10	
	5.8L (351ci) V8	1969-1973			Diaph	10"	1-1/16" x 10	
		1969-1973			Long	11"	1-1/16" x 10	
		1969-1973			Diaph	11"	1-1/16" x 10	
	6.4L (390ci) V8	1963-1971	3 & 4 Speed			Long	11"	1-1/16" x 10
		1963-1971	3 & 4 Speed			Diaph	11"	1-1/16" x 10
6.6L (406ci) V8	1962-1963				Long	11"	1-1/16" x 10	
					Diaph	11"	1-1/16" x 10	
Fairlane	6 Cylinder							
	4.1L (250ci) 6L	1969-1974			Diaph	10"	1-1/16" x 10	
	8 Cylinder							
	3.6L (221ci) V8	1963-1964				Diaph	10"	1-1/16" x 10
		1963-1964				Long	10.5"	1-1/16" x 10
	4.3L (260ci) V8	1963-1965				Long	10.5"	1-1/16" x 10
		1963-1965				Diaph	10"	1-1/16" x 10
	4.7L (289ci) V8	1963-1967				Long	10.5"	1-1/16" x 10
						Diaph	10"	1-1/16" x 10
	5.0L (302ci) V8	1968-1974				Diaph	10"	1-1/16" x 10
		1968-1974				Long	10.5"	1-1/16" x 10
	5.8L (351ci) V8	1968-1973				Long	11"	1-1/16" x 10
		1968-1973				Diaph	11"	1-1/16" x 10

For Footnote references, please see page 45.

PERFORMANCE STREET GUIDE

Clutch Kit Assemblies Application Guide - Cars (cont.)

Street Pro	HP	Super Street Pro	HP	RST Twin	HP	RXT Twin	HP	Street Twin	HP
N/A		N/A		69436-07		69436-07M		64436B07M	1200
N/A		N/A		69437CT-07		69437CT-07M		64437BCT07	1200
N/A		N/A		69437-07		69437-07M		64437B07M	1200
N/A		N/A		6975-07		6975-07M	1000	N/A	
75111	400	75211	550	6911-03	800	6921-03	1000	64302B03	1200
75112	400	75212	550	6911-03	800	6921-03	1000	6430203	1200
75135	425	75235	600	N/A		N/A		64304B06	1200
75135	425	75235	600	N/A		N/A		64305B06	1200
75113	375	75213	500	6913-03	800	6923-03	1000	N/A	
75111	400	75211	550	6911-03	800	6921-03	1000	N/A	
75112	400	75212	550	6911-03	800	6921-03	1000	N/A	
75113	375	75213	500	6913-03	800	6923-03	1000	N/A	
75111	400	75211	550	6911-03	800	6921-03	1000	N/A	
75112	400	75212	550	6911-03	800	6921-03	1000	N/A	
75113	375	75213	500	6913-03	800	6923-03	1000	6430103	1200
75113	375	75213	500	6913-03	800	6923-03	1000	6430103	1200
75113	375	75213	500	6913-03	800	6923-03	1000	6430103	1200
75113	375	75213	500	6913-03	800	6923-03	1000	6430203	1200
75111	400	75211	550	6911-03	800	6921-03	1000	6430203	1200
75112	400	75212	550	6911-03	800	6921-03	1000	6430203	1200
75111	400	75211	550	6911-03	800	6921-03	1000	6430403	1200
75112	400	75212	550	6911-03	800	6921-03	1000	6430403	1200
75111	400	75211	550	6911-03	800	6921-03	1000	6430403	1200
75112	400	75212	550	6911-03	800	6921-03	1000	6430403	1200
75113	375	75213	500	6913-03	800	6923-03	1000	N/A	
75113	375	75213	500	6913-03	800	6923-03	1000	6430103	1200
75133	375	75233	500	6913-03	800	6923-03	1000	6430103	1200
75133	375	75233	500	6913-03	800	6923-03	1000	6430203	1200
75133	375	75233	500	6913-03	800	6923-03	1000	6430203	1200
75113	375	75213	500	6913-03	800	6923-03	1000	6430203	1200
75113	375	75233	500	6913-03	800	6923-03	1000	6430203	1200
75113	375	75213	500	6913-03	800	6923-03	1000	6430203	1200
75113	375	75213	500	6913-03	800	6923-03	1000	6430203	1200
75133	375	75233	500	6913-03	800	6923-03	1000	6430203	1200
75111	400	75211	550	6911-03	800	6921-03	1000	6430203	1200
75112	400	75212	550	6911-03	800	6921-03	1000	6430203	1200

PERFORMANCE STREET GUIDE

Clutch Kit Assemblies Application Guide - Cars (cont.)

Make & Model	Engine	Year	Vehicle Option	Foot Note	Type	Stock Size	Spline	
Fairlane	6.4L (390ci) V8	1963-1971			Long	11"	1-1/16" x 10	
		1963-1971			Diaph	11"	1-1/16" x 10	
		1963-1969	Fe Big Block		Long	11"	1-1/16" x 10	
		1963-1969	Fe Big Block		Diaph	11"	1-1/16" x 10	
		1963-1969	GT Fe Big Block	4, 19	Diaph	12"	1-3/8" x 10	
	7.0L (428ci) V8	1969	Fe Big Block	4, 19	Diaph	12"	1-3/8" x 10	
	7.0L (429ci) V8	1970		4, 19	Diaph	12"	1-3/8" x 10	
Falcon	4.3L (260ci) V8	1963-1965			Diaph	10"	1-1/16" x 10	
	4.7L (289ci) V8	1965-1968			Diaph	10"	1-1/16" x 10	
		1965-1968			Long	10.5"	1-1/16" x 10	
	5.0L (302ci) V8	1968-1970			Diaph	10"	1-1/16" x 10	
		1968-1970			Long	10.5"	1-1/16" x 10	
	5.8L (351ci) V8	1968-1970			Long	11"	1-1/16" x 10	
		1968-1970			Diaph	11"	1-1/16" x 10	
Galaxie	6 Cylinder							
	3.6L (223ci) 6L	1963-1964			Diaph	10"	1-1/16" x 10	
		1963-1964			Long	11"	1-1/16" x 10	
		1963-1964			Diaph	11"	1-1/16" x 10	
	3.9L (240ci) 6L	1965-1972			Diaph	10"	1-1/16" x 10	
		1965-1972			Long	11"	1-1/16" x 10	
		1965-1972			Diaph	11"	1-1/16" x 10	
	8 Cylinder							
	4.3L (260ci) V8	1963-1965	Late 1963			Long	10.5"	1-1/16" x 10
		1963-1965	Late 1963			Diaph	10"	1-1/16" x 10
	4.7L (289ci) V8	1963-1968				Long	10.5"	1-1/16" x 10
		1963-1968				Diaph	10"	1-1/16" x 10
	5.0L (302ci) V8	1968-1971				Diaph	10"	1-1/16" x 10
		1968-1971				Long	10.5"	1-1/16" x 10
	5.8L (351ci) V8	1968-1973				Long	11"	1-1/16" x 10
		1968-1973				Diaph	11"	1-1/16" x 10
	5.8L (352ci) V8	1964-1965	Fe Big Block			Long	11"	1-1/16" x 10
		1964-1965	Fe Big Block			Diaph	11"	1-1/16" x 10
	6.4L (390ci) V8	1964-1970	Fe Big Block			Long	11"	1-1/16" x 10
		1964-1970	Fe Big Block			Diaph	11"	1-1/16" x 10
1964-1967		GT Fe Big Block	4, 19		Diaph	12"	1-1/16" x 10	
6.4L (406ci) V8	1963				Long	11"	1-1/16" x 10	
	1963	4 Speed			Diaph	11"	1-1/16" x 10	
7.0L (427ci) V8	1963-1964	Fe Big Block	4, 19		Diaph	12"	1-1/16" x 10	
	1965-1970	Fe Big Block	4, 19		Diaph	12"	1-3/8" x 10	
7.0L (428ci) V8	1966-1970	Fe Big Block	4, 19		Diaph	12"	1-3/8" x 10	
7.0L (429ci) V8	1969-1972		4, 19		Diaph	12"	1-3/8" x 10	

For Footnote references, please see page 45.

PERFORMANCE STREET GUIDE

Clutch Kit Assemblies Application Guide - Cars (cont.)

Street Pro	HP	Super Street Pro	HP	RST Twin	HP	RXT Twin	HP	Street Twin	HP
75111	400	75211	550	6911-03	800	6921-03	1000	6430403	1200
75112	400	75212	550	6911-03	800	6921-03	1000	6430403	1200
75111	400	75211	550	6911-03	800	6921-03	1000	6430403	1200
75112	400	75212	550	6911-03	800	6921-03	1000	6430403	1200
75135	425	75235	600	6911-03	800	6921-03	1000	64304B06	1200
75135	425	75235	600	6911-06	800	6921-06	1000	64304B06	1200
75135	425	75235	600	6911-06	800	6921-06	1000	64305B06	1200
75113	375	75213	500	6913-03	800	6923-03	1000	6430103	1200
75113	375	75213	500	6913-03	800	6923-03	1000	6430103	1200
75133	375	75233	500	6913-03	800	6923-03	1000	6430103	1200
75113	375	75213	500	6913-03	800	6923-03	1000	6430203	1200
75133	375	75233	500	6913-03	800	6923-03	1000	6430203	1200
75111	400	75211	550	6911-03	800	6921-03	1000	6430203	1200
75112	400	75212	550	6911-03	800	6921-03	1000	6430203	1200
75113	375	75213	500	6913-03	800	6923-03	1000	N/A	
75111	400	75211	550	6911-03	800	6921-03	1000	N/A	
75112	400	75212	550	6911-03	800	6921-03	1000	N/A	
75113	375	75213	500	6913-03	800	6923-03	1000	N/A	
75111	400	75211	550	6911-03	800	6921-03	1000	N/A	
75112	400	75212	550	6911-03	800	6921-03	1000	N/A	
75133	375	75233	500	6913-03	800	6923-03	1000	6430103	1200
75113	375	75213	500	6913-03	800	6923-03	1000	6430103	1200
75133	375	75233	500	6913-03	800	6923-03	1000	6430203	1200
75113	375	75213	500	6913-03	800	6923-03	1000	6430203	1200
75113	375	75213	500	6913-03	800	6923-03	1000	6430203	1200
75133	375	75233	500	6913-03	800	6923-03	1000	6430203	1200
75111	400	75211	550	6911-03	800	6923-03	1000	6430203	1200
75112	400	75212	550	6911-03	800	6921-03	1000	6430203	1200
75111	400	75211	550	6911-03	800	6923-03	1000	6430403	1200
75112	400	75212	550	6911-03	800	6921-03	1000	6430403	1200
75111	400	75211	550	6911-03	800	6923-03	1000	6430403	1200
75112	400	75212	550	6911-03	800	6921-03	1000	6430403	1200
75134	425	75234	600	6911-03	800	6921-03	1000	6430403	1200
75111	400	75211	550	6911-03	800	6923-03	1000	6430403	1200
75112	400	75212	550	6911-03	800	6921-03	1000	6430403	1200
75134	425	75234	600	6911-03	800	6921-03	1000	6430403	1200
75135	425	75235	600	6911-06	800	6921-06	1000	64304B06	1200
75135	425	75235	600	6911-06	800	6921-06	1000	64304B06	1200
75135	425	75235	600	6911-06	800	6921-06	1000	64305B06	1200

PERFORMANCE STREET GUIDE

Clutch Kit Assemblies Application Guide - Cars (cont.)

Make & Model	Engine	Year	Vehicle Option	Foot Note	Type	Stock Size	Spline	
Mustang, Mustang II	6 Cylinder							
	4.1L (250ci) 6L	1969-1973			Diaph	10"	1-1/16" x 10	
	8 Cylinder							
	4.6L (281ci) V8	1996-1998	6 Bolt Crank GT With T45			Diaph	10.5"	1-1/16" x 10
		1996-1998	6 Bolt Crank GT With T45 - With Aftermarket 26 Spline Trans			Diaph	10.5"	1 1/8" x 26
		1996-1998	8 Bolt Crank GT With T45			Diaph	10.5"	1-1/16" x 10
		1996-1998	8 Bolt Crank GT With T45 - With Aftermarket 26 Spline Trans			Diaph	10.5"	1-1/8" x 26
		1999-2004	6 Bolt Crank			Diaph	11"	1-1/16" x 10
		1999-2004	8 Bolt Crank With Aftermarket 26 Spline Trans			Diaph	11"	1-1/8" x 26
	4.7L (289ci) V8	1964-1969				Long	10.5"	1-1/16" x 10
		1964-1969				Diaph	10"	1-1/16" x 10
	5.0L (302ci) V8	1968-1974	4 Speed Mech Linkage			Long	10.5"	1-1/16" x 10
		1968-1974	4 Speed Mech Linkage			Diaph	10"	1-1/16" x 10
		1979-1985	T-5			Diaph	10"	1-1/16" x 10
		1986-1995	T-5			Diaph	10.5"	1-1/16" x 10
	5.0L V8 Coyote	2011-2014	GT	18, 20		Diaph	11"	1" x23
	5.8L (351ci) V8	1968-1974				Long	11"	1-1/16" x 10
		1968-1974				Diaph	11"	1-1/16" x 10
	5.4L (330ci) V8	2005-2010				Diaph	11"	1-1/16" x 10
		2005-2010	With Aftermarket 26 Spline Trans			Diaph	11"	1-1/8" x 26
		2007-2009	Shelby GT500	6, 7		Diaph	8.5" twin	1-1/8" x 26
		2010-2012	Shelby GT500	6, 7		Diaph	9" twin	1-1/8" x 26
	5.8L (302ci) V8	2013-2014	Shelby GT500	6, 7		Diaph	10" twin	1-1/8" x 26
	6.4L (390ci) V8	1969-1974	Fe Big Block			Long	11"	1-1/16" x 10
		1969-1974	Fe Big Block			Diaph	11"	1-1/16" x 10
	7.0L (428ci) V8	1967-1968	Shelby GT 500	4		Diaph	12"	1-3/8" x 10
Ranchero	5.0L (302ci) V8	1968-1974	4 Speed Mech Linkage			Long	11"	1-1/16" x 10
		1968-1974	4 Speed Mech Linkage			Diaph	11"	1-1/16" x 10
	5.8L (351ci) V8	1970-1974				Long	11"	1-1/16" x 10
		1970-1974				Diaph	11"	1-1/16" x 10
	6.4L (390ci) V8	1967-1969	Fe Big Block			Long	11"	1-1/16" x 10
		1967-1969	Fe Big Block			Diaph	11"	1-1/16" x 10
	7.0L (429ci) V8	1970-1973		4, 19		Diaph	12"	1-3/8" x 10

For Footnote references, please see page 45.

PERFORMANCE STREET GUIDE

Clutch Kit Assemblies Application Guide - Cars (cont.)

Street Pro	HP	Super Street Pro	HP	RST Twin	HP	RXT Twin	HP	Street Twin	HP
75113	375	75213	500	6913-03	800	6923-03	1000	N/A	
75105	375	75205	500	6913-03	800	6923-03	1000	6430603	1200
75107	375	75207	500	6913-07	800	6923-07	1000	6430607	1200
75105	375	75205	500	6913-03	800	6923-03	1000	6430803	1200
75107	375	75207	500	6913-07	800	6923-07	1000	6430807	1200
75104	400	75204	550	6912-03	800	6932-03	1000	6430603	1200
75103		75203	550	6912-07	800	6932-07	1000	6430803	1200
75133	375	75233	500	6913-03	800	6923-03	1000	6430103	1200
75113	375	75213	500	6913-03	800	6923-03	1000	6430103	1200
N/A		75233	500	6913-03	800	6923-03	1000	6430103	1200
75113	375	75213	500	6913-03	800	6923-03	1000	6430203	1200
75115	375	75215	500	6913-03	800	6923-03	1000	6430103	1200
75105	375	75205	500	6913-03	800	6923-03	1000	6430103	1200
75153	400	75253	500			6932-25	1000	6430825	1200
75111	400	75211	550	6911-03	800	6921-03	1000	64302B03	1200
75112	400	75212	550	6911-03	800	6921-03	1000	6430203	1200
75101	400	75201	550	6912-03	800	6932-03	1000	6430803	1200
75103	400	75203	550	6912-07	800	6932-07	1000	6430803	1200
N/A		N/A		6908-07	800	6918-07	1000	6431807	1200
N/A		N/A				6975-07M	1000	6431807 (22)	1200
N/A		N/A				6975-07M	1000	6431807 (22)	1200
75111	400	75211	550	6911-03	800	6921-03	1000	64304B03	1200
75112	400	75212	550	6911-03	800	6921-03	1000	64304B03	1200
75135	425	75235	600	N/A		N/A		64304B06	1200
75111	400	75211	550	6911-03	800	6921-03	1000	6430203	1200
75112	400	75212	550	6911-03	800	6921-03	1000	6430203	1200
75111	400	75211	550	6911-03	800	6921-03	1000	6430203	1200
75112	400	75212	550	6911-03	800	6921-03	1000	6430203	1200
75111	400	75211	550	6911-03	800	6921-03	1000	6430403	1200
75212	400	75212	550	6911-03	800	6921-03	1000	6430403	1200
75135	425	75235	600	6911-06	800	6921-06	1000	64305B06	1200

PERFORMANCE STREET GUIDE

Clutch Kit Assemblies Application Guide - Cars (cont.)

Make & Model	Engine	Year	Vehicle Option	Foot Note	Type	Stock Size	Spline
Torino	5.0L (302ci) V8	1969-1973			Diaph	10"	1-1/16" x 10
		1969-1973			Long	10.5"	1-1/16" x 10
		1973-1974			Long	11"	1-1/16" x 10
		1973-1974			Diaph	11"	1-1/16" x 10
	5.8L (351ci) V8	1968-1974			Long	11"	1-1/16" x 10
		1968-1974			Diaph	11"	1-1/16" x 10
	6.4L (390ci) V8	1968-1969	Fe Big Block		Long	11"	1-1/16" x 10
		1968-1969	Fe Big Block		Diaph	11"	1-1/16" x 10
	7.0L (427ci) V8	1965-1970	Fe Big Block	4, 19	Diaph	12"	1-3/8" x 10
7.0L (428ci) V8	1966-1970	Fe Big Block	4, 19	Diaph	12"	1-3/8" x 10	
7.0L (429ci) V8	1968-1973		4, 19	Diaph	12"	1-3/8" x 10	
MERCURY							
Brougham, Cyclone, Marquis, Montclair, Monterey, Park Lane	4.3L (260ci) V8	1963-1965			Long	10.5"	1-1/16" x 10
		1963-1965			Diaph	10"	1-1/16" x 10
	5.0L (302ci) V8	1968-1971			Diaph	10"	1-1/16" x 10
		1968-1971			Long	10.5"	1-1/16" x 10
	5.8L (351ci) V8	1971-1972			Long	11"	1-1/16" x 10
		1971-1972			Diaph	11"	1-1/16" x 10
	6.4L (390ci) V8	1963-1970			Long	11"	1-1/16" x 10
		1963-1970			Diaph	11"	1-1/16" x 10
	6.6L (406ci) V8	1962-1963			Long	11"	1-1/16" x 10
					Diaph	11"	1-1/16" x 10
Capri	5.0L (302ci) V8	1979-1985	T-5		Diaph	10"	1-1/16" x 10
		1986	T-5		Diaph	10.5"	1-1/16" x 10
Comet	6 Cylinder						
	4.1L (250ci) 6L	1971-1977			Diaph	10"	1-1/16" x 10
	8 Cylinder						
	3.6L (221ci) V8	1963			Diaph	10"	1-1/16" x 10
		1963			Long	10.5"	1-1/16" x 10
	4.3L (260ci) V8	1963-1966			Long	10.5"	1-1/16" x 10
		1963-1964			Diaph	10"	1-1/16" x 10
	4.7L (289ci) V8	1966-1968			Long	10.5"	1-1/16" x 10
		1966-1968			Diaph	10"	1-1/16" x 10
	5.0L (302ci) V8	1969-1974			Diaph	10"	1-1/16" x 10
		1969-1974			Long	10.5"	1-1/16" x 10
	5.8L (351ci) V8	1968-1973			Long	11"	1-1/16" x 10
		1968-1973			Diaph	11"	1-1/16" x 10
	6.4L (390ci) V8	1966-1969			Long	11"	1-1/16" x 10
		1966-1969			Diaph	11"	1-1/16" x 10

For Footnote references, please see page 45.

PERFORMANCE STREET GUIDE

Clutch Kit Assemblies Application Guide - Cars (cont.)

Street Pro	HP	Super Street Pro	HP	RST Twin	HP	RXT Twin	HP	Street Twin	HP
75113	375	75213	500	6913-03	800	6923-03	1000	6430203	1200
N/A		75233	500	6913-03	800	6923-03	1000	6430203	1200
75111	400	75211	550	6911-03	800	6921-03	1000	6430203	1200
75112	400	75212	550	6911-03	800	6921-03	1000	6430203	1200
75111	400	75211	550	6911-03	800	6921-03	1000	6430203	1200
75112	400	75212	550	6911-03	800	6921-03	1000	6430203	1200
75111	400	75211	550	6911-03	800	6923-03	1000	6430403	1200
75112	400	75212	550	6911-03	800	6921-03	1000	6430403	1200
N/A		75235	600	6911-06	800	6921-06	1000	64304B06	1200
N/A		75235	600	6911-06	800	6921-06	1000	64304B06	1200
N/A		75235	600	6911-06	800	6921-06	1000	64305B06	1200
N/A	375	75233	500	6913-03	800	6923-03	1000	64301B03	1200
75113	375	75213	500	6913-03	800	6923-03	1000	6430103	1200
75113	375	75213	500	6913-03	800	6923-03	1000	6430203	1200
N/A	375	75233	500	6913-03	800	6923-03	1000	64302B03	1200
75111	400	75211	550	6911-03	800	6921-03	1000	64302B03	1200
75112	400	75212	550	6911-03	800	6921-03	1000	6430203	1200
75111	400	75211	550	6911-03	800	6921-03	1000	6430403	1200
75112	400	75212	550	6911-03	800	6921-03	1000	6430403	1200
75111	400	75211	550	6911-03	800	6921-03	1000	64304B03	1200
75112	400	75212	550	6911-03	800	6921-03	1000	6430403	1200
75115	375	75215	500	6913-03	800	6923-03	1000	6430103	1200
75103	375	75203	500	6913-03	800	6923-03	1000	6430103	1200
75113	375	75213	500	6913-03	800	6923-03	1000	N/A	
75113	375	75213	500	6913-03	800	6923-03	1000	6430103	1200
N/A	375	75233	500	6913-03	800	6923-03	1000	6430103	1200
N/A	375	75233	500	6913-03	800	6923-03	1000	6430103	1200
75113	375	75213	500	6913-03	800	6923-03	1000	6430103	1200
N/A	375	75233	500	6913-03	800	6923-03	1000	6430103	1200
75113	375	75213	500	6913-03	800	6923-03	1000	6430103	1200
75113	375	75213	500	6913-03	800	6923-03	1000	6430203	1200
N/A	375	75233	500	6913-03	800	6923-03	1000	6430203	1200
75111	400	75211	550	6911-03	800	6921-03	1000	6430203	1200
75112	400	75212	550	6911-03	800	6921-03	1000	6430203	1200
75111	400	75211	550	6911-03	800	6921-03	1000	6430403	1200
75112	400	75212	550	6911-03	800	6921-03	1000	6430403	1200

PERFORMANCE STREET GUIDE

Clutch Kit Assemblies Application Guide - Cars (cont.)

Make & Model	Engine	Year	Vehicle Option	Foot Note	Type	Stock Size	Spline
Cougar	4.7L (289ci) V8	1967			Long	10.5"	1-1/16" x 10
		1967			Diaph	10"	1-1/16" x 10
	5.0L (302ci) V8	1968-1974			Diaph	10"	1-1/16" x 10
		1968-1974			Long	10.5"	1-1/16" x 10
	5.8L (351ci) V8	1968-1973			Long	11"	1-1/16" x 10
		1968-1973			Diaph	11"	1-1/16" x 10
6.4L (390ci) V8	1966-1969			Long	11"	1-1/16" x 10	
	1966-1969			Diaph	11"	1-1/16" x 10	
OLDSMOBILE							
Cutlass	6 Cylinder						
	3.8L (231ci) V6	1979-1981			Diaph	10.5"	1-1/8" x 10
	8 Cylinder						
	5.4L (330ci) V8	1964-1967			Diaph	10.5"	1-1/8" x 10
	5.7L (350ci) V8	1968-1970	4 Speed		Diaph	10.5"	1-1/8" x 10
		1971-1974	3 Speed		Diaph	10.5"	1-1/8" x 10
		1971-1974	4 Speed		Diaph	10.5"	1-1/8" x 26
		1971-1974	W31 Eng 4 Speed		Diaph	11"	1-1/8" x 26
	7.4L (455ci) V8	1968-1973	3 Speed		Diaph	11"	1-1/8" x 10
		1970-1972	4 Speed		Diaph	11"	1-1/8" x 26
Delta, F85, Jet Star, Vista Cruiser, 88, 442	5.4L (330ci) V8	1964-1967			Diaph	10.5"	1-1/8" x 10
	5.7L (350ci) V8	1968-1970	4 Speed		Diaph	10.5"	1-1/8" x 10
		1971-1974	3 Speed		Diaph	10.5"	1-1/8" x 10
		1971-1974	4 Speed		Diaph	10.5"	1-1/8" x 26
		1971-1974	W31 Eng 4 Speed		Diaph	11"	1-1/8" x 26
		1975-1976			Diaph	11"	1-1/8" x 26
	6.6L (400ci) V8	1964-1970	W30		Diaph	11"	1-1/8" x 10
	7.0L (425ci) V8	1965			Diaph	10.5"	1-1/8" x 10
		1967-1967			Diaph	11"	1-1/8" x 10
	7.4L (455ci) V8	1968-1973	3 Speed		Diaph	11"	1-1/8" x 10
1970-1972		4 Speed		Diaph	11"	1-1/8" x 26	
PLYMOUTH							
Barracuda, Cuda, Road-runner	4.5L (273ci) V8	1965-1967			Diaph	10.5"	1" x 23
	5.2L (318ci) V8	1966-1975			Diaph	10.5"	1" x 23
	5.6L (340ci) V8	1966-1975			Diaph	10.5"	1" x 23
	5.9L (360ci) V8	1974-1975		13	Diaph	10.5"	1" x 23
	6.3L (383ci) V8	1968-1971			Diaph	10.5"	1" x 23
	6.3L (383ci) V8	1968-1971	With Cast Crank	13	Diaph	10.5"	1" x 23
	6.6L (400ci) V8	1972-1974		13	Diaph	10.5"	1" x 23
	7.0L (426ci) V8	1970-1971			B&B	10.95"	1-3/16" x 18
	7.2L (440ci) V8	1970-1972			B&B	10.95"	1-3/16" x 18

For Footnote references, please see page 45.

PERFORMANCE STREET GUIDE

Clutch Kit Assemblies Application Guide - Cars (cont.)

Street Pro	HP	Super Street Pro	HP	RST Twin	HP	RXT Twin	HP	Street Twin	HP
N/A	375	75233	500	6913-03	800	6923-03	1000	6430103	1200
75113	375	75213	500	6913-03	800	6923-03	1000	6430103	1200
75113	375	75213	500	6913-03	800	6923-03	1000	6430103	1200
N/A	375	75233	500	6913-03	800	6923-03	1000	6430103	1200
75111	400	75211	550	6911-03	800	6921-03	1000	6430203	1200
75112	400	75212	550	6911-03	800	6921-03	1000	6430203	1200
75111	400	75211	550	6911-03	800	6921-03	1000	6430403	1200
75112	400	75212	550	6911-03	800	6921-03	1000	6430403	1200
75117	375	75217	500	6913-04	800	6923-04	1000	N/A	
75117	375	75217	500	6913-04	800	6923-04	1000	6410504	1200
75117	375	75217	500	6913-04	800	6923-04	1000	6410504	1200
75117	375	75217	500	6913-04	800	6923-04	1000	6410504	1200
75125	375	75225	500	6913-07	800	6923-07	1000	6410507	1200
75121	400	75221	550	6911-07	800	6921-07	1000	6410507	1200
75124	400	75224	550	6911-04	800	6921-04	1000	6410504	1200
75121	400	75221	550	6911-07	800	6921-07	1000	6410507	1200
75117	375	75217	500	6913-04	800	6923-04	1000	6410504	1200
75117	375	75217	500	6913-04	800	6923-04	1000	6410504	1200
75117	375	75217	500	6913-04	800	6923-04	1000	6410504	1200
75125	375	75225	500	6913-07	800	6923-07	1000	6410507	1200
75121	400	75221	550	6911-07	800	6921-07	1000	6410507	1200
75121	400	75221	550	6911-07	800	6921-07	1000	6410507	1200
75124	400	75224	550	6911-04	800	6921-04	1000	6410404	1200
75117	375	75217	500	6913-04	800	6923-04	1000	6410404	1200
75124	400	75224	550	6911-04	800	6921-04	1000	6410404	1200
75124	400	75224	550	6911-04	800	6921-04	1000	6410504	1200
75121	400	75221	550	6911-07	800	6921-07	1000	6410507	1200
75109	375	75209	500	6913-02	800	6923-02	1000	6440602	1200
75109	375	75209	500	6913-02	800	6923-02	1000	6440602	1200
75109	375	75209	500	6913-02	800	6923-02	1000	6440602	1200
75109	375	75209	500	6913-02	800	6923-02	1000	6440602 (13)	1200
75109	375	75209	500	6913-02	800	6923-02	1000	6440602	1200
75109	375	75209	500	6913-02	800	6923-02	1000	6440602 (13)	1200
75109	375	75209	500	6913-02	800	6923-02	1000	6440602 (13)	1200
75139	400	75239	550	6913-05	800	6923-05	1000	6440805	1200
75139	400	75239	550	6913-05	800	6923-05	1000	6440605	1200

PERFORMANCE STREET GUIDE

Clutch Kit Assemblies Application Guide - Cars (cont.)

Make & Model	Engine	Year	Vehicle Option	Foot Note	Type	Stock Size	Spline	
Belvedere	4.5L (273ci) V8	1962-1967			Diaph	10.5"	1" x 23	
	5.2L (318ci) V8	1961-1971			Diaph	10.5"	1" x 23	
	5.9L (361ci) V8	1963-1966			Diaph	10.5"	1" x 23	
	6.3L (383ci) V8	1969-1970			Diaph	10.5"	1" x 23	
	6.3L (383ci) V8	1969-1970	With Cast Crank	13	Diaph	10.5"	1" x 23	
	7.0L (426ci) V8	1963-1969			B&B	10.95"	1-3/16" x 18	
		1966-1969			B&B	11"	1-3/16" x 18	
7.2L (440ci) V8	1967-1969			B&B	10.95"	1-3/16" x 18		
Duster, Scamp, Valiant, Volare	4.5L (273ci) V8	1964-1969			Diaph	10.5"	1" x 23	
	5.9L (360ci) V8	1968-1974		13	Diaph	10.5"	1" x 23	
Fury, Gran Fury, GT, GTX, Savoy	6.6L (400ci) V8	1971-1974		13	Diaph	10.5"	1" x 23	
	7.0L (426ci) V8	1963-1967			B&B	10.95"	1-3/16" x 18	
		1966-1969			B&B	11"	1-3/16" x 18	
	7.0L (426ci) V8	1970-1971	Small Flywheel		B&B	10.95"	1-3/16" x 18	
	7.2L (440ci) V8	1967-1969	Large Flywheel		B&B	11"	1-3/16" x 18	
7.2L (440ci) V8	1970-1972	Large Flywheel		B&B	10.95"	1-3/16" x 18		
Satellite, GTX	4.5L (273ci) V8	1965-1966			Diaph	10.5"	1" x 23	
	5.2L (318ci) V8	1961-1978			Diaph	10.5"	1" x 23	
	5.5L (330ci) V8	1961-1972			Diaph	10.5"	1" x 23	
	5.6L (340ci) V8	1968-1972			Diaph	10.5"	1" x 23	
	5.9L (360ci) V8	1968-1973		13	Diaph	10.5"	1" x 23	
	6.3L (383ci) V8	1969-1971			Diaph	10.5"	1" x 23	
	6.3L (383ci) V8	1969-1971	With Cast Crank	13	Diaph	10.5"	1" x 23	
	6.6L (400ci) V8	1972-1974		13	Diaph	10.5"	1" x 23	
	7.0L (426ci) V8	1969-1971	Small Flywheel		B&B	10.95"	1-3/16" x 18	
		1969-1972	Large Flywheel		B&B	11"	1-3/16" x 18	
7.2L (440ci) V8	1969-1973	Large Flywheel		B&B	10.95"	1-3/16" x 18		
PONTIAC								
Bonneville, Catalina, Ventura	5.3L (326ci) V8	1963-1964			Diaph	10.5"	1-1/8" x 10	
		1965-1967			Diaph	10.5"	1-1/8" x 10	
	5.7L (350ci)	1970-1972			Diaph	10.5"	1-1/8" x 10	
	6.4L (389ci) V8	1961-1964			Diaph	10.5"	1-1/8" x 10	
		1965-1966			Diaph	11"	1-1/8" x 10	
	6.6L (400ci) V8	1967-1968			9	Diaph	10.5"	1-1/8" x 10
		1970-1972	2 Barrel Carb.			Diaph	11"	1-1/8" x 10
		1971-1972	4 Speed	9	Diaph	10.5"	1-1/8" x 26	
	6.9L (421ci) V8	1964			11	Diaph	10.5"	1-1/8" x 10
		1965-1966				Diaph	11"	1-1/8" x 10
	7.0L (428ci) V8	1967-1969			9	Diaph	11"	1-1/8" x 10
7.5L (455ci) V8	1970-1971	3 Speed	9	Diaph	11"	1-1/8" x 10		
	1971-1972	4 Speed	9	Diaph	11"	1-1/8" x 26		

For Footnote references, please see page 45.

PERFORMANCE STREET GUIDE

Clutch Kit Assemblies Application Guide - Cars (cont.)

Street Pro	HP	Super Street Pro	HP	RST Twin	HP	RXT Twin	HP	Street Twin	HP
75109	375	75209	500	6913-02	800	6923-02	1000	N/A	
75109	375	75209	500	6913-02	800	6923-02	1000	6440602	1200
75109	375	75209	500	6913-02	800	6923-02	1000	N/A	
75109	375	75209	500	6913-02	800	6923-02	1000	6440602	1200
75109	375	75209	500	6913-02	800	6923-02	1000	6440602 (13)	1200
75139	400	75239	550	6913-05	800	6923-05	1000	6440805	1200
75140	400	75240	550	6911-05	800	6921-05	1000	6442805	1200
75139	400	75239	550	6913-05	800	6923-05	1000	6440605	1200
75109	375	75209	500	6913-02	800	6923-02	1000	6440602	1200
75109	375	75209	500	6913-02	800	6923-02	1000	6440602 (13)	1200
75109	375	75209	500	6913-02	800	6923-02	1000	6440602 (13)	1200
75139	400	75239	550	6913-05	800	6923-05	1000	6440805	1200
75140	400	75240	550	6911-05	800	6921-05	1000	6442805	1200
75139	400	75239	550	6913-05	800	6923-05	1000	6440805	1200
75140	400	75240	550	6911-05	800	6921-05	1000	6442605	1200
75139	400	75239	550	6913-05	800	6923-05	1000	6440605	1200
75109	375	75209	500	6913-02	800	6923-02	1000	N/A	
75109	375	75209	500	6913-02	800	6923-02	1000	6440602	1200
75109	375	75209	500	6913-02	800	6923-02	1000	N/A	
75109	375	75209	500	6913-02	800	6923-02	1000	6440602	1200
75109	375	75209	500	6913-02	800	6923-02	1000	6440602 (13)	1200
75109	375	75209	500	6913-02	800	6923-02	1000	6440602	1200
75109	375	75209	500	6913-02	800	6923-02	1000	6440602 (13)	1200
75109	375	75209	500	6913-02	800	6923-02	1000	6440602 (13)	1200
75139	400	75239	550	6913-05	800	6923-05	1000	6440805	1200
75140	400	75240	550	6911-05	800	6921-05	1000	6442805	1200
75139	400	75239	550	6913-05	800	6923-05	1000	6440605	1200
75117	375	75217	500	6913-04	800	6923-04	1000	N/A	
75117	375	75217	500	6913-04	800	6923-04	1000	6420104	1200
75117	375	75217	500	6913-04	800	6923-04	1000	6420104	1200
75117	375	75217	500	6913-04	800	6923-04	1000	N/A	
75124	400	75224	550	6911-04	800	6921-04	1000	6420104	
75117	375	75217	500	6913-04	800	6923-04	1000	6420104	1200
75124	400	75224	550	6911-04	800	6921-04	1000	6420104	
75125	375	75225	500	6913-07	800	6923-07	1000	6420107	1200
75117	375	75217	500	6913-04	800	6923-04	1000	N/A	
75124	400	75224	550	6911-04	800	6921-04	1000	6420104	1200
75124	400	75224	550	6911-04	800	6921-04	1000	6420104	1200
75124	400	75224	550	6911-04	800	6921-04	1000	6420104	1200
75121	400	75221	550	6911-07	800	6921-07	1000	6420107	1200

PERFORMANCE STREET GUIDE

Clutch Kit Assemblies Application Guide - Cars (cont.)

Make & Model	Engine	Year	Vehicle Option	Foot Note	Type	Stock Size	Spline	
Firebird, Trans Am	6 Cylinder							
	3.8L (231ci) V6	1980-1981			Diaph	10.5"	1-1/8" x 10	
	4.1L (250ci) 6L	1979			Diaph	10.5"	1-1/8" x 10	
	8 Cylinder							
	4.9L (301ci) V8	1977-1981			Diaph	10.5"	1-1/8" x 10	
	5.0L (305ci) V8	1976-1978				Diaph	10.5"	1-1/8" x 10
		1979-1980	4 Speed 10 Spline			Diaph	10.5"	1-1/8" x 10
		1981	Except California			Diaph	10.5"	1-1/8" x 10
		1981	California			Diaph	10.5"	1-1/8" x 26
		1982-1984	4 & 5 Speed			Diaph	10.5"	1-1/8" x 10
		1986-1992			3	Diaph	10.5"	1-1/8" x 26
	5.4L (326ci) V8	1967				Diaph	10.5"	1-1/8" x 10
	5.7L (350ci) V8	1968-1974	3 Speed		3,11	Diaph	10.5"	1-1/8" x 10
		1968-1974	4 Speed		11	Diaph	10.5"	1-1/8" x 26
		1975-1978	3 Speed		11	Diaph	10.5"	1-1/8" x 10
		1975-1978	4 Speed		11	Diaph	10.5"	1-1/8" x 26
		1983-1992			3,11	Diaph	10.5"	1-1/8" x 26
		1993-1997	LT-1 6 Speed Pull Type			Diaph	11"	1-1/8" x 26
		1998-2002	LS1		1,10,16	Diaph	12"	1-1/8" x 26
	6.6L (400ci) V8	1967-1970	3 Speed		11	Diaph	10.5"	1-1/8" x 10
		1967-1970	4 Speed			Diaph	11"	1-1/8" x 10
		1971-1972	3 Speed			Diaph	10.5"	1-1/8" x 10
		1971-1972	4 Speed			Diaph	10.5"	1-1/8" x 26
1973-1977		4 Speed			Diaph	10.5"	1-1/8" x 26	
1977-1979		3 & 4 Speed			Diaph	11"	1-1/8" x 26	
7.0L (428ci) V8	1967-1969				Diaph	11"	1-1/8" x 10	
7.4L (455ci) V8	1971-1976				Diaph	11"	1-1/8" x 26	
G8	6.2L (376ci) V8	2008-2009	LS3 T56	16,17,21	Diaph	12"	1-1/8" x 26	
Grand Am (RWD)	6 Cylinder							
	3.8L (231ci) V6	1979			Diaph	10.5"	1-1/8" x 10	
	8 Cylinder							
	4.9L (301ci) V8	1978-1980			Diaph	10.5"	1-1/8" x 10	
	5.0L (305ci) V8	1978-1979			Diaph	10.5"	1-1/8" x 10	
	6.6L (400ci) V8	1973-1974	4 Speed		Diaph	10.5"	1-1/8" x 26	
7.4L (455ci) V8	1973-1975	4 Speed 4 Barrel		Diaph	10.5"	1-1/8" x 26		
Grand Prix	6 Cylinder							
	3.8L (231ci) V6	1978			Diaph	10.5"	1-1/8" x 10	
Grand Prix	8 Cylinder							
	5.4L (326ci) V8	1963-1967			Diaph	10.5"	1-1/8" x 10	
	5.7L (350ci) V8	1968-1978				Diaph	10.5"	1-1/8" x 10
1968-1977		4 Speed Muncie			Diaph	10.5"	1-1/8" x 26	

For Footnote references, please see page 45.

PERFORMANCE STREET GUIDE

Clutch Kit Assemblies Application Guide - Cars (cont.)

Street Pro	HP	Super Street Pro	HP	RST Twin	HP	RXT Twin	HP	Street Twin	HP
75117	375	75217	500	6913-04	800	6923-04	1000	N/A	
75117	375	75217	500	6913-04	800	6923-04	1000	N/A	
75117	375	75217	500	6913-04	800	6923-04	1000	6420104	1200
75117	375	75217	500	6913-04	800	6923-04	1000	6400104	1200
75117	375	75217	500	6913-04	800	6923-04	1000	6400104	1200
75117	375	75217	500	6913-04	800	6923-04	1000	6400104	1200
75125	375	75225	500	6913-07	800	6923-07	1000	6400107	1200
75117	375	75217	500	6913-04	800	6923-04	1000	6420104	1200
75125	375	75225	500	6913-07	800	6923-07	1000	6400207 (3)	1200
75117	375	75217	500	6913-04	800	6923-04	1000	6420104	1200
75117	375	75217	500	6913-04	800	6923-04	1000	6420104 (3)	1200
75125	375	75225	500	6913-07	800	6923-07	1000	6420107	1200
75117	375	75217	500	6913-04	800	6923-04	1000	6420104	1200
75125	375	75225	500	6913-07	800	6923-07	1000	6420107	1200
75125	375	75225	500	6913-07	800	6923-07	1000	CALL	1200
75116	400	75216	550	N/A		N/A		6402207	1200
75123	425	75223	600	6912-07	800	6932-07	1000	64050B07	1200
75117	375	75232	500	6913-04	800	6923-04	1000	6420104	1200
75124	400	75224	550	6911-04	800	6921-04	1000	6420104	1200
75117	375	75232	500	6913-04	800	6923-04	1000	6420104	1200
75125	375	75226	500	6913-07	800	6923-07	1000	6420107	1200
75125	375	75226	500	6913-07	800	6923-07	1000	6420107	1200
75121	400	75221	550	6911-07	800	6921-07	1000	6420107	1200
75124	400	75224	550	6911-04	800	6921-04	1000	6420104	1200
75121	400	75221	550	6911-07	800	6921-07	1000	6420107	1200
N/A		N/A		6405507		64405507M	1000	6404807	1200
75117	375	75217	550	6913-04	800	6923-04	1000	N/A	
75117	375	75217	500	6913-04	800	6923-04	1000	6420104	1200
75117	375	75217	500	6913-04	800	6923-04	1000	6400104	1200
75125	375	75225	500	6913-07	800	6923-07	1000	6420107	1200
75125	375	75225	500	6913-07	800	6923-07	1000	6420107	1200
75117	375	75217	500	6913-04	800	6923-04	1000	N/A	
75117	375	75217	500	6913-04	800	6923-04	1000	6420104	1200
75117	375	75217	500	6913-04	800	6923-04	1000	6420104	1200
75125	375	75225	500	6913-07	800	6923-07	1000	6420107	1200

PERFORMANCE STREET GUIDE

Clutch Kit Assemblies Application Guide - Cars (cont.)

Make & Model	Engine	Year	Vehicle Option	Foot Note	Type	Stock Size	Spline
Grand Prix	6.4L (389ci) V8	1962-1964			Diaph	10.5"	1-1/8" x 10
		1965-1966			Diaph	11"	1-1/8" x 10
	6.6L (400ci) V8	1967-1979	3 Speed	11	Diaph	10.5"	1-1/8" x 10
		1967-1979	4 Speed	11	Diaph	10.5"	1-1/8" x 26
	6.9L (421ci) V8	1964		11	Diaph	10.5"	1-1/8" x 10
		1965-1966			Diaph	11"	1-1/8" x 10
	7.0L (428ci) V8	1967-1970			Diaph	11"	1-1/8" x 10
	7.5L (455ci) V8	1970-1971	3 Speed		Diaph	11"	1-1/8" x 10
1971-1976		4 Speed		Diaph	11"	1-1/8" x 26	
GTO	5.7L (350ci) V8	2004	LS1 6 Speed	17,21	Diaph	12"	1-1/8" x 26
	5.7L (350ci) V8	2005-2006	LS2 6 Speed	17,21	Diaph	12"	1-1/8" x 26
	6.4L (389ci) V8	1964-1966			Diaph	10.5"	1-1/8" x 10
	6.6L (400ci) V8	1967-1974	3 Speed	11	Diaph	10.5"	1-1/8" x 10
		1967-1979	4 Speed 4 Barrel	11	Diaph	10.5"	1-1/8" x 10
		1967-1974	4 Speed Muncie		Diaph	11"	1-1/8" x 26
	7.5L (455ci) V8	1970-1973	3 Speed		Diaph	11"	1-1/8" x 10
		1970-1973	4 Speed		Diaph	11"	1-1/8" x 26
Lemans	6 Cylinder						
	3.8L (231ci) V6	1979			Diaph	10.5"	1-1/8" x 10
	8 Cylinder						
	4.3L (260ci) V8	1976			Diaph	10.5"	1-1/8" x 10
	4.9L (301ci) V8	1979			Diaph	10.5"	1-1/8" x 10
	5.4L (326ci) V8	1963-1967			Diaph	10.5"	1-1/8" x 10
	5.7L (350ci) V8	1968-1977	3 Speed & 4 Speed	11	Diaph	10.5"	1-1/8" x 10
	6.4L (389ci) V8	1965-1966	2 Barrel		Diaph	10.5"	1-1/8" x 10
		1965-1966	4 Barrel		Diaph	11"	1-1/8" x 10
	6.6L (400ci) V8	1967-1972	3 Speed	11	Diaph	10.5"	1-1/8" x 10
		1967-1977	4 Speed Muncie	11	Diaph	10.5"	1-1/8" x 26
	7.5L (455ci) V8	1970-1971	3 Speed		Diaph	11"	1-1/8" x 10
		1971-1973	4 Speed		Diaph	11"	1-1/8" x 26
	Phoenix	6 Cylinder					
3.8L (231ci) V6		1979			Diaph	10.5"	1-1/8" x 10
8 Cylinder							
5.0L (305ci) V8		1977-1979			Diaph	10.5"	1-1/8" x 10
5.7L (350ci) V8		1977			Diaph	10.5"	1-1/8" x 10
Tempest, T37	6 Cylinder						
	3.8L (230ci) 6L	1966-1967			Diaph	10.5"	1-1/8" x 10
	4.1L (250ci) 6L	1968-1976			Diaph	10.5"	1-1/8" x 10
	8 Cylinder						
	4.3L (260ci) V8	1975-1976			Diaph	10.5"	1-1/8" x 10
	5.0L (305ci) V8	1977	2 Barrel 3 Speed	12	Diaph	10.5"	1-1/8" x 10
	5.4L (326ci) V8	1963-1967			Diaph	10.5"	1-1/8" x 10

For Footnote references, please see page 45.

PERFORMANCE STREET GUIDE

Clutch Kit Assemblies Application Guide - Cars (cont.)

Street Pro	HP	Super Street Pro	HP	RST Twin	HP	RXT Twin	HP	Street Twin	HP
75117	375	75217	500	6913-04	800	6923-04	1000	N/A	
75124	400	75224	550	6911-04	800	6921-04	1000	6420104	1200
75117	375	75217	500	6913-04	800	6923-04	1000	6420104	1200
75125	375	75225	500	6913-07	800	6923-07	1000	6420107	1200
75117	375	75217	500	6913-04	800	6923-04	1000	N/A	
75124	400	75224	550	6911-04	800	6921-04	1000	6420104	1200
75124	400	75224	550	6911-04	800	6921-04	1000	6420104	1200
75124	400	75224	550	6911-04	800	6921-04	1000	6420104	1200
75121	400	75221	550	6911-07	800	6921-07	1000	6420107	1200
75123	425	75223	600	6912-07	800	6932-07	1000	6404807	1200
75152	425	75223	600	6912-07	800	6932-07	1000	6404807	1200
75117	375	75217	500	6913-04	800	6923-04	1000	6420104	1200
75117	375	75217	500	6913-04	800	6923-04	1000	6420104	1200
75117	375	75217	500	6913-04	800	6923-04	1000	6420104	1200
75121	400	75221	550	6911-07	800	6921-07	1000	6420107	1200
75124	400	75224	550	6911-04	800	6921-04	1000	6420104	1200
75121	400	75221	550	6911-07	800	6921-07	1000	6420107	1200
75117	375	75217	500	6913-04	800	6923-04	1000	N/A	
75117	375	75217	500	6913-04	800	6923-04	1000	6420104	1200
75117	375	75217	500	6913-04	800	6923-04	1000	6400104	1200
75117	375	75217	500	6913-04	800	6923-04	1000	6420104	1200
75117	375	75217	500	6913-04	800	6923-04	1000	6420104	1200
75117	375	75217	500	6913-04	800	6923-04	1000	6420104	1200
75124	400	75224	550	6911-04	800	6921-04	1000	6420104	1200
75117	375	75217	500	6913-04	800	6923-04	1000	6420104	1200
75125	375	75225	500	6913-07	800	6923-07	1000	6420107	1200
75124	400	75224	550	6911-04	800	6921-04	1000	6420104	1200
75121	400	75221	550	6911-07	800	6921-07	1000	6420107	1200
75117	375	75217	500	6913-04	800	6923-04	1000	N/A	
75117	375	75217	500	6913-04	800	6923-04	1000	6400104	1200
75117	375	75217	500	6913-04	800	6923-04	1000	6420104	1200
75117	375	75217	500	6913-04	800	6923-04	1000	N/A	
75117	375	75217	500	6913-04	800	6923-04	1000	N/A	
75117	375	75217	500	6913-04	800	6923-04	1000	6420104	1200
75117	375	75217	500	6913-04	800	6923-04	1000	N/A	1200
75117	375	75217	500	6913-04	800	6923-04	1000	6420104	1200

Performance Street Guide

PERFORMANCE STREET GUIDE

Clutch Kit Assemblies Application Guide - Cars (cont.)

Make & Model	Engine	Year	Vehicle Option	Foot Note	Type	Stock Size	Spline	
Tempest, T37	5.7L (350ci) V8	1968-1977	3 Speed	11	Diaph	10.5"	1-1/8" x 10	
		1971-1974	4 Speed	11	Diaph	10.5"	1-1/8" x 26	
		1975-1977	3 Speed 26 Spline	11	Diaph	10.5"	1-1/8" x 26	
	6.4L (389ci) V8	1963-1967	2 Barrel		Diaph	10.5"	1-1/8" x 10	
		1965-1966	4 Barrel		Diaph	11"	1-1/8" x 10	
	6.6L (400ci) V8	1967-1972			11	Diaph	10.5"	1-1/8" x 10
		1971-1977	4 Speed Muncie		11	Diaph	10.5"	1-1/8" x 26
	7.5L (455ci) V8	1970-1971	3 Speed			Diaph	11"	1-1/8" x 10
1971-1973		4 Speed			Diaph	11"	1-1/8" x 26	
Ventura	6 Cylinder							
	4.1L (250ci) 6L	1971-1976			Diaph	10.5"	1-1/8" x 10	
	8 Cylinder							
	4.3L (260ci) V8	1975-1976		12	Diaph	10.5"	1-1/8" x 10	
	5.0L (305ci) V8	1977	2 Barrel 3 Speed	12	Diaph	10.5"	1-1/8" x 10	
	5.0L (307ci)	1971-1972			Diaph	10.5"	1-1/8" x 26	
	5.7L (350ci) V8	1972-1977	3 Speed 10 Spline	11	Diaph	10.5"	1-1/8" x 10	
		1972-1974	4 Speed	11	Diaph	10.5"	1-1/8" x 26	
1975-1977		3 Speed 26 Spline	11	Diaph	10.5"	1-1/8" x 26		

For Footnote references, please see page 45.



PERFORMANCE STREET GUIDE

Clutch Kit Assemblies Application Guide - Cars (cont.)

Street Pro	HP	Super Street Pro	HP	RST Twin	HP	RXT Twin	HP	Street Twin	HP
75117	375	75217	500	6913-04	800	6923-04	1000	6420104	1200
75125	375	75225	500	6913-07	800	6923-07	1000	6420107	1200
75125	375	75225	500	6913-07	800	6923-07	1000	N/A	
75117	375	75217	500	6913-04	800	6923-04	1000	6420104	1200
75124	400	75224	550	6911-04	800	6921-04	1000	6420104	1200
75117	375	75217	500	6913-04	800	6923-04	1000	6420104	1200
75125	375	75225	500	6913-07	800	6923-07	1000	6420107	1200
75124	400	75224	550	6911-04	800	6921-04	1000	6420104	1200
75121	400	75221	550	6911-07	800	6921-07	1000	6420107	1200
75117	375	75217	500	6913-04	800	6923-04	1000	N/A	
75117	375	75217	500	6913-04	800	6923-04	1000	6420104	1200
75117	375	75217	500	6913-04	800	6923-04	1000	N/A	
75125	375	75225	500	6913-07	800	6923-07	1000	N/A	
75117	375	75217	500	6913-04	800	6923-04	1000	6420104	1200
75125	375	75225	500	6913-07	800	6923-07	1000	6420107	1200
75125	375	75225	500	6913-07	800	6923-07	1000	N/A	

Footnotes:

1. LS1/LS6 use aftermarket flywheel for max holding power. LS2/LS3/LS7 use aftermarket flat LS1 flywheel
2. Street Pro includes OE style Steel Flywheel. Super Street Pro includes billet steel flywheel.
3. For Original Street Pro Flywheel Counterweight Kit 560222 Must Be ordered
4. Original clutch size was 11.5" 12" replaces 11.5"
6. RST & RXT Kits include Steel Flywheel
7. Requires 2009 OEM Bearing
9. 11" kit replaces 12" OE units
10. Street Pro includes OE style Steel Flywheel. Super Street Pro includes billet steel flywheel.
11. OE Kit is 10.5" - Super Street Pros are supplied with 10.95"
12. OE Kit is 10"
13. Requires MOPAR weight kit 564111 for all with this footnote. Exception 383 is 1971 and up steel crank only is needed.
14. 11" Pressure Plate used to replace 10.5"
15. 12" Pressure Plate used to replace 11"
16. Requires large bore master cylinder. Minimum 13/16 bore.
17. May require McLeod Internal HYD Bearing. Call factory.
18. After market flywheel highly recommended.
19. McLeod Hydraulic Bearing 1605 Must be Used
20. Must Use McLeod Flywheel 463458
21. Must Use large Bore Master Cylinder
22. Must Use 07-09 Shelby GT500 Slave Cylinder

PERFORMANCE STREET GUIDE

Clutch Kit Assemblies Application Guide - Trucks

Make & Model	Engine	Year	Vehicle Option	Foot Note	Type	Stock Size	Spline	
CHEVROLET & GMC								
6 Cylinder								
C-G-K-P-R-V Series 10-35, Blazer, Jimmy, Suburban, Tahoe, Yukon	3.2L (194ci) 6L	1963-1976		14	Diaph	10.5"	1-1/8" x 10	
	3.8L (230ci) 6L	1963-1970	1/2 & 3/4 Ton	14	Diaph	10.5"	1-1/8" x 10	
	3.8L (230ci) 6L	1963-1970	1 to 2 Ton		Diaph	12"	1-1/8" x 10	
	3.9L (235ci) 6L	1956-1962			14	Diaph	10.5"	1-1/8" x 10
		1956-1962	H.D. Factory Option			Diaph	12"	1-1/8" x 10
	8 Cylinder							
	4.7L (283ci) V8	1955-1968			15	Diaph	11"	1-1/8" x 10
	4.8L (291ci) V8	1999-2004				Diaph	12"	1-1/8" x 10
	5.0L (305ci) V8	1986-1999	M Engine Code		3	Diaph	12"	1-1/8" x 10
		1976-1985			15	Diaph	11"	1-1/8" x 10
	5.0L (307ci) V8	1969-1973			15	Diaph	11"	1-1/8" x 10
	5.3L (326ci) V8	1999-2006				Diaph	12"	1-1/8" x 10
	5.4L (327ci) V8	1962-1970				Diaph	12"	1-1/8" x 10
	5.7L (350ci) V8	1996-2000	R Engine Code		3	Diaph	12"	1-1/8" x 10
		1992-1995	Tahoe & Yukon K Engine Code		3	Diaph	12"	1-1/8" x 10
		1996	Tahoe & Yukon R Engine Code		3	Diaph	12"	1-1/8" x 10
		1997-2000	Tahoe & Yukon R Engine Code		3	Diaph	12"	1-1/8" x 10
		1988-1995			3	Diaph	12"	1-1/8" x 10
	6.0L (366ci) V8	1999-2000				Diaph	12"	1-1/8" x 10
2001-2006					Diaph	12"	1-1/8" x 10	
6.0L (396ci) V8	1965-1985				Diaph	12"	1-1/8" x 10	
	1986-1995				Diaph	12"	1-1/8" x 10	
6.6L (400ci) V8	1978-1980			3	Diaph	12"	1-1/8" x 10	
6.6L (402ci) V8	1970-1973				Diaph	12"	1-1/8" x 10	
	1999-2002				Diaph	12"	1-1/8" x 10	
7.4L (454ci) V8	1984-1990			3	Diaph	12"	1-1/8" x 10	
	1991-1995			3	Diaph	12"	1-1/8" x 10	
	1996-2000			3	Diaph	12"	1-1/8" x 10	
DODGE								
100, 200, 300, R1500, R2500, R3500	4.7L (287ci) V8	2002-2006			Diaph	12"	1-1/8" x 10	
	5.2L (318ci) V8	1958-1968	Except A100 Models	15	Diaph	11"	1" x 23	
		1968-1987	A100 Models	14	Diaph	10.5"	1" x 23	
		1969-1987	Except A100 Models	15	Diaph	11"	1" x 23	
		1994-2001		15	Diaph	11"	1" x 23	
	5.7L (348ci) V8	2003-2004			Diaph	12"	1-1/8" x 10	
	5.8L (360ci) V8	1971-1987			13	Diaph	11"	1" x 23
		1994-2003				Diaph	12"	1-1/8" x 10

For Footnote references, please see page 51.

PERFORMANCE STREET GUIDE

Clutch Kit Assemblies Application Guide - Trucks (cont.)

Street Pro	HP	Super Street Pro	HP	RST Twin	HP	RXT Twin	HP	Street Twin	HP
75132	375	75232	500	6913-04	800	6923-04	1000		1200
75132	375	75232	500	6913-04	800	6923-04	1000		1200
75128	425	75228	600	6911-04	800	6921-04	1000		1200
75132	375	75232	500	6913-04	800	6923-04	1000	6400104	1200
75128	425	75228	600	6911-04	800	6921-04	1000	6400104	1200
75124	400	75224	550	6911-04	800	6921-04	1000	6400104	1200
75128	425	75229	600	6911-04	800	6921-04	1000	640048B04	1200
75128	425	75228	600	6911-04	800	6921-04	1000	6400104	1200
75128	400	75228	550	6911-04	800	6921-04	1000	6400104	1200
75128	400	75228	550	6911-04	800	6921-04	1000	6400104	1200
75128	425	75228	600	6911-04	800	6921-04	1000	64048B04	1200
75128	425	75228	600	6911-04	800	6921-04	1000	6400104	1200
75128	425	75228	600	6911-04	800	6921-04	1000	6400204	1200
75128	425	75228	600	6911-04	800	6921-04	1000	6400204	1200
75128	425	75228	600	6911-04	800	6921-04	1000	6400204	1200
75128	425	75228	600	6911-04	800	6921-04	1000	6400204	1200
75128	425	75228	600	6912-04	800	6932-04	1000	64048B04	1200
75128	425	75228	600	6912-04	800	6932-04	1000	64048B04	1200
75128	425	75228	600	6911-04	800	6921-04	1000	6400104	1200
75128	425	75228	600	6911-04	800	6921-04	1000	6400104	1200
75128	425	75228	600	6911-04	800	6921-04	1000	6400104	1200
75128	425	75228	600	6911-04	800	6921-04	1000	6400104	1200
75128	425	75228	600	6912-04	800	6932-04	1000	64048B04	1200
75128	425	75228	600	6911-04	800	6921-04	1000	6400104	1200
75128	425	75228	600	6911-04	800	6921-04	1000	6400104	1200
75128	425	75228	600	6911-04	800	6921-04	1000	6400104	1200
75128	425	75228	600	6911-04	800	6921-04	1000		1200
75108	400	75208	550	6911-02	800	6921-02	1000	6442602	1200
75109	375	75209	500	6913-02		6921-02	1000	6442602	1200
75108	400	75208	550	6911-02	800	6921-02	1000	6442602	1200
75108	400	75208	550	6911-02	800	6921-02	1000	6442602	1200
75128	425	75228	600	N/A		N/A		N/A	
75141	400	75241	550	6911-02	800	6921-02	1000	6442602	1200
75128	425	75228	600	N/A		N/A		6442602	1200

PERFORMANCE STREET GUIDE

Clutch Kit Assemblies Application Guide - Trucks (cont.)

Make & Model	Engine	Year	Vehicle Option	Foot Note	Type	Stock Size	Spline	
100, 200, 300, R1500, R2500, R3500	6.3L (383ci) V8	1958-1971			Diaph	12"	1" x 23	
	6.6L (400ci) V8	1972-1981			Diaph	12"	1" x 23	
	7.2L (440ci) V8			Diaph	12"	1" x 23		
	10 Cylinder							
	8.0L (488ci) V10	1994-1997				Diaph	12 1/4"	1 1/4" x 10
	8.0L (488/505ci) V10	1998-2002				Diaph	12 1/4"	1 1/4" x 10
	8.3L (505ci) V10	2004-2006	SRT-10			Diaph	12 1/4"	1 1/4" x 10
FORD								
6 Cylinder								
3.8L (232ci) V6	1981-1982				Diaph	10"	1 1/16" x 10	
	1983				Diaph	10"	1 1/16" x 10	
3.9L (240ci) 6L	1965-1972				Diaph	10"	1 1/16" x 10	
	1965-1972	Factory Option			Diaph	11"	1 1/16" x 10	
4.9L (300ci) 6L	1965-1977	To Y80,000			Diaph	11"	1 1/16" x 10	
	1965-1977	To Y80,000			Long	11"	1 1/16" x 10	
	1977-1980	From Y80,001			Diaph	11"	1 1/16" x 10	
	1980-1982	Under 8500 GVW			Diaph	10"	1 1/16" x 10	
	1980-1982	Over 8500 GVW			Diaph	11"	1 1/16" x 10	
	1983-1992	Under 8500 GVW 4 Speed			Diaph	10"	1 1/16" x 10	
	1983-1992	Over 8500 GVW 4 Speed			Diaph	11"	1 1/16" x 10	
	8/1987-1997	Under 8500 GVW 5 Speed			Diaph	10"	1 1/16" x 10	
8/1987-1997	Over 8500 GVW 5 Speed			Diaph	11"	1 1/16" x 10		
8 Cylinder								
4.2L (255ci) V8	1980-1982				Diaph	10"	1 1/16" x 10	
4.6L (281ci) V8	1997-2000				Diaph	11	1 1/16" x 10	
	2001-2004				Diaph	11	1 1/16" x 10	
4.7L (289ci) V8	1966				Diaph	10"	1 1/16" x 10	
	1967-1969				Diaph	11"	1 1/16" x 10	
5.0L (302ci) V8	1968-1976				Long	11"	1 1/16" x 10	
	1977-1982				Diaph	11"	1 1/16" x 10	
	1983				Diaph	11"	1 1/16" x 10	
	1984-1986	Under 8500 GVW			Diaph	10"	1 1/16" x 10	
	1984-1986	Over 8500 GVW			Diaph	11"	1 1/16" x 10	
	1987				Diaph	11"	1 1/16" x 10	
	8/1987-1993	4 Speed			Diaph	11"	1 1/16" x 10	
	8/1987-1992	5 Speed			Diaph	11"	1 1/16" x 10	

For Footnote references, please see page 51.

PERFORMANCE STREET GUIDE

Clutch Kit Assemblies Application Guide - Trucks (cont.)

Street Pro	HP	Super Street Pro	HP	RST Twin	HP	RXT Twin	HP	Street Twin	HP
75141	425	75241	600	6911-02	800	6921-02	1000	6442602	1200
75141	425	75241	600	6911-02	800	6921-02	1000	6442602	1200
75141	425	75241	600	6911-02	800	6921-02	1000	6442602	1200
N/A		N/A		N/A		N/A		64436B07M	1200
N/A		N/A		N/A		N/A		64436B07M	1200
N/A		N/A		N/A		N/A		64437B07M	1200
75113	375	75213	500	6913-03	800	6923-03	1000	N/A	
75113	375	75213	500	6913-03	800	6923-03	1000	N/A	
75113	375	75213	500	6913-03	800	6923-03	1000	N/A	
75111	400	75211	550	6911-03	800	6921-03	1000	N/A	
75112	400	75212	550	6911-03	800	6921-03	1000	6430203	1200
75111	400	75211	550	6911-03	800	6921-03	1000	64302B03	1200
75112	400	75212	550	6911-03	800	6921-03	1000	6430203	1200
75113	375	75213	500	6913-03	800	6923-03	1000	6430203	1200
75112	400	75212	550	6911-03	800	6921-03	1000	6430203	1200
75115	375	75215	500	6913-03	800	6923-03	1000	6430203	1200
75145	400	75245	550	6911-03	800	6921-03	1000	6430203	1200
75144	375	75244	500	6913-03	800	6923-03	1000	6430203	1200
75143	400	75243	550	6911-03	800	6921-03	1000	6430203	1200
75113	375	75213	500	6913-03	800	6923-03	1000	6430103	1200
75105	400	75205	550	6913-03	800	6923-03	1000	6430103	1200
75104	400	75204	550	6912-03	800	6932-03	1000	6430603	1200
75113	375	75213	500	6913-03	800	6923-03	1000	6430203	1200
75137	400	75237	550	6911-03	800	6921-03	1000	6430203	1200
75111	400	75211	550	6911-03	800	6921-03	1000	6430203	1200
75112	400	75212	550	6911-03	800	6921-03	1000	6430203	1200
75145	400	75245	550	6911-03	800	6921-03	1000	6430203	1200
75115	375	75215	500	6923-03	800	6923-03	1000	6430203	1200
75145	400	75245	550	6911-03	800	6921-03	1000	6430203	1200
75145	400	75245	550	6911-03	800	6921-03	1000	6430203	1200
75145	400	75245	550	6911-03	800	6921-03	1000	6430203	1200
75145	400	75245	550	6911-03	800	6921-03	1000	6430203	1200
75143	400	75243	550	6911-03	800	6921-03	1000	6430203	1200

PERFORMANCE STREET GUIDE

Clutch Kit Assemblies Application Guide - Trucks (cont.)

Make & Model	Engine	Year	Vehicle Option	Foot Note	Type	Stock Size	Spline		
F-Series	5.7L (351ci) V8	1977-1982	351M		Diaph	11"	1 1/16" x 10		
		1981-1983			Diaph	11"	1 1/16" x 10		
		1984-1986	Under 8500 GVW		Diaph	10"	1 1/16" x 10		
		1984-1986	Over 8500 GVW		Diaph	11"	1 1/16" x 10		
		1987			Diaph	11"	1 1/16" x 10		
		8/1987-1993	4 Speed		Diaph	11"	1 1/16" x 10		
		8/1987-1992	5 Speed		Diaph	11"	1 1/16" x 10		
		1993-1994			Diaph	11"	1 1/16" x 10		
		1995-1996			Diaph	11"	1 1/16" x 10		
	6.5L (400ci) V8	1977-1982	400M		Diaph	12"	1 1/16" x 10		
E-Series	6 Cylinder								
	2.8L (170ci) 6L	1969-1972	E300		Diaph	10"	1 1/16" x 10		
	3.9L (240ci) 6L	1965-1971			Diaph	10"	1 1/16" x 10		
	4.9L (300ci) 6L	1965-1977				Diaph	11"	1 1/16" x 10	
		1965-1977				Long	11"	1 1/16" x 10	
		1978-1983				Diaph	11"	1 1/16" x 10	
		1981-1982	Under 8500 GVW			Diaph	10"	1 1/16" x 10	
			Over 8500 GVW			Diaph	11"	1 1/16" x 10	
		1983-1987	Under 8500 GVW			Diaph	10"	1 1/16" x 10	
		8/1987-1990	Under 8500 GVW			Diaph	10"	1 1/16" x 10	
		8/1987-1990	Over 8500 GVW			Diaph	11"	1 1/16" x 10	
	8 Cylinder								
	5.0L (302ci) V8	1968-1977				Diaph	11"	1 1/16" x 10	
		1978-1980				Diaph	11"	1 1/16" x 10	
		1981-1982	Under 8500 GVW			Diaph	10"	1 1/16" x 10	
		1981-1982	Over 8500 GVW			Diaph	11"	1 1/16" x 10	
		1983-1986	Under 8500 GVW			Diaph	10"	1 1/16" x 10	
		1983-1986	Over 8500 GVW			Diaph	11"	1 1/16" x 10	
		1987				Diaph	11"	1 1/16" x 10	
		1988-1990				Diaph	11"	1 1/16" x 10	
		5.7L (351ci) V8	1975-1977				Diaph	11"	1 1/16" x 10
			1975-1977				Long	11"	1 1/16" x 10
			1977-1980				Diaph	11"	1 1/16" x 10
1981-1983						Diaph	11"	1 1/16" x 10	
1983-1987			Under 8500 GVW			Diaph	10"	1 1/16" x 10	
1983-1987	Over 8500 GVW				Diaph	11"	1 1/16" x 10		
8/1987-1990					Diaph	11"	1 1/16" x 10		

For Footnote references, please see page 51.

PERFORMANCE STREET GUIDE

Clutch Kit Assemblies Application Guide - Trucks (cont.)

Street Pro	HP	Super Street Pro	HP	RST Twin	HP	RXT Twin	HP	Street Twin	HP
75134	400	75234	550	6911-03	800	6921-03	1000	6430703	1200
75112	400	75212	550	6911-03	800	6921-03	1000	6430203	1200
75115	375	75215	500	6923-03	800	6923-03	1000	6430203	1200
75145	400	75245	550	6911-03	800	6921-03	1000	6430203	1200
75145	400	75245	550	6911-03	800	6921-03	1000	6430203	1200
75145	400	75245	550	6911-03	800	6921-03	1000	6430203	1200
75143	400	75243	550	6911-03	800	6921-03	1000	6430203	1200
75143	400	75243	550	6911-03	800	6921-03	1000	6430203	1200
75143	400	75243	550	6911-03	800	6921-03	1000	6430203	1200
75143	425	75234	600	6911-03	800	6921-03	1000	6430703	1200
75113	375	75213	500	6913-03	800	6923-03	1000	6430103	1200
75113	375	75213	500	6913-03	800	6923-03	1000	6430103	1200
75117	400	75217	550	6911-03	800	6921-03	1000	6430203	1200
75111	400	75211	550	6911-03	800	6921-03	1000		1200
75112	400	75212	550	6911-03	800	6921-03	1000	6430203	1200
75113	375	75213	500	6913-03	800	6923-03	1000	6430203	1200
75145	400	75245	550	6911-03	800	6921-03	1000	6430203	1200
75115	375	75215	500	6913-03	800	6923-03	1000	6430203	1200
75144	375	75244	500	6913-03	800	6923-03	1000	6430203	1200
75143	400	75243	550	6911-03	800	6921-03	1000	6430203	1200
75112	400	75212	550	6911-03	800	6921-03	1000	6430203	1200
75112	400	75212	550	6911-03	800	6921-03	1000	6430203	1200
75113	375	75213	500	6913-03	800	6923-03	1000	6430203	1200
75112	400	75212	550	6911-03	800	6921-03	1000	6430203	1200
75115	375	75215	500	6913-03	800	6923-03	1000	6430203	1200
75145	400	75245	550	6911-03	800	6921-03	1000	6430203	1200
75145	400	75245	550	6911-03	800	6921-03	1000	6430203	1200
75143	400	75243	550	6911-03	800	6921-03	1000	6430203	1200
75137	400	75237	550	6911-03	800	6921-03	1000	6430203	1200
75111	400	75211	550	6911-03	800	6921-03	1000	6430203	1200
75146	400	75246	550	6911-03	800	6921-03	1000	6430203	1200
75145	400	75245	550	6911-03	800	6921-03	1000	6430203	1200
75115	375	75215	500	6913-03	800	6923-03	1000	6430203	1200
75145	400	75245	550	6911-03	800	6921-03	1000	6430203	1200
75143	400	75243	550	6911-03	800	6921-03	1000	6430203	1200

Footnotes:

- 3. For Original Street Pro Flywheel Counterweight Kit 560222 Must Be Ordered
- 14. 11" Pressure Plate used to replace 10.5"
- 15. 12" Pressure Plate used to replace 11"
- 16. Requires large bore master cylinder. Minimum 13/16 bore.
- 17. May require McLeod Internal HYD Bearing

PERFORMANCE STREET GUIDE

Custom Street Twin Application Guide

Year	Engine	Model	Vehicle Option	Spline	Ring Gear	Weight Kit Required	Assembly with Steel Flywheel	Assembly with Aluminum Flywheel	B&B Assembly with Steel Flywheel	B&B Assembly with Aluminum Flywheel
GM										
1986-1992	305 & 350	Passenger Car	1 Piece Seal & 0 Balance	1-1/8" x 10	153		6400404	6300404	64004B04	63004B04
1986-1992	305 & 350	Passenger Car	1 Piece Seal & 0 Balance	1-1/8" x 26	153		6400407	6300407	64004B07	63004B07
1993-1997	350	Camaro & Firebird	LT1 1985 and Down Crank & 0 Balance	1-1/8" x 26	153		6403207	6303207	N/A	N/A
1993-1997	350	Camaro & Firebird	LT1 1985 and Down Crank & 400 Counterbalance	1-1/8" x 26	153	560222	6403207	6303207	N/A	N/A
1993-1997	350	Camaro & Firebird	LT1 1985 and Down Crank & 1970-1990 454 Counterbalance	1-1/8" x 26	153	560222	6403207	6303207	N/A	N/A
1993-1997	350	Camaro & Firebird	LT1 1985 and Down Crank & 1991 and up 454 Counterbalance	1-1/8" x 26	153	560222	6403207	6303207	N/A	N/A
1993-1997	350	Camaro & Firebird	LT1 1985 and Down Crank & 502 Counterbalance	1-1/8" x 26	153	560222	6403207	6303207	N/A	N/A
1989-1996	350	Corvette	L98 & LT1 1985 and Down Crank & 0 Balance	1-1/8" x 26	153		6403307	6303307	N/A	N/A
1989-1996	350	Corvette	L98 & LT1 1985 and Down Crank & 400 Counterbalance	1-1/8" x 26	153	560222	6403307	6303307	N/A	N/A
1989-1996	350	Corvette	L98 & LT1 1985 and Down Crank & 1970-1990 454 Counterbalance	1-1/8" x 26	153	560222	6403307	6303307	N/A	N/A
1989-1996	350	Corvette	L98 & LT1 1985 and Down Crank & 1991 and up 454 Counterbalance	1-1/8" x 26	153	560222	6403307	6303307	N/A	N/A
1989-1996	350	Corvette	L98 & LT1 1985 and Down Crank & 1991 and 502 Counterbalance	1-1/8" x 26	153	560222	6403307	6303307	N/A	N/A
1986-1992	383 Stroker		Scat/Eagle Crank With Counterbalance & 1 Piece Seal	1-1/8" x 10	153	560222	6400404	6300404	64004B04	63004B04
1986-1992	383 Stroker		Scat/Eagle Crank With Counterbalance & 1 Piece Seal	1-1/8" x 26	153	560222	6400407	6300407	64004B07	63004B07
1965 and up	383, 400, 402, 454, 502	All Models	0 Balance	1-1/8" x 10	153		6400304	6300304	64003B04	63003B07
1965 and up	383, 400, 402, 454, 502	All Models	0 Balance	1-1/8" x 26	153		6400307	6300307	64004B07	63004B07
1991 and up	502	Crate Motor	With Counterbalance	1-1/8" x 10	153	560222	6400304	6300304	64003B04	63003B04
1991 and up	502	Crate Motor	With Counterbalance	1-1/8" x 26	153	560222	6400307	6300307	64004B07	63004B07

For Footnote references, please see page 54.

PERFORMANCE STREET GUIDE

Custom Street Twin Application Guide (cont)

Year	Engine	Model	Vehicle Option	Spline	Ring Gear	Weight Kit Required	Assembly with Steel Flywheel	Assembly with Aluminum Flywheel	B&B Assembly with Steel Flywheel	B&B Assembly with Aluminum Flywheel
2004 and up	572	620HP & 720HP Crate Motor	0 Balance	1-1/8" x 10	153		6400304	6300304	64003B04	63003B07
2004 and up	572	620HP & 720HP Crate Motor	0 Balance	1-1/8" x 26	153		6400307	6300307	64004B07	63004B07
1986-1991	305 & 350	Passenger Car	0 Balance and 1Piece Seal	1-1/8" x 10	168		6400204	6300204	64002B04	63002B04
1986-1991	305 & 350	Passenger Car	0 Balance and 1Piece Seal	1-1/8" x 26	168		6400207	6300207	64002B07	63002B07
1986-1992	383 Stroker		Scat/Eagle Crank With Counterbalance & 1 Piece Seal	1-1/8" x 10	168	560222	6400204	6400204	64002B04	63002B04
1986-1992	383 Stroker		Scat/Eagle Crank With Counterbalance & 1 Piece Seal	1-1/8" x 26	168	560222	6400207	6400207	64002B07	63002B07
1965 and up	383, 400, 402, 454, 502	All Models	0 Balance	1-1/8" x 10	168		6400104	6300104	64001B04	63001B04
1965 and up	383, 400, 402, 454, 502	All Models	0 Balance	1-1/8" x 26	168		6400107	6300107	64001B07	64001B07
1991 and up	502	Crate Motor	With Counterbalance	1-1/8" x 10	168	560222	6400104	6300104	64001B04	63001B04
1991 and up	502	Crate Motor	With Counterbalance	1-1/8" x 26	168	560222	6400107	6300107	64001B07	64001B07
2004 and up	572	620HP & 720HP Crate Motor	0 Balance	1-1/8" x 10	168		6400104	6300104	64001B04	63001B04
2004 and up	572	620HP & 720HP Crate Motor	0 Balance	1-1/8" x 26	168		6400107	6300107	64001B07	64001B07
Ford										
1963-1979	289, 302, 351		Small Flywheel, Mechanical Linkage & 0 Balance	1-1/16" x 10	157		6430103	6330103	64301B03	63301B03
1963-1979	289, 302, 351		Small Flywheel, Mechanical Linkage & 0 Balance	1-1/8" x 26	157		6430107	6330107	64301B07	63301B07
1963-1979	289, 302, 351		Small Flywheel, Mechanical Linkage & 28oz Counterbalance	1-1/8" x 26	157		6430107	6330107	64301B07	63301B07
1980-1995	302		Small Flywheel, Cable Linkage & 50oz Counterbalance (8)	1-1/8" x 26	157		6430107C	6330107C	N/A	N/A
1980-1995	302		Small Flywheel, Cable Linkage & 0 Balance (8)	1-1/16" x 10	157		6430103C	6330103C	N/A	N/A

PERFORMANCE STREET GUIDE

Custom Street Twin Application Guide (cont)

Year	Engine	Model	Vehicle Option	Spline	Ring Gear	Weight Kit Required	Assembly with Steel Flywheel	Assembly with Aluminum Flywheel	B&B Assembly with Steel Flywheel	B&B Assembly with Aluminum Flywheel
1980-1995	302		Small Flywheel, Cable Linkage & 0 Balance (8)	1-1/8" x 26	157		6430107C	6330107C	N/A	N/A
1963-1979	289, 302, 351		Large Flywheel, Mechanical Linkage & 0 Balance	1-1/16" x 10	164		6430203	6330203	64302B03	63302B03
1963-1979	289, 302, 351		Large Flywheel, Mechanical Linkage & 0 Balance	1-1/8" x 26	164		6430207	6330207	64302B07	63302B07
1963-1979	289, 302, 351		Large Flywheel, Cable Linkage & 0 Balance (8)	1-1/16" x 10	164		6430203C	6330203C	N/A	N/A
1963-1979	289, 302, 351		Large Flywheel, Cable Linkage & 0 Balance (8)	1-1/8" x 26	164		6430207C	6330207C	N/A	N/A
1968-1979	302 & 351	All Models	28oz Counterbalance	1-3/8" x 10	164		N/A	N/A	64302B06	63302B06
1968-1979	302 & 351	All Models	28oz Counterbalance	1-1/8" x 26	164		N/A	N/A	64302B07	64302B07
1968-1979	302 & 351		Large Flywheel, Cable Linkage & 28oz Counterbalance (8)	1-1/8" x 26	164		6430207C	6330207C	64302B07C	63302B07C
1980-1995	302		Large Flywheel, Cable Linkage & 50oz Counterbalance (8)	1-1/16" x 10	164		6430203C	6330203C	64302B03C	63302B03C
1980-1995	302		Large Flywheel, Cable Linkage & 50oz Counterbalance (8)	1-1/16" x 10	164		6430203C	6330203C	64302B03C	63302B03C
1971 and up	351	Pantera	Adjustable Throw Out Bearing Bridge & 0 Balance	1-1/16" x 10	164		6430203C	6330203C	64302B03C	63302B03C
1971 and up	351	Pantera	Adjustable Throw Out Bearing Bridge & 28oz Counterbalance	1-1/16" x 10	164		6430203C	6330203C	64302B03C	63302B03C

Special Note:

Use Diaphragm Street Twins For Most Applications.

All assemblies with "B" come with B&B Long Pressure Plate

"C" at the end of the assembly number means cable linkage comes with a throwout bearing and adjustable ball stud.

Footnotes:

1. Other splines for disc's are available that are not listed. Check with factory for splines needed.
2. Includes steel replacement master cylinder part No. 139001.
3. 1997-Up Corvette LS1 Motors come with 139000 steel master cylinders.
6. 1996-1998 2001.5 GT Mustangs have 6 bolt cranks. 1999-2000 GT has 8 bolt cranks. All 32V Cobra' s have 8 bolt cranks.
8. These assemblies come with a throwout bearing and adjustable ball stud.
10. When ordering counter balance weights for any Street Twin, purchase part No. for aluminum flywheels only.
12. When using a steel bellhousing/scattershield, you need an extended clutch fork so cable will clear bellhousing.
13. Twin assemblies for over 1200hp are available as special order (call factory for details).

NODULAR FLYWHEEL APPLICATION GUIDE

When replacing a clutch, the flywheel is one of the most overlooked parts. You have two choices: One is to resurface the flywheel and the other is to replace it.

McLeod's Nodular Iron Flywheels are a high quality yet low cost alternative to the hassles of resurfacing a flywheel.

Nodular Iron flywheels are stronger than the OEM and are direct bolt-in units.



Nodular Flywheel Application Guide

Nodular Flywheel Application Guide

Part Number	Application	Engine Balance	Clutch Patterns	O.E Number
450530	1997-2004 GM LS1 and LS6	Internal Balance	11' & 12"	GM 12554130N
450300	1955-1985 GM 305,307,327,350,427	Internal Balance	10.4"	GM14085720 & GM 3991406
450360	1986-1992 SB Chevy 305 and 350	Internal Balance	10.4"	GM 14088646
453100	1982-1995 Ford Mustang 5.0L	External Balance - 50 oz.	10" or 10.5"	Ford E2ZZ-6375A & E6ZZ-6375A

FLYWHEEL APPLICATION GUIDE

Flywheel Application Guide

Make/Model	Engine	Year	Notes	Bal-ance	Ring Gear	Ring Gear O.D.	Clutch Patterns	Weight Kit Required	Steel 22-27 LB.	Steel 28-33 LB.	Steel 34-40 LB.	Aluminum W/Steel Insert	
ASTON-MARTIN													
Vanquish	12 Cylinder	2001-Up	8 Bolt Crank	Neutral	164	14.215"	6,7,11, 12,15		463408			563408	
CHEVROLET													
All	Stock Applications					Stock Applications							
	6 Cylinder												
	225,231, 252, 300	1964-1987	Flat Flywheel	EXT	160	13.420"	3,4			465200		565200	
	231	1975-1977	Recessed Flywheel, Odd Fire	EXT	160	13.420"	3			467000		567000	
	231		Flat Flywheel, Even Fire	EXT	160s	13.420"	3,4			467100		567100	
	194, 230, 250	1960-1978	7/16 Crank Bolts	Neutral	168	14.096"	4,5,7			460130		560130 [9]	
	235, 261	1955-1982	7/16 Crank Bolts, 2nd Pro-duction	Neutral	168	14.096"	4,5,7			460130		560130 [9]	
	4.3L 262	1985-Up		Neutral	168	14.096"	4,5,7			460130		560130 [9]	
	4.8L 292	1962-1969	7/16 Crank Bolts	Neutral	168	14.096"	4,5,7		460122	460130	460140	560130 [9]	
	4.8L 292	1970	1/2" Crank Bolts	Neutral	168	14.096"	4,5,7			460136		560136	
	Chevrolet/ GMC Truck	5.0L 302	1955-1962	1/2" Crank Bolts	Neutral	168	14.096"	4,5,7			460138		560138
		1955-DWN	1st Production. 2.095" Reg-ister	Neutral	168	14.096"	4,5,7				460139		560139
	8 Cylinder												
		265 to 350	1955-1985		Neutral	168	14.096"	4,5,7			460130	460140	560130 [9]
		5.7L 350	1967-1985		Neutral	153	12.835"	4,6		460320	460300	460340	560300
	5.7L 350	1986-1992	Car With 1 Pc Seal	EXT	153	12.835"	4,6	560222		460360		560360	
	5.7L 350	1997-Up	LS Motors With Flat 6 Bolt Crank	Neutral	168	14.096"	5,13			460530		560530	
	396 to 427	1965-Up		Neutral	168	14.096"	4,5,7			460130	460140	560130 [9]	
	396 to 427	1965-Up	Big Block	Neutral	153	12.835"	4,6		460320	460300	460340	560300	
	7.4L 454	1970-1990		EXT	168	14.096"	4,5,7	560222		460130	460140	560130 [9]	
	7.4L 454	1991-Up		EXT	168	14.096"	4,5,7	560222		460130		560130 [9]	
Camaro	5.7L 350	1993-1997	LT1 With Pull Style Clutch	EXT	153	12.835"	4	560222	460350			560350	
Corvette	5.7L 350	1989-1996	LT1/L98 Replaces Dual Mass Flywheel W/Rigid Flywheel	EXT	153	12.835"	4	560222		460376		560376	
	5.7L 350	1990-1995	LT5 Replaces Stock Flywheel	Neutral	153	12.835"	4			460377		560377	
Passenger Car	5.0L 305	1963-1985	With 1 Pc Seal	EXT	153	12.835"	4,6	560222	460320	460300	460340	560300	
	5.4L 327	1963-1985		Neutral	153	12.835"	4,6		460320	460300	460340	560300	
Chevrolet/ GMC Truck	4.8L 294	2000-Up	With 12" Heatshield .400" add to face of flywheel	Neutral	168	14.096"	5,13			460535		560535	
	5.0L 305	1986-1999	1 Pc Seal With 11" Heatshield	EXT	168	14.096"	4,5,7	560222		460260		560260 [12]	
	5.0L 305	1986-1999	1 Pc Seal With 12" Heatshield	EXT	168	14.096"	4,5,7	560222		460260		560260	
	5.3L 323	2000-Up	With 12" Heatshield	Neutral	168	14.096"	5,13			460535		460535	
	5.7L 350	1986-1999	1 Pc Seal With 11" Heatshield	EXT	168	14.096"	4,5,7	560222		460260		560260 [12]	
	5.7L 350	1986-1999	1 Pc Seal With 12" Heatshield	EXT	168	14.096"	4,5,7	560222		460260		560260	
Custom Applications													
All	265 to 427	1955-1985	12" Steel Insert	Neutral	168	14.096"	4,5,7,20			460130	460140	560135	
	265 to 427	1955-1985	3/8" Long Clutch Pattern	Neutral	168	14.096"	4,5,8,20		460122	460132	460142	560132 [13]	
	305 & 350	1986-1998	Trucks, 1 Pc Seal	Neutral	168	14.096"	4,5,7,20			460260		560260 [12]	
	5.7L 350	1996-Up	LS Engines, .200" Thicker Than Stock, With 12" H.S. Flat Wheel	Neutral	168	14.096"	5,13,20			460536		560536	
	5.7L 350	1997-Up	LS Engines, .400" Thicker Than Stock, With 12" H.S. Flat Wheel	Neutral	168	14.096"	5,13,20			460535		560535	
	6.3L 383	1970-1985		EXT	168	14.096"	4,5,7,20	560222		460130	460140	560130	
	6.0L	1999-2000	LQ4 +.400" additional crank offset.	EXT	168	14.096"	4,5,7,20		460537				
	6.2L	2009-2014	LSA 8 bolt crank. Retrofit flywheel when flat style flywheel is needed	EXT	168	14.096"	4,5,7,20		460538			560538	
	6.2L	2009-2013	LS9 9 bolt crank. Retrofit flywheel when flat style flywheel is needed	EXT	168	14.096"	4,5,7,20		460539			560539	

For Footnote and Clutch Pattern references, please see page 60.

FLYWHEEL APPLICATION GUIDE

Flywheel Application Guide (cont.)

Make/Model	Engine	Year	Notes	Balance	Ring Gear	Ring Gear O.D.	Clutch Patterns	Weight Kit Required	Steel 22-27 LB.	Steel 28-33 LB.	Steel 34-40 LB.	Aluminum W/Steel Insert
All	6.3L 383	1986-1992	Scat/Eagle Crank & 1 Pc Seal	EXT	168	14.096"	4,5,7	560222		460260		560260 [12]
	6.3L 383	1986-1992	Scat/Eagle Crank, 1 Pc Seal & 12" H.S.	EXT	168	14.096"	4,5,7	560222		460260		560265
	6.3L 383	1986-1992	Scat/Eagle Crank & 1 Pc Seal	EXT	153	12.835"	4,6	560222		460360		560360
	400	1970-1985		EXT	153	12.835"	4,6	560222		460300		560300
	7.4L 454	1970-1990	3/8" Long Clutch Pattern	EXT	168	14.096"	4,5,8	560222	460122	460132	460142	560132 [13]
	7.4L 454	1991-Up	3/8" Long Clutch Pattern	EXT	168	14.096"	4,5,8	560222	460122	460132	460142	560132 [13]
	7.4L 454	1970-1990		EXT	153	12.835"	4,6	560222		460300		560300
	7.4L 454	1991-Up		EXT	153	12.835"	4,6	560222		460300		560300
	8.3L 502	1991-Up	With Crate Motor	EXT	168	14.096"	4,5,7	560222	460122	460130	460140	560130 [9]
	8.3L 502	1991-Up	Crate Motor, 3/8" Long Clutch Pattern	EXT	168	14.096"	4,5,8	560222	460122	460132	460142	560132 [13]
	8.3L 502	1991-Up		EXT	153	12.835"	4,6			460300		560300
	9.4L 572	2004-Up	620HP & 720HP Crate Motors & 12" H.S.	Neutral	168	14.096"	4,5,7		460122	460130	460140	560135
	9.4L 572	2004-Up	620HP & 720HP Crate Motors	Neutral	153	12.835"	4,6		460320	460300	460340	560300
LS-9	2009-Up	Retro Fit For Cars Needing Flat Flywheel, 9 Bolt Crank	Neutral	168	14.096"	4,5,7			460539		560539 [20]	
Camaro	350	1993-1997	Camaro LT1 with Pull Style Clutch	Neutral	153	12.835"	4		460376			560376
	400 Counterbalance	1993-1997	With 1985 and Down Crank & Pull Style Clutch	EXT	153	12.835"	4	560222		460370		560370
	454 Counterbalance 1970-1990	1993-1997	With 1985 and Down Crank & Pull Style Clutch	EXT	153	12.835"	4	560222		460370		560370
	454 Counterbalance 1991 and up	1993-1997	With 1985 and Down Crank & Pull Style Clutch	EXT	153	12.835"	4	560222		460370		560370
502 Counterbalance	1993-1997	With 1985 and Down Crank & Pull Style Clutch	EXT	153	12.835"	4	560222		460370		560370	
Corvette	350	1989-1996	LT1 & L98 With 1985 and Down Crank & Pull Style Clutch	Neutral	153	12.835"	4			460376		560373
	400 Counterbalance	1989-1996	LT1 & L98 With 1985 and Down Crank & Pull Style Clutch	EXT	153	12.835"	4	560222		460376		560373
	454 Counterbalance 1970-1990	1989-1996	LT1 & L98 With 1985 and Down Crank & Pull Style Clutch	EXT	153	12.835"	4	560222		460376		560373
	454 Counterbalance 1991 and up	1989-1996	LT1 & L98 With 1985 and Down Crank & Pull Style Clutch	EXT	153	12.835"	4	560222		460376		560373
	502 Counterbalance	1989-1996	LT1 & L98 With 1985 and Down Crank & Pull Style Clutch	EXT	153	12.835"	4	560222		460376		560373
	383	1989-1996	Corvette With Scat Crank & Pull Style Clutch	EXT	153	12.835"	4	560222		460376		560376
	350	1989-1996	LT5 With 1985 and Down Crank & Pull Style Clutch	Neutral	153	12.835"	4			460374		560374
	400 Counterbalance	1989-1996	LT5 With 1985 and Down Crank & Pull Style Clutch	EXT	153	12.835"	4	560222		460374		560374
	454 Counterbalance 1970-1990	1989-1996	LT5 With 1985 and Down Crank & Pull Style Clutch	EXT	153	12.835"	4	560222		460374		560374
	454 Counterbalance 1991 and up	1989-1996	LT5 With 1985 and Down Crank & Pull Style Clutch	EXT	153	12.835"	4	560222		460374		560374
502 Counterbalance	1989-1996	LT5 With 1985 and Down Crank & Pull Style Clutch	EXT	153	12.835"	4	560222		460374		560374	
Passenger Car	305 & 350	1986-1992	1 Pc Seal	Neutral	153	12.835"	4,6			460360		560360

For Footnote and Clutch Pattern references, please see page 60.

FLYWHEEL APPLICATION GUIDE

Flywheel Application Guide (cont.)

Make/Model	Engine	Year	Notes	Bal-ance	Ring Gear	Ring Gear O.D.	Clutch Patterns	Weight Kit Required	Steel 22-27 LB.	Steel 28-33 LB.	Steel 34-40 LB.	Aluminum W/Steel Insert
Chrysler-Dodge-Plymouth												
All	Stock Applications					Stock Applications						
	6 Cylinder											
	225	1960-1987		Neutral	122	12.276"	3,14		464001			
Truck	225	1960-1987	With 6 Bolt Crank	Neutral	130	13.195"	4,6		464122 [5]	464102		564102
All	8 Cylinder											
	318,340	1964-1999	6 Bolt Crank	Neutral	130	13.195"	4,6		464122 [5]	464102		564102
	318, 340	1964-1999	Small Flywheel With 6 Bolt Crank	Neutral	143	14.568"	4,5,8				464202	564202
	340	1972-1973	Small Flywheel With Cast 6 Bolt Crank	EXT	130	13.195"	4,6	564111		464102		564102
	331,354,392	1957-1961	Hemi 8 Bolt With Small Crank Bolts [11]	Neutral	172	14.640"	4,5,8				464300	564300
	360	1968-1977	Small Flywheel, 6 Bolt Crank	EXT	130	13.195"	4,6	564111		464102		564102
	5.7L 348	2002-2006	Hemi 8 With Bolt Crank	Neutral	143	14.568"	4,5,8			464208		564208
	6.1L 372	2008-2010	Hemi With 8 Bolt Crank	Neutral	131							
	6.1L 372	2006-Up	Hemi SRT Models with 8 Bolt Crank	Neutral	143	14.568"	4,5,8			464208		564208
	383, 400	1970-1971	With Cast 6 Bolt Crank	EXT	130	13.195"	4,6	564111		464102		564102
	383, 400, 440	1964-1978	Small Flywheel With 6 Bolt Crank	Neutral	130	13.195"	4,6			464102		564102
	383, 440	1958-1978	Large Flywheel With 6 Bolt Crank	Neutral	143	14.568"	4,5,8				464202	564202
	440	1970-1972	With 4BBL & 6BBL With 6 Bolt Crank	EXT	130	13.195"	4,6	564111		464102		564102
	440	1973-1978	Small Flywheel With Cast 6 Bolt Crank	EXT	130	13.195"	4,6	564111		464102		564102
	426	1963-1972	Wedge & Hemi, Small Flywheel With 8 Bolt Crank	Neutral	130	13.195"	4,6			464100		564100
	426	1966-1969	Wedge & Hemi Large Flywheel With 8 Bolt	Neutral	143	14.568"	4,5,8				464200	564200
	426	1966-1969	Street Hemi Large Flywheel With 8 Bolt Crank [11]	Neutral	172	14.640"	4,5,8				464308	564308
	440	1970-1972	With 4BBL & 6BBL With 6 Bolt Crank	EXT	143	14.568"	4,5,8	564111			464202	564202
	440	1973-1978	Large Flywheel With Cast 6 Bolt Crank	EXT	143	14.568"	4,5,8	564111			464202	564202
	Custom Applications											
	5.7L, 6.1L	2002-2007	Hemi With 8 Bolt Crank	Neutral	130	13.195"	4,6,20			464108		564108
	360	1994-1999	Magnum Small Flywheel Without Crank Trigger	EXT	130	13.195"	4,6,20	564111		464102		564102
	360	1968-2000	Large Flywheel With 6 Bolt Crank	EXT	143	14.568"	4,5,8,20	564111			464202	564202
	360	1994-2000	Magnum Large Flywheel Without Crank Trigger	EXT	143	14.568"	4,5,8,20	564111			464202	564202
	383,400	1970-1971	With Cast 6 Bolt Crank	EXT	143	14.568"	4,5,8,20	564111			464202	564202
	402	2002-2006	Magnum Crate Motor	EXT	130	13.195"	4,6,20	564111		464102		564102
	Ford - Mercury											
All	Stock Applications					Stock Applications						
	6 Cylinder											
	2.0L & 2.3L	1971-1974	Dual Crank Crank Patterns	Neutral	135	11.293"	2,14		463002			563002
	170, 200	1967-1970	Flat Flywheel (Special Order)	Neutral	136	11.798"	14		463020			563020
	240,300	1965-1999	Straight 6 Cylinder	Neutral	164	14.215"	6,11,12		463201	463200		563200
3.8L	1989-1997	With 11.5" Steel Insert	Neutral	164	14.215"	15		463203			563203	
Focus	2.0L	2002-2003	W/O Crank Trigger SOHC & DOHC	Neutral	135	11.293"	17		463015			563015

For Footnote and Clutch Pattern references, please see page 60.

FLYWHEEL APPLICATION GUIDE

Flywheel Application Guide (cont.)

Make/Model	Engine	Year	Notes	Bal-ance	Ring Gear	Ring Gear O.D.	Clutch Patterns	Weight Kit Required	Steel 22-27 LB.	Steel 28-33 LB.	Steel 34-40 LB.	Aluminum W/Steel Insert	
8 Cylinder													
All	Flathead	1948-Down		Neutral	112	14.126	4,6			463301		563301	
	Flathead	1949-1953		Neutral	112	14.126	4,6			463300		563300	
	260-289	1964-1969	Small Diameter Flywheel, 28oz.	EXT	157	13.294"	4,6,12	563333	463100			563100	
	5.0L 302	1980-1995	Small Diameter Flywheel, 50oz.	EXT	157	13.294"	4,6,12	563333	463100			563100	
	289-302-351	1963-1979	Large Diameter Flywheel, 28oz.	EXT	164	14.125"	6,7,11,12	563333		463200		563200	
	322-427	1963-1974	Fe Big Block	Neutral	184	15.503"	7,9,11			463215	463215	563210	
	351M-400M	1977-1982	28 In. Oz.	EXT	180	15.512"	7,9,11	563333			463500	563500	
	429-460	1969-1978	Big Block	Neutral	176	15.520"	7,9,11	563333		463222	463220	563220	
Mustang	4.6L	1996-1998	GT With 6 Bolt Crank	Neutral	164	14.125"	7,11,12,15		463456			563406	
	4.6L	1990-2000	GT With 8 Bolt Crank	Neutral	164	14.125"	7,11,12,15		463458			563408	
	4.6L	1996-1999	Cobra With 8 Bolt Crank	Neutral	164	14.125"	7,11,12,15		463458			563408	
	4.6L	2000-Up	Cobra With 8 Bolt Crank [8]	Neutral	164	14.125"	7,11,12,15		463458			563408	
	4.6L	2000-2001.5	GT With 6 Bolt Crank	Neutral	164	14.125"	7,11,12,15		463456			563406	
	4.6L	2001.5-Up	GT	Neutral	164	14.125"	7,11,12,15					563406	
	5.0L	2011-2014		Neutral	164	14.125"			473458			573408	
Light Truck	460	1979-1999	Light Trucks 1/2 & 3/4 Ton, 28oz.	EXT	176	15.520"	7,9,11	563333		463222	463220	563220	
Heavy Duty Truck	460	1979-1999	Trucks H.D. 3/4 Ton Up, 28oz.	EXT	180	15.512"	9,10	563333			463230	563230	
Custom Applications													
All	260-289	1964-1969	Small Diameter Flywheel	Neutral	157	13.294"	4,6,12,20		463100			563100	
	289-302-351	1963-1979	Large Diameter Flywheel	Neutral	164	14.125"	6,7,11,12,20		463201	463200		563200	
	5.0L 302	1980-1995	Large Diameter Flywheel, 50oz.	EXT	164	14.215"	6,7,11,12,20	563333		463200		563200	
	4.6L, 5.4L	1996-2001.5	6 Bolt Crank With 11.5 Steel Insert	Neutral	164	14.215"	15,20		463456			563406	
	4.6L, 5.4L	1996-2001.5	8 Bolt Crank With 11.5 Steel Insert	Neutral	164	14.215"	15,20		463458			563408	
Trucks	460	1979-1999	Trucks H.D. 3/4 Ton Up, 28oz. Bal	EXT	180	15.512"	9,10,20	563333			463230	563230	
Jeep-Javelin-AMX													
6 Cylinder													
All	225,231	1965-1979	Odd Fire	EXT	160	13.420"	3,4,20			465200		565200	
	All 6 Cylinder	1968-1974	6 Cylinder, 4.500" Crank Register	Neutral	164	13.830"	3,4,20			465000		565000	
	All V8	1968-1984	Externally Balanced With Crank Register OD 4.500	EXT	164	13.830"	4,5,20			465100 [14]		565100 [14]	
	All V8	1968-1984	Externally Balanced With Crank Register OD 4.625	EXT	164	13.830"	4,5,20			465101 [14]		565101 [14]	
	6.1L 372	2006-Up	Grand Cherokee With Hemi SRT	Neutral	143	14.568"	4,5,8,20			464208		564208	
Oldsmobile													
6 Cylinder													
All	198 & 215	1961-1963	Aluminum Block	Neutral	156	13.075"	3,4,6,20			467050		567050	
	231	1977-1987	Flat Flywheel, Even Fire	EXT	160	13.420"	3,4,20			467100		567100	
	231	1975-1977	Recessed Flywheel Odd, Fire [10]	EXT	160	13.420"	3,20			467000		567000	
	225, 231, 300	1964-1987	Flat Flywheel, Odd Fire	EXT	160	13.420"	3,4,20			465200		565200	
	4.1L 252	1964-1975	Flat Flywheel, Even Fire	EXT	160	13.420"	3,4,20			465200		565200	
	8 Cylinder												
	260,307,350, 403,455	1964-1985		EXT	166	13.979"	4,5,7,20			461505		561505	
	305 & 350	1986-1992	1 Pc Seal	EXT	153	12.835"	4,6,20			460360		560360	
305 & 350	1986-1992	1 Pc Seal (Special Application)	Neutral	153	12.835"	4,6,20			460360		560360		
330, 400,425	1964-1967		EXT	166	13.979"	4,5,7,20			461504		561504		
400	1968-1970		EXT	166	13.979"	4,5,7,20			461505		561505		

For Footnote and Clutch Pattern references, please see page 60.

FLYWHEEL APPLICATION GUIDE

Flywheel Application Guide (cont.)

Make/Model	Engine	Year	Notes	Bal-ance	Ring Gear	Ring Gear O.D.	Clutch Patterns	Weight Kit Required	Steel 22-27 LB.	Steel 28-33 LB.	Steel 34-40 LB.	Aluminum W/Steel Insert
Pontiac												
Stock Applications						Stock Applications						
6 Cylinder												
231	1977-1987		Flat Flywheel, Even Fire	EXT	160	13.420"	3,4,20			467100		567100
231	1975-1977		Recessed Flywheel, Odd Fire [10]	EXT	160	13.420"	3,20			467000		56700
225,252,300	1964-1987		Flat Flywheel, Odd Fire	EXT	160	13.420"	3,4,20			465200		565200
8 Cylinder												
326,389,421	1961-1964		Large Passenger Cars	EXT	166	13.420"	4,5,7			462102		562102
305 & 350	1986-1992		1 Pc Seal	EXT	153	12.835"	4,6	560222		460360		560360
350	1993-1997		Firebird LT1 With Pull Clutch	EXT	153	12.835"	4	560222		460350		560350
350	1998-2002		LS1 Stock Replacement	Neutral	168	14.096"	5,13			460530		560530
Custom Applications										Custom Applications		
231	1964-1987		Flat Flywheel, Odd Fire	EXT	160	13.420"	3,4,20			465200		565200
350	1993-1997		Firebird LT1 With Pull Style Clutch	Neutral	153	12.835"	4,20			460350		560350
305 & 350	1986-1992		1 Pc Seal	Neutral	153	12.835"	4,6,20			460360		560360
350	1998-2002		LS Engines, .200" Thicker Than Stock, With 12" H.S. Flat Flywheel	Neutral	168	14.096"	5,13,20			460536		560536
350	1998-2002		LS Engines, .400" Thicker Than Stock, With 12" H.S. Flat FlyWheel	Neutral	168	14.096"	5,13,20			460535		560535

C/B or W/CB = Counterbalance or With Counterbalance.
 HS = Heat shield or Steel Insert
 CT = Counter Trigger

Footnotes:

- [1] Not all flywheels listed are stocking items. Some numbers are special order.
- [2] Steel flywheel weights are an approximation and are not exact.
- [3] Ductile flywheels are approximately 16# and have an 11" surface with a 10.5" /10.95 bolt pattern.
- [4] 1997-down flywheels have a large registration for crank, remove choke ring in the back of crank of these flywheels.
- [5] 18.5 lbs. special for oval track.
- [7] Steel flywheel part NO. 463403 and 463409 are drilled with clutch pattern NO' s 12, 15.
- [8] These flywheels have a 6.750 crank recess I.D. for stock Valeo/Mustang disc clearance.
- [9] 11" steel insert only, will not accept 12" disc, use 560135 for 12" steel insert and counterbalance number for external balance.
- [10] You may use 465200 flat flywheel and put a 10.5" or 10.95" P/P and disc on it.
- [11] These flywheels use Bendix type starters.
- [12] 11" steel insert only, will not accept 12" disc, use 560265 for 12" steel insert and add counterbalance number for external balance.
- [13] 11" steel insert only, will not accept 12" disc, use 560137 for 12" steel insert and add counterbalance number for external balance.
- [14] These flywheels are drilled for external balance, bolt on counterbalance is in engineering at this printing.
- [15] These flywheels must use our starter NO. 810170 and must cut the block for clearance. [Instructions included]
- [20] Special order. Call for Availability.

Clutch Patterns

1. 8" Diaphragm
2. 8.5" Diaphragm
3. 9-1/8, 9-1/4, B&B-Diaphragm
4. 10, 10.5, 10.95" B&B-Diaphragm
5. 11, 12" B&B-Diaphragm-Shouldered Bolt
6. 10, 10.5" Long & 10" Diaphragm
7. 11" Long-Diaphragm With 5/16 Bolt Holes
8. 11" Long With 3/8 Bolt Holes

Clutch Patterns

9. 11.5, 12" Long-Diaphragm
10. 12" Long-8 Bolt Cover
11. 11" Diaphragm Ford Trucks Even Pattern
12. 10.5" Mustang Diaphragm 1986-2000 With Dowel Pin Pattern
13. 12" LS1 Diaphragm Metric Bolts With Dowel Pin Pattern
14. 9-1/16" Long Diaphragm
15. 11" Mustang With Dowel Pin Pattern & 11.5 Steel Insert
16. 12" Diaphragm 8 Bolt Cover Mopar Viper/Truck
17. 9" Diaphragm Focus

? Did You Know?

When Ford built the 2000 Mustang Cobra R and 2003-04 Mustang Cobra they came to McLeod for the billet Aluminum Flywheel.



McLeod Racing

? Did You Know?

The famed McLeod club was decided from playing cards. Founder Red Roberts used to play the card game hearts and during the early 70's there were other companies in the performance industry with logos such as a heart, spade and diamond. Red decided on the club because two clubs is better than one heart!!

STREET DISC BUYERS GUIDE

Street Disc Application Guide

O.D. & Splines	Disc Diameter	McLeod Splines Designation #	100 Series	400 Series	500 Series	600 Series	700 Series	900 Series
3/4" x 18 Spl	8.5"	#14	271413		271453	271463		271493
13/16" x 18 Spl	8.5"	#23	272311					272391
	9 1/18"		272315					272395
13/16" x 24 Spl	8.5"	#20	272016					272096
	9 11/16"		272017					272097
7/8" x 20 Spl	8.5"	#15	271512					271592
	9 11/16"		271515		271555	271565		271595
7/8" x 28 Spl	8.5"	#22	272215					272295
15/16" x 10 Spl	8.5"	#17	271712					271792
	10.5"		271710					271790
15/16" x 17 Spl	8.5"	#16	271612					271692
1" x 10 Spl	8.5"	#01	270119					
	9 11/16"		260117					260917
	10"		260116					260916
	10.5"		260110		260510	260610		260910
	11"		260111		260511	260611		260911
	12"		260113		260513	260613		260913
1" x 14 Spl	8.5"	#08	270817					270897
	9 1/18"		270815		270855	270865		270895
	9 11/16"		270811		270851	270861		270891
	10"		270816					270896
	10.5"		270810		270850	270860		270890
	11"		270814		270854	270864		270894
1" x 20 Spl	9 1/8"	#12	271214		271524	271264		271294
1" x 22 Spl	8.5"	#11	271112					271192
1" x 23 Spl American	8.5"	#02	260105					260905
	9 1/8"		260129		260529	260629		260929
	9 11/16"		260127		260527	260627		260927
	10"		260126					260926
	10.5"		260120	260420	260520	260620	260720	260920
	11"		260121		260521	260621	260721	260921
	12"		260123		260523	260623		260923
1" x 23 Spl Metric	9 1/8"	#25	272519		272559	272569		272599
	9 11/16"		272517		252557	272567		272597
	10"		262516		272556	272566		272596
	10.5"		272510	272540	272550	272560		272590
	11"		272511		272551	272561		272591
	12"		272513		272553	272563		272593

STREET DISC BUYERS GUIDE

Street Disc Application Guide (cont.)

O.D. & Spline	Disc Diameter	McLeod Spline Designation #	100 Series	400 Series	500 Series	600 Series	700 Series	900 Series
1" x 24 Spl	8.5"	#10	271012					271092
	9 1/8"		271014		271054	271064		271094
	9 11/16"		271016		271056	271066		271096
	10.5"		271010		271053	271063		271093
1 1/32" x 10 Spl	11"	#31	273117		273157	273167		273197
1 1/32" x 23 Spl	9 11/16"	#24	272417		272457	272467		272497
1 1/32" x 24 Spl	8.5"	#27	272712					272792
1 1/16" x 10 Spl	8.5"	#03	260103		260503	260603		260903
	9 1/8"		260134		260534	260634		260934
	10"		260134					260936
	10.5"		260130	260430	260530	260630	260730	260930
	11"		260131		260531	260631	260731	260931
	11.5"		260132					
	12"		260133		260533	260633		260933
1 1/18" x 10 Spl	8.5"	#04	260144					260944
	9 1/8"		260107		260507	260607		260907
	9 11/16"				260457	260647		260947
	10"		260146					260946
	10.5"		260140	260440	260540	260640	260740	260940
	11"		260141		260541	260641	260741	260941
	12"		260143		260543	260643		260943
1 1/8" x 21 Spl	10.5"	#09	270910		271050	271060		270990
1 1/8" x 26 Spl	8.5"	#07	260174					260974
	9 1/18"		260178		260578	260678		260978
	9 11/16"		260175		260575	260675		260975
	10"		260176					260976
	10.5"		260170	260470	260570	260670	260775	260970
	10.75"							260977
	11"		260171		260571	260671	260771	260971
	11.5"							
	12"		260173		260573	260673		260973
1 9/64" x 10 Spl	8.5"	#21	272114					272194
	10.5"		272110		272150	272160		272190
	11"		272111		272151	272161		272191
	12"		272113		272153	272163		272193

STREET DISC BUYERS GUIDE

Street Disc Application Guide (cont.)

O.D. & Spline	Disc Diameter	McLeod Spline Designation #	100 Series	400 Series	500 Series	600 Series	700 Series	900 Series
1 1/4" x 10 Spl	10.5"	#32	273210		273250	273260		273290
	11"		273211		273251	273261		273291
	12"		273213		273253	273263		273293
1 3/8" x 10 Spl	10"	#06	260166					260966
	10.5"		260160	260460	260560	260660	260760	260960
	11"		260161		260561	260661	260761	260961
	11.5"							
1 13/16" x 18 Spl	10.5"	#05	260150	260450	260550	260650	260750	260950
	11"		260151		260551	260651	260751	260951
	12"		260153		260553	260653		260953

Pilot Bushings/Bearings

Pilot Bushings/Bearings	Style	Size	Part Number
GM			
	Bushing	1.094" OD X .592" ID	8-1094-1
	Bearing - Needle Roller	1.094" OD X .592" ID	8605
	Bushing - Special Extended	1.094" OD X .592" ID	8-1094-4
Corvette - LS	Roller	1.700" OD X .592" ID X .510" L	8619
Pontiac	Bushing	1.380" OD X .592" ID	8-1380-1
Pontiac	Bearing	1.380" OD X .592" ID	8-1380-7
FORD			
Small Block	Bushing	1.380" OD X .592" ID	8-1380-1
Small Block	Bearing	1.380" OD X .592" ID	8-1380-7
Small Block	Bushing - Special Extended	1.380" OD X .592" ID	8-1380-4
Small Block	Bushing	1.380" OD X .672" ID	8-1380-2
Small Block	Bushing - Special Extended	1.380" OD X .672" ID	8-1380-5
Small Block	Bushing	1.380" OD X .750" ID	8-1380-3
Windsor 289/302/351	Bearing - Roller Pilot		8606
Modular 4.6/5.4L	Bearing - Roller Pilot		8606
Big Block	Bushing	1.850" OD X .592" ID	8-1850-1
Big Block	Bushing - Special Extended	1.850" OD X .592" ID	1-1850-4
Big Block	Bushing	1.850" OD X .672" ID	8-1850-2
Big Block	Bushing	1.850" OD X .750" ID	8-1850-3
MOPAR			
	Bushing	.941" OD X .750" ID X .875" L	8603
Adapter Style			
Gm To Ford Trans	Bushing	1.094" OD X .672" ID	8-1094-2
Gm To Mopar Trans	Bushing	1.094" OD X .750" ID	8-1094-3

Pressure Plate/Flywheel Bolts

Pressure Plate To Flywheel					
Part Number	Thread	Pitch	Qty. Per Pack	Torque Spec	
1500	3/8"	16	6	30-35 FT. LBS	No Lockwasher Needed
1501	5/16"	18	6	20-25 FT. LBS	
1502	3/8"	16	6	30-35 FT. LBS	GM LT Applications, 93-97
1505	10 mm	1.5 mm	6	35-40 FT. LBS	99- Up Mustang
1507	8 mm	1.25 mm	6	20-25 FT. LBS	86-99 Mustang
Flywheel To Crank					
Part Number	Thread	Pitch	Qty. Per Pack	Torque Spec	
GM					
1540	7/16"	20	6	60-65 FT. LBS	
1556	11mm	1.5 mm	6	85 FT . LBS	1997-2012 LS GEN III
1558	11mm	1.5 mm	8	85 FT . LBS	2009-2012 LS-A,LS-X
1559	11mm	1.5 mm	9	85 FT . LBS	2009-2012 LS9 GEN IV
FORD					
1540	7/16"	20	6	60-65 FT. LBS	
1566	10 mm	1.0 mm	6	70 FT. LBS	1996-2010 4.6L
1568	10 mm	1.0 mm	8	70 FT. LBS	1997-2012 4.6L/5.0L/5.4L
MOPAR					
1540	7/16"	20	6	60-65 FT. LBS	
1542	1/2"	20	8	70-75 FT. LBS	Hemi

Pilot Tools

Make	Diameter	Spline	Pilot Diameter	Part Number	Notes:
CUMMINS	1 3/8"	10	0.75"	105362	
GM	1 1/8"	10	0.59"	105301	
	1 1/8"	26	0.59"	105313	
	1 3/16"	18	0.59"	105382-GM	
FORD	1	23	0.67"	105111	Metric Spline
	1 1/16"	10	0.67"	105304	
	1 1/8"	26	0.67"	105313-F	
	1 3/8"	10	0.67"	105325	
MOPAR	1"	23	0.75"	105309	
	1 1/8"	26	0.75"	105313-M	
	1 3/8"	10	0.75"	105362	
	1 3/16"	18	0.75"	105382	
	1 1/4"	10	0.75"	105412	

RACING ASSEMBLIES

Soft Lok

The McLeod Soft-Lok assembly is the most widely used McLeod clutch assembly for drag racers, and is not recommended for street use. This unit is an NHRA & IHRA record holder.

Low Static Pressure for Light Pedal Effort and Soft Clutch Engagement

Leave The Starting Line Harder With Less Tire Spin

Enough Holding Power For The Entire Run

Adjustable Spring Pressure

Available With Counterweights



Kit includes Pressure Plate
Sintered Iron Disc
Aluminum Flywheel

Don Fezell's, McLeod equipped Mustang, makes history by being the first in The 8's in NHRA Stock Eliminator



Mag Force

We have now added optional adjustable stands to the Mag Force to give clutch tuners that added advantage. The pressure plate has been redesigned for added strength and we have made the diaphragm a bolt in design so it can be serviced at the track.

McLeod Racing's Mag Force clutch kit has long been considered the standard for racing clutches. With its new updates it is poised to hold that position for a very long time. This iconic has been the choice of road racers, drifters, salt flat racers and sport compact drag racing drivers for years. One reason is its versatility.

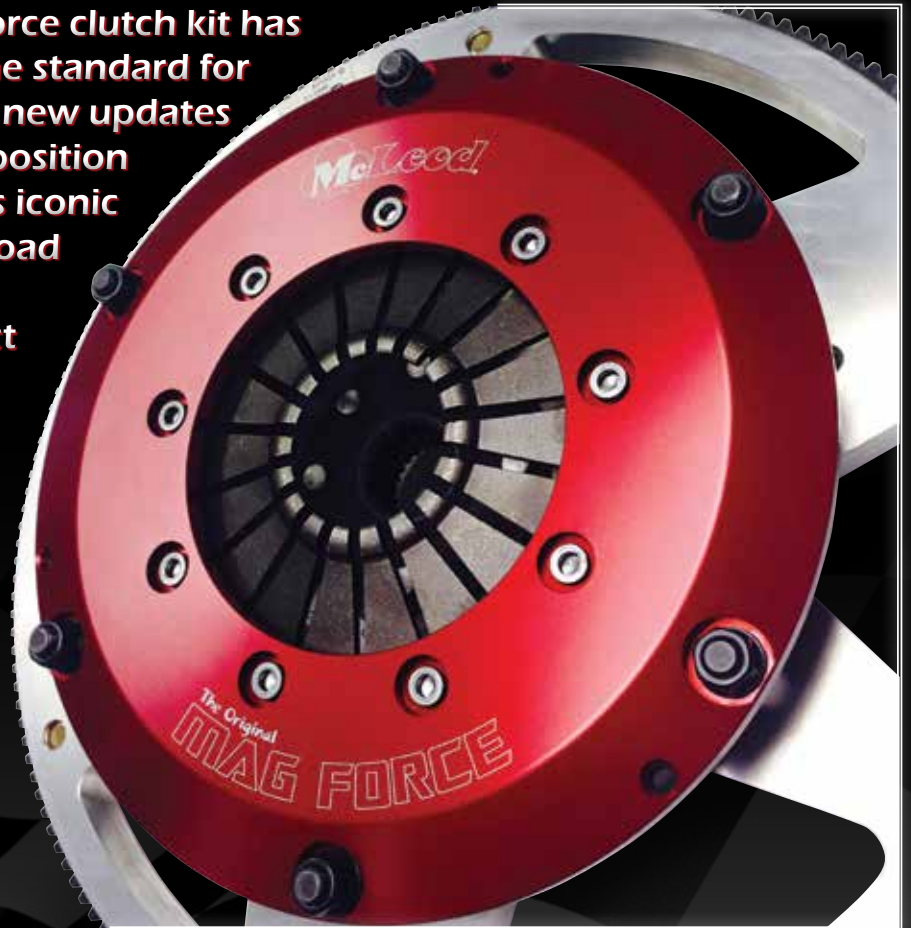

Racing Assemblies

Kit includes Performance Flywheel

Available In Single, Twin & Triple Configurations

Available In Strapped Version For Quiet & Clean Release

Available in Pin Drive Version For Quick Release

Available for domestic and sport compact applications

RACING ASSEMBLIES

Pro Series

McLeod Racing and Boninfante Friction have joined forces to create the ultimate 10" street/strip clutch for ultra-high horsepower cars. The Pro Series can handle 1000 to 3000 horsepower depending on the number of discs used.

Ideal for street use but can be used for drag racing also.

Available In Single, Twin and Triple Disc Configurations

CNC Machined From 6061 T6 Aluminum

Fully Adjustable Spring Pressure
Counterweighted Levers



Includes ARP Hardware & Pre-Set Height Gauge

Pull Truck

The 4400 Series clutch system from McLeod is ideal for truck puller and high horsepower sand drag applications. Recommended for non-shifting motorsport applications. Not intended for street use.

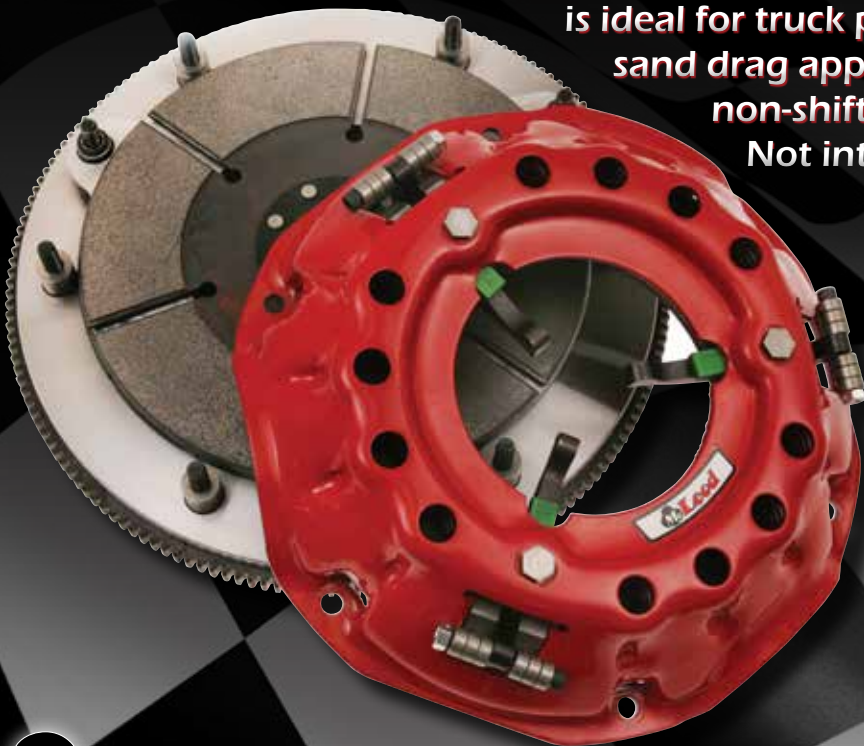

Borg & Beck Pressure Plate
With Counterweights

High RPM Lock Up Capacity

Includes Steel Flywheel and
Sintered Iron Discs

Includes Steel Flywheel and
Sintered Iron Discs

Line Launch

McLeod is proud to reintroduce its world famous Line Launch System. When thousandth's of a second can make all the difference, the Line Launch is your ace in the hole. The innovative Line Launch gives the driver the ability to control clutch release by simply letting go of a switch.

With the McLeod Line Launch you depress the clutch pedal to the desired position for release and then by activating a switch you lock the clutch in place. Simply let the switch go to release the clutch and launch the car for a quicker reaction time.

For cars equipped with an existing roll control device, McLeod's new Two Stage Switch is available. Using our Two Stage Switch in conjunction with the Line Launch and your existing roll control device, you can release both the brake and clutch at the same time.



See our Hydraulic Bearing sections for kits available with the Line Launch.

Line Launch Part Number 139510
2 Stage Switch Part Number 139021

RACE PRODUCT GUIDE

Soft Lok Application Guide

Make	Engine	Ring Gear	Balance	Spline	With 10" Disc	10.5" Disc	11" Disc
Chevrolet	55-85 V8	153	Neutral	1" x23	4916-00-02		
	55-85 V8	153	Neutral	1 1/8" x10	4916-00-04		
	55-85 V8	153	Neutral	1 3/16" x18	4916-00-05		
	55-85 V8	153	Neutral	1 3/8" x10	4916-00-06		
	55-85 V8	153	Neutral	1 1/8" x26	4916-00-07		
	55-85 V8	168	Neutral	1" x23		4910-00-02	4911-00-02
	55-85 V8	168	Neutral	1 1/8" x10		4910-00-04	4911-00-04
	55-85 V8	168	Neutral	1 3/16" x18		4910-00-05	4911-00-05
	55-85 V8	168	Neutral	1 3/8" x10		4910-00-06	4911-00-06
	55-85 V8	168	Neutral	1 1/8" x26		4910-00-07	4911-00-07
	86-92 350	153	Neutral	1" x23	4917-1A-02		
	86-92 350	153	External	1 1/8" x10	4917-1A-04		
	86-92 350	153	External	1 3/16" x18	4917-1A-05		
	86-92 350	153	External	1 3/8" x10	4917-1A-06		
	86-92 350	153	External	1 1/8" x26	4917-1A-07		
	86-92 350	168	External	1 1/8" x10		4912-1A-04	4913-1A-04
	86-92 350	168	External	1 3/16" x18		4912-1A-05	4913-1A-05
	86-92 350	168	External	1 3/8" x10		4912-1A-06	4913-1A-06
	86-92 350	168	External	1 1/8" x26		4912-1A-07	4913-1A-07
	383/400	153	External	1 1/8" x10	4916-2C-04		
	383/400	153	External	1 3/16" x18	4916-2C-05		
	383/400	153	External	1 3/8" x10	4916-2C-06		
	383/400	153	External	1 1/8" x26	4916-2C-07		
	383/400	168	External	1 1/8" x10		4910-2C-04	4911-2C-04
	383/400	168	External	1 3/16" x18		4910-2C-05	4911-2C-05
	383/400	168	External	1 3/8" x10		4910-2C-06	4911-2C-06
	383/400	168	External	1 1/8" x26		4910-2C-07	4911-2C-07
	70-90 454	153	External	1 1/8" x10	4916-3C-04		
	70-90 454	153	External	1 3/16" x18	4916-3C-05		
	70-90 454	153	External	1 3/8" x10	4916-3C-06		
	70-90 454	153	External	1 1/8" x26	4916-3C-07		
	70-90 454	168	External	1 1/8" x10		4910-3C-04	4911-3C-04
	70-90 454	168	External	1 3/16" x18		4910-3C-05	4911-3C-05
	70-90 454	168	External	1 3/8" x10		4910-3C-06	4911-3C-06
	70-90 454	168	External	1 1/8" x26		4910-3C-07	4911-3C-07
	91-00 454	153	External	1 1/8" x10	4916-4C-04		
	91-00 454	153	External	1 3/16" x18	4916-4C-05		
	91-00 454	153	External	1 3/8" x10	4916-4C-06		
	91-00 454	153	External	1 1/8" x26	4916-4C-07		
	91-00 454	168	External	1 1/8" x10		4910-4C-04	4911-4C-04
	91-00 454	168	External	1 3/16" x18		4910-4C-05	4911-4C-05
	91-00 454	168	External	1 3/8" x10		4910-4C-06	4911-4C-06
91-00 454	168	External	1 1/8" x26		4910-4C-07	4911-4C-07	
502	153	External	1 1/8" x10	4916-4A-04			

RACE PRODUCT GUIDE

Soft Lok Application Guide (cont)

Make	Engine	Ring Gear	Balance	Spline	With 10" Disc	10.5" Disc	11" Disc
Chevrolet	502	153	External	1 1/8" x26	4916-4A-07		
	502	168	External	1 1/8" x10		4910-4A-04	4911-4A-04
	502	168	External	1 1/8" x26		4910-4A-07	4911-4A-07
	98-UP LS	168	Neutral	1 1/8" x10		4914-00-04	4915-00-04
	98-UP LS	168	Neutral	1 3/16" x18		4914-00-05	4915-00-05
	98-UP LS	168	Neutral	1 3/8" x10		4914-00-06	4915-00-06
	98-UP LS	168	Neutral	1 1/8" x26		4914-00-07	4915-00-07
Ford	289, 302	157 (1)	Neutral	1 1/16" x10	4960-00-03		
	289, 302	157 (1)	Neutral	1 3/16" x18	4960-00-05		
	289, 302	157 (1)	Neutral	1 3/8" x10	4960-00-06		
	289, 302	157 (1)	Neutral	1 1/8" x26	4960-00-07		
	260, 289	157 (1)	28 oz	1 1/16" x10	4960-28-03		
	260, 289	157 (1)	28 oz	1 3/16" x18	4960-28-05		
	260, 289	157 (1)	28 oz	1 3/8" x10	4960-28-06		
	260, 289	157 (1)	28 oz	1 1/8" x26	4960-28-07		
	302	157 (1)	50 oz	1 1/16" x10	4960-50-03		
	302	157 (1)	50 oz	1 3/16" x18	4960-50-05		
	302	157 (1)	50 oz	1 3/8" x10	4960-50-06		
	302	157 (1)	50 oz	1 1/8" x26	4960-50-07		
	302-351	164 (1)	Neutral	1 1/16" x10		4969-00-03	4970-00-03
		164 (1)	Neutral	1 3/16" x18		4969-00-05	4970-00-05
		164 (1)	Neutral	1 3/8" x10		4969-00-06	4970-00-06
		164 (1)	Neutral	1 1/8" x26		4969-00-07	4970-00-07
	302-351	164 (1)	28 oz	1 1/16" x10		4969-28-03	4970-28-03
	302-351	164 (1)	28 oz	1 3/16" x18		4969-28-05	4970-28-05
	302-351	164 (1)	28 oz	1 3/8" x10		4969-28-06	4970-28-06
	302-351	164 (1)	28 oz	1 1/8" x26		4969-28-07	4970-28-07
Small Block	164 (1)	50 oz	1 1/16" x10		4969-50-03	4970-50-03	
Small Block	164 (1)	50 oz	1 3/16" x18		4969-50-05	4970-50-05	
Small Block	164 (1)	50 oz	1 3/8" x10		4969-50-06	4970-50-06	
Small Block	164 (1)	50 oz	1 1/8" x26		4969-50-07	4970-50-07	
Ford	4.6/5.4 6 Bolt Crank	164 (1)	Neutral	1 1/16" x10		4966-00-03	4976-00-03
	4.6/5.4 6 Bolt Crank	164 (1)	Neutral	1 3/16" x18		4966-00-05	4976-00-05
	4.6/5.4 6 Bolt Crank	164 (1)	Neutral	1 3/8" x10		4966-00-06	4976-00-06
	4.6/5.4 6 Bolt Crank	164 (1)	Neutral	1 1/8" x26		4966-00-07	4976-00-07
	4.6/5.4 8 Bolt Crank	164 (1)	Neutral	1 1/16" x10		4968-00-03	4978-00-03
	4.6/5.4 8 Bolt Crank	164 (1)	Neutral	1 3/16" x18		4968-00-05	4978-00-05
	4.6/5.4 8 Bolt Crank	164 (1)	Neutral	1 3/8" x10		4968-00-06	4978-00-06

RACE PRODUCT GUIDE

Soft Lok Application Guide (cont)

Make	Engine	Ring Gear	Balance	Spline	With 10" Disc	10.5" Disc	11" Disc
Ford	4.6/5.4 8 Bolt Crank	164 (1)	Neutral	1 1/8" x26		4968-00-07	4978-00-07
	332 THRU 428 Fe	184	Neutral	1 1/16" x10		4979-00-03	4980-00-03
	332 THRU 428 Fe	184	Neutral	1 3/16" x18		4979-00-05	4980-00-05
	332 THRU 428 Fe	184	Neutral	1 3/8" x10		4979-00-06	4980-00-06
	332 THRU 428 Fe	184	Neutral	1 1/8" x26		4979-00-07	4980-00-07
	428 Fe	184	28 oz	1 1/16" x10		4979-28-03	4980-28-03
	428 Fe	184	28 oz	1 3/16" x18		4979-28-05	4980-28-05
	428 Fe	184	28 oz	1 3/8" x10		4979-28-06	4980-28-06
	428 Fe	184	28 oz	1 1/8" x26		4979-28-07	4980-28-07
	429-460 Up To 1978	176	Neutral	1 1/16" x10		4993-00-03	4994-00-03
	429-460 Up To 1978	176	Neutral	1 3/16" x18		4993-00-05	4994-00-05
	429-460 Up To 1978	176	Neutral	1 3/8" x10		4993-00-06	4994-00-06
	429-460 Up To 1978	176	Neutral	1 1/8" x26		4993-00-07	4993-00-07
	429-460 Up To 1979	176	28 oz	1 1/16" x10		4993-28-03	4994-28-03
	429-460 Up To 1979	176	28 oz	1 3/16" x18		4993-28-05	4994-28-05
	429-460 Up To 1979	176	28 oz	1 3/8" x10		4993-28-06	4994-28-06
	429-460 Up To 1979	176	28 oz	1 1/8" x26		4993-28-07	4994-28-07
MOPAR	6 Bolt Crank	130	Neutral	1" x23	4956-00-02		
	6 Bolt Crank	130	Neutral	1 3/16" x18	4956-00-05		
	6 Bolt Crank	130	Neutral	1 3/8" x10	4956-00-06		
	6 Bolt Crank	130	Neutral	1 1/8" x26	4956-00-07		
	8 Bolt Crank	130	Neutral	1" x23	4958-00-02		
	8 Bolt Crank	130	Neutral	1 3/16" x18	4958-00-05		
	8 Bolt Crank	130	Neutral	1 3/8" x10	4958-00-06		
	8 Bolt Crank	130	Neutral	1 1/8" x26	4958-00-07		
	6 Bolt Crank	143	Neutral	1" x23		4952-00-02	4953-00-02
	6 Bolt Crank	143	Neutral	1 3/16" x18		4952-00-05	4953-00-05
	6 Bolt Crank	143	Neutral	1 3/8" x10		4952-00-06	4953-00-06
	6 Bolt Crank	143	Neutral	1 1/8" x26		4952-00-07	4953-00-07
	8 Bolt Crank	143	Neutral	1" x23		4948-00-02	4949-00-02
	8 Bolt Crank	143	Neutral	1 3/16" x18		4948-00-05	4949-00-05
	8 Bolt Crank	143	Neutral	1 3/8" x10		4948-00-06	4949-00-06
8 Bolt Crank	143	Neutral	1 1/8" x26		4948-00-07	4949-00-07	

RACE PRODUCT GUIDE

Soft Lok Replacement Parts

Pressure Plates				
	10"	10.5"	11"	
	360440	360540	360550	
	Spline	10"	10.5"	
	1" x 23	5007-02	5008-02	
	1 1/16" x 10	5007-03	5008-03	
	1 1/8" x 10	5007-04	5008-04	
	1 3/16" x 18	5007-05	5008-05	
	1 3/8" x 10	5007-06	5008-06	
	1 1/8" x 26	5007-07	5008-07	
	Spline	10"	10.5"	11"
	1" x 23	5007J-02	5008J-02	5009-02
	1 1/16" x 10	5007J-03	5008J-03	5009-03
	1 1/8" x 10	5007J-04	5008J-04	5009-04
	1 3/16" x 18	5007J-05	5008J-05	5009-05
	1 3/8" x 10	5007J-06	5008J-06	5009-06
	1 1/8" x 26	5007J-07	5008J-07	5009-07
	1" x 23	D20300-02	D20300-02	D20300-02
	1 1/16" x 10	D20300-03	D20300-03	D20300-03
	1 1/8" x 10	D20300-04	D20300-04	D20300-04
	1 3/16" x 18	D20300-05	D20300-05	D20300-05
	1 3/8" x 10	D20300-06	D20300-06	D20300-06
	1 1/8" x 26	D20300-07	D20300-07	D20300-07
HUB RIVETS (each) 16 Required	D20581	D20581	D20581	
LEVERS 3 Required	P31007	P31007	P31007	
YOKES 3 Required	P30964	P30964	P30964	
YOKE BUSHINGS 3 Required	P30661	P30661	P30661	
CASTING BUSHINGS 3 Required	P31101	P31101	P31101	
PRESSURE RING	P31335	P31345	P31355	
HEAT SHIELD	504100-24	504105-30	504110-27	
P/P COVER	P30140-1R	P30155R	P30155R	
SPRINGS 9 Required	P10304	P10304	P10304	
SPRING ADJUSTER 6 Required	P30054	P30054	P30054	
ADJUSTER BOLT 6 Required	P30056	P30056	P30056	

RACE PRODUCT GUIDE

Mag Force - Strapped Application Guide

Make	Engine	Ring Gear	Balance	Spline	Single Disc 500 FT LBS	Two Discs 900 FT LBS
Chevrolet	55-85 V8	105	Neutral	1 1/8" x10	653011-00-04	653012-00-04
	55-85 V8	105	Neutral	1 3/16" x18	653011-00-05	653012-00-05
	55-85 V8	105	Neutral	1 1/8" x26	653011-00-07	653012-00-07
	55-85 V8	153	Neutral	1 1/8" x10	653001-00-04	653002-00-04
	55-85 V8	153	Neutral	1 3/16" x18	653001-00-05	653002-00-05
	55-85 V8	153	Neutral	1 1/8" x26	653001-00-07	653002-00-07
	55-85 V8	168	Neutral	1 1/8" x10	653021-00-04	653022-00-04
	55-85 V8	168	Neutral	1 3/16" x18	653021-00-05	653022-00-05
	55-85 V8	168	Neutral	1 1/8" x26	653021-00-07	653022-00-07
	86-92 350	153	External	1 1/8" x10	653031-1A-04	653032-1A-04
	86-92 350	153	External	1 3/16" x18	653031-1A-05	653032-1A-05
	86-92 350	153	External	1 1/8" x26	653031-1A-07	653032-1A-07
	86-92 350	168	External	1 1/8" x10	653031-1A-04	653032-1A-04
	86-92 350	168	External	1 3/16" x18	653031-1A-05	653032-1A-05
	86-92 350	168	External	1 1/8" x26	653031-1A-07	653032-1A-07
	383/400	153	External	1 1/8" x10	653001-2C-04	653002-2C-04
	383/400	153	External	1 3/16" x18	653001-2C-05	653002-2C-05
	383/400	153	External	1 1/8" x26	653001-2C-07	653002-2C-07
	383/400	168	External	1 1/8" x10	653021-2C-04	653022-2C-04
	383/400	168	External	1 3/16" x18	653021-2C-05	653022-2C-05
	383/400	168	External	1 1/8" x26	653021-2C-07	653022-2C-07
	70-90 454	153	External	1 1/8" x10	653001-3C-04	653002-3C-04
	70-90 454	153	External	1 3/16" x18	653001-3C-05	653002-3C-05
	70-90 454	153	External	1 1/8" x26	653001-3C-07	653002-3C-07
	70-90 454	168	External	1 1/8" x10	653021-3C-04	653022-3C-04
	70-90 454	168	External	1 3/16" x18	653021-3C-05	653022-3C-05
	70-90 454	168	External	1 1/8" x26	653021-3C-07	653022-3C-07
	91-00 454	153	External	1 1/8" x10	653001-4C-04	653002-4C-04
	91-00 454	153	External	1 3/16" x18	653001-4C-05	653002-4C-05
	91-00 454	153	External	1 1/8" x26	653001-4C-07	653002-4C-07
	91-00 454	168	External	1 1/8" x10	653021-4C-04	653022-4C-04
	91-00 454	168	External	1 3/16" x18	653021-4C-05	653022-4C-05
	91-00 454	168	External	1 1/8" x26	653021-4C-07	653022-4C-07
	502	153	External	1 1/8" x10	653001-4A-04	653002-4A-04
	502	153	External	1 3/16" x18	653001-4A-05	653002-4A-05
	502	153	External	1 1/8" x26	653001-4A-07	653002-4A-07
502	168	External	1 1/8" x10	653021-4A-04	653022-4A-04	
502	153	External	1 3/16" x18	653021-4A-05	653022-4A-05	

RACE PRODUCT GUIDE

Mag Force - Strapped Application Guide (cont)

Make	Engine	Ring Gear	Balance	Spline	Single Disc 500 FT LBS	Two Discs 900 FT LBS
Chevrolet	502	168	External	1 1/8" x26	653021-4A-07	653022-4A-07
	98-UP LS	168	Neutral	1 1/8" x10	653051-00-04	653052-00-04
	98-UP LS	168	Neutral	1 3/16" x18	653051-00-05	653052-00-05
	98-UP LS	168	Neutral	1 1/8" x26	653051-00-07	653052-00-07
Ford	2.0L/2.3L Dual Crank Pattern	135	Neutral	1 1/16" x10	653311-00-03	653312-00-03
	2.0L/2.3L Dual Crank Pattern	135	Neutral	1 3/16" x18	653311-00-05	653312-00-05
	2.0L/2.3L Dual Crank Pattern	135	Neutral	1 1/8" x26	653311-00-07	653312-00-07
	289, 302, 351 SB	157 (1)	Neutral	1 1/16" x10	653321-00-03	653322-00-03
	289, 302, 351 SB	157 (1)	Neutral	1 3/16" x18	653321-00-05	653322-00-05
	289, 302, 351 SB	157 (1)	Neutral	1 1/8" x26	653321-00-07	653322-00-07
	289, 302, 351 SB	157 (1)	28 oz	1 1/16" x10	653321-28-03	653322-28-03
	289, 302, 351 SB	157 (1)	28 oz	1 3/16" x18	653321-28-05	653322-28-05
	289, 302, 351 SB	157 (1)	28 oz	1 1/8" x26	653321-28-07	653322-28-07
	302	157 (1)	50 oz	1 1/16" x10	653321-50-03	653322-50-03
	302	157 (1)	50 oz	1 3/16" x18	653321-50-05	653322-50-05
	302	157 (1)	50 oz	1 1/8" x26	653321-50-07	653322-50-07
	289, 302, 351 SB	164 (1)	Neutral	1 1/16" x10	653301-00-03	653302-00-03
	289, 302, 351 SB	164 (1)	Neutral	1 3/16" x18	653301-00-05	653302-00-05
	289, 302, 351 SB	164 (1)	Neutral	1 1/8" x26	653301-00-07	653302-00-07
	289, 302, 351 SB	164 (1)	28 oz	1 1/16" x10	653301-28-03	653302-28-03
	289, 302, 351 SB	164 (1)	28 oz	1 3/16" x18	653301-28-05	653302-28-05
	289, 302, 351 SB	164 (1)	28 oz	1 1/8" x26	653301-28-07	653302-28-07
	4.6/5.4 6 Bolt Crank	164 (1)	Neutral	1 1/16" x10	653361-00-03	653362-00-03
	4.6/5.4 6 Bolt Crank	164 (1)	Neutral	1 3/16" x18	653361-00-05	653362-00-05
	4.6/5.4 6 Bolt Crank	164 (1)	Neutral	1 1/8" x26	653361-00-07	653362-00-07
	4.6/5.4 8 Bolt Crank	164 (1)	Neutral	1 1/16" x10	653381-00-03	653382-00-03
	4.6/5.4 8 Bolt Crank	164 (1)	Neutral	1 3/16" x18	653381-00-05	653382-00-05
	4.6/5.4 8 Bolt Crank	164 (1)	Neutral	1 1/8" x26	653381-00-07	653382-00-07
332 THRU 428 Fe	184	Neutral	1 1/16" x10	653331-00-03	653332-00-03	

RACE PRODUCT GUIDE

Mag Force - Strapped Application Guide (cont)

Make	Engine	Ring Gear	Balance	Spline	Single Disc 500 FT LBS	Two Discs 900 FT LBS
Ford	332 THRU 428 Fe	184	Neutral	1 3/16" x18	653331-00-05	653332-00-05
	332 THRU 428 Fe	184	Neutral	1 1/8" x26	653331-00-07	653332-00-07
	428 Fe	184	28 oz	1 1/16" x10	653331-28-03	653332-28-03
	428 Fe	184	28 oz	1 3/16" x18	653331-28-05	653332-28-05
	428 Fe	184	28 oz	1 1/8" x26	653331-28-07	653332-28-07
	429-460	176	Neutral	1 1/16" x10	653351-00-03	653352-00-03
	429-460	176	Neutral	1 3/16" x18	653351-00-05	653352-00-05
	429-460	176	Neutral	1 1/8" x26	653351-00-07	653352-00-07
	429-460	176	28 oz	1 1/16" x10	653351-28-03	653352-28-03
	429-460	176	28 oz	1 3/16" x18	653351-28-05	653352-28-05
	429-460	176	28 oz	1 1/8" x26	653351-28-07	653352-28-07
MOPAR	6 Bolt Crank	130	Neutral	1" x23	653461-00-02	653462-00-02
	6 Bolt Crank	130	Neutral	1 3/16" x18	653461-00-05	653462-00-05
	6 Bolt Crank	130	Neutral	1 1/8" x26	653461-00-07	653462-00-07
	8 Bolt Crank	130	Neutral	1" x23	653481-00-02	653482-00-02
	8 Bolt Crank	130	Neutral	1 3/16" x18	653481-00-05	653482-00-05
	8 Bolt Crank	130	Neutral	1 1/8" x26	653481-00-07	653482-00-07



RACE PRODUCT GUIDE

Mag Force - Pin Drive Application Guide

Make	Engine	Ring Gear	Balance	Spline	Single Disc 500 FT LBS	Two Discs 900 FT LBS	Three Discs 1500 FT LBS
Chevrolet	55-85 V8	105	Neutral	1 1/8" x10	651011-00-04	651012-00-04	651013-00-04
	55-85 V8	105	Neutral	1 3/16" x18	651011-00-05	651012-00-05	651013-00-05
	55-85 V8	105	Neutral	1 1/8" x26	651011-00-07	651012-00-07	651013-00-07
	55-85 V8	153	Neutral	1 1/8" x10	651001-00-04	651002-00-04	651003-00-04
	55-85 V8	153	Neutral	1 3/16" x18	651001-00-05	651002-00-05	651003-00-05
	55-85 V8	153	Neutral	1 1/8" x26	651001-00-07	651002-00-07	651003-00-07
	55-85 V8	168	Neutral	1 1/8" x10	651021-00-04	651022-00-04	651023-00-04
	55-85 V8	168	Neutral	1 3/16" x18	651021-00-05	651022-00-05	651023-00-05
	55-85 V8	168	Neutral	1 1/8" x26	651021-00-07	651022-00-07	651023-00-07
Chevrolet	86-92 350	153	External	1 1/8" x10	651031-1A-04	651032-1A-04	651033-1A-04
	86-92 350	153	External	1 3/16" x18	651031-1A-05	651032-1A-05	651033-1A-05
	86-92 350	153	External	1 1/8" x26	651031-1A-07	651032-1A-07	651033-1A-07
	86-92 350	168	External	1 1/8" x10	651031-1A-04	651032-1A-04	651033-1A-04
	86-92 350	168	External	1 3/16" x18	651031-1A-05	651032-1A-05	651033-1A-05
	86-92 350	168	External	1 1/8" x26	651031-1A-07	651032-1A-07	651033-1A-07
	383/400	153	External	1 1/8" x10	651001-2C-04	651002-2C-04	651003-2C-04
	383/400	153	External	1 3/16" x18	651001-2C-05	651002-2C-05	651003-2C-05
	383/400	153	External	1 1/8" x26	651001-2C-07	651002-2C-07	651003-2C-07
	383/400	168	External	1 1/8" x10	651021-2C-04	651022-2C-04	651023-2C-04
	383/400	168	External	1 3/16" x18	651021-2C-05	651022-2C-05	651023-2C-05
	383/400	168	External	1 1/8" x26	651021-2C-07	651022-2C-07	651023-2C-07
	70-90 454	153	External	1 1/8" x10	651001-3C-04	651002-3C-04	651003-3C-04
	70-90 454	153	External	1 3/16" x18	651001-3C-05	651002-3C-05	651003-3C-05
	70-90 454	153	External	1 1/8" x26	651001-3C-07	651002-3C-07	651003-3C-07
	70-90 454	168	External	1 1/8" x10	651021-3C-04	651022-3C-04	651023-3C-04
	70-90 454	168	External	1 3/16" x18	651021-3C-05	651022-3C-05	651023-3C-05
	70-90 454	168	External	1 1/8" x26	651021-3C-07	651022-3C-07	651023-3C-07
Chevrolet	91-00 454	153	External	1 1/8" x10	651001-4C-04	651002-4C-04	651003-4C-04
	91-00 454	153	External	1 3/16" x18	651001-4C-05	651002-4C-05	651003-4C-05
	91-00 454	153	External	1 1/8" x26	651001-4C-07	651002-4C-07	651003-4C-07
	91-00 454	168	External	1 1/8" x10	651021-4C-04	651022-4C-04	651023-4C-04
	91-00 454	168	External	1 3/16" x18	651021-4C-05	651022-4C-05	651023-4C-05
	91-00 454	168	External	1 1/8" x26	651021-4C-07	651022-4C-07	651023-4C-07
Chevrolet	502	153	External	1 1/8" x10	651001-4A-04	651002-4A-04	651003-4A-04
	502	153	External	1 3/16" x18	651001-4A-05	651002-4A-05	651003-4A-05
	502	153	External	1 1/8" x26	651001-4A-07	651002-4A-07	651003-4A-07
Chevrolet	502	168	External	1 1/8" x10	651021-4A-04	651022-4A-04	651023-4A-04
	502	153	External	1 3/16" x18	651021-4A-05	651022-4A-05	651023-4A-05
	502	168	External	1 1/8" x26	651021-4A-07	651022-4A-07	651023-4A-07
	98-UP LS	168	Neutral	1 1/8" x10	651051-00-04	651052-00-04	651053-00-04
	98-UP LS	168	Neutral	1 3/16" x18	651051-00-05	651052-00-05	651053-00-05
	98-UP LS	168	Neutral	1 1/8" x26	651051-00-07	651052-00-07	651053-00-07

RACE PRODUCT GUIDE

Mag Force - Pin Drive Application Guide (cont)

Make	Engine	Ring Gear	Balance	Spline	Single Disc 500 FT LBS	Two Discs 900 FT LBS	Three Discs 1500 FT LBS
Ford	2.0L/2.3L Dual Crank Patter	135	Neutral	1 1/16" x10	651311-00-03	651312-00-03	651313-00-03
	2.0L/2.3L Dual Crank Patter	135	Neutral	1 3/16" x18	651311-00-05	651312-00-05	651313-00-05
	2.0L/2.3L Dual Crank Patter	135	Neutral	1 1/8" x26	651311-00-07	651312-00-07	651313-00-07
Ford	289, 302, 351 SB	157 (1)	Neutral	1 1/16" x10	651321-00-03	651322-00-03	651323-00-03
	289, 302, 351 SB	157 (1)	Neutral	1 3/16" x18	651321-00-05	651322-00-05	651323-00-05
	289, 302, 351 SB	157 (1)	Neutral	1 1/8" x26	651321-00-07	651322-00-07	651323-00-07
Ford	289, 302, 351 SB	157 (1)	28 oz	1 1/16" x10	651321-28-03	651322-28-03	651323-28-03
	289, 302, 351 SB	157 (1)	28 oz	1 3/16" x18	651321-28-05	651322-28-05	651323-28-05
	289, 302, 351 SB	157 (1)	28 oz	1 1/8" x26	651321-28-07	651322-28-07	651323-28-07
Ford	302	157 (1)	50 oz	1 1/16" x10	651321-50-03	651322-50-03	651323-50-03
	302	157 (1)	50 oz	1 3/16" x18	651321-50-05	651322-50-05	651323-50-05
	302	157 (1)	50 oz	1 1/8" x26	651321-50-07	651322-50-07	651323-50-07
Ford	289, 302, 351 SB	164 (1)	Neutral	1 1/16" x10	651301-00-03	651302-00-03	651303-00-03
	289, 302, 351 SB	164 (1)	Neutral	1 3/16" x18	651301-00-05	651302-00-05	651303-00-05
	289, 302, 351 SB	164 (1)	Neutral	1 1/8" x26	651301-00-07	651302-00-07	651303-00-07
	289, 302, 351 SB	164 (1)	28 oz	1 1/16" x10	651301-28-03	651302-28-03	651303-28-03
	289, 302, 351 SB	164 (1)	28 oz	1 3/16" x18	651301-28-05	651302-28-05	651303-28-05
	289, 302, 351 SB	164 (1)	28 oz	1 1/8" x26	651301-28-07	651302-28-07	651303-28-07
Ford	4.6/5.4 6 Bolt Crank	164 (1)	Neutral	1 1/16" x10	651361-00-03	651362-00-03	651363-00-03
	4.6/5.4 6 Bolt Crank	164 (1)	Neutral	1 3/16" x18	651361-00-05	651362-00-05	651363-00-05
	4.6/5.4 6 Bolt Crank	164 (1)	Neutral	1 1/8" x26	651361-00-07	651362-00-07	651363-00-07

RACE PRODUCT GUIDE

Mag Force - Pin Drive Application Guide (cont)

Make	Engine	Ring Gear	Balance	Spline	Single Disc 500 FT LBS	Two Discs 900 FT LBS	Three Discs 1500 FT LBS
Ford	4.6/5.4 8 Bolt Crank	164 (1)	Neutral	1 1/16" x10	651381-00-03	651382-00-03	651383-00-03
	4.6/5.4 8 Bolt Crank	164 (1)	Neutral	1 3/16" x18	651381-00-05	651382-00-05	651383-00-05
	4.6/5.4 8 Bolt Crank	164 (1)	Neutral	1 1/8" x26	651381-00-07	651382-00-07	651383-00-07
Ford	332 THRU 428 Fe	184	Neutral	1 1/16" x10	651331-00-03	651332-00-03	651333-00-03
	332 THRU 428 Fe	184	Neutral	1 3/16" x18	651331-00-05	651332-00-05	651333-00-05
	332 THRU 428 Fe	184	Neutral	1 1/8" x26	651331-00-07	651332-00-07	651333-00-07
Ford	428 Fe	184	28 oz	1 1/16" x10	651331-28-03	651332-28-03	651333-28-03
	428 Fe	184	28 oz	1 3/16" x18	651331-28-05	651332-28-05	651333-28-05
	428 Fe	184	28 oz	1 1/8" x26	651331-28-07	651332-28-07	651333-28-07
Ford	429-460	176	Neutral	1 1/16" x10	651351-00-03	651352-00-03	651353-00-03
	429-460	176	Neutral	1 3/16" x18	651351-00-05	651352-00-05	651353-00-05
	429-460	176	Neutral	1 1/8" x26	651351-00-07	651352-00-07	651351-00-07
Ford	429-460	176	28 oz	1 1/16" x10	651351-28-03	651352-28-03	651353-28-03
	429-460	176	28 oz	1 3/16" x18	651351-28-05	651352-28-05	651353-28-05
	429-460	176	28 oz	1 1/8" x26	651351-28-07	651352-28-07	651353-28-07
MOPAR	6 Bolt Crank	130	Neutral	1" x23	651461-00-02	651462-00-02	651463-00-02
	6 Bolt Crank	130	Neutral	1 3/16" x18	651461-00-05	651462-00-05	651463-00-05
	6 Bolt Crank	130	Neutral	1 1/8" x26	651461-00-07	651462-00-07	651463-00-07
MOPAR	8 Bolt Crank	130	Neutral	1" x23	651481-00-02	651482-00-02	651483-00-02
	8 Bolt Crank	130	Neutral	1 3/16" x18	651481-00-05	651482-00-05	651483-00-05
	8 Bolt Crank	130	Neutral	1 1/8" x26	651481-00-07	651482-00-07	651483-00-07

Race Product Guide

Mag Force Replacement Parts

Covers	Light Cone		HD Cone		HD Cone with C/W		
	655501-1R		655501-2R		655501-S		
Discs 8"	Spline	1" x 23	1 1/16" x10	1 1/8" x 10	1 1/8" x 26	1 9/64" x 10	1 3/16" x 18
	Organic	655516-02	655516-03	655516-04	655516-07	655516-21	655516-05
	Ceramic Button	5002-02	5002-03	5002-04	5002-07	5002-10	5002-05
	Sintered Iron (HCF)	5006-02	5006-03	5006-04	5006-07	5006-10	5006-05
Heat-shield	Floater		Pressure Rings			Stand Kits	
655505	Pin Drive	655506	Aluminum	655504		Pin Drive Single	655511
	Strapped	655506-SS	Steel	655504-S2		Pin Drive Dual	655512
			Strapped Steel	655504-SS		Pin Drive Triple	655513
						Strapped Dual	655512ST

RACE PRODUCT GUIDE

Sport Compact Mag Force Assemblies

Make	Application	Spline	Note	Part Number
Mazda	Rotary Engines	1" x 23	Includes Steel Flywheel Assembly	681702-00-02
Mazda	Rotary Engines	1-1/8" x 26	Includes Steel Flywheel Assembly	681702-00-07
Mazda	Rotary Engines With Turbo	1-1/8" x 26	Includes Steel Flywheel Assembly	681712-00-07
Mazda	Rotary Engines	1-3/16" x 18	Includes Steel Flywheel Assembly	681702-00-05
Mazda	Rotary Engines With Turbo	1-3/16" x 18	Includes Steel Flywheel Assembly	681712-00-05
Mitsubishi		1-1/8" x 26	Includes Steel Flywheel Assembly	681902-00-07
Mitsubishi		1-3/16" x 18	Includes Steel Flywheel Assembly	681902-00-05
Toyota	With Stock Diameter 78mm Crank	1-1/8" x 26	Includes Steel Flywheel Assembly	681802-78mm-07
Toyota	With Aftermarket 86mm Crank	1-1/8" x 26	Includes Steel Flywheel Assembly	681802-86mm-07
Toyota	With Stock Diameter 78mm Crank	1-3/16" x 18	Includes Steel Flywheel Assembly	681802-78mm-05
Toyota	With Aftermarket 86mm Crank	1-3/16" x 18	Includes Steel Flywheel Assembly	681802-86mm-05
Toyota	2JZ Engine	1-3/16" x 18	Includes Steel Flywheel Assembly	681822-00-05
Toyota	2RZ/3RZ Engine	1-3/16" x 18	Includes Steel Flywheel Assembly	681832-00-05

Note:
All these assemblies come without ring gears, but the stock ring gear can be installed on these flywheels.

Sport Compact Mag Force Replacement Parts

Covers	Light Cone		HD Cone		
	655501		655501L		
Discs 8"	Spline	1" x 23	1 1/8" x 26	1 3/16" x 18	Floaters
	Sintered Iron (HCF)	5006-02	5006-07	5006-05	655506
Flywheels	Mazda Non-Turbo	Mazda Turbo II	Toyota With 78MM Crank	Toyota With 86MM Crank	Pressure Ring
	68-702	68-712	68-802-78	68-802-86	655504-S2



McLeod Racing

RACE PRODUCT GUIDE

Pro Series Application Guide

Make	Engine	Ring Gear	Balance	Spline	Single Disc up to 1000hp	Twin Disc up to 2000hp	Triple Disc up to 3000hp
Chevrolet	55-85 V8	153	Neutral	1 1/8" x10	43031-00-04	43032-00-04	43033-00-04
	55-85 V8	153	Neutral	1 3/16" x18	43031-00-05	43032-00-05	43033-00-05
	55-85 V8	153	Neutral	1 3/8" x10	43031-00-06	43032-00-06	43033-00-06
	55-85 V8	153	Neutral	1 1/8" x26	43031-00-07	43032-00-07	43033-00-07
	55-85 V8	168	Neutral	1 1/8" x10	43011-00-04	43012-00-04	43013-00-04
	55-85 V8	168	Neutral	1 3/16" x18	43011-00-05	43012-00-05	43013-00-05
	55-85 V8	168	Neutral	1 3/8" x10	43011-00-06	43012-00-06	43013-00-06
	55-85 V8	168	Neutral	1 1/8" x26	43011-00-07	43012-00-07	43013-00-07
	97-UP LS 6 BLT CRANK	168	Neutral	1 1/8" x10	43051-00-04	43052-00-04	43053-00-04
	97-UP LS 6 BLT CRANK	168	Neutral	1 3/16" x18	43051-00-05	43052-00-05	43053-00-05
	97-UP LS 6 BLT CRANK	168	Neutral	1 3/8" x10	43051-00-06	43052-00-06	43053-00-06
	97-UP LS 6 BLT CRANK	168	Neutral	1 1/8" x26	43051-00-07	43052-00-07	43053-00-07
	Ford	64-85 289,302,351 SBF	157 (1)	Neutral	1 1/16" x10	43311-00-03	43312-00-03
64-85 289,302,351 SBF		157 (1)	Neutral	1 3/16" x18	43311-00-05	43312-00-05	43313-00-05
64-85 289,302,351 SBF		157 (1)	Neutral	1 3/8" x10	43311-00-06	43312-00-06	43313-00-06
64-85 289,302,351 SBF		157 (1)	Neutral	1 1/8" x26	43311-00-07	43312-00-07	43313-00-07
64-74 302-351 SBF		164 (1)	Neutral	1 1/16" x10	43321-00-03	43322-00-03	43323-00-03
64-74 302-351 SBF		164 (1)	Neutral	1 3/16" x18	43321-00-05	43322-00-05	43323-00-05
64-74 302-351 SBF		164 (1)	Neutral	1 3/8" x10	43321-00-06	43322-00-06	43323-00-06
64-74 302-351 SBF		164 (1)	Neutral	1 1/8" x26	43321-00-07	43322-00-07	43323-00-07
96-2012 4.6/5.4 8 Bolt Crank		164 (1)	Neutral	1 3/16" x18	43381-00-05	43382-00-05	43383-00-05
96-2012 4.6/5.4 8 Bolt Crank		164 (1)	Neutral	1 3/8" x10	43381-00-06	43382-00-06	43383-00-06
96-2012 4.6/5.4 8 Bolt Crank		164 (1)	Neutral	1 1/8" x26	43381-00-07	43382-00-07	43383-00-07
390,427,428 Fe		184	Neutral	1 3/16" x18	43341-00-05	43342-00-05	43343-00-05
390,427,428 Fe		184	Neutral	1 3/8" x10	43341-00-06	43342-00-06	43343-00-06
390,427,428 Fe		184	Neutral	1 1/8" x26	43341-00-07	43342-00-07	43343-00-07
429-460 Up To 1978		176	Neutral	1 3/16" x18	43351-00-05	43352-00-05	43353-00-05

RACE PRODUCT GUIDE

Pro Series Application Guide (cont)

Make	Engine	Ring Gear	Balance	Spline	Single Disc up to 1000hp	Twin Disc up to 2000hp	Triple Disc up to 3000hp
Ford	429-460 Up To 1978	176	Neutral	1 3/8" x10	43351-00-06	43352-00-06	43353-00-06
	429-460 Up To 1978	176	Neutral	1 1/8" x26	43351-00-07	43352-00-07	43353-00-07
MOPAR	61-78 318, 330,340,383, 400,440 6 Bolt Crank	130	Neutral	1 3/16" x18	43461-00-05	43462-00-05	43463-00-05
	61-78 318, 330,340,383, 400,440 6 Bolt Crank	130	Neutral	1 3/8" x10	43461-00-06	43462-00-06	43463-00-06
	61-78 318, 330,340,383, 400,440 6 Bolt Crank	130	Neutral	1 1/8" x26	43461-00-07	43462-00-07	43463-00-07
	426 8 Bolt Crank	130	Neutral	1 3/16" x18	43481-00-05	43482-00-05	43483-00-05
		130	Neutral	1 3/8" x10	43481-00-06	43482-00-06	43483-00-06
130		Neutral	1 1/8" x26	43481-00-07	43482-00-07	43483-00-07	



RACE PRODUCT GUIDE

Pull Truck Application Guide

Make	Engine	Ring Gear	Balance	Spline	Flywheel Material	Assembly Part Number	
Chevrolet	63-85 327 THRU 427	153	Neutral	1 1/8" x10	Steel	4414-00-04	
	63-85 327 THRU 427	153	Neutral	1 3/8" x10	Steel	4414-00-06	
	63-85 327 THRU 427	153	Neutral	1 1/8" x26	Steel	4414-00-07	
	86-99 350	153	External	1 1/8" x10	Steel	4415-1A-04	
	86-99 350	153	External	1 1/8" x26	Steel	4415-1A-07	
	70-85 400	153	External	1 1/8" x10	Steel	4414-2C-04	
	70-85 400	153	External	1 1/8" x26	Steel	4414-2C-07	
	70-90 454	153	External	1 1/8" x10	Steel	4414-3C-04	
	70-90 454	153	External	1 3/8" x10	Steel	4414-3C-06	
	70-90 454	153	External	1 1/8" x26	Steel	4414-3C-07	
	91-99 454	153	External	1 1/8" x10	Steel	4414-4C-04	
	91-99 454	153	External	1 3/8" x10	Steel	4414-4C-06	
	91-99 454	153	External	1 1/8" x26	Steel	4414-4C-07	
	91-UP 502	153	External	1 1/8" x10	Steel	4414-4A-04	
	91-UP 502	153	External	1 1/8" x26	Steel	4414-4A-07	
	55-85 265 THRU 427	168	Neutral	1 1/8" x10	Steel	4402-00-04	
	55-85 265 THRU 427	168	Neutral	1 3/8" x10	Steel	4402-00-06	
	55-85 265 THRU 427	168	Neutral	1 1/8" x26	Steel	4402-00-07	
	86-99 350	168	External	1 1/8" x10	Steel	4401-1A-04	
	86-99 350	168	External	1 1/8" x26	Steel	4401-1A-07	
	70-85 383/400	168	External	1 1/8" x10	Steel	4402-2C-04	
	70-85 383/400	168	External	1 1/8" x26	Steel	4402-2C-07	
	70-90 454	168	External	1 1/8" x10	Steel	4402-3C-04	
	70-90 454	168	External	1 3/8" x10	Steel	4402-3C-06	
	70-90 454	168	External	1 1/8" x26	Steel	4402-3C-07	
	91-99 454	168	External	1 1/8" x10	Steel	4402-4C-04	
	91-99 454	168	External	1 3/8" x10	Steel	4402-4C-06	
	91-99 454	168	External	1 1/8" x26	Steel	4402-4C-07	
	91-UP 502	168	External	1 1/8" x10	Steel	4402-4A-04	
	91-UP 502	168	External	1 1/8" x26	Steel	4402-4A-07	
	Ford	63-79 289-302-351	164	Neutral	1 1/16" x10	Steel	4461-00-03
				Neutral	1 3/8" x10	Steel	4461-00-06
		63-79 289-302-351	164	28 oz	1" x23	Steel	4461-28-02
			28 oz	1 1/16" x10	Steel	4461-28-03	
			28 oz	1 1/8" x10	Steel	4461-28-04	
			28 oz	1 3/16" x18	Steel	4461-28-05	



Did You Know?

When Saleen built the S7 supercar, Steve Saleen came to McLeod for the clutch. A special design one off Mag Force.

RACE PRODUCT GUIDE

Pull Truck Application Guide (cont)

Make	Engine	Ring Gear	Balance	Spline	Flywheel Material	Assembly Part Number
Ford			28 oz	1 3/8" x10	Steel	4461-28-06
			28 oz	1 1/8" x26	Steel	4461-28-07
	351m/400m	180	28 oz	1 1/16" x10	Steel	Special Order Call!
	63-74 332 THRU 427 Fe	184	Neutral	1 1/16" x10	Steel	4481-00-03
			Neutral	1 3/8" x10	Steel	4481-00-06
	63-74 332 THRU 427 Fe	184	28 oz	1 1/16" x10	Steel	4481-28-03
			28 oz	1 3/8" x10	Steel	4481-28-06
	69-78 429-460	176	28 oz	1 1/16" x10	Steel	4483-00-03
			28 oz	1 1/8" x10	Steel	4483-00-04
			28 oz	1 3/8" x10	Steel	4483-28-06
	79-99 460	176	28 oz	1 1/16" x10	Steel	4483-28-03
			28 oz	1 1/8" x10	Steel	4483-28-04
			28 oz	1 3/8" x10	Steel	4483-28-06
			28 oz	1 1/4" x10	Steel	4483-28-32
	69-78 429-460	180	Neutral	1 1/16" x10	Steel	4487-00-03
			Neutral	1 3/8" x10	Steel	4487-00-06
	79-99 460	180	28 oz	1 1/16" x10	Steel	4487-28-03
	MOPAR	64-99 318 THRU 440 6 Bolt	130	Neutral	1" x23	Steel
			Neutral	1 1/8" x10	Steel	4423-00-04
			Neutral	1 3/16" x18	Steel	4423-00-05
58-78 383 THRU 440		143	Neutral	1" x23	Steel	4443-00-02
			Neutral	1 3/16" x18	Steel	4443-00-05
			Neutral	1 3/8" x10	Steel	4443-00-06
			Neutral			
			Neutral			
66-69 426 8 Bolt Crank		130	Neutral	1" x23	Steel	4421-00-02
			Neutral	1 3/16" x18	Steel	4421-00-05
			Neutral	1 3/8" x10	Steel	4421-00-06
			Neutral			
66-69 426 8 Bolt Crank	143	Neutral	1" x23	Steel	4441-00-02	
		Neutral	1 1/8" x10	Steel	4441-00-04	
		Neutral	1 3/16" x18	Steel	4441-00-05	

RACE PRODUCT GUIDE

Pull Truck Replacement Parts

Pressure Plates 10.5"							
4.0:1 Bronze Heat Shield	5022						
4.8:1 Bronze Heat Shield	5023						
Discs 10.5"							
Splines							
1" x 10	1" x 23	1 1/16" x10	1 1/8" x 10	1 1/8" x 26	1 3/16" x 18	1 1/4" x 10	1 3/8" x 10
5004-01	5004-02	5004-03	5004-04	5004-07	5004-05	5004-32	5004-06
Heatshields		Floater			Stand Kit		
Bronze 12 Rivet	503105		Steel 3 Ear	5010		2 Disc	5016-2
Steel 27 Rivet	504106					3 Disc	5016-3
Counterweight - Puller with Counterweight		P/P Cover		Pressure Ring			
1530		P40198R		P41196			
Pressure Ring	Springs (12 req.)	Spring Pads (12 req.)	Levers 4:0:1 (3 req.)	Levers 4:8:1 (3 req.)	Lever Yoke (3 req.)	Lever Bushing (3 req.)	
P41196	P10301	P10401	P31006	P31001	P30964	P30661	



Racing Disc Application Guide

O.D. & Spline	Disc Diameter	300 Series	400 Series	700 Series	Sintered Iron	Soft Lok
PP Side		Organic	4 Paddle Sprung	Organic	LCF	HCF*
Flywheel Side		Metal Backed	Bronze Buttons	Organic	LCF	HCF*
Hub Style		Sprung	Sprung	Solid	Solid	Solid
Thickness		.305"	.330"	.305"	.330"	{3}
Racing Style		DR & RR**	DR & RR**	DR**	DR & TP**	DR**
1" x 23 Spl	8"					5006-02 (4)
	10"					5007-02 (4)
	10.5"	260320	260420	260720	5004-02 (4)	5008-02 (4)
	11"	260321		260721	5005-02 (4)	5009-02 (4)
1 1/16" x 10 Spl	8"					5006-03 (4)
	10"					5007-03 (4)
	10.5"	260330	260430	260730	5004-03 (4)	5008-03 (4)
	11"	260331		260731	5005-03 (4)	5009-03 (4)
1 1/8" x 10 Spl	8"					5006-04 (4)
	9 1/8"					
	10"					5007-04 (4)
	10.5"	260340	260440	260740	5004-04 (4)	5008-04 (4)
	11"	260341		260741	5005-04 (4)	5009-04 (4)
1 1/8" x 26 Spl	8"					5006-07 (4)
	10"					5007-07 (4)
	10.5"	260370	260470	260770	5004-07 (4)	5008-07 (4)
	11"	260371		260771	5005-07 (4)	5009-07 (4)
1 3/16" x 18 Spl	8"					5006-05 (4)
	10"					5007-05 (4)
	10.5"	260350	260460	260750	5004-05 (4)	5008-05 (4)
	11"	260351		260751	5004-05 (4)	5009-05 (4)
1 3/8" x 10 Spl	10"					5007-06 (4)
	10.5"	260360	260470	260760	5004-06 (4)	5008-06 (4)
	11"	260361		260761	5005-06 (4)	5009-06 (4)

* LCF= Low Coefficiency Of Friction

* HCF=High Coefficiency Of Friction

** DR = Drag Racing OT = Oval Track Racing TP = Truck Pull RR = Road & Slalom Racing

Footnotes:

1. McLeod has over 30 splines available for discs. Please refer to the Clutch Disc Buyers Guide for McLeod Spline Numbers
2. McLeod offers many other discs. Numerous combinations are available. Please McLeod call if yours is not listed above.
3. HCF discs are standard .280" thick. They can be order .330" thick. Please add a "J" to the end of the part number for .330" thick.

RACING PRESSURE PLATE APPLICATION GUIDE



Diaphragm Style

The Diaphragm Style pressure plate has grown in popularity since its introduction in the 1950's. McLeod's diaphragm pressure plates work exceptionally well for street or street & strip applications, featuring maximum clamp load with minimal pedal effort.

Borg & Beck Style

The Borg & Beck pressure plate is the original OEM designed clutch units for GM and Chrysler vehicles. The McLeod version is available with or without centrifugal rollers for additional holding power in the higher horsepower applications. McLeod offers a full line of Borg & Beck pressure plates as well as replacement parts.



Long Style

The Ford Long Style pressure plate is the racer's favorite. These pressure plates offer extremely quick shifts in a light-weight and completely adjustable design. This pressure plate with minor modifications is used with the NHRA & IHRA record holding Soft-Lok assembly.

Borg & Beck Long Style

A McLeod Exclusive

The Borg & Beck Long pressure plate is a McLeod exclusive that integrates the heavy-duty hat of the original Borg & Beck with Ford long style fingers for extremely quick ratios. These pressure plates are used in street and race applications where accuracy, consistency and quick shifts are required.



RACING PRESSURE PLATE APPLICATION GUIDE

Pressure Plate Application Guide

Description	Size	Bolt Pattern	Style	Fixed Or Adjustable Pressure	Fixed Pressure	Base To Max Pressure	Heat Shield Material	Pressure Ring Material	Type Of Racing*	Part Number
Aluminum Pressure Ring	10.4"	11-5/8"	Diaphragm	Fixed	2900		Steel	Aluminum	OT/RR	365709 (1)
Extra Straps										
	10.5"	11-5/8"	Diaphragm	Fixed	2900			Ductile	OT/RR	360700-5
	10.5"	11-5/8"	Diaphragm	Fixed	2900		Steel	Aluminum	OT/RR	360700-5A (2)
	11"	11-3/8"	Diaphragm	Fixed	2400			Ductile	OT/RR	360850-5
Mustang 1986-2000 Bolt Pattern										
	10.5"	11-3/8"	Diaphragm	Fixed	2400			Ductile	OT/RR	360048-5
	10.5"	11-3/8"	Diaphragm	Fixed	2400		Steel	Aluminum	OT/RR	360048-5A (2)
Pull Truck										
	11"	3-3/8"	Long	Fixed	2400		Bronze	Ductile	DR	360532
Soft Lok										
	10"	3-1/8"	Long	Adjustable		1500 To 1850	Steel	Aluminum	DR	360440
	10.5" 11"	3-3/8"	Long	Adjustable		150 To 1850	Steel	Aluminum	DR	360540
	11"	3-3/8"	Long	Adjustable		150 To 1850	Steel	Aluminum	DR	360550
Turbo Applications										
6 Roller - 360326 Only	10.95"	11-5/8"	B & B	Fixed	2500		Bronze	Ductile	DR	360326
	11"	3-3/8"	Long	Fixed	2400		Bronze	Ductile	DR	360532
	11"	3-3/8"	Long	Adjustable		1100 To 2400	Bronze	Ductile	DR	360536
Unlimited RPM Shifting										
	10.4"	3-1/8"	Long	Fixed	2500			Ductile	DR/OT	360420(2)
	10.4"	3-1/8"	Long	Adjustable		1100 To 2400			DR	360425
	10.95"	11-5/8"	BB Long	Fixed	2400			Ductile	DR	360952
	10.95"	11-5/8"	BB Long	Fixed	2700			Ductile	DR	360955
	11"		Long	Fixed	2500			Ductile	DR	360530(2)
	11"	3-3/8"	Long	Adjustable		1100 To 2400		Ductile	DR	360535
Up To 7500 RPM Shifting With Counterweight										
	10.95"	11-5/8"	BB Long	Fixed	2400			Ductile	DR	360951
	11"	12-5/8"	BB Long	Fixed	2400			Ductile	DR	360531 (2)
* DR = Drag Racing OT = Oval Track Racing RR = Road and Slalom Racing										
Footnotes: (1) Special Order (2) Specify Disc Type When Ordering ie. Organic or Puck Iron										

THROW-OUT BEARINGS

Hydraulic Throw-Out Bearing

McLeod Hydraulic Bearings are made of the finest hard-anodized billet aluminum, along with quality elbow swivel fittings and high-pressure stainless steel braided lines.

Our Hydraulic Bearings are available in both bolt on and slip on styles. The Slip On Bearings are good for most applications. The Bolt On applications are for where clearance is tight. Refer to page 115.

These assemblies may be used to eliminate the need to fabricate complex clutch linkage when swapping transmissions.



Hydraulic Conversion Kits

McLeod Direct Fit Hydraulic Kits are ideal for cars that have inferior mechanical linkage or need extra space due to a motor swap or other changes. McLeod Direct Fit Hydraulic Kits are designed for ease of install and great life.

Vehicle specific and produces improved performance of the clutch system and better durability.

Easier pedal effort to making shifting through the gears easier than you imagined.

All have a Self-Adjusting bearing feature. No more adjusting the clutch every 4 – 6 months. The hydraulic kit will allow the bearing to self adjust when the disc wears throughout it is life cycle.



Mustang Hydraulic Replacement Kit for Cable Linkage shown

THROW-OUT BEARINGS

Adjustable Throw-Out Bearing

The McLeod Adjustable Mechanical Throwout Bearing is an exclusive design. It allows for easy, proper fitment by simply removing or adding spacer rings between the two-piece collar.

Adjustable To 3 Different Heights
Available For Ford and
GM Applications



Mechanical Bearing

McLeod Mechanical Throwout Bearings replace the stock throwout bearings with an angular-contact, constant contact bearing for long life and durability.



Wide Selection
Great Quality At An Excellent Value

Throw-Out Bearings

THROW-OUT BEARINGS APP GUIDE

Hydraulic Throw-Out Bearings - Bolt On Application Guide

Make	Application	Spline	Stock Collar I.D.	Assembly	Assembly With Master Cylinder	Assembly With Line Launch
General Motors	Borg Warner T-10 & Super T-10	1 1/8" x 10 & 1 1/8" x 26	4.680"	1301	13015	130151
	Borg Warner T-5 & T56 Aftermarket Replacement	1 1/8" x 26	4.680"	1302	13025	130251
	Chevy II 1962-1963	1 1/8" x 10	4.180"	1326	13625	132651
	Corvette 1953-1965	1 1/8" x 10	4.680"	1340	13405	134051
	Corvette 1963	1 1/8" x 10	4.180"	1326	13625	132651
	G- Force 5 & 6 Speed	1 1/8" x 10 & 1 3/16" x 18	4.680"	1301	13015	130151
	Jerico 5192DR 5 Speed Bolt Pattern 4.000:	ALL	4.680"	1366	13665	136651
	Jerico Late Model 5 Speed Bolt Pattern 4.250"	ALL	4.680"	1368	13685	136851
	Lenco ST1200 Street 5 Speed	1 1/8" x 10 & 1 1/8" x 26	4.680"	1351ST	13515ST	135151ST
	Muncie	1 1/8" x 10 & 1 1/8" x 26	4.680"	1300	13005	130051
	Nova 1962-1963	1 1/8" x 10	4.180"	1326	13625	132651
	NV4500 Truck 1993-1995 Tapered Front Bearing	1 1/8" x 10	5.125"	1361	13615	
	NV4500 Truck 1996-Up Tapered Front Bearing	1 1/18" x 10 & 1 3/8" x 10	5.600"	1362	13625	
	Saginaw	1 1/8" x 10	4.680"	1327	13275	132751
	SM465 Truck 4 Speed with Compound Low	1 1/8" x 10	5.120"	1321	13215	132151
	T56 Camaro 1998-2002 with Qwik Disconnect Female Line	1 1/8" x 26		1373	13735	137351
	T56 Camaro with AN4 Male Fitting	1 1/8" x 26		1372	13725	137251
	T56 Corvette C5 & C6 with Qwik Disconnect Female Line	1 1/8" x 26		1374	13745	137451
	Tremec 5 Speeds TKO500/600, 3550 & TKO, 2057	1 1/8" x 26	4.680"	1364	13645	136451
	ZF 6 Speed Corvette - For Push Style Clutches	1 1/8" x 26	4.680"	1345	13455	134551

Direct Fit Hydraulic Conversion Kits

Application	Model Year	Transmission	Slave Cylinder Included	Part Number
GENERAL MOTORS				
Tri Five	1955-1957	All	NO {1}	1434001
Camaro	1967-1969	All	NO {1}	1434002
	1970-1981	All	NO {1}	1434005
Chevelle	1963-1972	All	NO {1}	1434004
Nova	1963-1967	All	NO {1}	1434003
	1968-1972	All	NO {1}	1434002

Note:

1. Use the correct McLeod hydraulic bearing for your transmission found on pages 94-95

THROW-OUT BEARINGS APP GUIDE

Hydraulic Throw-Out Bearings - Bolt On Application Guide (cont)

Make	Application	Spline	Stock Collar I.D.	Assembly	Assembly With Master Cylinder	Assembly With Line Launch
Ford	Borg Warner T-5 5 Speed	1 1/16" x 10	4.910"	1319	13195	131951
	Ford 3 & 4 Speed	1 1/16" x 10	4.850"	1304	13045	130451
	G-Force 4 Speed	1 3/8" x 10	4.850"	1305	13055	130551
	G-Force 5 & 6 Speed	1 1/8" x 26	4.850"	1309	13095	130951
	Jerico 5192DR 5 Speed Bolt Pattern 4.000:	ALL	4.850"	1367	13675	136751
	Jerico Late Model 5 Speed Bolt Pattern 4.250"	ALL	4.850"	1369	13695	136951
	Lenco ST1200 Street 5 Speed	ALL	4.850"	1353ST	13535ST	135351ST
	Richmond 5 & 6 Speed (Formerly Doug Nash)	1 1/8" x 26 & 1 3/16" x 18	4.850"	1309	13095	130951
	Top Loader 3 & 4 Speed	1 1/16" x 10	4.850"	1304	13045	130451
	Top Loader 4 Speed (Rock Crusher)	1 3/8" x 10	4.850"	1305	13055	130551
	Tremec 5 Speeds TKO500/600, 3550 & TKO, 2057	1 1/8" x 26	4.680"	1364	13645	136451
	Truck with 6.9 Diesel	1 1/16" x 10	4.850"	1341	13415	134151
MOPAR	A833 4 Speed	1" x 23	4.350"	1322	13225	132251
	Richmond 5 & 6 Speed (Formerly Doug Nash)	1 1/8" x 26 & 1 3/16" x 18	4.807"	1330	13305	133051
	NV4500 V10 Truck 1993-2003	1 1/4" x 10 & 1 3/8" x 10	5.125"	1362	13625	
	T56 Viper with AN4 Male Fitting	1 1/8" x 26		1372	13725	137251
BellHousing Mounted	Lenco & Jeffco 4 Speed Chevy Register (9)	ALL	4.680"	1351	13515	135151
	Lenco & Jeffco 4 Speed Chrysler Register (9)	ALL	4.850"	1353	13535	135351
	Lenco & Jeffco 4 Speed Ford Register (9)	ALL	4.807"	1354	13545	135451

Footnotes:

(9) TO CONVERT REGULAR LENCO TO ST1200, A DOUBLE MALE ADAPTER PART NO. 139018 IS REQUIRED

Direct Fit Hydraulic Conversion Kits (cont)

Application	Model Year	Transmission	Slave Cylinder Included	Part Number
FORD				
Mustang	1964-1966		NO {1}	1431001
	1979-1995	T5 & TKO 500/600	Internal	14-325
	1979-2004	All	External Slave	14-326
Mustang GT	1996-2004	T-45 & TR3650	Internal	14-327
Mustang Cobra	2003-2004	T-56	Internal	14-327

Note:

1. Use the correct McLeod hydraulic bearing for your transmission found on pages 94-95

THROW-OUT BEARINGS APP GUIDE

Hydraulic Throwout Bearings - Slip On Application Guide

Make	Application	Spline	Stock T.O. Bearing I.D.	Assembly	Assy With Master Cylinder ^[1]	Assy With Line Launch ^[1]	Spacer Sleeve ^[2]
General Motors	Borg Warner T-10 3 & 4 Speed	1 1/8" x10 & 1 1/8" x26	1.375"	1400-20	14005-20	140051-20	1429
	Borg Warner T-5, T-50 5 Speed	1" x 14" & 1 1/8" x 26	1.375"	1400-20	14005-20	140051-20	1429
	G-Force 5 & 6 Speed	1 1/8" x 26	1.375"	1400-20	14005-20	140051-20	1429
	Jerico 4 & 5 Speed	1 1/8" x26 & 1 3/16" x18	1.375"	1400-20	14005-20	140051-20	1429
	Jerico 2, 3 & 4 Speed All	1 1/8" x26 & 1 3/16" x18	1.375"	1400-20	14005-20	140051-20	1429
	Jerico 4 & 5 Spd with 3.347" Frt Brg	1 3/8" x 10 [3]	1.750"	1400-74	14005-74	140051-74	N/A
	Jerico 2, 3 & 4 Spd w/3.542" Frt Brg	1 3/8" x 10 [4]	1.750"	1400-75	14005-75	140051-75	N/A
	Liberty 5 & 6 Speed	1 3/16" x 18	1.375"	1400-20	14005-20	140051-20	1429
	Muncie 4 Speed	1 1/8" x10 & 1 1/8" x26	1.375"	1400-20	14005-20	140051-20	1429
	Richmond 5 & 6 Speeds	1 1/8" x 26	1.375"	1400-20	14005-20	140051-20	1429
	Saginaw 3 & 4 Speeds	1 1/8" x10 & 1 1/8" x26	1.375"	1400-20	14005-20	140051-20	1429
	Tremec 5 Speed TKO	1 1/8" x 26	1.375"	1400-20	14005-20	140051-20	1429
	Truck 4 Speed W/Compound Low	1 1/8" x 10	1.375"	1400-20	14005-20	140051-20	1429
	Truck 5 Spd HM290 Getrag w/O.D.	1 1/8" x 10	1.375"	1400-20	14005-20	140051-20	1429
	016 T56 Cam/Firebird 1993-1997	1 1/8" x 26	1.375"	1400-22	14005-22	140051-22	N/A
	011 T56 Aftermkt w/spacer & collar	1 1/8" x 26	1.375"	1400-20	14005-20	140051-20	1429
	Ford	Borg Warner T-5 Thru 1993	1 1/16" x 10	1.430"	1406-30	14065-30	140651-30
Borg Warner T-5 Thru 1994-1995		1 1/16" x 10	1.430"	1406-30	14065-30	140651-30	1439
Borg Warner T-45 1996 and up		1 1/16" x 10	1.430"	1400-30	14005-30	140051-30	1439 ^[5]
Ford 3 & 4 Speed		1 1/16" x 10	1.430"	1400-30	14005-30	140051-30	1439
G-Force 5 & 6 Speed		1 1/8" x 26	1.430"	1400-30	14005-30	140051-30	1439
Jerico 4 & 5 Speed		1 1/8" x26 & 1 3/16" x18	1.430"	1400-30	14005-30	140051-30	1439
Jerico 4 & 5 Spd with 3.347" Frt Brg		1 3/8" x 10 [3]	1.750"	1400-74	14005-74	140051-74	N/A
Jerico 2, 3 & 4 Spd w/3.542" Frt Brg		1 3/8" x 10 [4]	1.750"	1400-75	14005-75	140051-75	N/A
Liberty 5 & 5 Speed		1 3/16" x 18	1.430"	1400-30	14005-30	140051-30	1439
Magnum T-56 Ford Aftermkt 6 Spd		1 1/16" x 10	1.430"	1400-30	14005-30	140051-30	1439
Richmond 5 & 6 Speeds		1 1/8" x 26	1.430"	1400-30	14005-30	140051-30	1439
Top Loader 3 & 4 Speeds		1 1/16" x 10	1.430"	1400-30	14005-30	140051-30	1439
Top Loader 4 Speed		1 3/8" x 10	1.750"	Use Bolt On	Use Bolt On	Use Bolt On	
Tremec T-56 Ford Aftermkt 6 Spd		1 1/8" x 26	1.430"	1400-30	14005-30	140051-30	1439
Tremec Ford TKO 500/600 & 3550		1 1/16" x 10	1.430"	1406-30	14065-30	140651-30	1439 ^[6]
Truck 4 Speed 6.9L Diesel		1 1/16" x 10	1.430"	1400-30	14005-30	140051-30	1439
Chrysler		A833 4 Speed	1" x 23	1.250"	1400-10	14005-10	140051-10
	440 cid & 426 cid Engines 4 Spd	1 3/16" x 18	1.410"	1400-30	14005-30	140051-30	1439
	G-Force 5 & 6 Speeds	1 1/8" x 26	1.410"	1400-30	14005-30	140051-30	1439
	Jerico 4 & 5 Speed	1 1/8" x26 & 1 3/16" x18	1.410"	1400-30	14005-30	140051-30	1439
	Jerico 4 & 5 Spd with 3.347" Frt Brg	1 3/8" x 10 [3]	1.750"	1400-74	14005-74	140051-74	N/A
	Jerico 2, 3 & 4 Spd w/3.542" Frt Brg	1 3/8" x 10 [4]	1.750"	1400-75	14005-74	140051-75	N/A
	Liberty 5 & 6 Speed	1 3/16" x 18	1.410"	1400-30	14005-30	140051-30	1439
	Richmond 5 & 6 Speed	1 1/8" x 26	1.410"	1400-30	14005-30	140051-30	1439

Footnotes:

- [1] Adjusting sleeve is included with each assembly.
- [2] Spacer sleeve is shown for assemblies, which require them.
- [3] 139074 replacement adjusting collar is included in this application.
- [4] 139075 replacement adjusting collar is included in this application.
- [5] May require two spacer sleeves if bearing won't adjust with one.
- [6] Use with Tremec TKO with long input shaft.
- [7] Spacer sleeve if needed is 1429.
- [8] Spacer sleeve if needed is 1439.
- [9] To convert regular Lenco to start ST1200 a double male adapter part NO. 139018 is required.
- [10] Use 8-118-1 steel billet collar.

THROW-OUT BEARINGS APP GUIDE

Mechanical Throw-Out Bearings

Make	Description	Height	Collar I.D.	Bearing Face	Part Number
GENERAL MOTORS					
	Adjustable To 3 Lengths - Short	1.580"	1.375"	2.750"	16505
	Adjustable To 3 Lengths - Medium	1.755"	1.375"	2.750"	16505
	Adjustable To 3 Lengths - Long	1.930"	1.375"	2.750"	16505
	Use With Diaphragm Pressure Plates and 12" Borg & Beck	1.225"	1.375"	2.640"	16010
	Use With All Flat Cone Diaphragms on Early G.M. Vehicles	1.885"	1.375"	2.560"	16090
FORD					
	Use With 1-1/16" 3&4 Speed Transmissions	1.440"	1.435"	2.800"	16031
	Use With 1-3/8" 4 Speed Top Loaded Transmissions	1.500"	1.750"	3.325"	16042
	Use With 1-1/16" T-5, T-45, Tremec 3550, & 1-1/8x26 Tremec TKO	1.340"	1.435"	2.640"	16100
	Adjustable To 3 Lengths - Short	1.586"	1.435"	2.750"	16515
	Adjustable To 3 Lengths - Medium	1.750"	1.435"	2.750"	16515
	Adjustable To 3 Lengths - Long	1.940"	1.435"	2.750"	16515
	2.0L & 2.3L ENG. With 1x23 Spline German Transmission	1.430"	1.335"	2.600"	16080
CHRYSLER MOTORS					
	Use with All 1x23 Spline A833 Transmissions	2.000"	1.255"	2.640"	16053
	Use With All 1-3/16x18 Spline Transmission 426 & 440" Engines	2.120"	1.435"	2.800"	16061
	Use With Some 1x10 Spline AMC & Jeeps	1.675"	1.320"	2.640"	16073
PANTERA					
	Adjustable To Bearing, This Is Stock Height	2.225"	1.327"	2.750"	16525
	Adjustable To Bearing - .200" Shorter	2.025"	1.327"	2.750"	16525
	Adjustable to Bearing - .400" Shorter	1.825"	1.327"	2.750"	16525



Did You Know?

Paul Lee, McLeod's owner and president, got his start in racing by "borrowing" his mom's Plymouth Duster and taking it to Atco Dragway on Friday nights.

THROW-OUT BEARINGS APP GUIDE

Throw-Out Bearings Replacement Parts & Accessories

Part Type	Description	Part Number
Choke Ring	To Fit Saginaw Bearing	139045
Expander Ring	4.680 To 4.850	139040
	4.680 To 4.910	139041
	4.807 To 5.120	139042
	4.680 To 5.120	139043
	4.680 To 4.807	139044
	4.358 To 4.807	139046
	4.358 To 5.125	139047
	4.180 To 4.680	139048
	4.850 To 5.125	139049
	5.125 To 4.910	8701-1
	5.125 To 4.850	8701-2
	5.125 To 4.807	8701-3
	5.125 To 4.680	8701-4
	5.125 To 4.350	8701-5
Fitting	Double Male For M/C 2/8x24 X AN-4	139003
	Double Male For Inlet, AN-4 On Both Ends	139017
	Elbo Swivel Assy W/Roll Pin, O' Ring	139013
	Roll Pin Male To AN4 Male Straight	139026
	Roll Pin Male To AN4 Male Elbo	139027
	Roll Pin Male To AN3 Male Elbo	139028
	Banjo Assy Without Stato Seal	139014
	Bleeder Screw	139016
	Qwik Disconnect Fitting Assy No Lines	139200
	Qwik Disconnect Fitting Females Only No Lines	139201
	Qwik Disconnect Fitting Male End Only No Line	139202
Flex Line	Qwik Disconnect Fitting Female With 3" AN4 Line	139203-03
	Qwik Disconnect Fitting Female With 6" AN4 Line	139203-06
	Qwik Disconnect Fitting Female With 11" AN4 Line	139203-11
	Qwik Disconnect Fitting Female With 17" AN4 Line	139203-17
	Qwik Disconnect Fitting Male With 3" AN4 Line	139204-03
	Qwik Disconnect Fitting Male With 6" AN4 Line	139204-06
	Qwik Disconnect Fitting Male With 11" AN4 Line	139204-11

THROW-OUT BEARINGS APP GUIDE

Throw-Out Bearings Replacement Parts & Accessories (cont)

Part Type	Description	Part Number
Flex Line	Qwik Disconnect Fitting Male With 17" AN4 Line	139204-17
	Qwik Disconnect Fitting Male With 24" AN4 Line	139204-24
	Qwik Disconnect Fitting Male With 30" AN4 Line	139204-30
	Qwik Disconnect Fitting Male With 36" AN4 Line	139204-36
	Qwik Disconnect Fitting Male With 39" AN4 Line	139204-39
	Qwik Disconnect Fitting Male With 42" AN4 Line	139204-42
	Qwik Disconnect Fitting Male With 48" AN4 Line	139204-48
	Qwik Disconnect Fitting Male With 60" AN4 Line	139204-60
	Qwik Disconnect Assy Camaro 1998-2003	139210
	Qwik Disconnect Fitting Female Camaro 1998-2003	139211
	Qwik Disconnect Fitting Male Camaro 1998-2003	139212
	Qwik Disconnect Fitting 22.5" Male Line Only	139213
	Qwik Disconnect Assy Vette 1997-Up	139216
	Qwik Disconnect Fitting Female Vette 1997-Up	139217
	Qwik Disconnect Fitting Male Vette 1997-Up	139218
	Qwik Disconnect Line Assy Vette 2005-Up 36"	139222
	Steel Braided Bleed Line 11" Large, 1 End Rigid	139009-11
	Steel Braided Bleed Line 18" Large, 1 End Rigid	139009-18
	Steel Braided Bleed Line 24" Large, 1 End Rigid	139009-24
	Steel Braided Flex Line 11" AN4 Females	139010
	Steel Braided Flex Line 6" AN4 Females	139100-06
	Steel Braided Flex Line 13" AN4 Females	139100-13
	Steel Braided Flex Line 24" AN4 Females	139100-24
	Steel Braided Flex Line 30" AN4 Females	139100-30
	Steel Braided Flex Line 36" AN4 Females	139100-36
	Steel Braided Flex Line 40" AN4 Females	139100-40
	Steel Braided Flex Line 42" AN4 Females	139100-42
	Steel Braided Flex Line 48" AN4 Females	139100-48
Steel Braided Flex Line 60" AN4 Females	139100-60	
Master Cylinder	13/16" Bore Vette 1997-2003	139300
	13/16" Bore Camaro 1998-2002	139301
	3/4" Bore Compact Universal	139302
	5/8" Bore Compact Universal	139304
	13/16" Bore Camaro 1984-1997	139305

THROW-OUT BEARINGS APP GUIDE

Throw-Out Bearings Replacement Parts & Accessories (cont)

Part Type	Description	Part Number
Piston	Small Diameter Piston	
	1.740" Long #1 For 1.590" I.D. Bearing	139031
	1.940" Long #2 For 1.590" I.D. Bearing	139032
	2.140" Long #3 For 1.590" I.D. Bearing	139033
	2.340" Long #4 For 1.590" I.D. Bearing	139034
	2.540" Long #5 For 1.590" I.D. Bearing	139035
	2.740" Long #6 For 1.590" I.D. Bearing	139036
	2.940" Long #7 For 1.590" I.D. Bearing	139037
	3.140" Long #8 For 1.590" I.D. Bearing	139038
	Large Diameter Piston	
	1.650" Long #1 For 1.900" I.D. Bearing	139031-1
	1.850" Long #2 For 1.900" I.D. Bearing	139032-1
	2.050" Long #3 For 1.900" I.D. Bearing	139033-1
	2.250" Long #4 For 1.900" I.D. Bearing	139034-1
	2.450" Long #5 For 1.900" I.D. Bearing	139035-1
	2.650" Long #6 For 1.900" I.D. Bearing	139036-1
	2.850" Long #7 For 1.900" I.D. Bearing	139037-1
	3.050" Long #8 For 1.900" I.D. Bearing	139038-1
Repair Kit	(6 O' Rings) 2nd Generation Elbo Fittings	139115
Seal Kit	For 3/4" Master Cylinder	139061
Slave Cylinder	Universal Mount 7/8" Bore	139006
	Camaro 1993-1997 Steel 7/8" Bore	139024
Misc.	3.000" O.D. Bearing For Hydraulic Assemblies	139050
	3.200" O.D. Bearing For Hydraulic Assemblies	139050-1
	Round Face Bearing For Flat Diaphragm SML ID	139055



Did You Know?

When STS Turbo decided to build its famous ZR7 Corvettes, it came to McLeod for an RXT Twin Disc to hold the power on their twin turbo'd street giants.



BELLHOUSINGS

Aluminum SFI Bellhousings

McLeod's new Spun Aluminum SFI 6.1 Approved Bellhousings have proven that an SFI approved spun aluminum bellhousing can be bought at a very affordable price.

Using a spun aluminum machining process, McLeod is able to produce an extremely accurate bellhousing that is lightweight and compact in size. The backplate is then made from cnc machined 6061 T6 aluminum.

The McLeod Aluminum SFI 6.1 Approved Bellhousing weighs only 14 lbs. But don't let that give the impression that bellhousing is a lightweight. Added protection is provided via a steel inner liner with a TMS Titanium liner option.

We built the bellhousing with a narrow body. It is designed to leave plenty of tunnel room for tight builds. Our upgraded race version includes a block plate for a small additional cost.

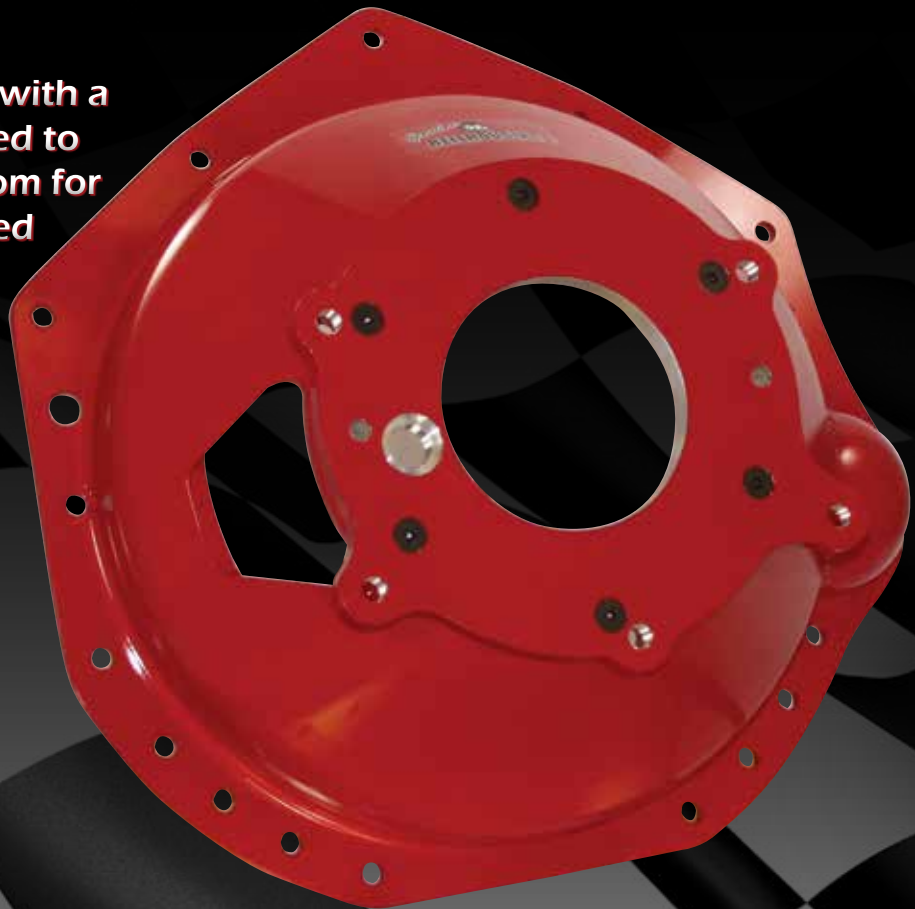

Lightweight 13.5 lbs

Steel Inner Liner

Race Versions Include SFI 6.1 Sticker & Block Plate

Narrow Body For Tight Tunnels

Interchangeable Transmission Mounting Plate To Allow For

Different Transmissions

Fits both small (153) and large (168) diameter Flywheels

SFI Bellhousings Breakdown

Street Version - No Block Plate		
1955-1997	Chevrolet V8	8533
1997-2014	LSx	
Includes Register Ring 5.125" Transmission Patterns: Muncie & Saginaw Depth: 6.360"		
Race Version With Block Plate Included		
1955-1997	Chevrolet V8	8530
1997-2014	LSx	
Includes Register Ring 5.125" Transmission Patterns: Muncie & Saginaw Depth: 6.360" without Motor Plate Motor Plate: .125" Thick		
Street Version - No Block Plate		
1963-2001	Ford 289, 302, & 351	8563
Includes Register Ring 4.850" and 4.910" Transmission Patterns: T5 and TKO Depth: 6.785"		
Fits 164 tooth ring gear		
Race Version With Block Plate Included		
1955-1997	Ford 289, 302, & 351	8560
Includes Register Ring 4.850" and 4.910" Transmission Patterns: T5 and TKO Depth: 6.785" without Motor Plate Motor Plate: .125" Thick		
Fits 164 tooth ring gear		

MCLEOD RACING



McLeod Racing



McLeod Racing

MUSCLE CAR 5 TRANSMISSION

McLeod is proud to introduce the revolutionary Muscle Car 5 Transmission. Its innovative design gives muscle car and hot rod owners the ability to use an overdrive transmission without having to make expensive or annoying modifications.

The McLeod Muscle Car 5 is designed with an exclusive case design that allows for fitment into tight tunnels. Gone are the days of cutting your floorboards to be able to get the benefits of improved fuel economy and lower RPMs that an overdrive transmission provides.



Made in the USA



Muscle Car 5 Transmission

MUSCLE CAR 5 TRANSMISSION

The Muscle Car 5 is designed to handle up to 500 ft/lbs of torque

Ideal gear ratios with a 2.95 1st gear and .63 5th gear

Incredibly strong 8620 forged steel gears

32-spline output shaft for added strength
(same as Turbo 400)

Fully synchronized gears for smooth shifting and quiet operation
Internal rail shifter aides in quick and smooth shifts.

The front cover is designed so it will bolt up to your factory bellhousing

Transmission Application Guide

Make	Part Number	Ratios	1st	2nd	3rd	4th	5th	Input Shaft	Output Shaft
GM	512957		2.95	1.99	1.34	1.00	0.63	1 1/8" X 26	32 Spline
Ford	532957		2.95	1.99	1.34	1.00	0.63	1 1/8" X 26	32 Spline

McLeod is proud to offer a 1 Year/ 12,000 Mile Warranty on all of our Muscle Car 5 Transmissions. The Muscle Car 5 price point, ease of installation and incredible quality make it the best aftermarket transmission available.

TREMEC TRANSMISSIONS

TREMEC Transmissions

McLeod has quickly become known as the one stop shop for all your driveline needs. We are proud to expand our already broad line up by adding TREMEC Transmissions.

TREMEC has long been known for very high quality transmissions for both the street and the track. McLeod brings availability of TREMEC transmissions to our customers backed by our world-class service.

Whether you are looking for a TKO500 all the way through the Magnum XL, McLeod can fill your needs.

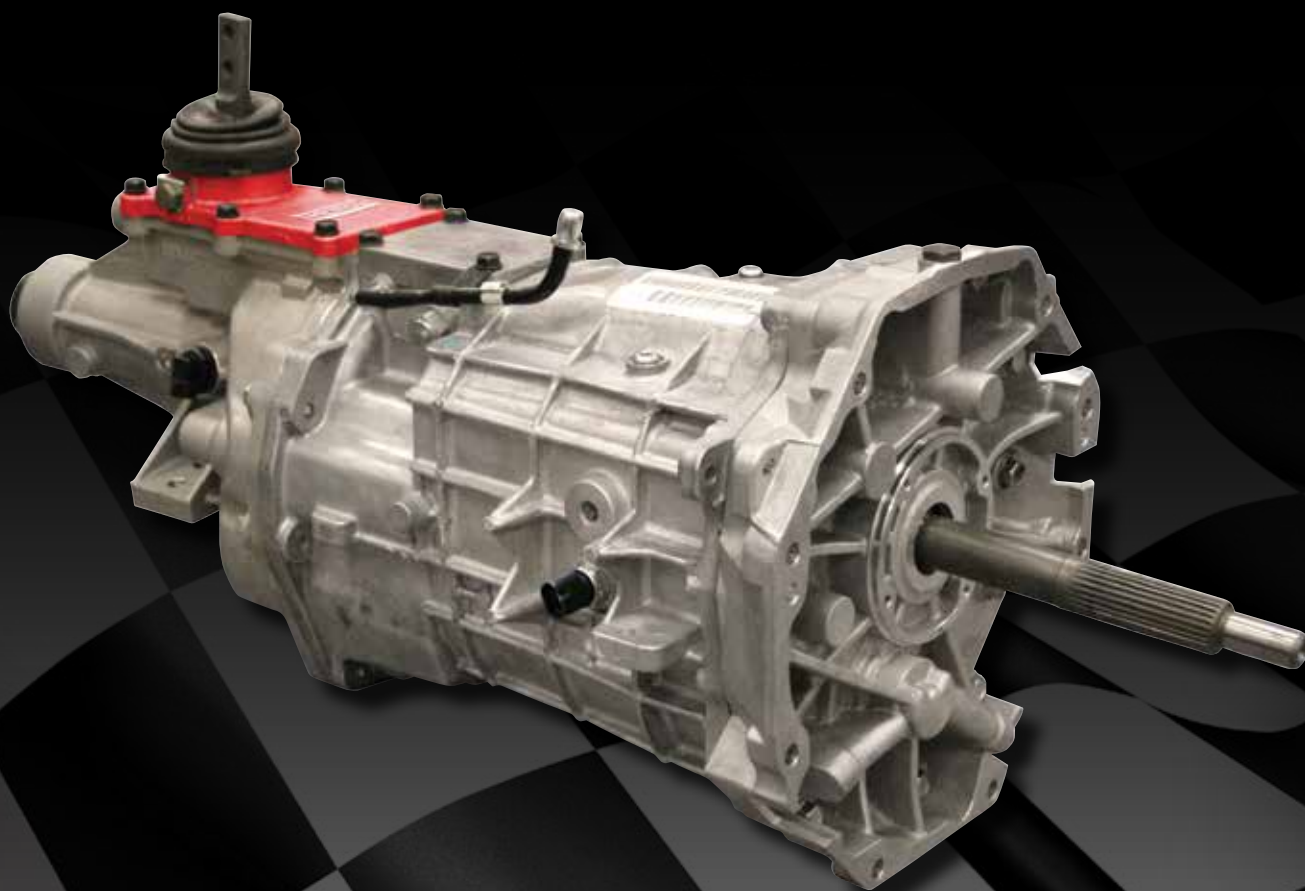

TREMEC Transmissions



CLUTCH 101

The purpose of this section is to help you choose the proper McLeod Clutch, answer basic installation questions, help with troubleshooting current clutch issues and other important topics.

Please remember that this section is for reference only. Your vehicle is unique. The way you drive it is unique. **specific questions about your application please email us at info@mcleodclutch.com or call our Tech Line at 714-690-9668.**

How Do I Choose The Best McLeod Clutch Set-Up For My Vehicle?

Your vehicle and the way you intend to use it are important factors. We offer a full range of clutches so that you can make the best choice for your needs. **offer a full range of clutches so that you can make the best choice for your needs.**

Here are some important factors to keep in mind when trying to choose a McLeod clutch kit.

1. You will need to know what year, make model and engine size of your vehicle.
2. The diameter and spline on the input shaft of the transmission will need to be known if the transmission is not the stock trans.
3. Is your engine stock or what modifications have you made? Knowing the HP and the torque of the engine will help you make a better choice.
4. Will you be using stock tires or something more aggressive? The more aggressive the tire – the more clutch that is needed.
5. How do you intend to drive the vehicle? Some of our clutches are designed for street use only while others are designed for street and occasional track use. Of course, we have race only units also. Be sure to match the recommended use of the clutch you choose to the way you will be using it.
6. Will the vehicle be used for towing?
7. Has the weight of the vehicle been significantly increased?

Here is a quick reference guide for our clutch kits that can be used on the street. Be sure to consult your specific application for specific holding power and use.

Street Pro	Up To 400 HP ⁽¹⁾	Street Use Only	Street Tires Only
Super Street Pro	Up To 550 HP ⁽¹⁾	Street/Track ⁽²⁾	Street/Drag Radials Tires Only
RST Street Twin	Up To 800 HP ⁽¹⁾	Street Use Only	Street Tires Only
RXT Street Twin	Up To 1000 HP ⁽¹⁾	Street/Track ⁽²⁾	Street/Drag Radials Tires Only
Original Street Twin	Up To 1200 HP ⁽¹⁾	Street/Track ⁽²⁾	Street/Drag Radials Tires Only

Footnotes:

1. Refer to the specific clutch part number for specific holding power
2. These clutches are designed for occasional track use. Full race clutches can be found in our racing section.

General Guidelines For Installing A McLeod Clutch

1. Before replacing your old clutch determine the cause of its failure. If anything but normal wear caused your current clutch to fail then you can bet it will cause your new clutch to fail.
2. If oil is present on your old clutch, do the repairs necessary to ensure oil will not get on your new clutch. Oil will ruin your new clutch.
3. The best reference guide for replacing your clutch is the factory service manual for the specific year, make and model of your car.
4. Both the pressure plate and disc should be replaced together at the same time. They work and wear together. Never put a new disc with an old pressure plate.
5. Resurfacing the flywheel is a must. Be sure it is machined to the original factory specifications. Failure to do so will result in a new clutch that doesn't function correctly and or premature wear.
6. Clean the friction surface of both the flywheel and pressure plate with brake cleaner. Be sure there are no traces of oil or grease on either surface.
7. Inspect the input shaft on the transmission. Be sure the new disc slides smoothly on the splines. Be sure to inspect the shaft for any abnormal wear such as twisting, burring, broken splines and any other abnormalities.
8. If applicable, be sure to replace the pilot bushing and throwout bearing.
9. Use the proper clutch alignment tool.
10. Ensure that only the proper bolts, washers, dowels and other application specific fasteners are used.
11. Using a star pattern, torque all flywheel and pressure plate bolts to manufacturer's specs.
12. Properly adjust pedal freeplay if applicable to your vehicle. Failure to do so will result in premature clutch wear and or faulty operation and performance of your new clutch.

CLUTCH TROUBLESHOOTING

Troubleshooting - Malfunctions

I. Melted Or Heavily Worn Clutch Levers (fingers) – T.O. Bearing May Or May Not Be Burnt Up.

- A. T.O. Bearing adjusted too close.
- B. Pressure in pressure plate too much for clutch linkage.
- C. Driver constantly riding clutch pedal.
- D. If one or two fingers show excessive wear while the other doesn't, this indicates probability of factory maladjustment.
- E. Bent or cracked fork

II. Levers Bent Sideways Or Top Of Pressure Plate Badly Scarred.

- A. Engine started before transmission was installed, causing T.O. Bearing and fork to be sucked into pressure plate, resulting in untold amount of damage.
- B. If levers are bent down, pressure plate has been bottomed and gone beyond the stopping point.

III. New Units Burned Up.

- A. Unit may be soaked with engine or transmission fluids.
- B. T.O. Bearing misadjusted.
- C. Unit with a mis-installed disc in backwards, improper bolts-lock washers used on some units that don't require them.
- D. Misapplication due to wrong rear end gears for height of tire or height of tire to weight of car or combination of all three.
- E. Improper T.O. Bearing.

IV. Disc Problems

- A. Facing Missing On Outside Portion Of Disc.
 - 1. Usually just worn out or burnt facings.
 - 2. Sometimes pilot bearing or main drive bad, allowing for banging of disc against side of clutch.
- B. Loose Hub Springs.
 - 1. These springs are designed to take torque; after use they will become looser than when new. This presents no problem unless the spring starts to wear the drive plate or back plate at the windows of the disc.
 - 2. Some designs of plates on the market have springs too weak for most high performance cars. In these cases the springs will fly out of the disc, though the disc will still look good.
 - 3. Center of disc breaks out.
 - a) If the hub and the two plates are still riveted together, but the plate, which the facings are riveted to, is broken out, then you have a misalignment in the transmission. This can be due to a pilot bushing gone bad or just "gone".
 - b) If the hub comes out and the two plates are not riveted together, then the factory did not crush the rivets quite enough.
 - c) Clutch chatter (See General Information).

Troubleshooting - Malfunctions (continued)

V. Bellhousings

A. Out Of Parallel.

1. In order for a clutch, transmission and related parts to function properly the bellhousing must have two surfaces parallel to each other. One is where the bellhousing bolts to the motor. Where the transmission bolts to the bellhousing is the other. To check this, use a dial indicator with a magnetic base. Attach the base to crankshaft and indicator to (top) or transmission mating surface. Turn flywheel and mark the surface with something you can read (chalk, magic marker, etc.). Maximum run-out is $+.005$ to $-.005$.
2. To correct out of parallel; take bellhousing to someone that does blanchard grinding (most steel flame cutter shops have one). Place the engine surface down on the table and have them grind the transmission-mating surface to bring it into parallel.

B. Center Hole Or Bore Out Of Alignment.

1. If the center bore doesn't run true to the center of the crank or pilot bushing, the clutch disc will suffer and possibly affect the transmission front bearing too. Erratic clutch engagement and disengagement can occur. Sometimes the center of the disc will break completely out if this problem is not corrected.
2. To check alignment in the car use a dial indicator tool that attaches to the crank with a magnet or use a regular magnet base indicator holder. Once the base is secure, set indicator dial at "0". Slowly move the flywheel and observe the indicator. The maximum we recommend for the housing to be out of alignment is $+.008$ to $-.008$. When watching indicator it is best to mark the center bore in four places then read and record the indicator reading at those four positions. (We recommend the four positions be like a plus sign in math: "+").
3. Correction of bellhousing alignment is usually done with offset dowel pins. Check our dowel pin section for appropriate part # and offset. If your bellhousing is not ours and it runs out of alignment more than $.040$ out on the black, then we recommend you purchase one of our new housings.

CLUTCH FAQ'S

Clutch Frequently Asked Questions

The purpose of this section is to help you choose the proper McLeod Clutch, answer basic installation questions, help with troubleshooting current clutch issues and other important topics.

Please remember that this section is for reference only. Your vehicle is unique. The way you drive it is unique. For specific questions about your application please email us at info@mcleodclutch.com or call our Tech Line at 714-630-3888.

What Can Cause Clutch Chatter?

1. Oil or grease on the clutch facings.
2. Worn or damaged clutch linkage, leaf springs, bushings, mounts, u-joints, cv joints, engine mounts, transmission mounts.
3. A flywheel that has not been resurfaced properly, has hot spots, has excessive run-out and or incorrect flywheel step.
4. Pressure plate or disc that are bent.
5. Defective pressure plate and or disc.
6. An engine that is not tuned properly.
7. A disc that either lacks enough marcel or has no marcel at all.

What Can Cause Clutch Slippage?

1. A clutch assembly that is worn or failing.
2. Oil or grease on friction surfaces.
3. A clutch that is not designed to hold the amount of power being made.
4. A clutch not designed for the type of driving being done i.e. using a clutch designed for the street at the track.
5. Improper clutch adjustment.

What Can Cause Poor Clutch Releasing?

1. Clutch disc binding on input shaft.
2. Worn or damaged or improperly adjusted clutch linkage.
3. Improperly bled or faulty hydraulics.
4. Flywheel improperly surfaced, machined too thin or not resurfaced before new clutch was installed.
5. Damaged or bent pressure plate and or disc.
6. Clutch disc hub hitting the flywheel bolts.
7. Improper clutch disc thickness.
8. Bent input shaft.
9. Damaged or stretched cable.
10. Clutch fork geometry not correct due to deeper than factory bellhousing, flywheel being too thin, ball stud being improperly adjusted.
11. Pilot bushing binding, worn or improperly installed.
12. Throw out bearing collar worn or damaged.

What Can Cause Poor Shifting?

1. Shifter installed improperly or shifter linkage improperly adjusted or damaged.
2. Misaligned bellhousing.
3. Wrong fluid type used in transmission.
4. Worn transmission parts i.e. synchro gears and or bent fork.
5. Pilot bushing worn or binding on input shaft.

Must I Use The Alignment Pins In The Flywheel?

Yes. The pins help to ensure proper alignment of the pressure plate and add strength.

How Long Should A McLeod Clutch Last?

The biggest factors in clutch life are the way it is used and the output of the engine. McLeod Clutches are designed for maximum life but that life can be shortened by using much stickier tires than stock, stop and go driving, track use, tires of larger diameter and other factors that place added stress on the clutch.

What Are Musts When Replacing My Clutch?

1. Change the pilot bearing.
2. Break the clutch in according to the instructions provided.
3. Ensure proper bellhousing alignment.
4. Resurface the flywheel.
5. Inspect the entire clutch system including hydraulics and linkage.

What is the proper break in period?

We would like to see 500-600 miles of stop & go city driving. With no drag racing or dyno tuning. Make sure to drive in stop & go city driving to actuate the clutch 1200 to 1500 times. You can drive the car 600 miles on the interstate and only shift the car 5 or 6 times and not break in the clutch.

HYDRAULICS 101

Formula for Pedal Ratio

Pedal ratio is the ratio of leverage your clutch pedal applies to the master cylinder. To determine the pedal ratio you need to measure the height of the pedal to the pivot point then divide the measurement of the pivot point to the lower arm that controls your rod to the master cylinder.

A = Height Of The Pedal

B = Center To Center

C = Pedal Ratio

A Divided By B Equals C

For Example: 9" Divided By 1.5" Is Equal To A 6 to 1 Pedal Ratio

Credit: Dean Oshiro

If you apply 100 lbs. of pressure to the clutch pedal, 100 lbs. X (6 to 1) = 600 lbs. of pressure. So, if the clutch pedal has been modified from its' original design the pedal ratio is effected drastically. You can now see the pedal ratio is a "multiplier" of the pressure you apply with your foot, because this is the leverage that is applied to the master cylinder.

Now, take this same formula and substitute 2" instead of 1.5" you end up with a 4.5 to 1 ratio. Multiply 4.5 times the 100 lbs. of applied pressure and you get 450 lbs. instead of 600 lbs. That ½" cost you 25 percent of your clutching power. The same thing applies when you shorten the upper measurement.

How to determine your "A" dimension-Hydraulic Bearing

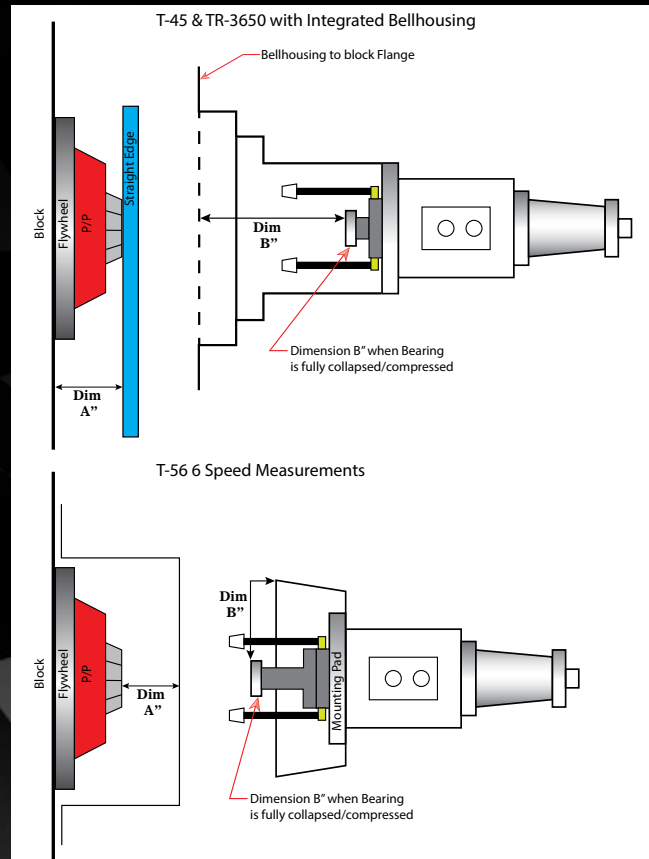
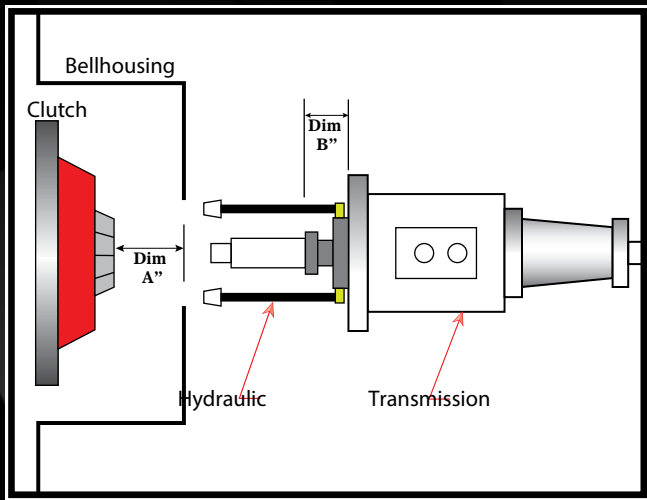

This diagram is to help determine what series hydraulic bearing you need. Before you begin your measurement please make sure to have your entire clutch assembly installed on the back of the motor and torqued down to the factory specifications, this includes Flywheel, Disc, Pressure Plate, Block Plate (if used) and Bellhousing.

If your "A" dimension is less than 3" use the 1300 series bearing. If your "A" dimension is greater than 3" use the 1400 series bearing.

The gap between the face of the bearing and the tip of the pressure plate finger should be between .100" & .200" for proper pressure plate release. To determine if you have the proper clearance subtract your "B" dimension from your "A" dimension and your equation should be within .100" & .200". Anything outside of these parameters requires a piston change on the 1300 series units or an adjustment of the adjustment screw on the 1400 series units to fall back inline to the required parameters.

Note: When Measuring Dimension "A" make sure to measure to the outside mating flange of the bellhousing.

Note: For FORD transmission only customers. When using the Generation IV 1400 series slip on bearing part number 1406-30 your "A" dimension needs to be a minimum of 3.350". If your "A" dimension is less than 3.350" please continue to use our Generation III 1400 series bearing part number 1400-30.

How to properly bleed your new Hydraulic Bearing

Always have the AN -4 line with the bleeder valve at the top when the bearing is properly installed. It is OK to swap the lines on the swivel fittings if necessary. Remember the line with the bleeder valve must be at the top position!

Fill the master cylinder with DOT 3 or DOT4 brake fluid. DO NOT USE SILICONE BASED FLUID or DOT 5 FLUID!! Use of silicone or synthetic fluid will damage the o-rings resulting in leaks and or damage to the assembly.

After the master cylinder is filled, bleed the bearing assembly. Example: Pump the pedal 3 to 4 times, with the bleeder valve open and the end of the opening submerged in a cup partially filled with brake fluid. This will release fluid and air trapped in the system.

Continue the bleeding process until all of the air is removed from the system. Always keep fluid in the master cylinder while performing the bleeding process. Now reach into the cup and tighten the bleeder fitting. Set the cup aside and then be sure to tighten the bleeder valve.

Once the bleeding is complete refill the master cylinder, just don't fill it all the way to the top. The fluid level should be $\frac{1}{2}$ " to $\frac{3}{4}$ " from the top. This will allow room for the brake fluid in the reservoir when the bearing self adjusts. Unlike brakes, the fluid level will rise in the master cylinder, as the clutch wears, not lower.

THROW-OUT BEARING ADJUSTMENT/INFO

SPECIFIC INFORMATION - THROWOUT BEARING & ADJUSTMENT

A. GENERAL MOTORS

If your bellhousing is a 2-piece bellhousing, throwout bearing adjustment is simple: just look up into the bellhousing and adjust the T.O. Bearing off the fingers approximately 1/4". If you have a 360-degree bell housing (one piece), first determine whether or not your T.O. Bearing is of sufficient length and is at the proper pivot angle. To do this, disconnect the adjusting rod so that the fork is free. Move the fork by hand toward the transmission until the T.O. Bearing contacts the clutch fingers.

At this point, check the angle of the fork as it comes out of the bellhousing. It should emerge straight or be slightly angled toward the motor (see Figure 7). If the angle is toward the transmission (Figure 8), you are past center with the bearing and are losing all mechanical advantage (leverage). To correct this problem, install a slightly longer T.O. Bearing (with flat face) or use an adjustable ball stud. Use our T.O. Bearing part no. 1600 first. Then, if it is still too short, use our part no. 1602 bearing or its equivalent (Borg Warner #NI466 or New Departure #CT989S-6) –or their interchanges with local brands carried by your auto parts store.

When using a scattershield and motor plate (Figure 9), it is recommended that you make use of the adjustable ball stud or intermediate T.O. Bearing. To ensure proper adjustment for release on most high performance or drag cars, a hole should be drilled in the bellhousing under the clutch assembly large enough to permit entry of a feeler gauge (Figure 11).

B. ALL-MAKE CARS

When adjusting your clutch with a feeler gauge, push the pedal all the way to the floor-board (or pedal stop). Then, by adjusting the clutch rod, slide the feeler.

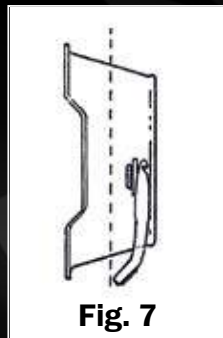

Fig. 7

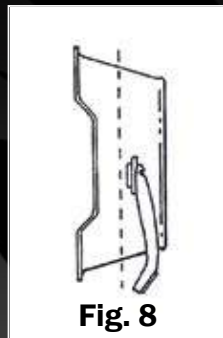

Fig. 8

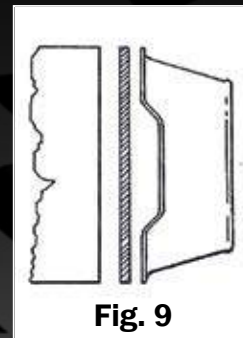

Fig. 9

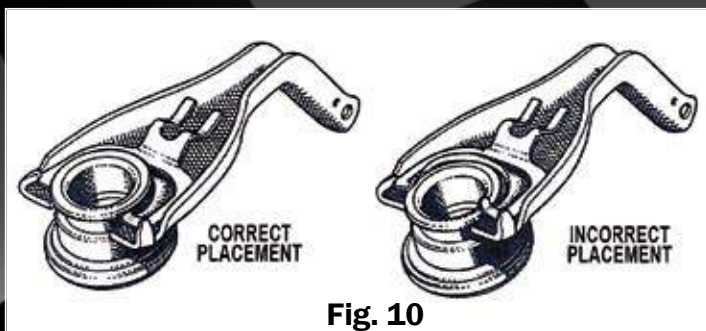

Fig. 10

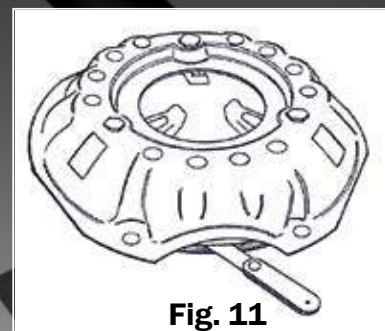

Fig. 11

CLUTCH AND FLYWHEEL REPAIRS

Non Warrantable But Rebuildable Repairs

A. Pressure Plate

1. All pressure plates worn out
2. All pressure plates containing oil, transmission fluid or grease
3. Worn or melted fingers
4. Bent levers
5. Generally torn-up or misused
6. Skinned-up, scraped or disfigured from foreign matter loose in the bellhousing

B. Disc

1. Worn out or burnt up
2. Oil-soaked facings
3. Center split out because of main drive misalignment

C. Flywheel

1. Burned-up face (can be Blanchard-ground)
2. Chipped or ground ring gear teeth (new gear available)
3. Worn heat shields on aluminum flywheel (new ones available)
4. Stripped threads in pressure plate pattern (new pattern can be drilled)

D. Throwout Bearings

1. All bearings installed wrong
2. Bearings burned up
3. All related parts (P/P, Disc, Flywheel) unless factory determines bearing was defective

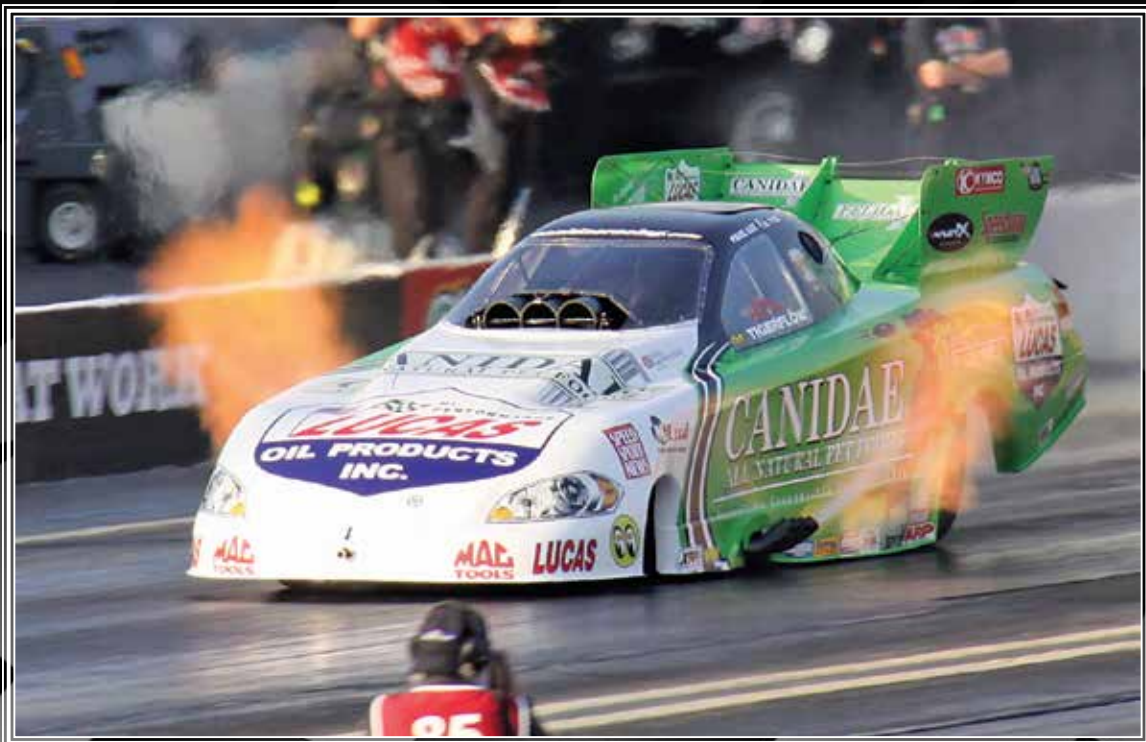

MCLEOD HEADQUARTERS

A look inside McLeod



Located in Southern California, McLeod Racing is proud to build our products right here in the USA.



McLeod Headquarters

MCLEOD HEADQUARTERS



Very few companies in the industry can boast of a 40 year history of continuing innovation.



At McLeod quality is not just a cliché, its a way of doing business.

McLeod Headquarters



In house R&D is an important part of our new product development.



With more combined experience than other clutch companies, McLeod is equipped to give you the best customer service in the industry.

TERMS & POLICIES

Ordering:

1. All orders must be by written purchase order and signed by an authorized agent of the company.
2. Any account not on NET terms must be pre-paid or shipped C.O.D. A company check is not accepted for C.O.D. orders without a prior approval.

Terms:

1. A late charge of 2% (24% annually) will be added to all past due invoices.
2. McLeod Racing LLC reserves the right to terminate any account that fails to make payment when due. Any account that is past due more than 60 days will no longer be considered an active account and all invoices due will be turned over for collection. The debtor will pay collection fees incurred as well as any incurred legal fees.

Freight:

1. All shipping discrepancies must be reported within (3) business days of receipt of shipments.
2. McLeod Racing LLC reserves the right to choose the carrier on all prepaid shipments.

Return Policy:

1. Any unauthorized return will be refused. You must call or use the RGA Request to receive a RGA number (Return Goods Authorization) This number must be displayed on the outside of your package.
2. McLeod Racing LLC will not accept returns over 30 days.
3. McLeod Racing LLC will not issue a cash refund on any merchandise returned. All returns will be used for future orders.
4. There is a 15% restocking fee on accepted returns; this excludes cores and special orders.
5. Special ordered items require 50% deposit and are non-returnable. They also cannot be canceled due to the fault of McLeod Racing LLC or their supplier of said merchandise.
6. Defective merchandise will be exchanged upon receipt of said merchandise.
7. All orders must be inspected upon receipt. Damages should be supported to the carrier immediately when the shipment is received. Damaged goods are the responsibilities of the shipping company and it is the customer's responsibility to make claims with the shipping company when damage occurs.
8. All returns must include a copy of the original invoice or they will be returned. No credit will be issued.
9. Stock adjustments, of the product in "as new" sellable condition, may be no more than 5% of previous years purchase with a 2 for 1 offsetting order. No stock adjustments will be processed In December and or January.

High Performance Parts, Service And Information Excluded From Warranty:

Due to the unusual stress placed on high performance parts, and because of the circumstances under which they are often used, high performance parts are sold without warranty, AS IS WITH ALL FAULTS, and all warranties, expressed or implied, of merchantability, or of fitness for a particular purpose, or otherwise are expressly disclaimed and denied. Seller disclaims all responsibility for consequential, incidental or commercial losses including labor claims and rental vehicles.

Duties:

The duty of McLeod Racing LLC to the customer is strictly contractual and shall in no way exceed the duties accepted herein, and where there appears an ambiguity in the contract language, the same shall be construed to limit the duty of McLeod Racing LLC.

Consent And Jurisdiction:

The parties agree that any dispute arising out of parts, service or information provided by McLeod Racing LLC shall be decided by the courts of the State of California and that no other court shall have jurisdiction over said dispute. McLeod Racing LLC maintains no sales force, service facility or agents outside the State of California.

Emission Control Compliance:

Customers are responsible for emission control compliance (if any) of McLeod Racing LLC engine and/or other components in their locality.



McLeod



Made in the USA

Catalog
P/N 9200120