

EXEDY

CATALOG

Clutch Kit / Cable / Hydraulic /
Fork / Flywheel

2020-2021



EXEDY

EXEDY Globalparts Corporation

FIRST THINGS FIRST

Establish the reason for a replacement clutch being required.

If this is not due to normal usage, then the root cause of the condition must be established and corrected. These causes may include a slipping clutch, oil contamination, misalignment, faulty or incorrectly adjusted clutch release mechanism, faulty engine or gearbox mountings etc...

Already in the Future!

EXEDY[®]

EXEDY Globalparts Corporation



2020-2021 Product Catalog





MAJOR OE CUSTOMERS

JAPAN

Direct transaction clients

Name	JAPAN	
	EXEDY	DYNAX
OEM Customers		
Automotive		
Isuzu Motors	•	
Nissan Motor	•	•
Nissan Diesel Motor	•	
Honda Motor	•	•
Toyota Motor	•	•
Daihatsu Motor	•	
Mazda Motor	•	•
Fuji Heavy Industries	•	•
Mitsubishi Motors	•	•
Hino Motors	•	
Suzuki Motor	•	•
Construction & Industrial Vehicles		
Nissan Motor	•	
Toyota Automatic Loom Works	•	
Kato Works	•	
Kawasaki Heavy Industries	•	•
Tadano	•	
Furukawa	•	•
Kobe Steel	•	•
Komatsu	•	•
Komatsu Forklift	•	•
Konatsu Mec	•	•
Komatsu Est	•	•
TCM	•	•

Name	JAPAN	
	EXEDY	DYNAX
OEM Customers		
Yutani Heavy Industries	•	
Mitsubishi Heavy Industries	•	•
Shin Caterpillar Mitsubishi	•	•
Hitachi Construction Machinery	•	•
Sumitomo Eaton Hydraulics		•
Sumitomo Yale	•	
Agricultural		
Iseki & Co., Ltd	•	•
Ishikawajima Shibaura Machinery	•	
Kubota	•	•
Yanmar Diesel Engine	•	
Mitsubishi Agricultural Machinery	•	
Unit		
Kayaba Industry		•
Nabco		•
Aisin AW		•
Aisin Seiki		•
Jatco	•	•
Aisin AW Seimitsu		•
Toyota Motor Hokkaido		•

UNITED STATES

Name	Japan			U.S.A.		
	EXEDY	DYNAX	DAIKIN CLUTCH	DAIKIN DRIVER/FRAN TM COMPONENTS	MERITOR CLUTCH	DYNAX AMERICA
OEM Customers						
USA						
Automotive						
AAI (Ford Motor)	AAI (Ford/Mazda)			•		
CAMI (GM)	CAMI (GM/Suzuki)				•	•
Ford Motor		•		•		
Freightliner					•	
General Motors				•		
HAM	HAM (Honda)			•		
Kenworth					•	
Mack					•	
M.M.M.A.	M.M.M.A. (Mitsubishi)				•	
Navistar					•	
NMMC	NMMC (Nissan)			•		•
Peterbilt					•	
SIA	SIA (Fuji/Isuzu)			•		
Volvo					•	
Western Star					•	
Construction & Industrial Vehicles						
E-HITACHI	EUCLIK-HATACHI		•			
JI Case		•				
KFI	Komatsu Forklift U.S.A. Inc.	•		•		
KMS	Konatsu Mining Systems		•			
TIEM	Toyota Industrial Equipment Mfg.			•		
Unit						
DANA						•
EUROPE						
Automotive						
BENZ		•				
GM	Gm France	•				
Construction & Industrial Vehicles						
Fiat hitachi Excavators		•				
Kawasaki Precision Machinery		•				
Volvo		•				
Komatsu Hanomag A.G.		•				
Unit						
VOITH		•				
ZF		•				
ASIA						
Automotive						
BEML	Bharat Earth Movers Ltd.		•			
Hyundai Motor		•	•			
Construction & Industrial Vehicles						
Daewoo Heavy Industries			•			
Hyundai Heavy Industries			•			
Komatsu Changlin			•			

Distributors/Agents are not listed
(As of July 1, 1999)



TABLE OF CONTENTS

SECTION 1

TERMS AND CONDITIONS OF SALE.....	4-5
COMPANY PROFILE.....	6
BUSSINESS LINE-UP	7
WORLDWIDE NETWORK.....	8
PARTICIPATION IN EXHIBITIONS.....	9
AWARDS.....	10-11
TIPS FOR INSTALLING CLUTCH.....	12
FUNCTION OF A CLUTCH	13-14
ABBREVIATION OF THE SIZE.....	15
CLASSIFICATION OF CLUTCH COVER	16
CLASSIFICATION OF CLUTCH DISC	17
BENCH TESTING	18-19
EXEDY CUSTOMER PORTAL	20
EXEDY APP	21
PRODUCT LEGEND.....	22

1

SECTION 2

VEHICLE APPLICATIONS GUIDE	23
----------------------------------	----

2

SECTION 3

MEDIUM DUTY TRUCK APPLICATIONS GUIDE.....	163
---	-----

3

SECTION 4

CONVERSIONS METRIC TO INCHES	181
------------------------------------	-----

4

SECTION 5

CLUTCH INSTALLATION INSTRUCTIONS.....	185
---------------------------------------	-----

5



EXEDY Globalparts Corporation

www.exedyusa.com

1

1. All orders accepted by, and goods/products supplied by, EXEDY GLOBALPARTS CORPORATION, hereafter referred to as the Company, are subject to the following Terms and Conditions of Sale. Any exceptions and/or variations must be specifically agreed to in writing by both parties.
- 2a. Manufacturers' Names, Part Numbers, Symbols or any other references appearing in the Company's listing and/or on the Company Packaging, are used for reference purposes only and in no way indicate the goods/products are made by, for, and/or guaranteed by such manufacturers.
- 2b. No partnership, joint venture, or other such association will be deemed created by opening an account with the Company. Neither party is the agent of the other, and neither party shall represent itself as an agent, officer or principal of the other for any purpose, including, without limitation, entering into any commitment, agreement or other obligation. Purchasing product from the Company does not in any way imply that the customer is an appointed sole Distributor or an **exclusive Distributor of the Company's products**.
3. All data, applications and/or interchanges, contained in the Company's listing and catalog/publications electronic lookup systems have been compiled as carefully as possible from reliable and official sources of information available at the time of publishing and appears as a **general guide only**. The information contained is correct to the best of the Company's knowledge and belief. **However, the Company cannot, and will not, assume any responsibility for possible errors contained in the publications.** Correct selection of goods/products is the responsibility of the Distributor.
- 4a. Standard OEM replacement clutch kits are guaranteed for a period of twelve (12) months or 20,000 miles, whichever ever occurs first, against manufacturers defect. OEM Replacement clutch kits and Automatic Transmission kits used in performance applications are not covered by any warranty.
- 4b. For warranty information on sports and performance clutch products, please refer to EXEDY sports clutch catalog. Sports and performance clutch products do not carry a 12 month or 20,000 mile warranty.
- 4c. All goods/products supplied by the Company are warranted against faulty material and/or workmanship. Warranty does not apply if maltreatment, damage caused by collision or incorrect fitting exists. Warranty does not apply when the goods/products sold are fitted to a vehicle used for speed trials, racing, time trials, commercial and off road vehicles unless specified for that use in the Company's publications.
- 4d. When the Company's clutch covers, clutch discs, or bearings are repackaged with another manufacturer's parts all warranties are void.
- 4e. Standard clutch kits and/or clutch components fitted to modified vehicle and/or clutch components that have been modified to Heavy Duty Specifications and/or any other specification/non-original conversions; Clutch disc and/or clutch disc friction material that have been altered are not covered by any warranty issued by the Company.
- 4f. Standard clutch kits claims will be rejected where clutch kits and/or clutch components have been fitted to incorrect or unlisted applications. Flywheel must be resurfaced/machined to OEM specifications before new clutch kit is fitted otherwise warranty will be void.
- 4g. All clutch kits and components must be installed per OEM factory service procedures.

***WARNING:** Do not use EXEDY clutch products in any situation where engine RPM's may exceed manufacturer's specifications. Pressure plate can explode unexpectedly causing serious injury or death to vehicle occupants and bystanders. Clutch cover and bell housing will not protect against exploding pressure plate. Refer to the Application Catalog for correct fitting. For sports and performance applications, please refer to the EXEDY Sports and Performance Publication.

CLAIM/WARRANTY PROCEDURES

- 5a. Any goods/products deemed by the Distributor to be faulty must contact our **Technical Support Department** at **800-346-6091** or by email: **TechSupport@exedyusa.com** to obtain an Inspection Request Form. A completed Inspection Request Form shall be returned for review, if approved a RGA number will be issued. The goods/products being returned must be sent to us **freight prepaid**.
- 5b. No Claim Credit will be issued until the said goods/products have been tested and deemed faulty by the Company.
- 5c. The Company will not pay any claim for goods/products repaired by the Customer and/or claims sight unseen.
- 5d. It is the responsibility of the Company's Distributor to advise their customer on all aspects of this warranty and/or warranty procedures on any claim.
- 5e. No Claim/Warranty will be given for NON-Kit OE replacement components and/or hydraulic components.

RETURN FOR CREDIT PROCEDURE

- 6a. Goods/Products and packaging must be in resalable condition.
- 6b. Freight must be prepaid by Distributor.
- 6c. All returns must be pre-approved by Company, any returns that arrive without pre-approval will be returned to sender.
- 6d. To obtain a RGA number, contact our **Returns Department** at **800-346-6091** or **returns@exedyusa.com**.
- 6e. A reason for the return of goods/products must be indicated at the time of return and be approved by the Company in advance. (Refer to 5a).
- 6f. Stock Adjustments/Returns: Will be at the discretion of the Company.
- 6g. Returns will be subject to 20% restock fee.
- 6h. All special ordered goods/products will not be accepted back for credit.
- 6i. Returns will not be accepted after thirty (30) days from issue date of RGA (Return Goods Authorization).

FREIGHT/INSURANCE

Only applicable for EXEDY Globalparts Corporation Authorized Distributors

- 7a. Standard Clutch Kit orders over \$1,000 (US Dollars) will be shipped freight prepaid within the Continental United States. Component orders over \$7,500 (US Dollars) will be shipped freight prepaid within the Continental United States. **NOTE:** Sports and performance kits and products are excluded. (No free shipping on sports products) Please refer to special conditions if negotiated below. Drop shipment requests for orders under \$300 (US Dollars) there will be an additional service fee applied. Freight will also be added.
- 7b. Insurance is not included in the freight charge. Insurance, if required, is the responsibility of the Distributor and must be arranged prior to dispatch of goods/products.
- 7c. Distributors wishing to request another freight company and/or method, other than the one used by the Company, must make arrangements prior to dispatch of goods/products. All costs incurred and insurance, if required, are the responsibility of the Distributor.
- 7d. Any claims for damaged goods/products or shortages in transit must be filed with the carrier at the time of delivery. All claims listed must be identified on the delivery receipt. Any claim not identified on delivery receipt will not be the responsibility of the Company. Any claims of damaged/shortage must be reported to the Company within 2 business days (after receipt of delivery), the signed delivery receipt showing the damage/shortage must accompany this claim.

COPYRIGHT/TRADEMARK INFRINGEMENT

- 8a. "EXEDY" and/or its Logos are Registered Trademarks with the United States Patent & Trademark Office, (Registration No. 76482354, WIPO No. 1046491).
- 8b. Trademark infringement is a serious violation of Federal law, subject to severe civil penalties; including, without limitation, injunctive relief, destruction of the infringing products, recovery of the infringer's profits and any actual damages caused by the infringement.
- 8c. Distributor is not allowed to use EXEDY" and/or its Logos, without expressed written consent.

Please draw our attention to any errors, omissions and anomalies. It is the responsibility of the Company's Distributor to advise their staff and customers of the above terms and conditions of sales.

All Terms and Conditions stated above are effective October 1, 2014 and supersede any other Terms and Conditions. EXEDY reserves the right to update or amend these Terms and Conditions at any time without prior notice.

1

- 1950 Incorporated as DAIKIN Manufacturing Co., Ltd.
- 1973 Established DYNAX Corporation in Hokkaido.
- 1975 Ueno Division Started in Mie.
- 1977 Established DAIKIN Clutch U.S.A., Inc.(present EGP)
- 1981 Kawagoe plant started in Saitama.
- 1995 Changed Corporate name from “Daikin Mfg. Co., Ltd.” to “EXEDY Corporation”
- 1997 Listed on 1st Section of Tokyo Stock Exchange.
- 1999 **QS-9000 & ISO9001** Certified in March
- 2000 ISO14001 Certified in June
- 2001 Strategic Alliance with Aisin Seiki Co., Ltd.
- 2004 **ISO/TS16949** Certified in June
- 2012 New headquarter building is complete



Expectation of the new head building

Established

July 1950

Net Sales
(For the 2016 Fiscal Year)
Exchange Rate: \$1= ¥110.30

¥266 Billion \$2.41 Billion
(EXEDY Group)
¥119 Billion \$1.07 Billion
(EXEDY Corp.)

Number of Employees
(As of March 31, 2017)
*Includes an average taken for temporary employees

18,040 (EXEDY Group)
3,894 (EXEDY Corp.)

Annual Sales Growth

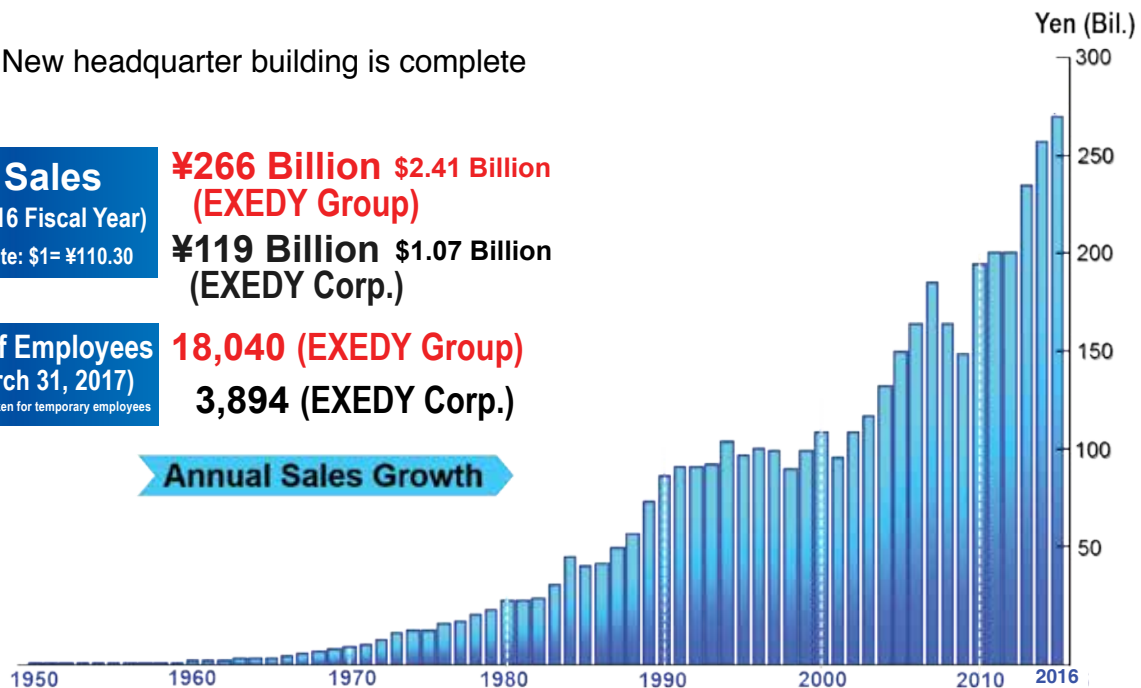

The leading company of drivetrain components

EXEDY is a general drivetrain systems manufacturer with a main focus on automotive clutches and torque converters, managing from development to production. With the core technologies specializing in friction, vibration and fluid. EXEDY's products have been highly recognized by car manufacturers around the world and widely adopted as a genuine brand. EXEDY continues to hold a large share in both domestic and international markets, establishing 42 group companies covering 23 countries worldwide.

Core Technology

Friction

Development of the highest quality friction material that can demonstrate the world's top level performance.

VIBRATION

Development of the most efficient Damper that can absorb vibration from the engine.

FLUID DYNAMICS

Development of the most efficient Torque Converter grounded on the analysis of the fluid dynamics inside.

AT products

EXEDY manufactures Torque Converters and Clutch Packs, providing today's drivers with a smooth and comfortable ride. The Super Squashed Torque Converter with high efficiency grounded on Hydro-dynamics has been marking great advances in the American and Chinese automotive markets.



Super Squashed Torque Converter



Lock-up Damper



Clutch Pack



Paper Disc



Clutch for Passenger Vehicles



Clutch for Large-sized Commercial-Vehicles



Sports Clutch

MT products

The EXEDY group companies manufacture clutch covers and clutch disc assemblies around the world. EXEDY also develops dampers with high efficient noise/vibration control and high performance motor sports clutches.

TS products

EXEDY supplies uncompromising high quality products with virtually made-to-order, multi-item, small-sized production. EXEDY's power shift transmission for construction and industrial vehicles powerfully support Japanese key industries.



Power Shift Transmission

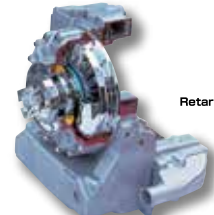

Retarder

Motorcycle products

EXEDY manufactures motorcycle clutches in the expanding markets of Southeast Asia. Utilizing the expertise accumulated in automotive clutches, EXEDY group companies in the region produce and supply Wet-type Multi-Plate Clutches and One-Way Clutches for Motorcycles.



Diaphragm Spring Type Wet Multiplate Clutch



Coil Spring Type Wet Multiplate Clutch



Dry type centrifugal clutch with pulley



Wet Centrifugal Clutch



One-Way Clutch



Dry multi-plate clutch

1

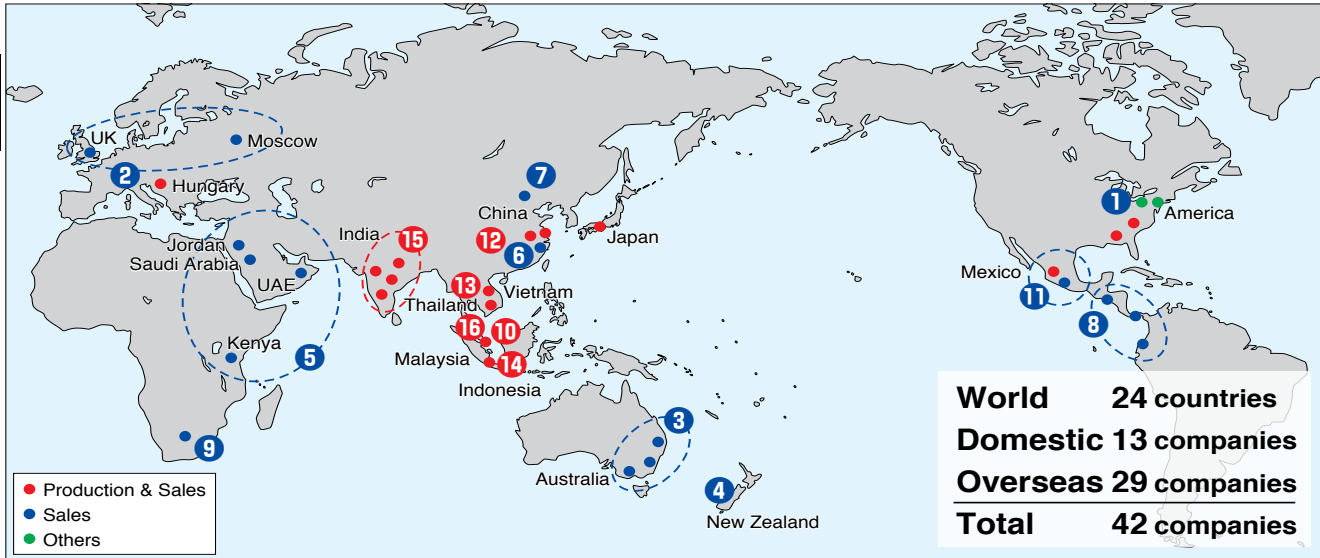

Aftermarket Group

① EXEDY Globalparts Corporation Michigan, U.S.A.



8601 Haggerty Road S.,
Belleville, MI 48111, U.S.A.
TEL:1-734-397-3333
FAX:1-734-397-7300

② EXEDY Clutch Europe Ltd. Cheshire, U.K.



Unit2, Rokeby Court,
Manor Park,
Runcorn,Cheshire,
WA7 1RW, U.K.
TEL:44-1928-571850
FAX:44-1928-571852

③ EXEDY Australia Pty.Ltd. Melbourne, Australia



21 Fiveways Boulevard,
Keysborough,
Victoria 3173, AUSTRALIA.
TEL:61-3-9701-5556
FAX:61-3-9701-5684

④ EXEDY New Zealand Ltd. (Auckland, New Zealand)



151 Wairau Road Glenfield
Auckland,
NEW ZEALAND
TEL:64-9-444-0901
FAX:64-9-444-0903

⑤ EXEDY Middle East FzCO (Dubai, U.A.E.)



P.O.BOX 18199, Warehouse
No. ZE5 & ZE6 Jebel Ali Free
Zone, Jebel Ali Dubai,
U.A.E.
TEL:971-4-883-2244
FAX:971-4-883-2500

⑥ EXEDY Guangzhou Co., Ltd. (Guangzhou, China)



No.406 E-Area, Longfu Car
Accessories Centre, Hengfu
Road, Guangzhou, CHINA
TEL:86-20-83489166
FAX:86-20-83489370

⑦ EXEDY Beijing Co., Ltd. (Beijing, China)



Parts wholesale hall
No.3063-3065,
Wufangtianya Auto
Accessories&Parts Market ,
Chaoyang district, Beijing,
CHINA
TEL:86-10-67297987

⑧ EXEDY Latin America S.A.

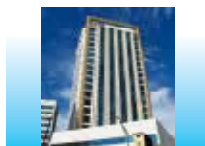

P.H. World Trade Center,
Piso 3, Oficina 303
Marbella, Panama City,
Republic of Panama
TEL:507-395-7122/7123
FAX:507-395-7124

⑨ EXEDY SOUTH AFRICA (PTY) LTD



49 Loper Avenue, Airport,
Kempton Park, South Africa

⑩ EXEDY SINGAPORE PTE. LTD.



37 Ubi Crescent, Singapore
408586
TEL:65-6749-1395
FAX:65-6742-6936

⑪ EXEDY Mexico Aftermarket Sales, S.A. de C.V.



Via Adolfo Lopez Mateos 9,
Col. Lomas Verdes,
Naucalpan, Edo. De
Mexico, 53120,
Mexico
TEL:52-55-5572-5127

⑫ EXEDY Chongqing Co., Ltd. (Chongqing, China)



No.4 Longjing Road, North
New Economic
Development Zone,
Chongqing, 401142, CHINA
TEL:86-23-62924439
FAX:86-23-62900348

⑬ EXEDY (Thailand) Co.,Ltd. (Chonburi, Thailand)



700/316 Moo 6, Bangna-
Trad Road, Tumbon Don
Hua Roh, Amphur Muang,
Chonburi 20000,
THAILAND.
TEL:66-38-214-423
FAX:66-38-214-422

⑭ P.T.EXEDY Manufacturing Indonesia (Karawang, Indonesia)



Jl. Permata V Lot EE 3
Kawasan Industri KIIC
Karawang 41361 Jawa
Barat, Indonesia
TEL:62-21-89114666
FAX:62-21-89114568

⑮ EXEDY India Ltd. (Greater Noida, India)



Plot No.L-4, M.I.D.C.
Industrial Area,
Chikalthana, Aurangabad
431 210, Maharashtra, not
M.H.INDIA
TEL:91-240-2484014
FAX:91-240-2484403

⑯ EXEDY India Ltd. (Aurangabad, India)



Plot No.9, Udyog Kendra
Industrial Area, Greater
Noida, 201 304, U.P., INDIA
TEL:91-750-3131000
FAX:91-120-2397086

⑰ EXEDY (Malaysia) Sdn.Bhd. (Negeri Sembilan, Malaysia)



PT 16748, Jalan Permata
1/5, Arab-Malaysian
Industrial Park 71800 Nilai,
Negeri Sembilan,
MALAYSIA
TEL:60-6-7992988
FAX:60-6-7996388

TOKYO AUTO SALON 2019



JAPAN

SEMA SHOW 2018



LAS VEGAS

PERFORMANCE RACING INDUSTRY 2018



INDIANAPOLIS

ATRA 2016



LAS VEGAS

PAACE AUTOMECHANIKA 2018



MEXICO

AUTOMECHANIKA DUBAI 2015



DUBAI

Winner of the Daihatsu Special Quality Awards 2012

1



President Ina

President Shimizu

13 Consecutive Years

April 16, 2013

Daihatsu Motor Co.
President Koichi Ina (Left)



2001	2002	2003	2004	2005	2006	2007	2008	2009	2010	2011	2012
1/200	1/207	2/199	2/195	2/196	2/206	2/356	2/338	2/291	1/258	2/289	2/300

**2012
2/300**

Jatco Supplier Award 2012

Global Technical Innovation Award
Development of High Performance and Low Cost Torque Converter for CVT8



President Shimizu

President Hata



July 31, 2013

Quality: Thailand

ISUZU Engine Manufacturing Co., (Tailandia) Ltd.
Best in Quality Award



Four out of 86 companies received this award



April 2010

1

Nissan Global Supplier Award 2011

Commemorated in regards to our next generation CVT torque converter for small and light applications.



Nissan Motor Co. Chief Executive Officer Toshiyuki Shiga (left) and EXEDY President Haruo Shimizu.



Commemorated Award and Certificate

GM Supplier Award for Quality in 2014



Daimler Supplier Award 2008

Best Supplier Power Train



Dr. Dieter Zetsche, Chairman & Mr. Haruo Shimizu



14 companies

Supplier of the Year 2009



HYUNDAI KIA MOTORS
 Award of Appreciation



① Check for Clutch Disc Appearance

Be sure to handle the clutch carefully and wear clean cotton work globes. Check the clutch disc that is being installed to confirm that the facing is not chipped and there are no scratches on the spline hub teeth.



② Check for the Movement of Clutch

If no problem is found, fit the clutch disc onto the transmission's top shaft and confirm that it moves smoothly.



③ Apply the Grease to Spline Hub Teeth

After confirming that the clutch disc moves smoothly, remove it from the top shaft and use brush to apply the grease to spline hub teeth.



④ Apply the Grease to Top Shaft

Also, apply the grease to the top shaft teeth.



⑤ Remove Excess Grease

Fit the clutch disc back onto the top shaft and wipe away the excess grease. Excess grease could fly off and cause a juddering noise or slipping problems.

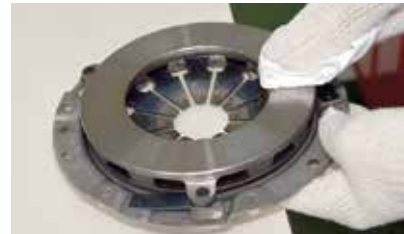

⑥ Check for Clutch Cover Appearance

Confirm there are no scratches or other defects on the friction surfaces of the pressure plate. If there are no problems, use a cleaner to de-grease the pressure plate friction's surfaces.



⑦ Installing to Fly Wheel

When installing the clutch, use an alignment tool to settle the clutch disc. Align the clutch cover with the flywheel's down pins, and temporarily tighten at least three diagonally opposed bolt.

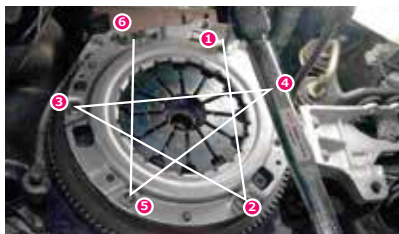

⑧ Tighten Diagonally

Before finishing tightening the bolt, re-confirm that the clutch disc is centered. Now, tighten the bolt to the specified torque, alternating between diagonally opposed positions. Do not use impact wrench to tighten the bolt. Differences on diaphragm's height can cause juddering noise or other problems.

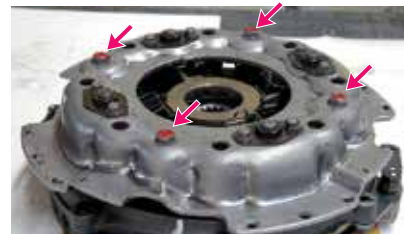

⑨ Remove Temporary Tightening Part

Clutch cover for middle size and larger vehicles are fitted with red bolts, red wires and red plates for temporary assembly. After installing the clutch, be sure to remove them.
※Check p○,○ for your information.



⑩ Reinstalling the Transmission

When reassembling the transmission, position it so that crankshaft and the top shaft are aligned in straight line. While aligning the teeth, carefully insert the top shaft all the way into the clutch disc spline in a single motion.

Stopping midway or forcing the top shaft in could dent spline hub teeth and result in faulty disengagement.

After confirming that the clutch housing is fully contacted with engine's mounting surfaces, tighten the housing mounting bolt to the specified torque alternating between diagonally opposed positions.

Do not use impact wrench to tighten the bolts as the top shaft could be shifted off center.

Correct handling and installation will prevent malfunction of clutch.

1. Function of transmitting the torque from the engine to the drivetrain.
2. Smoothly deliver the power from the engine to enable smooth vehicle movement.
3. Perform quietly and to reduce drive-related vibration.
4. Protect the drivetrain when given the inappropriate use. Given the situation, the Exedy clutch will fail when given the inappropriate use in turn to protect the rest of the drivetrain, similar to the function of an electric fuse.

CLUTCH DISENGAGED

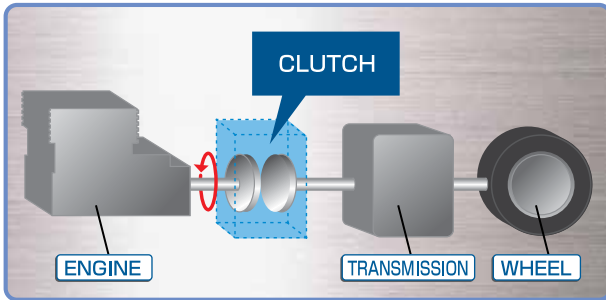

CLUTCH ENGAGED

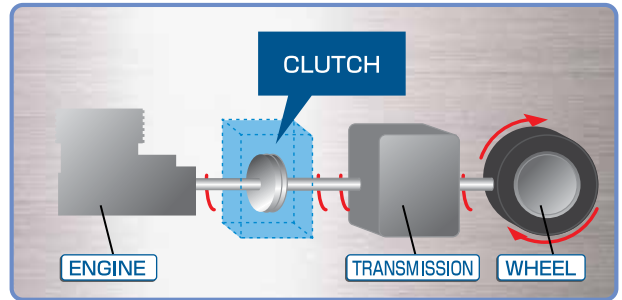

Structure of the drivetrain and the clutch

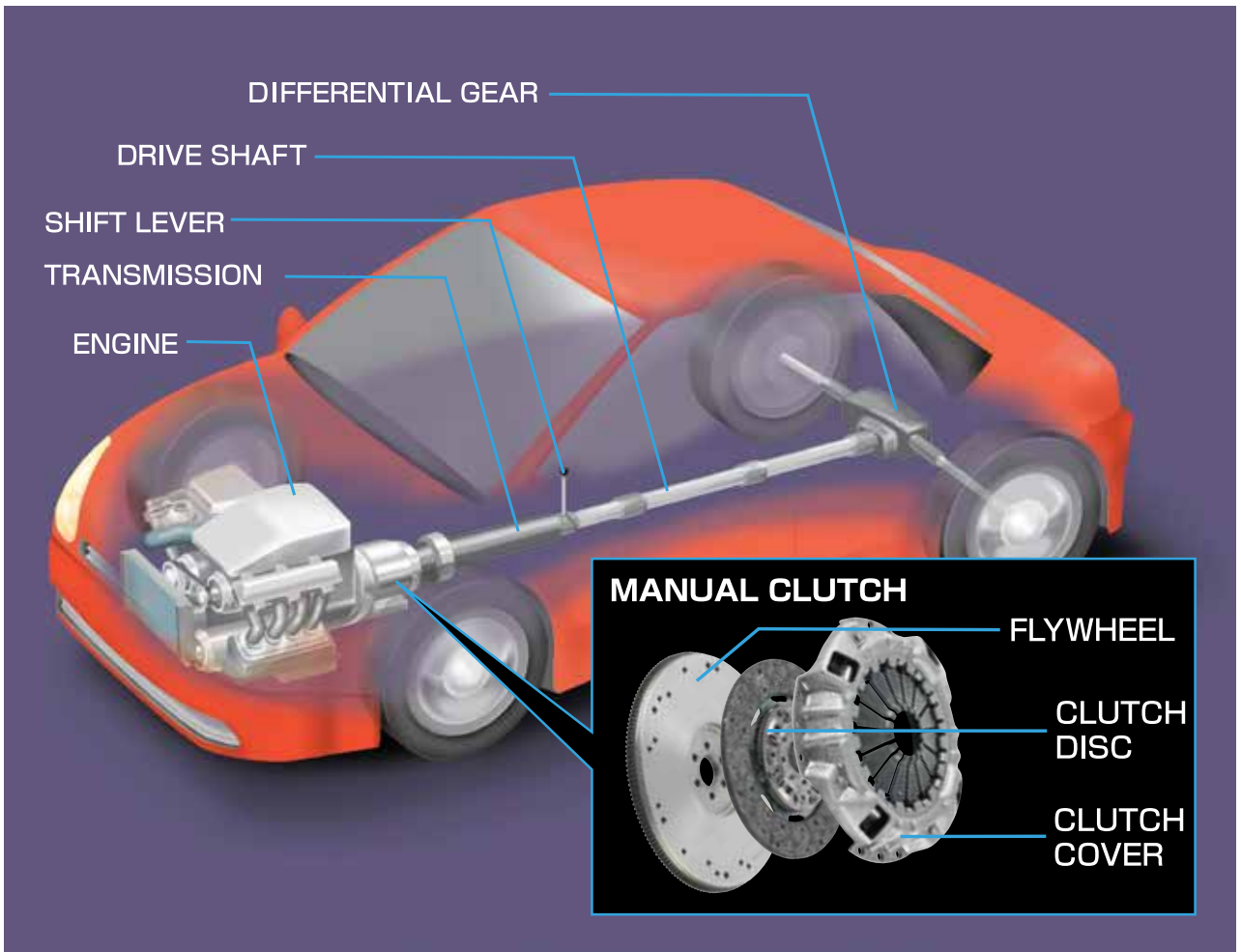

PUSH TYPE MANUAL CLUTCH ASSEMBLY

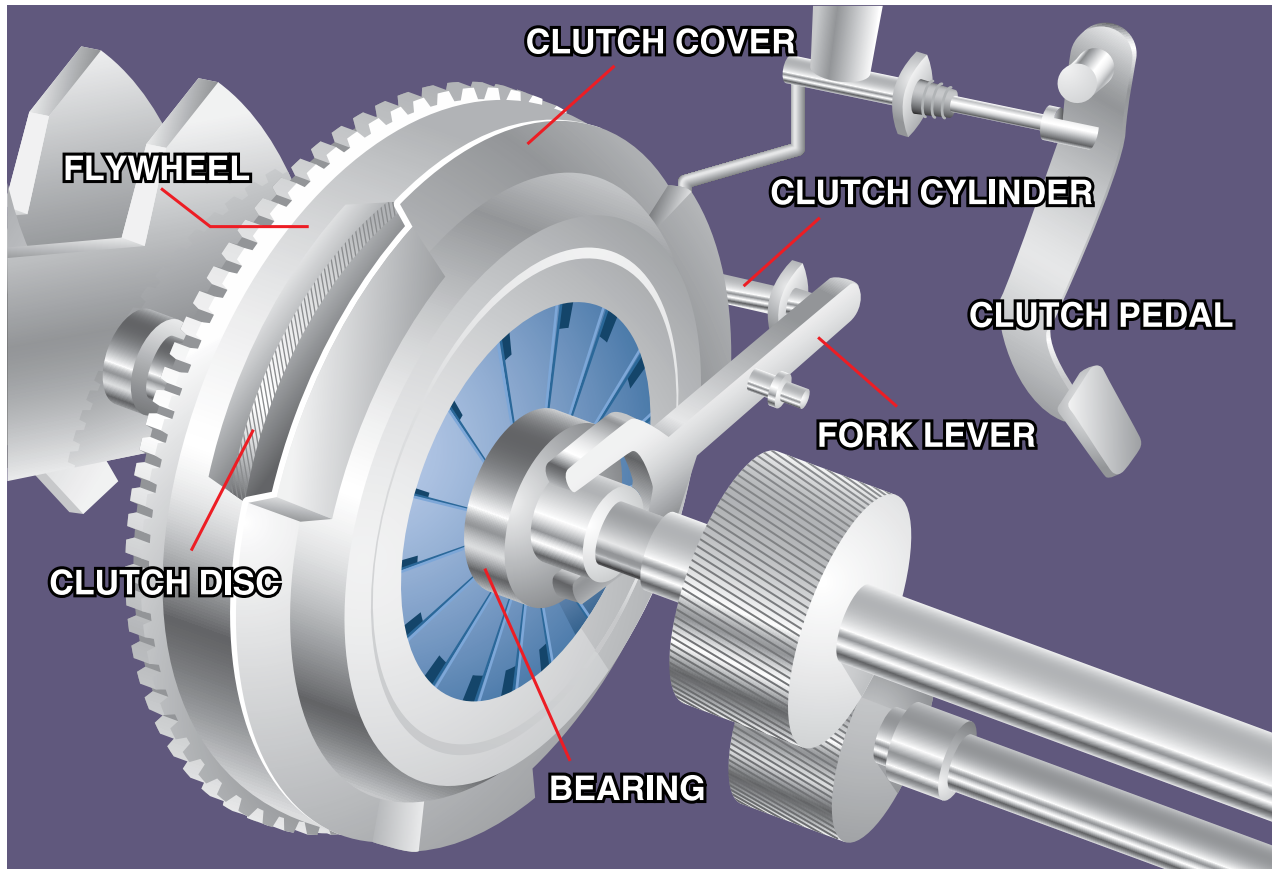

When the clutch pedal is pressed, a cable or hydraulic piston pushes on the release fork, which presses the throw-out bearing against the middle of the diaphragm spring. With the spring pushed, the clutch disc is then disconnected from the rotating flywheel that is attached to the engine. When the pedal is released, the disc will engage contact with the flywheel and transmit the torque from the engine to the rest of the drivetrain.

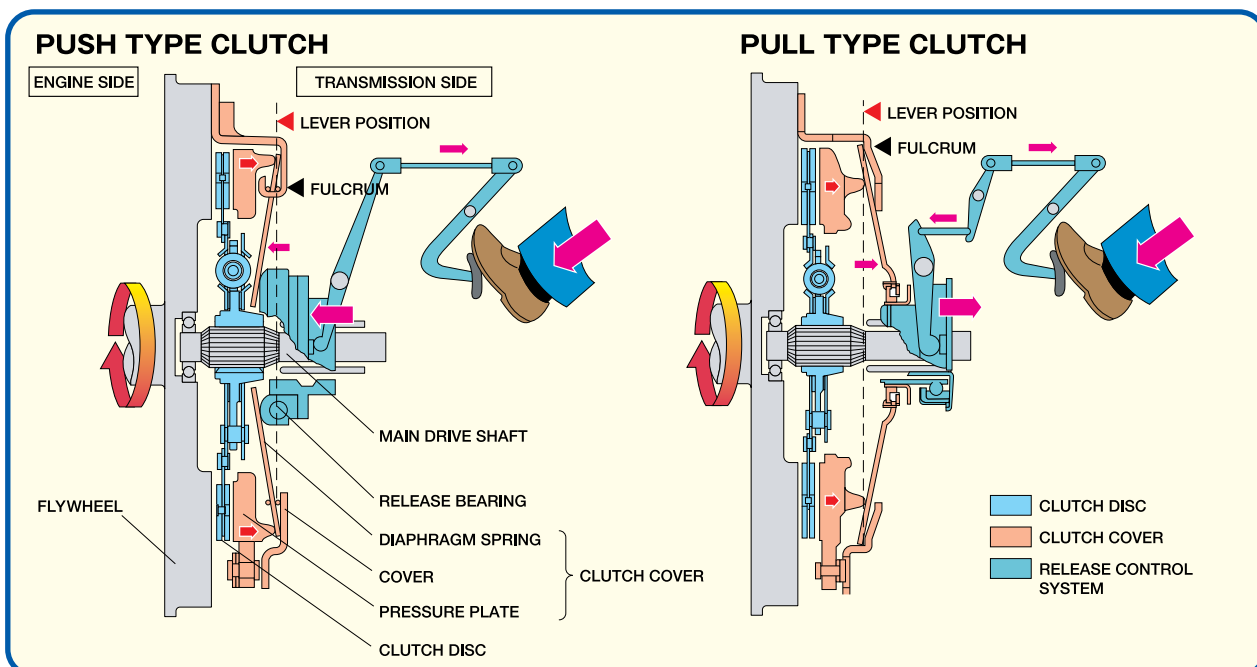

CLUTCH COVER

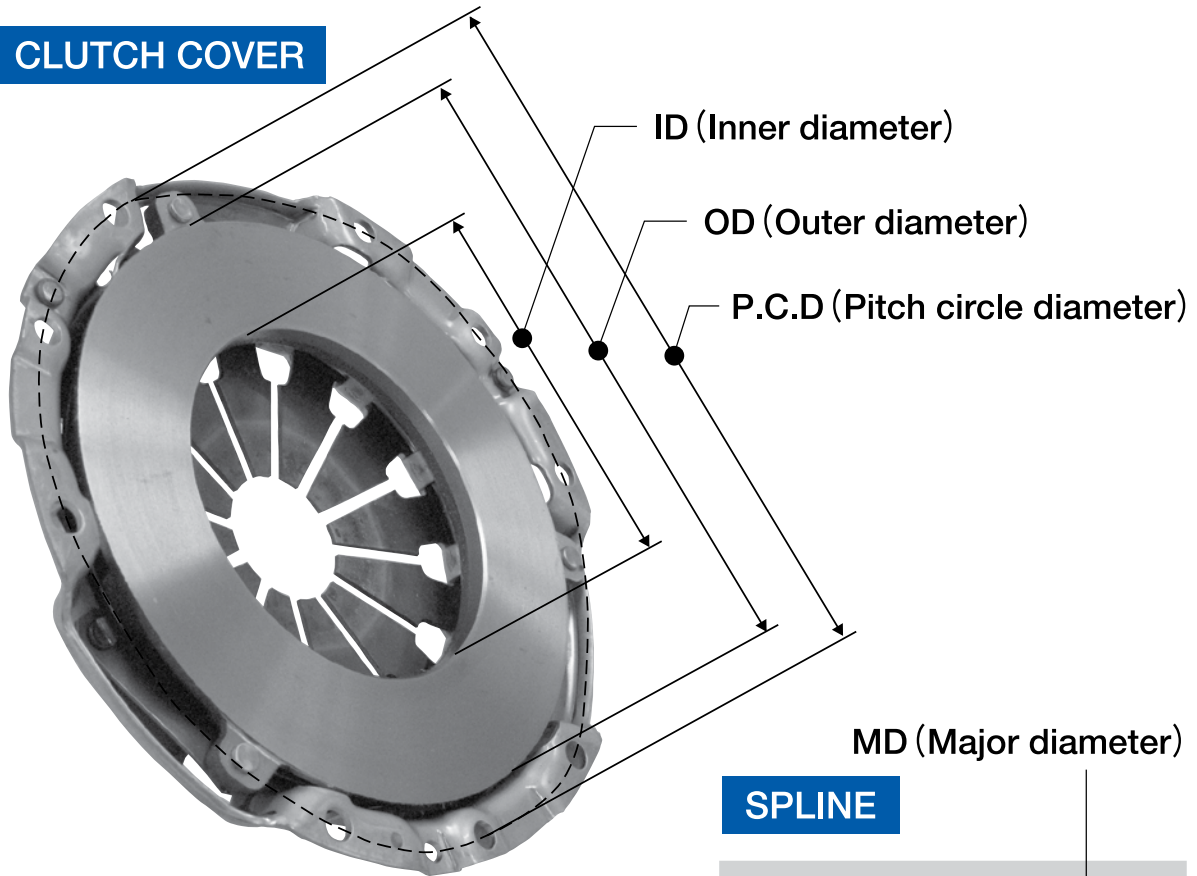

CLUTCH DISC

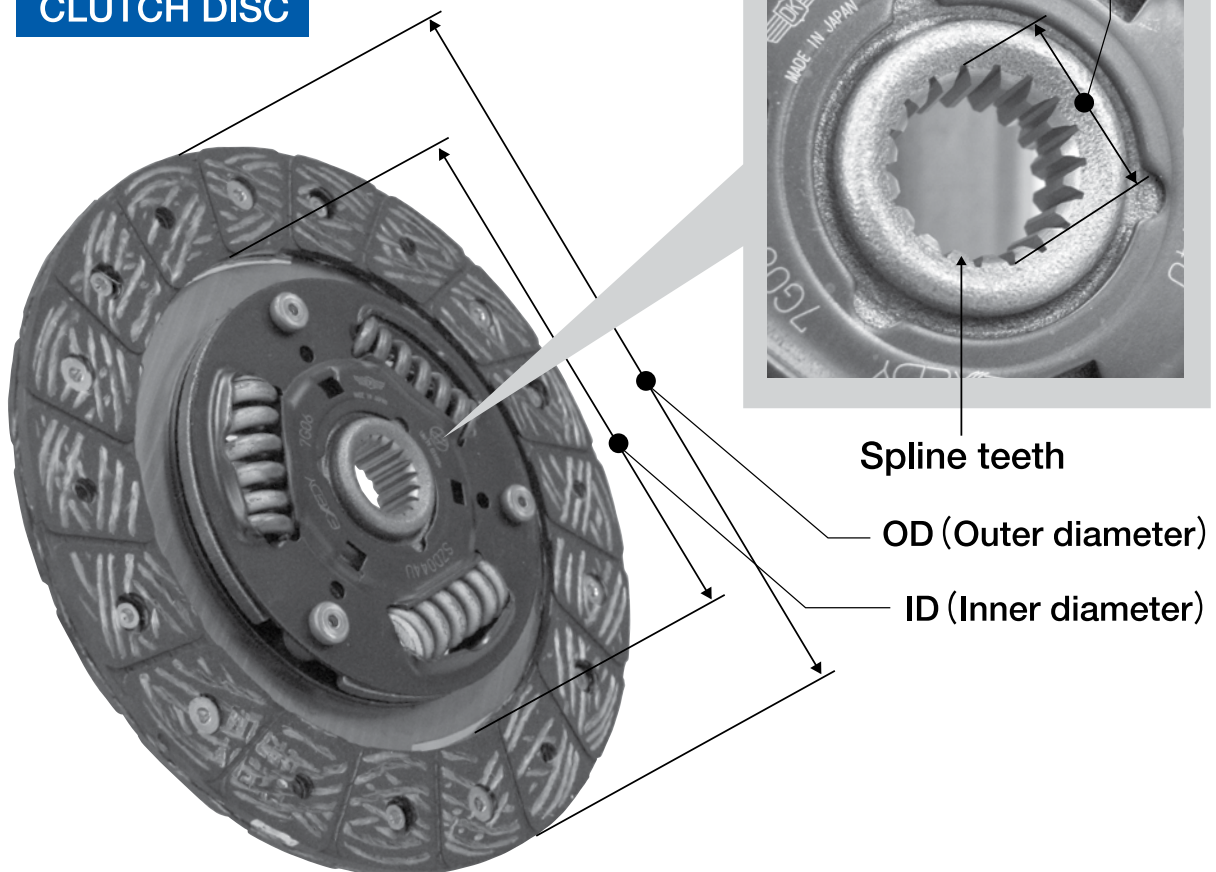

There are functionaly 8 different types in clutch cover.

1

LB LEVER BOSS TYPE



Pressure Plate and Cover are directly clawed and fixed.

DT DIAPHRAGM TAG TYPE



Diaphragm type and Pressure Plate and Cover are fixed by Strap Plate. Cover holds Diaphragm Spring.

LS LEVER STRAP TYPE



Pressure Plate and Cover are fixed by the strap plate.

PL PULL TYPE



Release Bearing is fixed on the edge of Diaphragm Spring and pull the Release Bearing.

DB DIAPHRAGM BOSS TYPE



Diaphragm type and Pressure Plate and Cover are fixed directly.

TW TWIN PLATE TYPE



Two Discs are used in one cover.

DS DIAPHRAGM STRAP TYPE

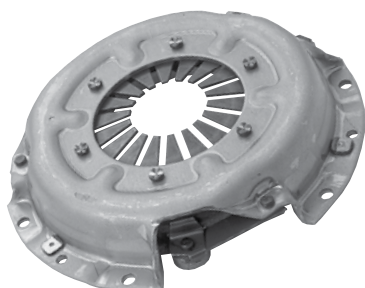

Diaphragm type and Pressure Plate and Cover are fixed by strap plate. Diaphragm and Cover are fixed by Stud Pins.

DU UNITY TYPE

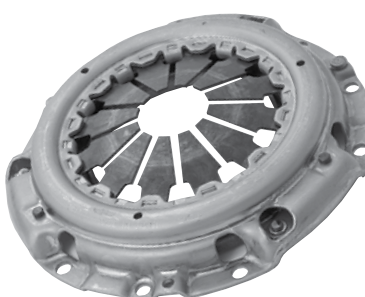

Basically the similar design as DT and, specially designed to utilize common parts.

Classification to Friction material

ORGANIC DISC



Clutch disc assembly with asbestos free organic facing

METAL DISC



Clutch disc assembly with metallic facing

COMBINATION DISC



Clutch disc assembly with combination of asbestos free organic facing and metallic facing

Classification to damper type

SOLID TYPE



Clutch disc assembly with no damper

NORMAL TYPE



Clutch disc assembly with damper

SILENT TYPE

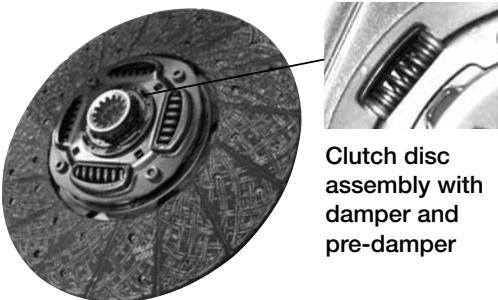

Clutch disc assembly with damper and pre-damper

WAD TYPE



Clutch disc assembly with Wide Angle Damper to absorb noise and vibration more efficiently

Various benches have been developed by EXEDY. Tests far too dangerous to be conducted in a vehicle are reproduced on these test benches with the reliability of products being evaluated.

1

Low Inertia/High Torque Dynamometer

Allows for new performance testing methods. Used for evaluations from the standpoint of the vehicle, can reproduce conditions of an actual engine.

Evaluation of damper performance for a moving vehicle. Damper evaluation includes rotational fluctuations similar to an actual car.

Cranking evaluation at engine start-up. Product noise and vibration can be evaluated during cranking.

Evaluation is possible of item such as:

- Damper Attenuation Rate
- Rattling noise when the engine is idling
- Performance when starting up from a stop
- Acceleration shock
- Engine start-up
- Low temperature Automatic Transmission Fluid tests at -30C

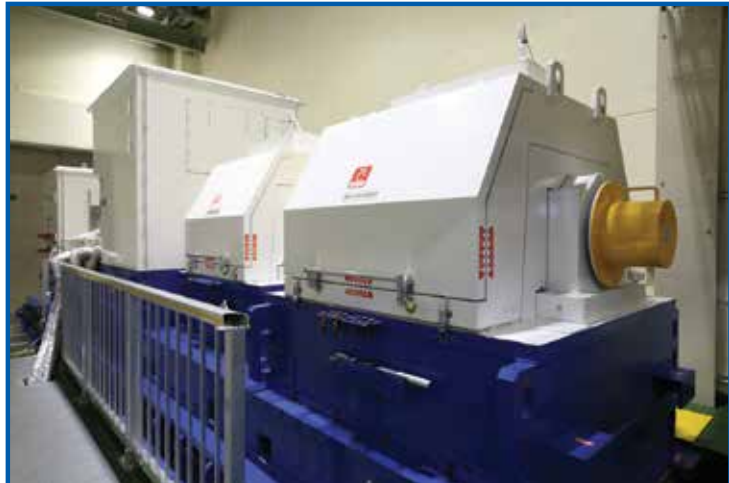

Burst Tester

Evaluation of rotational intensity at extreme high-speed tester.



Release Durability Tester

Evaluation of the intensity and fatigue of a diaphragm spring.



High Speed Full Sized Tester

Evaluation of friction characteristic and durability of clutch disc.



Torsional Durability Tester

Evaluation of the durability of clutch disc damper.



1

Customers can place PO's anytime, Check Stock & Track Orders - 24 hours, 365 days, No Human Error, No Retyping from Fax, No phone calls for inventory inquiry.

ADVANTAGES TO USING THE PORTAL...

Orders

Create New Order - Upload Excel/CSV/TSV files.

Manage Orders - View Open Orders and Completed Orders.

Inventory

Item Inquiry - Check Availability of Product.

Pricing

View Price List - Check Current Pricing.

Download Price List - Available in Excel/CSV/PDF formats.

Statement

View Statement - View Open Invoices.

Download Statement - Available in Excel/CSV/PDF formats.

Admin

User Maintenance - Setup Users, Change Passwords.

Shipping Settings - Setup Shipping Address and Ship Method.

File Upload Settings - Upload Orders from Any Spreadsheet Program.

Help

Help & Guides - Information to Help You to use the Portal successfully.

Contact Us - Give Us Your Comments, Suggestions and Inquiries.

Points & Rewards

Get points by Web Order & Exchange your point to Rewards or Discounts.

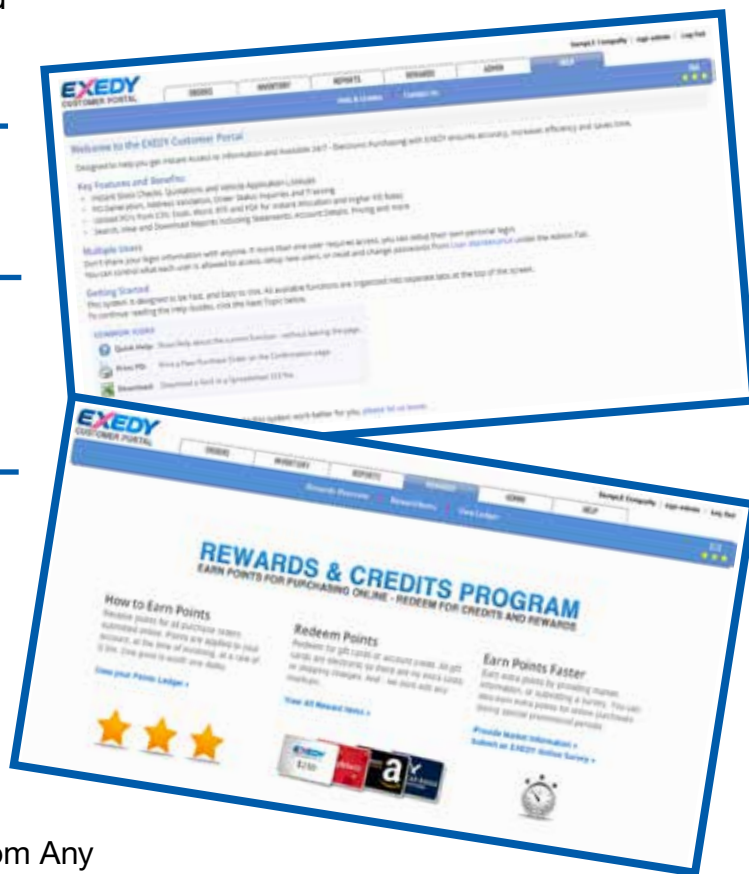

Sign-up for the portal by calling Customer Service at 1-800-346-6091 or emailing portal@exedyusa.com

EXEDY has an App on IOS!

With the App you will be able to search and browse EXEDY's massive product line-up of OEM Replacement Clutches, Performance Clutches and Transmission Parts.

This app will help you find the clutch you need for your application as well as answer some frequently asked questions.

App available through your app store.



1

LEGEND													
MT OEM Product	1	2	3	4	5	6	7	8	9	10	11	12	Note
	Maker	Type	EXD/EGP Number Rule										
Cover (EGP#)	F	M	C (Cover)	9	0	0							
Disc (EGP#)	F	M	D (Disc)	8	0	0							
Flywheel-OE (NEW)	M	B	F (Flywheel)	5	0	0							
Flywheel-Sport (EGP)	M		F (Flywheel)	5	0	1							
Flywheel-Sport (EXD)	M		F (Flywheel)	0	4								
Kit-Domestic	F	J	K (Kit)	1	0	0	0						
Kit-Domestic-Variou Suffix								F	W				Flywheel included
Kit-Domestic-Variou Suffix								H	D				Heavy Duty
Kit-Domestic-Variou Suffix								F	W	H	D		Heavy Duty with Flywheel
Kit-Domestic-Variou Suffix								A					Flywheel included
Kit-Domestic-Variou Suffix								C	S	C			Concentric Slave Cylinder
Bearing	B	R	G	0	1	9	0						
CSC Bearing (New)	C	S	C	0	1	4	3						
Pilot Bearing	P	B	G	0	0	2							
Pilot Bushing	P	B		0	0	3							
Pilot Tool	P	T		0	0	5							
Master Cylinder	M	C		1	0	1							
Slave Cylinder	S	C		1	1	7							
Bolt	B	L	T	1	0	0							

Legend for OE Kits					
First Alapha Characters - EGP number range 1000-1999 for kit					
AUK - Audi	KIK - Kia	VWK - Volkswagen	16 - Toyota	KHC - Acura/Honda	KMZ - Mazda
BMK - BMW	MBK - Mitsubishi	01 - Jeep	17 - Volkswagen	KHN - Hino	KNS - Nissan
BZK - Mercedes	MFK - Mitsubishi Fuso	02 - Audi	22 - Volvo	KHY - Hyundai	KPO - Porsche
CRK - Chrysler	MZK - Mazda	03 - BMW	23 - Daihatsu	KIS - Isuzu	KPT - Puegeot
DWK - Daewoo	NDK - Nissan Diesel UD	04 - General Motors	KAR - Alfa Romeo	KJP - Jeep	KSA - SAAB
FJK - Subaru	NSK - Nissan	05 - Dodge/Mitsubishi	KBM - BMW	KKI - KIA	KSB - Subaru
FMK - Ford	POK - Porsche	06 - Nissan	KCH - Chrysler	KLN - Lincoln	KSN - Saturn
GMK - General Motors	SBK - Saab	07 - Ford	KDG - Dodge	KMB - Mitsubishi	KSZ - Suzuki
HCK - Acura/Honda	SMK - Smart Car	08 - Acura/Honda	KFI - Fiat	KME - Mercedes	KTY - Toyota
HYK - Hyundai	SZK - Suzuki	09 - Isuzu	KFM - Ford	KMF - Mitsu Fuso	KVO - Volvo
ISK - Isuzu	TYK - Toyota	10 - Mazda	KGM - GM	KMG - Midget	KVW - VW
JDK - John Deere	VLK - Volvo	15 - Subaru			

Legend for OEM Flywheel			
CRF - Chrysler/Dodge	FF - Subaru	FWFMM - Ford	FWHDCXFF - Honda Flex Flywheel
FMF - Ford	NF - Nissan	FWFTF - Ford	FWHY - Hyundai
GMF - General Motors	TY - Toyota	FWME - Ford	FWNS - Nissan
HF - Acura/Honda	FWBM - BMW	FWFME - Ford	FWNV - Navistar
FM - Ford	FWCHR - Chrysler	FWGM - GM	FWSBL - Subaru
GF - GM	FWFM - Ford	FWGMC - GM	FWTY - Toyota
ZF - Mazda	FWFMC - Ford	FWHDA - Acura/Honda	FWVW - VW
MB - Mitsubishi	FWFMF - Ford	FWHDC - Acura/Honda	

Meaning of Kit Suffixs
HD - Heavy Duty
FW - Flywheel included
FWHD - Heavy Duty with Flywheel
LB - Less Bearing
CSC - Includes Concentric Slave Cylinder
HP - High Performance



SECTION 2
VEHICLE
APPLICATIONS
GUIDE

Liter	CC/IN	Cyl	Years		Application Information	Kit
			To	From		
ACURA (Performance Applications Available)						
<i>CL</i>						
2.2	2156	L4	1997	1997	—	08014
2.3	2254	L4	1998	1999	—	08014
3.2	3210	V6	2003	2003	Sold as kit only	HCK1007
<i>INTEGRA</i>						
1.6	1590	L4	1986	1989	—	08006
1.7	1678	L4	1992	1993	GSR	08028
1.8	1834	L4	1990	1991	—	08017
1.8	1834	L4	1992	1993	—	08028
1.8	1797	L4	1994	1999	—	KHC05
1.8	1797	L4	1997	1998	Type R	KHC13
1.8	1797	L4	2000	2001	Type R	KHC12
1.8	1834	L4	2000	2001	—	KHC12
<i>RSX</i>						
2.0	1998	L4	2002	2006	5 Spd, Sold As Kit Only	KHC09
2.0	1998	L4	2002	2006	6 Spd, Type S, Sold As Kit Only	KHC10
<i>TL</i>						
3.2	3210	V6	2004	2006	Sold as kit only	HCK1007
3.5	—	V6	2011	2014	Sold as kit only, FWD	HCK1012
3.7	3664	V 6	2010	2014	Sold as kit only, AWD, 6 Spd	HCK1012
<i>TSX</i>						
2.4	2354	L4	2003	2008	Includes Flywheel, Sold As Kit Only	HCK1001
2.4	2354	L4	2009	on	Sold As Kit Only	HCK1009
ALFA ROMEO						
<i>164</i>						
3.0	2959	V6	1991	1995	L & LS Series, Sold As Kit Only	KAR03
3.0	2959	V6	1994	1995	Q Series, Sold As Kit Only	KAR04
<i>BERLINA, GT VELOCE, SPRINT</i>						
1.8	1779	L4	1969	1971	Sold As Kit Only	KAR01
2.0	1961	L4	1970	1974	Sold As Kit Only	KAR01
<i>SPIDER</i>						
2.0	1961	L4	1970	1994	Sold As Kit Only	KAR01
AMERICAN MOTORS						
<i>AMBASSADOR</i>						
4.7	287	V8	1966	1967	—	01026
4.8	293	V8	1968	1968	—	01026
5.4	330	V8	1960	1966	4 Spd	01026
5.6	342	V8	1967	1968	4 Spd	01026
6.4	391	V8	1968	1970	4 Spd	01026
<i>AMERICAN</i>						
4.8	293	V8	1967	1968	4 Spd	01026
<i>AMX</i>						
4.8	293	V8	1968	1969	—	01026
5.6	342	V8	1968	1969	—	01026
5.9	360	V8	1970	1970	4 Spd, 4 BBL	01026
6.4	391	V8	1969	1970	4 Spd, 4 BBL	01026
<i>CLASSIC</i>						
4.7	287	V8	1964	1965	—	01026
5.4	330	V8	1966	1966	—	01026
<i>EAGLE, KAMMBACK, SX4</i>						
4.2	256	L6	1981	1988	From VIN #011C04	01007
<i>HORNET</i>						
5.9	360	V8	1971	1972	4 Spd	01026

2

EXEDY OEM	Disc (mm)	Disc (in)	Spline Dia	Splines	Master Cylinder	Slave Cylinder	Clutch Cable	Clutch Fork	New Flywheel
Y	225	8-7/8	1-1/16	24	MC234	SC642	—	—	—
Y	225	8-7/8	1-1/16	24	MC234	SC642	—	—	—
—	238	9-3/8	1	24	—	—	—	—	—
Y	200	7-7/8	7/8	21	—	—	—	—	—
Y	219	8-5/8	1-1/16	24	—	—	—	—	HCF500
Y	219	8-5/8	1	24	—	—	CC660	—	HCF500
Y	219	8-5/8	1-1/16	24	—	—	CC660	—	HCF500
Y	219	8-5/8	1-1/16	24	MC238	SC646	—	—	HCF500
Y	210	8-1/4	1-1/16	24	MC238	SC646	—	—	HCF500
Y	219	8-5/8	1-1/16	24	MC238	SC646	—	—	HCF500
Y	219	8-5/8	1-1/16	24	MC238	SC646	—	—	HCF500
Y	215	8-1/2	1-1/6	24	MC502	SC895	—	—	HCF514
Y	215	8-1/2	1-1/32	24	MC502	SC899	—	—	HCF512
—	238	9-3/8	1	24	MC502	—	—	—	—
Y	240	9-1/2	1-1/6	24	—	—	—	—	—
Y	240	9-1/2	1-1/6	24	—	—	—	—	—
—	225	8-7/8	1-1/32	24	MC502	SC895	—	—	FWHDA02
Y	225	8-7/8	1	24	MC502	SC895	—	—	HCF001/HCF513
—	228	9	15/16	20	—	—	—	—	—
—	228	9	15/16	20	—	—	—	—	—
—	215	8-1/2	1	10	—	—	—	—	—
—	215	8-1/2	1	10	—	—	—	—	—
—	215	8-1/2	1	10	—	—	—	—	—
—	265	10-1/2	1-1/8	10	—	—	—	—	—
—	265	10-1/2	1-1/8	10	—	—	—	—	—
—	265	10-1/2	1-1/8	10	—	—	—	—	—
—	265	10-1/2	1-1/8	10	—	—	—	—	—
—	265	10-1/2	1-1/8	10	—	—	—	—	—
—	265	10-1/2	1-1/8	10	—	—	—	—	—
—	265	10-1/2	1-1/8	10	—	—	—	—	—
—	265	10-1/2	1-1/8	10	—	—	—	—	—
—	265	10-1/2	1-1/8	10	—	—	—	—	—
—	265	10-1/2	1-1/8	10	—	—	—	—	—
—	265	10-1/2	1-1/8	10	—	—	—	—	—
—	265	10-1/2	1-1/8	10	—	—	—	—	—
—	265	10-1/2	1-1/8	10	—	—	—	—	—
—	265	10-1/2	1-1/8	10	—	—	—	—	—
—	265	10-1/2	1-1/8	10	—	—	—	—	—
—	265	10-1/2	1-1/8	10	—	SC832	—	—	—
—	265	10-1/2	1-1/8	10	—	—	—	—	—

2

Liter	CC/IN	Cyl	Years		Application Information	Kit
			To	From		
AMERICAN MOTORS continued						
JAVELIN						
5.6	342	V8	1968	1969	4 Spd	01026
5.9	360	V8	1970	1970	4 Spd, 4 BBL	01026
6.4	391	V8	1968	1970	4 Spd, 4 BBL	01026
MARLIN						
4.7	287	V8	1965	1966	—	01026
4.8	293	V8	1967	1967	4 Spd	01026
5.4	330	V8	1965	1966	—	01026
5.6	342	V8	1967	1967	4 Spd	01026
REBEL						
4.8	293	V8	1968	1969	3 Spd	01026
5.6	342	V8	1968	1969	4 Spd	01026
6.4	391	V8	1969	1970	4 Spd, 4 BBL	01026
AUDI						
100, 100 QUATTRO						
1.8	1760	L4	1970	1971	—	17030
1.9	1872	L4	1972	1974	—	17030
1.9	1871	L4	1975	1977	—	17030
2.3	2309	L5	1989	1989	—	02020
2.3	2309	L5	1989	1991	—	02020
200, 200 QUATTRO						
2.2	2226	L5	1989	1991	Turbo	02021
4000, 4000S, 4000 QUATTRO						
1.6	1588	L4	1982	1983	Diesel (Non-Turbo)	17002
1.8	1780	L4	1984	1987	—	17031
2.2	2144	L5	1980	1983	WE eng.	17030
2.2	2144	L5	1984	1987	—	02011
4000, 4000S, 4000 QUATTRO (CANADA)						
1.8	1780	L4	1987	1987	—	17031
2.2	2144	L5	1984	1986	—	02011
5000, 5000 QUATTRO						
2.0	1986	L5	1979	1981	Diesel	02019
2.0	1986	L5	1982	1985	Turbo, Diesel	02011
2.2	2144	L5	1978	1984	Non-Turbo	02011
2.2	2144	L5	1980	1982	Turbo	02011
2.2	2144	L5	1983	1985	Turbo	02018
2.2	2226	L5	1985	1987	Non-Turbo	02011
2.2	2226	L5	1986	1988	Turbo	02018
2.3	2309	L5	1987	1988	—	02011
80, 80 QUATTRO, 90, 90 QUATTRO						
2.0	1983	L4	1988	1990	—	02022
2.3	2309	L5	1988	1992	SOHC	02020
2.3	2309	L5	1990	1991	DOHC, 20 Valve	02023
A3						
2.0	1984	L4	2006	2007	Turbo, Includes Slave Cylinder, Sold as Kit Only	VWK1005
A4, A4 QUATTRO						
1.8	1781	L4	1997	2001	Turbo	VWK1001
1.8	1781	L4	2002	2005	Turbo, Sold as Kit Only	VWK1001
2.8	2771	V6	1996	1996	—	AUK1001
2.8	2771	V6	1997	1997	—	AUK1001
2.8	2771	V6	1998	2001	—	AUK1001
3.0	2976	V6	2002	2004	6 Spd., Sold as Kit Only	AUK1003
3.2	3123	V6	2007	2007	Sold as Kit Only	AUK1006
A6, A6 QUATTRO						
2.7	2671	V6	2000	2004	Turbo	AUK1002
2.8	2771	V6	1995	1997	—	02026

2

EXEDY OEM	Disc (mm)	Disc (in)	Spline Dia	Splines	Master Cylinder	Slave Cylinder	Clutch Cable	Clutch Fork	New Flywheel
—	265	10-1/2	1-1/8	10	—	—	—	—	—
—	265	10-1/2	1-1/8	10	—	—	—	—	—
—	265	10-1/2	1-1/8	10	—	—	—	—	—
—	265	10-1/2	1-1/8	10	—	—	—	—	—
—	265	10-1/2	1-1/8	10	—	—	—	—	—
—	265	10-1/2	1-1/8	10	—	—	—	—	—
—	265	10-1/2	1-1/8	10	—	—	—	—	—
—	265	10-1/2	1-1/8	10	—	—	—	—	—
—	265	10-1/2	1-1/8	10	—	—	—	—	—
—	265	10-1/2	1-1/8	10	—	—	—	—	—
—	265	10-1/2	1-1/8	10	—	—	—	—	—
—	265	10-1/2	1-1/8	10	—	—	—	—	—
—	215	8-1/2	13/16	24	—	—	—	—	—
—	215	8-1/2	13/16	24	—	—	—	—	—
—	215	8-1/2	13/16	24	—	—	—	—	—
—	228	9	15/16	23	—	—	—	—	—
—	228	9	15/16	23	MC102	—	—	—	—
—	240	9-1/2	13/16	24	MC102	—	—	—	—
—	190	7-1/2	1	24	MC101	SC509	—	—	—
—	210	8-1/4	13/16	24	MC101	SC509	—	—	—
—	215	8-1/2	13/16	24	MC101	SC509	—	—	—
—	228	9	13/16	24	MC101	SC509	—	—	—
—	210	8-1/4	13/16	24	MC101	SC509	—	—	—
—	228	9	13/16	24	MC101	SC509	—	—	—
—	215	8-1/2	13/16	24	MC102	SC509	—	—	—
—	228	9	13/16	24	MC102	SC509	—	—	—
—	228	9	13/16	24	MC102	SC509	—	—	—
—	228	9	13/16	24	MC102	SC509	—	—	—
—	240	9-1/2	13/16	24	MC102	SC509	—	—	—
—	228	9	13/16	24	MC102	SC509	—	—	—
—	240	9-1/2	13/16	24	MC102	SC509	—	—	—
—	228	9	13/16	24	MC101	—	—	—	—
—	228	9	15/16	23	—	—	—	—	—
—	228	9	15/16	23	—	—	—	—	—
—	240	9-1/2	15/16	23	—	—	—	—	—
—	240	9-7/16	15/16	23	—	—	—	—	—
—	228	9	15/16	23	MC108	—	—	—	FWDM02 (1997-99)
—	228	9	15/16	23	—	—	—	—	FWDM01 (2000-05)
—	240	9-7/16	15/16	23	—	—	—	—	—
—	240	9-7/16	15/16	23	MC108	—	—	—	—
—	240	9-7/16	15/16	23	—	—	—	—	—
—	240	9-7/16	15/16	23	—	—	—	—	—
—	240	9-7/16	15/16	23	—	—	—	—	—
—	240	9-7/16	15/16	23	—	—	—	—	—
—	240	9-7/16	15/16	23	—	—	—	—	—
—	240	9-1/2	15/16	23	MC108	—	—	—	—

2

Liter	CC/IN	Cyl	Years		Application Information	Kit
			To	From		
AUDI continued						
ALLROAD QUATTRO						
2.7	2671	V6	2001	2005	Turbo, Sold as Kit Only	AUK1002
COUPE GT, QUATTRO						
2.2	2144	L5	1981	1984	—	17030
2.2	2144	L5	1983	1985	Turbo	02018
2.2	2226	L5	1984	1985	—	02011
2.2	2226	L5	1986	1986	—	02011
2.2	2226	L5	1987	1987	—	02011
2.3	2309	L5	1987	1987	—	02011
2.3	2309	L5	1990	1991	20 Valve Engine	02023
FOX						
1.5	1471	L4	1973	1974	—	17002
S4						
2.2	2226	L5	1993	1994	Turbo, 20V, From CH #4AP080001	02026
2.7	2671	V6	2000	2002	Turbo	AUK1002
4.2	4163	V8	2004	2004	Sold as Kit Only (up to VIN # 8E-4-270 000)	AUK1005
4.2	4163	V8	2004	2005	Sold as Kit Only, (VIN # 8E-4-270 001 to #8E-5-084 000)	AUK1005
4.2	4163	V8	2005	2009	Sold as Kit Only, (VIN # 8E-5-084 001)	AUK1004
S6						
2.2	2226	L5	1995	1997	Turbo, 20 Valve Turbo, Sold As Kit Only	AUK1000
TT, TT QUATTRO						
1.8	1781	L4	2001	2001	Turbo, 5 Spd, From CH #8N1006001, Includes DMF, Sold As Kit Only	VWK1000
1.8	1781	L4	2001	2001	6spd, Slave Cylinder Included, Sold as kit only	VWK1002
1.8	1781	L4	2002	2003	Turbo, Sold as kit only, Includes Slave Cylinder, AWP Eng., TT Quattro	VWK1002
1.8	1781	L4	2002	2003	Turbo, Includes Dual Mass FW	VWK1000
1.8	1781	L4	2004	2004	Turbo, Sold as kit only, Includes Slave Cylinder, TT Quattro	VWK1002
1.8	1781	L4	2005	2005	Turbo, Sold as kit only, Includes Slave Cylinder	VWK1002
BMW						
2000, 2000C, CS, TI, TII. 2002TI, TII						
2.0	1990	L4	1966	1974	Sold As Kit Only	KBM05
2.0	1990	L4	1971	1976	Sold As Kit Only	KBM03
2.0	1990	L4	1973	1974	Turbo, Sold As Kit Only	KBM05
2500, 2800, 2800CS, 3.0, BAVARIA						
2.8	2788	L6	1974	1974	2800, Sold As Kit Only	03015
3.0	2985	L6	1971	1971	3.0CSL	03015
3.0	2985	L6	1971	1971	3.0SI	03015
3.0	2985	L6	1971	1972	3.0CS	03015
3.0	2985	L6	1971	1972	3.0CSI	03015
3.0	2985	L6	1971	1972	3.0S	03015
3.0	2985	L6	1973	1974	3.0CS	03015
3.0	2985	L6	1973	1974	3.0CSI	03015
3.0	2985	L6	1973	1974	3.0S	03015
3.0	2985	L6	1975	1976	3.0SI	03015
318I, IC, IS, TI						
1.8	1796	L4	1991	1995	With Air Conditioning & DMF	03028
1.9	1895	L4	1996	1996	With Air Conditioning	03028
1.9	1895	L4	1997	1997	With Air Conditioning, To 3/97	03028
1.9	1895	L4	1997	1997	With Air Conditioning, From 4/87	03028
1.9	1895	L4	1998	1999	With Air Conditioning	03028
323CI, I, IC						
2.5	2494	L6	1998	1999	—	03011
2.5	2494	L6	2000	2000	—	BMK1004
2.5	2494	L6	1998	1999	—	03011

EXEDY OEM	Disc (mm)	Disc (in)	Spline Dia	Splines	Master Cylinder	Slave Cylinder	Clutch Cable	Clutch Fork	New Flywheel
—	240	9-7/16	15/16	23	—	—	—	—	—
—	215	8-1/2	13/16	24	—	—	—	—	—
—	240	9-1/2	13/16	24	MC101	—	—	—	—
—	228	9	13/16	24	—	—	—	—	—
—	228	9	13/16	24	MC101	SC509	—	—	—
—	228	9	13/16	24	—	—	—	—	—
—	228	9	13/16	24	MC101	—	—	—	—
—	240	9-1/2	15/16	23	—	—	—	—	—
—	190	7-1/2	1	24	—	—	—	—	—
—	240	9-1/2	15/16	23	MC102	—	—	—	—
—	240	9-7/16	15/16	23	—	—	—	—	—
—	240	9-7/16	15/16	23	—	—	—	—	—
—	240	9-7/16	15/16	23	—	—	—	—	—
—	240	9-7/16	15/16	23	—	—	—	—	—
—	240	9-1/2	15/16	23	MC102	—	—	—	—
—	225	8-7/8	7/8	28	MC110	—	—	—	—
—	240	9-7/16	15/16	23	MC110	—	—	—	—
—	240	9-7/16	15/16	23	MC110	—	—	—	—
—	225	8-7/8	7/8	28	MC110	—	—	—	—
—	240	9-7/16	15/16	23	MC110	—	—	—	—
—	240	9-7/16	15/16	23	MC110	—	—	—	—
—	228	9	1-1/8	10	—	—	—	—	—
—	215	8-1/2	1-1/8	10	—	—	—	—	—
—	228	9	1-1/8	10	—	—	—	—	—
—	240	9-1/2	1-1/8	10	—	SC516	—	—	—
—	240	9-1/2	1-1/8	10	—	—	—	—	—
—	240	9-1/2	1-1/8	10	—	—	—	—	—
—	240	9-1/2	1-1/8	10	—	—	—	—	—
—	240	9-1/2	1-1/8	10	—	—	—	—	—
—	240	9-1/2	1-1/8	10	—	—	—	—	—
—	240	9-1/2	1-1/8	10	—	SC516	—	—	—
—	240	9-1/2	1-1/8	10	—	SC516	—	—	—
—	240	9-1/2	1-1/8	10	—	SC516	—	—	—
—	240	9-1/2	1-1/8	10	—	SC516	—	—	—
—	215	8-1/2	1-1/8	10	MC116	SC518	—	—	—
—	215	8-1/2	1-1/8	10	MC116	SC518	—	—	—
—	215	8-1/2	1-1/8	10	MC116	SC518	—	—	—
—	215	8-1/2	1-1/8	10	—	SC518	—	—	—
—	215	8-1/2	1-1/8	10	—	SC518	—	—	—
—	228	9	1-1/8	10	—	SC518	—	—	—
—	228	9	1-3/16	10	—	SC894	—	—	—
—	228	9	1-1/8	10	—	SC518	—	—	—

2

Liter	CC/IN	Cyl	Years		Application Information	Kit
			To	From		
BMW continued						
<i>325, CI, E, ES, I, IC, IS, IX, XI</i>						
2.5	2494	L6	1987	1989	325IS	03023
2.5	2494	L6	1987	1990	325I	03023
2.5	2494	L6	1988	1990	325IX	03023
2.5	2494	L6	1990	1992	325IS	03011
2.5	2494	L6	1991	1991	325I	03023
2.5	2494	L6	1991	1991	325IX	03023
2.5	2494	L6	1992	1992	325I	03011
2.5	2494	L6	1992	1993	325IC	03023
2.7	2693	L6	1984	1986	—	03013
2.7	2693	L6	1987	1988	—	03011
2.5	2494	L6	2004	2004	Sold as Kit Only	BMK1012
2.5	2494	L6	2005	2005	Sold as Kit Only	BMK1012
<i>328CI, I, IC, IS</i>						
2.8	2793	L6	1996	1997	328I, IC, IS Sold As Kit Only	KBM11
2.8	2793	L6	1998	1998	328I, IC, IS Sold As Kit Only	KBM11
2.8	2793	L6	1999	2000	328I, CI, Sold As Kit Only	KBM11
<i>330I, CI, XI</i>						
3.0	2979	L6	2004	2004	Sold as Kit Only	BMK1012
3.0	2979	L6	2005	2005	Sold as Kit Only	BMK1012
3.0	2979	L6	2004	2004	Sold as Kit Only	BMK1012
3.0	2979	L6	2005	2005	Sold as Kit Only	BMK1012
3.0	2996	L6	2006	2006	—	BMK1012
3.0	2979	L6	2001	2003	Sold as Kit Only	BMK1007
<i>525I</i>						
2.5	2494	L6	1989	1990	—	03023
2.5	2494	L6	1991	1995	Twin Cam with DMF	03011
<i>528, E, I</i>						
2.7	2693	L6	1982	1985	528E, Pre-Damped	03013
2.7	2693	L6	1986	1986	528E, From 5/1/86	03011
2.7	2693	L6	1986	1986	528E, Pre-Damped, To 4/30/86	03013
2.7	2693	L6	1987	1988	528E	03011
2.8	2788	L6	1979	1981	528I	03015
2.8	2793	L6	1997	1998	528I, Sold As Kit Only	KBM11
2.8	2793	L6	1999	2000	From 10/98, Sold as Kit Only	BMK1005
<i>530I</i>						
3.0	2985	L6	1975	1978	—	03015
3.0	2997	V8	1994	1995	Sold As Kit Only	KBM08
3.0	2979	L6	2004	2005	Sold as Kit Only	BMK1012
3.0	2996	L6	2006	2007	—	BMK1012
<i>533I</i>						
3.2	3210	L6	1983	1983	—	03015
3.2	3210	L6	1984	1984	From 4/1/84, Sold As Kit Only	KBM01
3.2	3210	L6	1984	1984	To 3/31/84	03015
<i>535I</i>						
3.5	3430	L6	1985	1986	Sold As Kit Only	KBM01
3.5	3430	L6	1987	1987	From 12/1/87, Sold As Kit Only	KBM04
3.5	3430	L6	1987	1987	To 11/30/87, Sold As Kit Only	KBM01
3.5	3430	L6	1988	1988	Sold As Kit Only	KBM04
3.5	3430	L6	1989	1993	Sold As Kit Only	KBM04
3.5	3430	L6	1988	1988	—	KBM01
<i>540I, IT</i>						
4.4	4398	V8	1997	2003	Sold as Kit Only	BMK1002
<i>630CSI</i>						
3.0	2985	L6	1977	1977	—	03015

2

EXEDY OEM	Disc (mm)	Disc (in)	Spline Dia	Splines	Master Cylinder	Slave Cylinder	Clutch Cable	Clutch Fork	New Flywheel
—	228	9	1-9/16	10	MC113	SC517	—	—	—
—	228	9	1-9/16	10	MC113	SC517	—	—	—
—	228	9	1-9/16	10	MC113	SC517	—	—	—
—	228	9	1-1/8	10	MC116	SC518	—	—	—
—	228	9	1-9/16	10	MC116	SC518	—	—	—
—	228	9	1-9/16	10	MC116	SC517	—	—	—
—	228	9	1-1/8	10	MC116	SC518	—	—	—
—	228	9	1-9/16	10	MC116	SC518	—	—	—
—	228	9	1-1/8	10	MC113	SC517	—	—	—
—	228	9	1-1/8	10	MC113	SC517	—	—	—
—	240	9 7/16	1 1/8	22	—	SC894	—	—	—
—	240	9 7/16	1 1/8	22	—	SC516	—	—	—
—	240	9-1/2	1-1/8	10	MC116	SC518	—	—	—
—	240	9-1/2	1-1/8	10	—	SC518	—	—	—
—	240	9-1/2	1-1/8	10	—	SC894	—	—	—
—	240	9 7/16	1 1/8	22	—	SC894	—	—	—
—	240	9 7/16	1 1/8	22	—	SC516	—	—	—
—	240	9 7/16	1 1/8	22	—	SC894	—	—	—
—	240	9 7/16	1 1/8	22	—	SC516	—	—	—
—	240	9-7/16	1-1/8	22	—	SC516	—	—	—
—	240	9-7/16	1-1/8	10	—	SC894	—	—	—
—	228	9	1-9/16	10	MC115	SC516	—	—	—
—	228	9	1-1/8	10	MC115	SC516	—	—	—
—	228	9	1-1/8	10	MC113	SC517	—	—	—
—	228	9	1-1/8	10	MC113	SC517	—	—	—
—	228	9	1-1/8	10	MC113	SC517	—	—	—
—	228	9	1-1/8	10	MC113	SC517	—	—	—
—	240	9-1/2	1-1/8	10	MC114	SC517	—	—	—
—	240	9-1/2	1-1/8	10	—	SC516	—	—	—
—	240	9-7/16	1-1/8	10	—	SC516(2000)	—	—	—
—	240	9-1/2	1-1/8	10	MC114	SC517	—	—	—
—	240	9-1/2	1-1/8	10	—	SC516	—	—	—
—	240	9 7/16	1 1/8	22	—	SC516	—	—	—
—	240	9-7/16	1-1/8	22	—	SC516	—	—	—
—	240	9-1/2	1-1/8	10	—	—	—	—	—
—	240	9-1/2	1-1/8	10	—	—	—	—	—
—	240	9-1/2	1-1/8	10	—	—	—	—	—
—	240	9-1/2	1-1/8	10	—	—	—	—	—
—	240	9-1/2	1-1/8	10	—	—	—	—	—
—	240	9-1/2	1-1/8	10	MC115	SC516	—	—	—
—	240	9-1/2	1-1/8	10	—	—	—	—	—
—	240	9-7/16	1-3/8	10	—	SC516	—	—	—
—	240	9-1/2	1-1/8	10	MC114	SC517	—	—	—

2

Liter	CC/IN	Cyl	Years		Application Information	Kit
			To	From		
BMW continued						
633CSi						
3.2	3210	L6	1978	1981	—	03015
3.2	3210	L6	1982	1982	From 9/82	03015
3.2	3210	L6	1982	1982	To 8/82	03015
3.2	3210	L6	1983	1983	—	03015
3.2	3210	L6	1984	1984	From 4/1/84	KBM07
3.2	3210	L6	1984	1984	To 3/31/84	03015
635CSi						
3.5	3430	L6	1985	1987	To 6/30/87	KBM01
3.5	3430	L6	1987	1989	From 7/1/87	KBM07
733i						
3.2	3210	L6	1978	1984	To 3/31/84	03015
3.2	3210	L6	1984	1984	From 4/1/84	KBM01
735i						
3.5	3430	L6	1985	1986	—	KBM01
3.5	3430	L6	1987	1987	—	KBM01
3.5	3430	L6	1988	1992	Sold As Kit Only	KBM07
M3						
3.0	2990	L6	1995	1995	Sold As Kit Only	KBM06
3.2	3152	L6	1996	1997	5 Spd, Sold as Kit Only	BMK1003
3.2	3152	L6	1998	1999	5 Spd, Sold as Kit Only	BMK1003
3.2	3246	L6	2001	2006	6 Spd From 3/01, Sold as Kit Only	BMK1010
M5						
3.5	3453	L6	1988	1988	Sold As Kit Only	KBM07
3.6	3553	L6	1991	1993	Sold As Kit Only	KBM07
5.0	4941	V8	2000	2003	Sold as Kit Only	BMK1006
M6						
3.5	3453	L6	1987	1988	Sold As Kit Only	KBM07
X3						
2.5	2494	L6	2004	2005	Sold as Kit Only	BMK1012
3.0	2979	L6	2004	2005	Sold as Kit Only	BMK1012
X5						
3.0	2979	L6	2001	2003	Sold as Kit Only	BMK1011
Z3						
1.9	1895	L4	1996	1997	To 2/97	03028
1.9	1895	L4	1997	1998	From 3/97	03028
2.8	2793	L6	1997	1997	To 2/97	KBM11
2.8	2793	L6	1997	1998	From 3/97, Sold As Kit Only	KBM11
2.8	2793	L6	1999	2000	From 10/98, Sold as Kit Only	BMK1005
3.2	3152	L6	1998	2002	5 Spd, Sold as Kit Only	BMK1003
Z4						
2.5	2494	L6	2003	2005	Sold as Kit Only	BMK1015
3.0	2979	L6	2003	2005	Sold as Kit Only	BMK1015
3.0	2996	L6	2006	2007	To Mar 31/2007, Sold as Kit Only	BMK1012
3.0	2996	L6	2007	2007	Sold as Kit Only	BMK1018
Z8						
5.0	4941	V8	2000	2000	Sold as Kit Only	BMK1006
5.0	4941	V8	2001	2003	Sold as Kit Only	BMK1006

BUICK

<i>CENTURION, CENTURY, ELECTRA, GRAN SPORT, LASABRE, REGAL, SKYLARK, SPECIAL, WILDCAT</i>						
2.5	153	L4	1980	1984	X Body	04077
2.5	153	L4	1985	1985	X Body	04077
2.5	153	L4	1985	1986	N Body	04005
2.5	153	L4	1987	1988	N Body	04005
2.5	153	L4	1989	1989	N Body	04005

EXEDY OEM	Disc (mm)	Disc (in)	Spline Dia	Splines	Master Cylinder	Slave Cylinder	Clutch Cable	Clutch Fork	New Flywheel
—	240	9-1/2	1-1/8	10	MC114	SC517	—	—	—
—	240	9-1/2	1-1/8	10	MC113	SC517	—	—	—
—	240	9-1/2	1-1/8	10	MC114	SC517	—	—	—
—	240	9-1/2	1-1/8	10	MC113	SC517	—	—	—
—	240	9-1/2	1-1/8	10	MC113	SC517	—	—	—
—	240	9-1/2	1-1/8	10	MC113	SC517	—	—	—
—	240	9-1/2	1-1/8	10	MC113	SC517	—	—	—
—	240	9-1/2	1-1/8	10	MC113	SC517	—	—	—
—	240	9-1/2	1-1/8	10	—	—	—	—	—
—	240	9-1/2	1-1/8	10	MC114	SC516	—	—	—
—	240	9-1/2	1-1/8	10	MC114	SC516	—	—	—
—	240	9-1/2	1-1/8	10	MC115	SC516	—	—	—
—	240	9-1/2	1-1/8	10	MC115	SC516	—	—	—
—	240	9-1/2	1-1/8	10	MC116	SC516	—	—	—
—	240	9-1/2	1-1/8	10	MC116	SC516	—	—	—
—	240	9-1/2	1-1/8	10	—	SC516	—	—	—
—	240	9-7/16	1-3/8	10	—	SC894	—	—	—
—	240	9-1/2	1-1/8	10	MC113	SC517	—	—	—
—	240	9-1/2	1-1/8	10	—	—	—	—	—
—	240	9-7/16	1-3/8	10	—	—	—	—	—
—	240	9-1/2	1-1/8	10	MC113	SC517	—	—	—
—	240	9 7/16	1 1/8	22	—	SC894	—	—	—
—	240	9 7/16	1 1/8	22	—	SC894	—	—	—
—	240	9-7/16	1-1/8	10	—	SC516	—	—	—
—	215	8-1/2	1-1/8	10	—	SC518	—	—	—
—	215	8-1/2	1-1/8	10	—	SC518	—	—	—
—	240	9-1/2	1-1/8	10	MC116	SC518	—	—	—
—	240	9-1/2	1-1/8	10	—	SC518	—	—	—
—	240	9-7/16	1-1/8	10	—	SC516	—	—	—
—	240	9-1/2	1-1/8	10	—	SC516	—	—	—
—	240	9-7/16	1-1/8	22	—	SC894	—	—	—
—	240	9-7/16	1-1/8	22	—	SC894	—	—	—
—	240	9-7/16	1-1/8	22	—	SC894	—	—	—
—	240	9 7/16	1 1/8	22	—	SC894	—	—	—
—	240	9-7/16	1-3/8	10	—	—	—	—	—
—	240	9-7/16	1-3/8	10	—	SC516	—	—	—
—	225	8-7/8	15/16	14	—	—	—	—	—
—	225	8-7/8	15/16	14	—	SC714	—	—	—
Y	215	8-1/2	1	14	—	SC714	—	—	—
Y	215	8-1/2	1	14	MC317	SC714	—	—	—
Y	215	8-1/2	1	14	—	—	—	—	—

2

Liter	CC/IN	Cyl	Years		Application Information	Kit
			To	From		

BUICK continued

CENTURION, CENTURY, ELECTRA, GRAN SPORT, LASABRE, REGAL, SKYLARK, SPECIAL, WILDCAT

2.8	171	V6	1980	1985	X Body	04077
2.8	171	V6	1984	1985	—	04077
2.8	171	V6	1988	1988	—	04088
3.0	183	V6	1987	1988	—	04005
3.2	195	V6	1979	1979	—	04021
3.8	232	V6	1977	1977	3 Spd, 10-3/8" Disc	04021
3.8	232	V6	1978	1979	4 Spd, 10-3/8" Disc	04021
3.8	232	V6	1978	1979	Turbo, 4 Spd, 10-3/8" Disc	04021
3.8	232	V6	1980	1980	Turbo, 3 Spd, 10-3/8" Disc	04021
3.8	232	V6	1980	1981	3 Spd, 10-3/8" Disc	04021
5.6	342	V8	1966	1967	10-3/8" Disc	04021
5.6	342	V8	1966	1967	11" Disc	04049
5.7	348	V8	1968	1973	3 Spd, 10-3/8" Disc	04021
5.7	348	V8	1970	1973	3 Spd, 11" Disc	04049
6.6	403	V8	1966	1966	—	04049
6.6	403	V8	1967	1969	—	04049
7.5	458	V8	1970	1970	—	04049
7.5	458	V8	1970	1973	2 BBL	04049
7.5	458	V8	1970	1973	4 Spd, 4 BBL	04020

SKYHAWK

1.8	110	L4	1983	1983	3 Speed and 5 Speed	04094
1.8	110	L4	1983	1984	4 Spd, Non-Turbo	04094
1.8	110	L4	1983	1984	5 Spd, Non-Turbo	04046
1.8	110	L4	1984	1984	4 Spd	04094
1.8	110	L4	1984	1984	5 Spd	04046
1.8	110	L4	1986	1986	4 Spd, Non-Turbo	04094
1.8	110	L4	1986	1986	5 Spd, Non-Turbo	04046
2.0	122	L4	1983	1984	5 Spd	04005
2.0	122	L4	1985	1986	5 Spd	04005
2.0	122	L4	1987	1987	4 Spd	04077
2.0	122	L4	1987	1987	4 Spd, Turbo	04077

SOMERSET

2.5	153	L4	1985	1986	—	04005
2.5	153	L4	1987	1987	—	04005
3.0	183	V6	1987	1987	—	04005

CADILLAC

CIMARRON

2.0	122	L4	1983	1986	—	04005
2.8	171	V6	1985	1986	—	04077
2.8	171	V6	1987	1988	—	04088

CTS

3.2	195	V6	2003	2004	Sold as Kit Only, Includes CSC Hydraulic Slave	GMK1022
5.7	348	V8	2005	2005	Sold as Kit Only	GMK1023
6.0	366	V8	2006	2007	Sold as Kit Only	GMK1023

CHECKER

MARATHON

3.8	232	L6	1968	1968	11" Disc	04072
4.1	250	L6	1969	1974	11" Disc	04072
5.4	330	V8	1968	1969	11" Disc	04072
5.7	348	V8	1969	1974	—	04064

EXEDY OEM	Disc (mm)	Disc (in)	Spline Dia	Splines	Master Cylinder	Slave Cylinder	Clutch Cable	Clutch Fork	New Flywheel
—	225	8-7/8	15/16	14	—	—	—	—	FWGM111
—	225	8-7/8	15/16	14	—	—	—	—	FWGM111
Y	225	8-7/8	15/16	14	—	—	—	—	FWGM111
Y	215	8-1/2	1	14	MC317	SC714	—	—	—
—	265	10-1/2	1-1/8	10	—	—	—	—	—
—	265	10-1/2	1-1/8	10	—	—	—	—	—
—	265	10-1/2	1-1/8	10	—	—	—	—	—
—	265	10-1/2	1-1/8	10	—	—	—	—	—
—	265	10-1/2	1-1/8	10	—	—	—	—	—
—	265	10-1/2	1-1/8	10	—	—	—	—	—
—	265	10-1/2	1-1/8	10	—	—	—	—	—
—	280	11	1-1/8	10	—	—	—	—	—
—	265	10-1/2	1-1/8	10	—	—	—	—	—
—	280	11	1-1/8	10	—	—	—	—	—
—	280	11	1-1/8	10	—	—	—	—	—
—	280	11	1-1/8	10	—	—	—	—	—
—	280	11	1-1/8	10	—	—	—	—	—
—	280	11	1-1/8	10	—	—	—	—	—
—	280	11	1-1/8	10	—	—	—	—	—
—	280	11	1-1/8	26	—	—	—	—	—
—	215	8-1/2	1	14	—	—	—	—	—
—	215	8-1/2	1	14	—	—	—	—	—
—	215	8-1/2	1	14	MC318	SC714	—	—	—
—	215	8-1/2	1	14	—	—	—	—	—
—	215	8-1/2	1	14	MC318	SC714	—	—	—
—	215	8-1/2	1	14	—	SC714	—	—	—
—	215	8-1/2	1	14	MC318	SC714	—	—	—
Y	215	8-1/2	1	14	—	—	—	—	—
Y	215	8-1/2	1	14	—	SC714	—	—	—
—	225	8-7/8	15/16	14	MC318	SC714	—	—	—
—	225	8-7/8	15/16	14	MC318	SC714	—	—	—
Y	215	8-1/2	1	14	MC326	SC714	—	—	—
Y	215	8-1/2	1	14	MC317	SC714	—	—	—
Y	215	8-1/2	1	14	MC317	SC714	—	—	—
Y	215	8-1/2	1	14	—	—	—	—	—
—	225	8-7/8	15/16	14	MC318	SC714	—	—	—
Y	225	8-7/8	15/16	14	MC316	SC714	—	—	—
—	240	9-7/16	1	14	—	—	—	—	—
—	290	11-7/16	1-1/8	26	—	—	—	—	—
—	290	11-7/16	1-1/8	26	—	—	—	—	—
—	280	11	1-1/8	10	—	—	—	—	—
—	280	11	1-1/8	10	—	—	—	—	—
—	280	11	1-1/8	10	—	—	—	—	—
—	300	11-3/4	1-1/8	10	—	—	—	—	—

2

Liter	CC/IN	Cyl	Years		Application Information	Kit
			To	From		
CHEVROLET (Performance Applications Available)						
<i>AVEO</i>						
1.6	98	L4	2004	2006	Sold as kit only	GMK1014
1.6	98	L4	2007	2007	Sold as kit only	GMK1014
1.6	98	L4	2008	2011	Sold as kit only	GMK1014
<i>BEL AIR, BISLAYNE, CAPRICE, IMPALA</i>						
3.8	232	L6	1963	1965	11" Disc	04072
3.9	238	L6	1955	1959	10-3/8" Diaph Clutch	04021
3.9	238	L6	1955	1959	11" Disc	04072
3.9	238	L6	1961	1962	10-3/8" Diaph Clutch	04021
3.9	238	L6	1961	1962	11" Disc	04072
4.1	250	L6	1965	1971	11" Disc	04072
4.1	250	L6	1972	1973	11" Disc	04049
4.3	262	V8	1956	1957	10-3/8" Disc	04021
4.3	262	V8	1956	1957	11" Disc	04072
4.4	269	V8	1981	1981	10-3/8" Disc	04021
4.4	269	V8	1981	1981	11" Disc	04072
4.6	281	V8	1957	1966	10-3/8" Disc	04021
4.6	281	V8	1957	1967	11" Disc	04072
4.6	281	V8	1967	1967	10-3/8" Disc	04021
5.4	330	V8	1962	1966	10-3/8" Disc	04021
5.4	330	V8	1962	1969	11" Disc	04049
5.4	330	V8	1967	1969	10-3/8" Disc	04021
5.7	348	V8	1958	1961	12" Diaph Clutch	04064
5.7	348	V8	1969	1970	12" Diaph Clutch	04064
5.7	348	V8	1969	1971	10-3/8" Disc	04021
5.7	348	V8	1969	1971	11", 10 Spline Disc	04049
5.7	348	V8	1971	1971	11", 26 Spline Disc	04020
5.7	348	V8	1972	1972	—	04049
6.5	397	V8	1966	1969	—	04049
6.7	409	V8	1962	1965	—	04021
7.0	427	V8	1966	1969	—	04049
<i>BERETTA, CORSICA</i>						
2.0	122	L4	1987	1987	—	04005
2.0	122	L4	1988	1988	Master Cyl with 4.85" Rod	04005
2.0	122	L4	1988	1988	Master Cyl with 5.00" Rod	04005
2.0	122	L4	1989	1989	—	04005
2.2	134	L4	1990	1992	—	04005
2.2	134	L4	1992	1993	—	04005
2.2	134	L4	1994	1994	—	04005
2.2	134	L4	1995	1996	Includes Slave Cylinder	04161
2.3	140	L4	1990	1992	Quad 4	04088
2.3	140	L4	1993	1994	Quad 4, Includes Slave Cylinder	04136
2.8	171	V6	1987	1987	—	04088
2.8	171	V6	1988	1988	Master Cyl with 4.85" Rod	04088
2.8	171	V6	1988	1988	Master Cyl with 5.00" Rod	04088
2.8	171	V6	1989	1989	—	04088
2.8	171	V6	1989	1989	—	04088
3.1	189	V6	1990	1992	—	04088
3.1	189	V6	1993	1993	Includes Slave Cylinder	04132
3.1	189	V6	1994	1994	Includes Slave Cylinder	04132
<i>CAMARO, Z28</i>						
2.5	153	L4	1982	1983	4 Spd	04052
2.5	153	L4	1983	1986	5 Spd, Non Pre-Damped	04053
2.5	153	L4	1983	1986	5 Spd, Pre-Damped	04129
2.5	153	L4	1984	1984	4 Spd	04052
2.8	171	V6	1985	1986	Non Pre-Damped	04053
2.8	171	V6	1985	1986	Pre-Damped	04129
2.8	171	V6	1987	1988	Non Pre-Damped	04053

2

EXEDY OEM	Disc (mm)	Disc (in)	Spline Dia	Splines	Master Cylinder	Slave Cylinder	Clutch Cable	Clutch Fork	New Flywheel
—	215	8-7/16	13/16	24	MC508	SC910	—	—	—
—	215	8-7/16	13/16	24	—	SC910	—	—	—
—	215	8-7/16	13/16	24	—	—	—	—	—
—	280	11	1-1/8	10	—	—	—	—	—
—	265	10-1/2	1-1/8	10	—	—	—	—	—
—	280	11	1-1/8	10	—	—	—	—	—
—	265	10-1/2	1-1/8	10	—	—	—	—	—
—	280	11	1-1/8	10	—	—	—	—	—
—	280	11	1-1/8	10	—	—	—	—	—
—	280	11	1-1/8	10	—	—	—	—	—
—	265	10-1/2	1-1/8	10	—	—	—	—	—
—	280	11	1-1/8	10	—	—	—	—	—
—	265	10-1/2	1-1/8	10	—	—	—	—	—
—	280	11	1-1/8	10	—	—	—	—	—
—	265	10-1/2	1-1/8	10	—	—	—	—	FWGM101
—	265	10-1/2	1-1/8	10	—	—	—	—	—
—	280	11	1-1/8	10	—	—	—	—	—
—	265	10-1/2	1-1/8	10	—	—	—	—	FWGM101
—	300	11-3/4	1-1/8	10	—	—	—	—	—
—	300	11-3/4	1-1/8	10	—	—	—	—	—
—	265	10-1/2	1-1/8	10	—	—	—	—	FWGM101
—	280	11	1-1/8	10	—	—	—	—	—
—	280	11	1-1/8	26	—	—	—	—	—
—	280	11	1-1/8	10	—	—	—	—	—
—	280	11	1-1/8	10	—	—	—	—	—
—	265	10-1/2	1-1/8	10	—	—	—	—	—
—	280	11	1-1/8	10	—	—	—	—	—
Y	215	8-1/2	1	14	MC323	SC714	—	—	FWGM10
Y	215	8-1/2	1	14	—	SC714	—	—	FWGM10
Y	215	8-1/2	1	14	MC323	SC714	—	—	FWGM10
Y	215	8-1/2	1	14	MC321	SC714	—	—	FWGM10
Y	215	8-1/2	1	14	MC321	SC714	—	—	FWGM10
Y	215	8-1/2	1	14	MC321	SC715	—	—	FWGM10
Y	215	8-1/2	1	14	MC332	SC715	—	—	FWGM10
Y	215	8-1/2	1	14	MC333	—	—	—	FWGM10
Y	225	8-7/8	15/16	14	MC321	SC715	—	—	—
Y	225	8-7/8	15/16	14	MC330	SC715	—	—	—
Y	225	8-7/8	15/16	14	MC323	SC714	—	CF134	FWGM111
Y	225	8-7/8	15/16	14	—	SC714	—	CF134	FWGM111
Y	225	8-7/8	15/16	14	—	SC714	—	CF134	FWGM111
Y	225	8-7/8	15/16	14	MC321	SC715	—	CF134	—
Y	225	8-7/8	15/16	14	MC321	SC715	—	CF134	FWGM111
—	225	8-7/8	15/16	14	MC330	—	—	—	—
—	225	8-7/8	15/16	14	MC330	—	—	—	—
—	232	9-1/8	1-1/8	10	—	—	—	—	—
—	225	8-7/8	15/16	14	MC315	SC787	—	—	—
—	232	9-1/8	1	14	MC315	SC787	—	—	—
—	232	9-1/8	1-1/8	10	MC315	SC787	—	—	—
—	225	8-7/8	15/16	14	MC320	SC787	—	—	FWGM111
—	232	9-1/8	1	14	MC320	SC787	—	—	FWGM111
—	225	8-7/8	15/16	14	MC320	SC787	—	CF129	FWGM111

Liter	CC/IN	Cyl	Years		Application Information	Kit
			To	From		
CHEVROLET (Performance Applications Available) continued						
<i>CAMARO, Z28 continued</i>						
2.8	171	V6	1987	1988	Pre-Damped	04129
2.8	171	V6	1989	1989	Non Pre-Damped	04053
2.8	171	V6	1989	1989	Pre-Damped	04129
3.1	189	V6	1990	1990	Non Pre-Damped	04053
3.1	189	V6	1990	1992	Pre-Damped	04129
3.1	189	V6	1991	1992	Non Pre-Damped	04053
3.4	207	V6	1993	1995	With Master Cyl Pushrod CV601A	04133
3.4	207	V6	1993	1995	With Master Cyl Pushrod H603A	04133
3.8	232	V6	1980	1981	—	04021
3.8	232	V6	1980	1981	—	04021
3.8	232	V6	1996	2002	—	04082
4.1	250	L6	1979	1979	—	04021
5.0	305	V8	1967	1968	—	04021
5.0	305	V8	1979	1981	10 Spine Disc	04021
5.0	305	V8	1982	1983	—	04019
5.0	305	V8	1984	1985	—	04019
5.0	305	V8	1986	1992	Light Weight Nodular Flywheel with 1-PC Crank Seal, Engine Code #F	04019
5.0	305	V8	1986	1992	Light Weight Nodular Flywheel with 1-Piece Crank Seal, Engine Code #E	04019
5.0	305	V8	1986	1992	Light Weight Nodular Flywheel with 2-PC Crank Seal	04019
5.4	330	V8	1967	1969	—	04021
5.7	348	V8	1967	1970	11", 10 Spline Disc	04049
5.7	348	V8	1969	1974	10 Spline, Saginaw Trans	04021
5.7	348	V8	1971	1974	26 Spline, Muncie Trans	04020
5.7	348	V8	1975	1975	10 Spline	04021
5.7	348	V8	1975	1975	26 Spline	04020
5.7	348	V8	1976	1979	10 Spline	04021
5.7	348	V8	1976	1979	26 Spline	04020
5.7	348	V8	1980	1981	26 Spline	04020
5.7	348	V8	1987	1992	Light Weight Nodular Flywheel with 1-PC Crank Seal, Engine Code #F	04019
5.7	348	V8	1987	1992	Light Weight Nodular Flywheel with 1-Piece Crank Seal, Engine Code #E	04019
5.7	348	V8	1987	1992	Light Weight Nodular Flywheel with 2-PC Crank Seal	04019
5.7	348	V8	1998	2002	LS1, Modular Clutch Includes Flywheel	04173
6.2	378	V8	2010	2015	Sold as Kit Only, Includes CSC Hydraulic Slave Cylinder	GMK1036
6.5	397	V8	1967	1970	—	04049
6.6	403	V8	1970	1972	4Spd, 4 BBL	04020
<i>CAVALIER, Z24</i>						
2.0	122	L4	1983	1984	5 Spd	04005
2.0	122	L4	1985	1986	4 Spd	04077
2.0	122	L4	1985	1986	5 Spd	04005
2.0	122	L4	1987	1987	4 Spd	04077
2.0	122	L4	1988	1989	4 Spd	04077
2.2	134	L4	1990	1991	—	04005
2.2	134	L4	1992	1994	—	04005
2.2	134	L4	1995	1996	Includes Slave Cylinder	04161
2.2	134	L4	1997	1999	Includes Slave Cylinder	04161
2.2	134	L4	2000	2002	SOHC, Includes Slave Cylinder, Sold As Kit Only	KGM08
2.2	134	L4	2002	2005	DOHC, Includes Slave Cylinder, Sold As Kit Only	GMK1000
2.3	140	L4	1995	1995	Includes Slave Cylinder	04158
2.4	146	L4	1996	1999	Includes Slave Cylinder	04158
2.4	146	L4	2000	2002	Includes Slave Cylinder, Sold As Kit Only	KGM04
2.8	171	V6	1985	1986	—	04077
2.8	171	V6	1987	1988	—	04088
2.8	171	V6	1989	1989	—	04088
3.1	189	V6	1990	1992	—	04088
3.1	189	V6	1993	1994	Includes Slave Cylinder	04132

EXEDY OEM	Disc (mm)	Disc (in)	Spline Dia	Splines	Master Cylinder	Slave Cylinder	Clutch Cable	Clutch Fork	New Flywheel
—	232	9-1/8	1	14	MC320	SC787	—	CF129	FWGM111
—	225	8-7/8	15/16	14	MC320	SC787	—	CF129	—
—	232	9-1/8	1	14	MC320	SC787	—	CF129	—
—	225	8-7/8	15/16	14	MC331	SC719	—	CF129	—
—	232	9-1/8	1	14	MC331	SC719	—	CF129	—
—	225	8-7/8	15/16	14	MC320	SC719	—	CF129	—
—	246	9-5/8	1-1/8	26	MC331	SC719	—	—	—
—	246	9-5/8	1-1/8	26	MC334	SC719	—	—	—
—	265	10-1/2	1-1/8	10	—	—	—	—	—
—	265	10-1/2	1-1/8	10	—	—	—	CF100	—
Y	246	9-5/8	1-1/8	26	MC334	SC746	—	—	—
—	265	10-1/2	1-1/8	10	—	—	—	CF100	FWGM101
—	265	10-1/2	1-1/8	10	—	—	—	—	—
—	265	10-1/2	1-1/8	10	—	—	—	CF100	FWGM101
—	263	10-3/8	1-1/8	26	—	—	—	—	FWGM101
—	263	10-3/8	1-1/8	26	MC315	SC787	—	CF133	FWGM101
—	263	10-3/8	1-1/8	26	MC315	SC787	—	CF133	FWGM13
—	263	10-3/8	1-1/8	26	MC315	SC787	—	CF133	FWGM12
—	263	10-3/8	1-1/8	26	MC315	SC787	—	CF133	FWGM14
—	265	10-1/2	1-1/8	10	—	—	—	—	FWGM101
—	280	11	1-1/8	10	—	—	—	—	—
—	265	10-1/2	1-1/8	10	—	—	—	—	FWGM101
—	280	11	1-1/8	26	—	—	—	—	—
—	265	10-1/2	1-1/8	10	—	—	—	—	FWGM101
—	280	11	1-1/8	26	—	—	—	—	—
—	265	10-1/2	1-1/8	10	—	—	—	CF100	FWGM101
—	280	11	1-1/8	26	—	—	—	CF100	—
—	280	11	1-1/8	26	—	—	—	—	—
—	263	10-3/8	1-1/8	26	—	—	—	—	FWGM13
—	263	10-3/8	1-1/8	26	—	—	—	—	FWGM12
—	263	10-3/8	1-1/8	26	—	—	—	—	FWGM14
—	300	11-3/4	1-1/8	26	MC334	SC746	—	—	—
—	290	11-7/16	1-1/8	26	—	—	—	—	—
—	280	11	1-1/8	10	—	—	—	—	—
—	280	11	1-1/8	26	—	—	—	—	—
Y	215	8-1/2	1	14	—	—	—	CF106	FWGM10
—	225	8-7/8	15/16	14	MC318	SC714	—	CF106	—
Y	215	8-1/2	1	14	MC318	SC714	—	CF106	FWGM10
—	225	8-7/8	15/16	14	MC316	SC714	—	CF106	—
—	225	8-7/8	15/16	14	—	SC714	—	CF106	—
Y	215	8-1/2	1	14	MC327	SC714	—	—	—
Y	215	8-1/2	1	14	MC327	SC715	—	—	—
Y	215	8-1/2	1	14	MC333	—	—	—	FWGM10
Y	215	8-1/2	1	14	MC333	—	—	—	—
Y	215	8-1/2	1	14	—	—	—	—	—
Y	225	8-7/8	1	14	—	—	—	—	—
Y	225	8-7/8	15/16	14	MC333	—	—	—	—
Y	225	8-7/8	15/16	14	MC333	—	—	—	—
Y	225	8-7/8	1	14	—	—	—	—	—
—	225	8-7/8	15/16	14	MC318	SC714	—	—	FWGM111
Y	225	8-7/8	15/16	14	MC316	SC714	—	—	FWGM111
Y	225	8-7/8	15/16	14	MC316	SC714	—	—	—
Y	225	8-7/8	15/16	14	MC327	SC715	—	—	—
—	225	8-7/8	15/16	14	MC330	—	—	—	—

2

Liter	CC/IN	Cyl	Years		Application Information	Kit
			To	From		
CHEVROLET (Performance Applications Available) continued						
<i>CELEBRITY</i>						
2.5	153	L4	1984	1986	—	04077
2.8	171	V6	1984	1985	—	04077
2.8	171	V6	1986	1986	—	04077
2.8	171	V6	1987	1988	—	04088
<i>CHEVELLE, MALIBU, EL CAMINO, MONTE CARLO</i>						
3.3	201	V6	1979	1979	—	04021
3.8	232	V6	1980	1981	—	04021
4.4	269	V8	1979	1981	—	04021
4.6	281	V8	1964	1966	4 Spd	04021
4.6	281	V8	1964	1967	4 Spd	04021
5.0	305	V8	1968	1973	4 Spd	04021
5.0	305	V8	1979	1981	—	04021
5.0	305	V8	1979	1981	Monte Carlo	04021
5.4	330	V8	1964	1968	Raised Diaph	04021
5.7	348	V8	1969	1970	11"Disc	04049
5.7	348	V8	1969	1975	Raised Diaph	04021
5.7	348	V8	1971	1972	11", 26 Spline Disc	04020
5.7	348	V8	1973	1977	Raised Diaph	04021
5.7	348	V8	1978	1978	—	04021
6.5	397	V8	1966	1970	—	04049
6.6	403	V8	1970	1970	—	04049
6.6	403	V8	1970	1970	Monte Carlo	04049
6.6	403	V8	1971	1971	Monte Carlo	04020
6.6	403	V8	1972	1972	—	04049
7.4	452	V8	1970	1975	—	04020
<i>CHEVETTE</i>						
1.4	85	L4	1976	1977	—	04057
1.6	98	L4	1976	1981	—	04057
1.8	110	L4	1981	1986	Diesel	04058
<i>CHEVY II, NOVA</i>						
1.6	98	L4	1985	1988	FWD	16070
4.1	250	L6	1979	1979	—	04021
4.6	281	V8	1964	1966	Raised Diaph Clutch	04021
4.6	281	V8	1967	1967	Raised Diaph Clutch	04021
5.0	305	V8	1978	1979	—	04021
5.4	330	V8	1965	1966	Raised Diaph Clutch	04021
5.4	330	V8	1967	1968	Raised Diaph Clutch	04021
5.7	348	V8	1970	1975	3 Spd	04021
5.7	348	V8	1976	1977	3 Spd	04021
6.5	397	V8	1968	1968	—	04049
6.5	397	V8	1970	1970	—	04049
<i>CITATION</i>						
2.5	153	L4	1980	1982	—	04077
2.5	153	L4	1982	1985	—	04077
2.8	171	V6	1980	1981	—	04077
2.8	171	V6	1982	1984	—	04077
2.8	171	V6	1985	1985	—	04077
<i>COBALT</i>						
2.0	122	L4	2005	2007	Supercharged, Luk Original, Includes CSC Hydraulic Slave, Sold as Kit Only	GMK1016
2.2	134	L4	2005	2010	Includes Slave Cylinder, Sold As Kit Only	GMK1010
2.4	146	L4	2006	2009	Includes Slave Cylinder, Sold As Kit Only	GMK1010
<i>CORVETTE</i>						
4.6	281	V8	1957	1961	Carbureted	04084
5.4	330	V8	1962	1964	—	04084
5.4	330	V8	1965	1966	—	04021
5.4	330	V8	1967	1968	—	04021

2

EXEDY OEM	Disc (mm)	Disc (in)	Spline Dia	Splines	Master Cylinder	Slave Cylinder	Clutch Cable	Clutch Fork	New Flywheel
—	225	8-7/8	15/16	14	—	—	—	—	—
—	225	8-7/8	15/16	14	—	—	—	—	FWGM111
—	225	8-7/8	15/16	14	MC589	SC714	—	—	FWGM111
Y	225	8-7/8	15/16	14	MC319	SC714	—	CF134	FWGM111
—	265	10-1/2	1-1/8	10	—	—	—	—	—
—	265	10-1/2	1-1/8	10	—	—	—	—	—
—	265	10-1/2	1-1/8	10	—	—	—	—	—
—	265	10-1/2	1-1/8	10	—	—	—	—	—
—	265	10-1/2	1-1/8	10	—	—	—	—	FWGM101
—	265	10-1/2	1-1/8	10	—	—	—	—	FWGM101
—	265	10-1/2	1-1/8	10	—	—	—	CF100	FWGM14
—	265	10-1/2	1-1/8	10	—	—	—	CF100	FWGM101
—	265	10-1/2	1-1/8	10	—	—	—	—	FWGM101
—	280	11	1-1/8	10	—	—	—	—	—
—	265	10-1/2	1-1/8	10	—	—	—	—	FWGM101
—	280	11	1-1/8	26	—	—	—	—	—
—	265	10-1/2	1-1/8	10	—	—	—	CF100	FWGM101
—	265	10-1/2	1-1/8	10	—	—	—	CF100	FWGM101
—	280	11	1-1/8	10	—	—	—	—	—
—	280	11	1-1/8	10	—	—	—	—	—
—	280	11	1-1/8	10	—	—	—	—	—
—	280	11	1-1/8	26	—	—	—	—	—
—	280	11	1-1/8	10	—	—	—	—	—
—	280	11	1-1/8	26	—	—	—	—	—
—	184	7-1/4	1	14	—	—	—	—	—
—	184	7-1/4	1	14	—	—	—	—	—
Y	200	7-7/8	1	24	—	—	—	—	—
—	200	7-7/8	15/16	21	MC256	SC669	—	—	TYF508
—	265	10-1/2	1-1/8	10	—	—	—	CF100	FWGM101
—	265	10-1/2	1-1/8	10	—	—	—	—	—
—	265	10-1/2	1-1/8	10	—	—	—	—	FWGM101
—	265	10-1/2	1-1/8	10	—	—	—	CF100	FWGM101
—	265	10-1/2	1-1/8	10	—	—	—	—	—
—	265	10-1/2	1-1/8	10	—	—	—	—	FWGM101
—	265	10-1/2	1-1/8	10	—	—	—	—	FWGM101
—	265	10-1/2	1-1/8	10	—	—	—	CF100	FWGM101
—	280	11	1-1/8	10	—	—	—	—	—
—	280	11	1-1/8	10	—	—	—	—	—
—	225	8-7/8	15/16	14	—	—	—	—	—
—	225	8-7/8	15/16	14	—	—	—	CF106	—
—	225	8-7/8	15/16	14	—	—	—	—	FWGM111
—	225	8-7/8	15/16	14	—	—	—	CF106	FWGM111
—	225	8-7/8	15/16	14	—	—	—	—	FWGM111
—	238	9-3/8	1	14	—	—	—	—	—
Y	225	8-7/8	15/16	14	—	—	—	—	—
Y	225	8-7/8	15/16	14	—	—	—	—	—
—	254	10	1-1/8	10	—	—	—	—	—
—	254	10	1-1/8	10	—	—	—	—	—
—	265	10-1/2	1-1/8	10	—	—	—	—	—
—	265	10-1/2	1-1/8	10	—	—	—	—	FWGM101

Liter	CC/IN	Cyl	Years		Application Information	Kit
			To	From		
CHEVROLET (Performance Applications Available) continued						
<i>CORVETTE continued</i>						
5.7	348	V8	1969	1970	10-3/8" Disc	04021
5.7	348	V8	1969	1970	11" Disc	04049
5.7	348	V8	1971	1971	3 Spd	04021
5.7	348	V8	1971	1971	4 Spd	04019
5.7	348	V8	1972	1972	4 Spd, 4 BBL	04019
5.7	348	V8	1973	1977	—	04020
5.7	348	V8	1978	1978	10-3/8" Disc	04021
5.7	348	V8	1978	1978	11" Disc	04020
5.7	348	V8	1979	1981	—	04020
5.7	348	V8	1984	1984	—	04019
5.7	348	V8	1985	1987	With .38" Bushing	04080
5.7	348	V8	1985	1988	With .43" Bushing	04080
5.7	348	V8	1988	1988	—	04080
5.7	348	V8	1989	1990	L98, Cover Includes Bearing	04113
5.7	348	V8	1990	1990	LT5, Cover Includes Bearing	04114
5.7	348	V8	1991	1991	L98, Cover Includes Bearing	04113
5.7	348	V8	1991	1993	LT5, Cover Includes Bearing	04114
5.7	348	V8	1992	1993	LT1, Cover Includes Bearing	04113
5.7	348	V8	1994	1994	LT1 & LT4, Cover Includes Bearing	04142
5.7	348	V8	1994	1996	LT5, Cover Includes Bearing	04143
5.7	348	V8	1997	2004	LS1, Modular Clutch Includes Flywheel	04173
6.2	378	V8	2010	2013	Sold as Kit Only, Includes CSC Hydraulic Slave Cylinder	GMK1035
7.0	427	V8	1966	1966	10-3/8" Disc	04021
7.0	427	V8	1966	1969	10-3/8" Disc, Nodular Flywheel with 2 PC Crank Seal	04021
7.0	427	V8	1966	1969	11" Disc	04049
7.0	427	V8	1967	1969	10-3/8" Disc, Standard Flywheel	04021
7.4	452	V8	1970	1974	—	04020
<i>HHR</i>						
2.2	134	L4	2006	2011	Includes Slave Cylinder, Sold As Kit Only	GMK1010
2.4	146	L4	2006	2011	Includes Slave Cylinder, Sold As Kit Only	GMK1010
<i>METRO</i>						
1.0	61	L3	1998	2000	—	04124
1.3	79	L4	1998	2001	—	04100
<i>MONZA, VEGA</i>						
5.0	305	V8	1977	1979	—	04021
<i>PRIZM</i>						
1.8	110	L4	1998	2002	—	KTY03
<i>SPECTRUM</i>						
1.5	92	L4	1985	1988	Non-Turbo	04063
1.5	92	L4	1987	1988	Turbo	04099
<i>SPRINT</i>						
1.0	61	L3	1985	1988	Non-Turbo	04076
1.0	61	L3	1987	1988	Turbo	04139
1.0	61	L3	1989	1991	Non-Turbo CANADA	04139
1.0	61	L3	1989	1991	Turbo CANADA	04139
CHEVROLET TRUCK, SUV & VAN						
<i>ASTRO</i>						
2.5	153	L4	1985	1989	—	04053
4.3	262	V6	1985	1987	—	04086
4.3	262	V6	1988	1989	—	04086

EXEDY OEM	Disc (mm)	Disc (in)	Spline Dia	Splines	Master Cylinder	Slave Cylinder	Clutch Cable	Clutch Fork	New Flywheel
—	265	10-1/2	1-1/8	10	—	—	—	—	FWGM101
—	280	11	1-1/8	10	—	—	—	—	—
—	265	10-1/2	1-1/8	10	—	—	—	—	FWGM101
—	263	10-3/8	1-1/8	10	—	—	—	—	FWGM101
—	263	10-3/8	1-1/8	26	—	—	—	—	FWGM101
—	280	11	1-1/8	26	—	—	—	—	—
—	265	10-1/2	1-1/8	10	—	—	—	—	FWGM101
—	280	11	1-1/8	26	—	—	—	—	—
—	280	11	1-1/8	26	—	—	—	—	—
—	263	10-3/8	1-1/8	26	MC306	SC704	—	—	FWGM101
—	273	10-3/4	1-1/8	26	MC307	SC704	—	—	—
—	273	10-3/4	1-1/8	26	MC306	SC704	—	—	—
—	273	10-3/4	1-1/8	26	MC306	SC704	—	—	—
—	280	11	1-1/8	26	—	SC880	—	—	—
—	280	11	1-1/8	26	—	SC880	—	—	—
—	280	11	1-1/8	26	—	SC867	—	—	—
—	280	11	1-1/8	26	—	SC867	—	—	—
—	280	11	1-1/8	26	—	SC867	—	—	—
—	280	11	1-1/8	26	—	SC867	—	—	—
—	280	11	1-1/8	26	—	SC867	—	—	—
—	300	11-3/4	1-1/8	26	MC423	SC780	—	—	—
—	290	11-7/16	1-1/8	26	—	—	—	—	—
—	265	10-1/2	1-1/8	10	—	—	—	—	FWGM14
—	265	10-1/2	1-1/8	10	—	—	—	—	FWGM14
—	280	11	1-1/8	10	—	—	—	—	—
—	265	10-1/2	1-1/8	10	—	—	—	—	FWGM101
—	280	11	1-1/8	26	—	—	—	—	—
Y	225	8-7/8	15/16	14	—	—	—	—	—
Y	225	8-7/8	15/16	14	—	—	—	—	—
Y	170	6-11/16	3/4	18	—	—	—	—	—
Y	190	7-1/2	3/4	18	—	—	—	—	—
—	265	10-1/2	1-1/8	10	—	—	—	—	FWGM101
—	210	8-1/4	1	21	MC265	SC842	—	—	—
Y	184	7-1/4	1	14	—	—	—	—	—
Y	215	8-1/2	1	14	—	—	—	—	—
Y	160	6-5/16	3/4	18	—	—	—	—	—
Y	190	7-1/2	3/4	18	—	—	—	—	—
Y	190	7-1/2	3/4	18	—	—	—	—	—
Y	190	7-1/2	3/4	18	—	—	—	—	—
—	225	8-7/8	15/16	14	MC305	SC703	—	—	FWGM115
—	280	11	1	14	MC305	SC703	—	—	—
—	280	11	1	14	MC305	SC703	—	—	FWGM108

2

Liter	CC/IN	Cyl	Years		Application Information	Kit
			To	From		
CHEVROLET LIGHT TRUCK, SUV & VAN						
<i>BLAZER (FULL SIZE), C10-30, K10-30, R10-30, V10-30, SILVERADO, TAHOE</i>						
3.8	232	L6	1963	1967	11" Disc	04072
3.8	232	L6	1969	1969	12" Diaph Clutch	04064
3.8	232	L6	1969	1969	12" Diaph Clutch with Ceramic Button	04105
3.9	238	L6	1961	1962	12" Diaph Clutch	04064
3.9	238	L6	1961	1962	12" Diaph Clutch with Ceramic Button	04105
4.1	250	L6	1966	1976	11" Disc	04072
4.1	250	L6	1977	1984	11" Disc	04049
4.1	250	L6	1977	1984	12" Diaph Clutch	04064
4.1	250	L6	1977	1984	12" Diaph Clutch with Ceramic Button	04105
4.3	262	L6	1961	1962	11" Disc	04072
4.3	262	L6	1961	1962	12" Diaph Clutch	04064
4.3	262	L6	1961	1962	12" Diaph Clutch with Ceramic Button	04105
4.3	262	V6	1985	1987	—	04089
4.3	262	V6	1988	1991	To 1/31/91	04089
4.3	262	V6	1991	1991	From 1/31/91	04121
4.3	262	V6	1992	1994	—	04121
4.3	262	V6	1995	1995	—	04121
4.3	262	V6	1996	1998	—	KGM10
4.3	262	V6	1999	2000	Silverado	KGM17
4.3	262	V6	2001	2007	Slave Cylinder fits 5spd only	KGM21
4.6	281	V8	1961	1967	11" Disc	04072
4.6	281	V8	1961	1967	12" Diaph Clutch	04064
4.6	281	V8	1961	1967	12" Diaph Clutch with Ceramic Button	04105
4.8	293	L6	1963	1968	11" Disc	04072
4.8	293	L6	1969	1974	11" Disc	04049
4.8	293	L6	1974	1974	11" Disc, LPG Gas	04049
4.8	293	L6	1974	1974	LPG Gas, 11" Disc	04049
4.8	293	L6	1975	1984	11" Disc	04049
4.8	293	L6	1985	1985	11" Disc	04049
4.8	293	L6	1985	1986	—	04081
4.8	293	L6	1987	1988	R & V Series	04081
4.8	293	V8	1999	2000	Silverado	04181
4.8	293	V8	2001	2003	Silverado	KGM44
4.8	293	V8	2004	2004	Silverado	KGM44
4.8	293	V8	2005	2006	Sold as Kit Only	GMK1020
5.0	305	V8	1968	1973	11" Disc	04049
5.0	305	V8	1976	1984	11" Disc	04049
5.0	305	V8	1976	1984	12" Diaph Clutch	04064
5.0	305	V8	1976	1984	12" Diaph Clutch with Ceramic Button	04105
5.0	305	V8	1985	1987	—	04081
5.0	305	V8	1985	1991	—	04081
5.0	305	V8	1992	1994	—	04121
5.0	305	V8	1995	1996	—	04121
5.0	305	V8	1996	1998	—	04160
5.4	330	V8	1962	1962	12" Diaph Clutch	04064
5.4	330	V8	1962	1962	12" Diaph Clutch with Ceramic Button	04105
5.4	330	V8	1964	1968	12" Diaph Clutch	04064
5.4	330	V8	1964	1968	12" Diaph Clutch with Ceramic Button	04105
5.7	348	V8	1969	1984	11" Disc	04049
5.7	348	V8	1969	1984	12" Diaph Clutch	04064
5.7	348	V8	1969	1984	12" Diaph Clutch with Ceramic Button	04105
5.7	348	V8	1974	1974	11" Disc, LPG Gas	04049
5.7	348	V8	1974	1974	LPG Gas, 11" Disc	04049
5.7	348	V8	1974	1974	LPG Gas, 12" Diaph Clutch with Ceramic Button	04105
5.7	348	V8	1974	1974	LPG Gas, 12" Diaph Clutch, Non-Pre Damped	04064
5.7	348	V8	1978	1981	11" Disc, Diesel	04049
5.7	348	V8	1978	1981	Diesel, 12" Diaph Clutch	04064

2

EXEDY OEM	Disc (mm)	Disc (in)	Spline Dia	Splines	Master Cylinder	Slave Cylinder	Clutch Cable	Clutch Fork	New Flywheel
—	280	11	1-1/8	10	—	—	—	—	—
—	300	11-3/4	1-1/8	10	—	—	—	—	—
—	300	11-3/4	1-1/8	10	—	—	—	—	—
—	300	11-3/4	1-1/8	10	—	—	—	—	—
—	300	11-3/4	1-1/8	10	—	—	—	—	—
—	280	11	1-1/8	10	—	—	—	—	—
—	280	11	1-1/8	10	—	—	—	—	—
—	300	11-3/4	1-1/8	10	—	—	—	—	—
—	300	11-3/4	1-1/8	10	—	—	—	—	—
—	280	11	1-1/8	10	—	—	—	—	—
—	300	11-3/4	1-1/8	10	—	—	—	—	—
—	300	11-3/4	1-1/8	10	—	—	—	—	—
—	280	11	1-1/8	10	MC309	SC827	—	—	FWGM108
—	280	11	1-1/8	10	MC310	SC708	—	—	FWGM108
—	280	11	1-1/8	10	MC310	SC708	—	—	FWGM108
—	280	11	1-1/8	10	MC372	SC741	—	—	FWGM108
—	280	11	1-1/8	10	MC380	SC741	—	—	FWGM108
—	280	11	1-1/8	10	MC377	SC746	—	—	FWGM108
—	280	11	1-1/8	10	MC381	SC746	—	—	—
—	280	11	1-1/8	10	MC381	SC799	—	—	—
—	280	11	1-1/8	10	—	—	—	—	—
—	300	11-3/4	1-1/8	10	—	—	—	—	—
—	300	11-3/4	1-1/8	10	—	—	—	—	—
—	280	11	1-1/8	10	—	—	—	—	—
—	280	11	1-1/8	10	—	—	—	—	—
—	280	11	1-1/8	10	—	—	—	—	—
—	280	11	1-1/8	10	—	—	—	—	—
—	280	11	1-1/8	10	—	—	—	—	FWGM104
—	280	11	1-1/8	10	MC309	SC827	—	—	FWGM104
—	280	11	1-1/8	10	MC309	SC827	—	CF116	FWGM104
—	280	11	1-1/8	10	MC309	SC827	—	CF116	FWGM104
—	302	11-7/8	1-1/8	10	MC381	SC746	—	—	—
—	302	11-7/8	1-1/8	10	MC381	SC799	—	—	—
—	302	11-7/8	1-1/8	10	MC381	SC937	—	—	—
—	302	11-7/8	1-1/8	10	MC456	SC801	—	—	—
—	280	11	1-1/8	10	—	—	—	—	—
—	280	11	1-1/8	10	—	—	—	—	—
—	300	11-3/4	1-1/8	10	—	—	—	—	—
—	300	11-3/4	1-1/8	10	—	—	—	—	—
—	280	11	1-1/8	10	MC309	SC827	—	—	—
—	280	11	1-1/8	10	MC310	SC708	—	—	—
—	280	11	1-1/8	10	MC372	SC741	—	—	—
—	280	11	1-1/8	10	MC387	SC741	—	—	—
—	302	11-7/8	1-1/8	10	MC377	SC746	—	—	—
—	300	11-3/4	1-1/8	10	—	—	—	—	—
—	300	11-3/4	1-1/8	10	—	—	—	—	—
—	300	11-3/4	1-1/8	10	—	—	—	—	—
—	300	11-3/4	1-1/8	10	—	—	—	—	—
—	280	11	1-1/8	10	—	—	—	—	—
—	300	11-3/4	1-1/8	10	—	—	—	—	—
—	300	11-3/4	1-1/8	10	—	—	—	—	—
—	280	11	1-1/8	10	—	—	—	—	—
—	280	11	1-1/8	10	—	—	—	—	—
—	300	11-3/4	1-1/8	10	—	—	—	—	—
—	300	11-3/4	1-1/8	10	—	—	—	—	—
—	280	11	1-1/8	10	—	—	—	—	—
—	300	11-3/4	1-1/8	10	—	—	—	—	—

Liter	CC/IN	Cyl	Years		Application Information	Kit
			To	From		
CHEVROLET LIGHT TRUCK, SUV & VAN continued						
<i>BLAZER (FULL SIZE), C10-30, K10-30, R10-30, V10-30, SILVERADO, TAHOE continued</i>						
5.7	348	V8	1978	1981	Diesel, 12" Diaph Clutch with Ceramic Button	04105
5.7	348	V8	1985	1985	12" Diaph Clutch	04064
5.7	348	V8	1985	1985	12" Diaph Clutch with Ceramic Button	04105
5.7	348	V8	1985	1990	11" Disc	04049
5.7	348	V8	1986	1987	12" Diaph Clutch	04064
5.7	348	V8	1986	1987	12" Diaph Clutch with Ceramic Button	04105
5.7	348	V8	1988	1990	11" Disc	04049
5.7	348	V8	1988	1990	12" Diaph Clutch	04064
5.7	348	V8	1988	1990	12" Diaph Clutch with Ceramic Button	04105
5.7	348	V8	1988	1991	R & V Series 12" Diaph Clutch with Ceramic Button	04105
5.7	348	V8	1988	1991	R & V Series, 12" Diaph Clutch	04064
5.7	348	V8	1991	1991	11" Disc, To 1/31/91	04049
5.7	348	V8	1991	1991	11" Disc, To 1/31/91	04049
5.7	348	V8	1991	1991	12" Diaph Clutch with Ceramic Button, To 1/31/91	04105
5.7	348	V8	1991	1991	12" Diaph Clutch, To 1/31/91	04064
5.7	348	V8	1991	1991	Non Pre-Damped, From 2/1/91	04122
5.7	348	V8	1991	1991	R & V Series Pre-Damped, From 2/1/91	04128
5.7	348	V8	1992	1994	Non Pre-Damped	04122
5.7	348	V8	1992	1994	Pre-Damped	04128
5.7	348	V8	1995	1995	Non Pre-Damped	04122
5.7	348	V8	1995	1995	Pre-Damped	04128
5.7	348	V8	1996	2000	—	04170
6.0	366	V8	1999	2000	Silverado	GMK1009
6.0	366	V8	2001	2003	Silverado	GMK1009
6.0	366	V8	2003	2006	Silverado	GMK1009
6.2	378	V8	1982	1987	Diesel	04087
6.2	378	V8	1988	1989	Diesel	04087
6.2	378	V8	1990	1991	Diesel	04122
6.2	378	V8	1991	1991	R & V Series Diesel	04122
6.2	378	V8	1992	1993	Diesel	04122
6.5	397	V8	1968	1969	11" Disc	04049
6.5	397	V8	1968	1969	Gas	04049
6.5	397	V8	1992	1994	Turbo Diesel for DMF, Not included	04131
6.5	397	V8	1992	1994	Turbo Diesel with Solid Flywheel Option. Kit includes flywheel.	04163A
6.5	397	V8	1992	1994	Turbo, Diesel with Solid Flywheel Option. Kit does not include flywheel.	04163
6.5	397	V8	1995	1995	Diesel with Solid Flywheel Option. Kit does not include flywheel.	04163
6.5	397	V8	1995	1995	Diesel with Solid Flywheel Option. Kit includes flywheel.	04163A
6.5	397	V8	1995	1995	Turbo Diesel for DMF, Not included	04131
6.5	397	V8	1996	2002	Turbo Diesel 5 Spd with LUK type solid flywheel. Kit does not include flywheel.	04154
6.5	397	V8	1996	2002	Turbo Diesel 5 Spd with LUK type solid flywheel. Kit includes flywheel.	04154A
6.5	397	V8	1996	2002	Turbo Diesel 5 Spd with Valeo type DMF. Kit does not include flywheel.	KGM12
6.5	397	V8	1996	2002	Turbo Diesel 5 Spd with Valeo type DMF. Kit includes flywheel.	KGM12A
6.6	403	V8	1970	1971	12" Diaph Type Clutch with Ceramic Button	04105
6.6	403	V8	1970	1972	12" Diaph Clutch	04064
6.6	403	V8	1970	1972	12" Diaph Clutch with Ceramic Button	04105
6.6	403	V8	1978	1980	Gas	04020
6.6	403	V8	2001	2003	Diesel 6 Spd, with DMF, Kit does not include flywheel, Does not include Release Bearing	KGM13
6.6	403	V8	2001	2003	Diesel 6 Spd, with DMF, Kit includes flywheel, Does not include Release Bearing	KGM13A
6.6	403	V8	2004	2005	Diesel 6 Spd, with DMF, Kit does not include flywheel, Does not include Release Bearing	KGM13
6.6	403	V8	2004	2005	Diesel 6 Spd, with DMF, Kit includes flywheel, Does not include Release Bearing	KGM13A
6.6	403	V8	2006	2006	Turbo, Diesel, Includes CSC Hydraulic Slave Cylinder, Sold as Kit Only, Fits Dual Mass FW	GMK1029
7.4	452	V8	1973	1973	12" Diaph Clutch with Ceramic Button	04105
7.4	452	V8	1973	1973	Diaph Clutch	04122
7.4	452	V8	1974	1984	12" Diaph Type Clutch with Ceramic Button	04105
7.4	452	V8	1974	1984	Diaph Clutch	04122
7.4	452	V8	1985	1986	12" Diaph Clutch with Ceramic Button	04105
7.4	452	V8	1985	1986	Diaph Clutch	04122
7.4	452	V8	1987	1991	12" Diaph Clutch, Non-Pre Damped	04064

2

EXEDY OEM	Disc (mm)	Disc (in)	Spline Dia	Splines	Master Cylinder	Slave Cylinder	Clutch Cable	Clutch Fork	New Flywheel
—	300	11-3/4	1-1/8	10	—	—	—	—	—
—	300	11-3/4	1-1/8	10	MC309	SC827	—	—	—
—	300	11-3/4	1-1/8	10	MC309	SC827	—	—	—
—	280	11	1-1/8	10	MC309	SC827	—	—	—
—	300	11-3/4	1-1/8	10	MC309	SC827	—	—	FWGM103
—	300	11-3/4	1-1/8	10	MC309	SC827	—	—	FWGM103
—	280	11	1-1/8	10	—	SC708	—	—	—
—	300	11-3/4	1-1/8	10	MC309	SC708	—	—	FWGM103
—	300	11-3/4	1-1/8	10	MC309	SC708	—	—	FWGM103
—	300	11-3/4	1-1/8	10	MC309	SC827	—	—	FWGM103
—	300	11-3/4	1-1/8	10	MC309	SC827	—	—	FWGM103
—	280	11	1-1/8	10	—	SC708	—	—	—
—	280	11	1-1/8	10	MC309	SC827	—	—	—
—	300	11-3/4	1-1/8	10	MC310	SC708	—	—	FWGM103
—	300	11-3/4	1-1/8	10	MC310	SC708	—	—	FWGM103
—	302	11-7/8	1-1/8	10	MC309	SC827	—	—	—
—	300	11-3/4	1-1/8	10	MC309	SC827	—	—	—
—	302	11-7/8	1-1/8	10	MC372	SC741	—	—	—
—	300	11-3/4	1-1/8	10	MC372	SC741	—	—	—
—	302	11-7/8	1-1/8	10	MC380	SC741	—	—	—
—	300	11-3/4	1-1/8	10	MC380	SC741	—	—	—
—	305	12	1-1/8	10	MC377	SC746	—	—	—
—	290	11-1/2	1-1/8	10	MC381	BRG0152	—	—	—
—	290	11-1/2	1-1/8	10	MC381	BRG0152	—	—	—
—	290	11-1/2	1-1/8	10	MC381	BRG0152	—	—	—
—	302	11-7/8	1-1/8	10	MC309	SC827	—	—	—
—	302	11-7/8	1-1/8	10	MC310	SC708	—	—	—
—	302	11-7/8	1-1/8	10	MC310	SC708	—	—	—
—	302	11-7/8	1-1/8	10	MC309	SC741	—	—	—
—	302	11-7/8	1-1/8	10	MC372	SC741	—	—	—
—	280	11	1-1/8	10	—	—	—	—	—
—	280	11	1-1/8	10	—	—	—	—	—
—	300	11-3/4	1-1/8	10	MC372	SC741	—	—	—
—	302	11-7/8	1-1/8	10	MC372	SC741	—	—	FWGMC126
—	302	11-7/8	1-1/8	10	MC372	SC741	—	—	FWGMC126
—	302	11-7/8	1-1/8	10	MC380	SC741	—	—	FWGMC126
—	302	11-7/8	1-1/8	10	MC380	SC741	—	—	FWGMC126
—	300	11-3/4	1-1/8	10	MC380	SC741	—	—	—
—	302	11-7/8	1-1/8	10	MC377	SC746	—	—	FWGMC126
—	302	11-7/8	1-1/8	10	MC377	SC746	—	—	FWGMC126
—	300	11-3/4	1-1/8	10	MC377	SC746	—	—	FWGMC01
—	300	11-3/4	1-1/8	10	MC377	SC746	—	—	FWGMC01
—	300	11-3/4	1-1/8	10	—	—	—	—	—
—	300	11-3/4	1-1/8	10	—	—	—	—	—
—	280	11	1-1/8	26	—	—	—	—	FWGM100
—	305	12	1-3/8	10	MC381	BRG0152	—	—	—
—	305	12	1-3/8	10	MC381	BRG0152	—	—	DMF029
—	305	12	1-3/8	10	MC381	BRG0152	—	—	—
—	305	12	1-3/8	10	MC381	BRG0152	—	—	DMF029
—	305	12	1-3/8	10	MC381	BRG0152	—	—	—
—	300	11-3/4	1-1/8	10	—	—	—	—	—
—	302	11-7/8	1-1/8	10	—	—	—	—	—
—	300	11-3/4	1-1/8	10	—	—	—	—	FWGM102
—	302	11-7/8	1-1/8	10	—	—	—	—	FWGM102
—	300	11-3/4	1-1/8	10	MC309	SC827	—	—	FWGM102
—	302	11-7/8	1-1/8	10	MC309	SC827	—	—	FWGM102
—	300	11-3/4	1-1/8	10	MC310	SC708	—	—	FWGM102

2

Liter	CC/IN	Cyl	Years		Application Information	Kit
			To	From		
CHEVROLET LIGHT TRUCK, SUV & VAN continued						
<i>BLAZER (FULL SIZE), C10-30, K10-30, R10-30, V10-30, SILVERADO, TAHOE continued</i>						
7.4	452	V8	1987	1991	Pre-Damped	04122
7.4	452	V8	1987	1991	R & V Series Pre-Damped	04122
7.4	452	V8	1988	1988	12" Diaph Clutch, Non-Pre Damped	04064
7.4	452	V8	1988	1988	R & V Series Pre-Damped	04122
7.4	452	V8	1988	1991	R & V Series, Non Pre-Damped	04064
7.4	452	V8	1988	1995	12" Diaph Clutch, Non-Pre Damped	04064
7.4	452	V8	1988	1995	Pre-Damped	04122
7.4	452	V8	1990	1995	12" Diaph Clutch, Non-Pre Damped	04064
7.4	452	V8	1990	1995	Pre-Damped	04122
7.4	452	V8	1996	2000	—	04154
7.4	452	V8	1996	2000	Turbo Diesel 5 Spd with LUK type solid flywheel. Kit includes flywheel.	04154A
8.1	494	V8	2001	2002	5 Spd	KGM18
8.1	494	V8	2001	2003	6 Spd, Sold as Kit Only, Includes Slave Cylinder	GMK1025
8.1	494	V8	2004	2006	From Jan 1/2004, Slave Cylinder Included, Sold as Kit Only	GMK1019
COLORADO						
2.8	171	L4	2004	2004	Sold as Kit Only, Includes CSC Hydraulic Slave	GMK1015
2.8	171	L4	2005	2006	Sold as Kit Only, Includes CSC Hydraulic Slave	GMK1015
3.5	214	L5	2004	2006	Sold as Kit Only	GMK1028
G10-30 VAN						
3.2	195	L6	1964	1966	11" Disc	04072
3.8	232	L6	1966	1969	11" Disc	04072
4.1	250	L6	1967	1976	11" Disc	04072
4.1	250	L6	1977	1984	11" Disc	04049
4.1	250	L6	1977	1984	12" Diaph Clutch with Ceramic Button	04105
4.1	250	L6	1977	1984	12" Diaph Clutch, Non-Pre Damped	04064
4.3	262	V6	1985	1988	—	04089
4.3	262	V6	1988	1990	—	04089
4.3	262	V6	1988	1990	—	04089
4.8	293	L6	1971	1974	11" Disc	04049
4.8	293	L6	1971	1980	12" Diaph Clutch with Ceramic Button	04105
4.8	293	L6	1971	1980	12" Diaph Clutch, Non-Pre Damped	04064
4.8	293	L6	1974	1974	11" Disc, LPG Gas	04049
4.8	293	L6	1974	1974	LPG Gas, 12" Diaph Clutch with Ceramic Button	04105
4.8	293	L6	1974	1974	LPG Gas, 12" Diaph Clutch, Non-Pre Damped	04064
4.8	293	L6	1975	1980	11" Disc	04049
5.0	305	V8	1968	1973	11" Disc	04049
5.0	305	V8	1977	1984	11" Disc	04049
5.0	305	V8	1977	1984	12" Diaph Clutch with Ceramic Button	04105
5.0	305	V8	1977	1984	12" Diaph Clutch, Non-Pre Damped	04064
5.0	305	V8	1985	1990	—	04121
5.7	348	V8	1970	1984	11" Disc	04049
5.7	348	V8	1970	1984	12" Diaph Clutch with Ceramic Button	04105
5.7	348	V8	1970	1984	12" Diaph Clutch, Non-Pre Damped	04064
5.7	348	V8	1974	1974	11" Disc, LPG Gas	04049
5.7	348	V8	1974	1974	LPG Gas, 12" Diaph Clutch with Ceramic Button	04105
5.7	348	V8	1974	1974	LPG Gas, 12" Diaph Clutch, Non-Pre Damped	04064
5.7	348	V8	1985	1987	12" Diaph Clutch, Non-Pre Damped	04064
5.7	348	V8	1985	1987	Pre-Damped	04128
5.7	348	V8	1988	1990	12" Diaph Clutch, Non-Pre Damped	04064
5.7	348	V8	1988	1990	Pre-Damped	04128
6.2	378	V8	1983	1990	Diesel, Non Pre-Damped	04087
6.2	378	V8	1983	1990	Diesel, Pre-Damped	04128
6.6	403	V8	1978	1980	—	04020
7.4	452	V8	1973	1973	12" Diaph Clutch, Non-Pre Damped	04064
7.4	452	V8	1973	1973	Pre-Damped	04122
7.4	452	V8	1974	1976	12" Diaph Clutch, Non-Pre Damped	04064
7.4	452	V8	1974	1976	Pre-Damped	04122
7.4	452	V8	1988	1990	12" Diaph Clutch, Non-Pre Damped	04064
7.4	452	V8	1988	1990	Pre-Damped	04122

2

EXEDY OEM	Disc (mm)	Disc (in)	Spline Dia	Splines	Master Cylinder	Slave Cylinder	Clutch Cable	Clutch Fork	New Flywheel
—	302	11-7/8	1-1/8	10	MC310	SC708	—	—	FWGM102
—	302	11-7/8	1-1/8	10	MC309	SC827	—	—	FWGM102
—	300	11-3/4	1-1/8	10	MC309	SC741	—	—	FWGM102
—	302	11-7/8	1-1/8	10	MC309	SC741	—	—	FWGM102
—	300	11-3/4	1-1/8	10	MC309	SC827	—	—	FWGM102
—	300	11-3/4	1-1/8	10	MC380	SC741	—	—	FWGM102
—	302	11-7/8	1-1/8	10	MC380	SC741	—	—	FWGM102
—	300	11-3/4	1-1/8	10	MC372	SC741	—	—	FWGM102
—	302	11-7/8	1-1/8	10	MC372	SC741	—	—	FWGM102
—	302	11-7/8	1-1/8	10	MC377	SC746	—	—	—
—	302	11-7/8	1-1/8	10	MC377	SC746	—	—	FWGMC126
—	300	11-3/4	1-1/4	10	MC377	SC801	—	—	—
—	295	11-11/16	1-3/8	10	MC377	BRG0152	—	—	—
—	295	11-11/16	1-3/8	10	MC377	BRG0152	—	—	—
—	264	10-3/8	1-1/8	26	MC462	SC801	—	—	—
—	264	10-3/8	1-1/8	26	MC462	SC809	—	—	—
—	265	10-7/16	1-3/16	26	MC462	SC809	—	—	—
—	280	11	1-1/8	10	—	—	—	—	—
—	280	11	1-1/8	10	—	—	—	—	—
—	280	11	1-1/8	10	—	—	—	—	—
—	280	11	1-1/8	10	—	—	—	—	—
—	300	11-3/4	1-1/8	10	—	—	—	—	—
—	300	11-3/4	1-1/8	10	—	—	—	—	—
—	280	11	1-1/8	10	—	—	—	—	—
—	280	11	1-1/8	10	—	—	—	—	FWGM108
—	280	11	1-1/8	10	—	SC708	—	—	FWGM108
—	280	11	1-1/8	10	—	—	—	—	—
—	300	11-3/4	1-1/8	10	—	—	—	—	—
—	300	11-3/4	1-1/8	10	—	—	—	—	—
—	280	11	1-1/8	10	—	—	—	—	—
—	300	11-3/4	1-1/8	10	—	—	—	—	—
—	300	11-3/4	1-1/8	10	—	—	—	—	—
—	280	11	1-1/8	10	—	—	—	—	FWGM104
—	280	11	1-1/8	10	—	—	—	—	—
—	280	11	1-1/8	10	—	—	—	—	—
—	300	11-3/4	1-1/8	10	—	—	—	—	—
—	300	11-3/4	1-1/8	10	—	—	—	—	—
—	280	11	1-1/8	10	—	—	—	—	—
—	300	11-3/4	1-1/8	10	—	—	—	—	—
—	300	11-3/4	1-1/8	10	—	—	—	—	—
—	300	11-3/4	1-1/8	10	MC309	SC827	—	—	—
—	300	11-3/4	1-1/8	10	MC309	SC827	—	—	—
—	300	11-3/4	1-1/8	10	—	—	—	—	FWGM103
—	300	11-3/4	1-1/8	10	—	—	—	—	FWGM103
—	302	11-7/8	1-1/8	10	—	—	—	—	—
—	300	11-3/4	1-1/8	10	—	—	—	—	—
—	280	11	1-1/8	26	—	—	—	—	FWGM100
—	300	11-3/4	1-1/8	10	—	—	—	—	—
—	302	11-7/8	1-1/8	10	—	—	—	—	—
—	300	11-3/4	1-1/8	10	—	—	—	—	FWGM102
—	302	11-7/8	1-1/8	10	—	—	—	—	FWGM102
—	300	11-3/4	1-1/8	10	—	—	—	—	FWGM102
—	302	11-7/8	1-1/8	10	—	—	—	—	FWGM102

2

Liter	CC/IN	Cyl	Years		Application Information	Kit
			To	From		
CHEVROLET LIGHT TRUCK, SUV & VAN continued						
<i>LUV PICKUP</i>						
1.8	110	L4	1972	1977	—	04058
1.8	110	L4	1978	1979	—	04058
1.8	110	L4	1980	1982	2 WD	04058
1.8	110	L4	1980	1982	4 WD	04071
2.2	134	L4	1981	1982	Diesel	04071
<i>P10-30 STEPVAN</i>						
3.2	195	L6	1966	1966	11" Disc	04072
3.8	232	L6	1963	1969	11" Disc	04072
3.9	238	L6	1961	1962	12" Diaph Clutch	04064
3.9	238	L6	1961	1962	12" Diaph Type Clutch with Ceramic Button	04105
4.1	250	L6	1966	1966	11" Disc	04072
4.1	250	L6	1968	1974	11" Disc	04072
4.1	250	L6	1976	1976	11" Disc	04072
4.1	250	L6	1979	1979	11" Disc	04049
4.1	250	L6	1979	1979	12" Diaph Clutch	04064
4.1	250	L6	1979	1979	12" Diaph Clutch with Ceramic Button	04105
4.3	262	V6	1990	1991	—	04089
4.3	262	V6	1992	1995	—	04121
4.3	262	V6	1996	1996	—	KGM10
4.3	262	V6	1997	1998	—	KGM10
4.3	262	V6	1999	1999	—	KGM17
4.6	281	V8	1961	1962	11" Disc	04072
4.8	293	L6	1964	1968	11" Disc	04072
4.8	293	L6	1969	1974	11" Disc	04049
4.8	293	L6	1974	1974	11" Disc, LPG Gas	04049
4.8	293	L6	1975	1984	11" Disc	04049
4.8	293	L6	1985	1989	—	04081
5.0	305	V8	1968	1979	—	04049
5.7	348	V8	1970	1978	11" Clutch	04049
5.7	348	V8	1970	1978	12" Diaph Clutch with Ceramic Button	04105
5.7	348	V8	1970	1985	12" Diaph Clutch	04064
5.7	348	V8	1979	1985	12" Diaph Clutch with Ceramic Button	04105
5.7	348	V8	1986	1988	12" Diaph Clutch	04064
5.7	348	V8	1986	1988	12" Diaph Clutch with Ceramic Button	04105
5.7	348	V8	1989	1990	12" Diaph Clutch	04064
5.7	348	V8	1989	1990	12" Diaph Clutch with Ceramic Button	04105
5.7	348	V8	1991	1991	12" Diaph Clutch with Ceramic Button, To 1/31/91	04105
5.7	348	V8	1991	1991	12" Diaph Clutch, To 3/31/91	04064
5.7	348	V8	1992	1995	Non Pre-Damped	04122
5.7	348	V8	1992	1995	Pre-Damped	04128
5.7	348	V8	1996	1996	—	04160
5.7	348	V8	1997	1999	—	04170
6.2	378	V8	1982	1989	Diesel, Non Pre-Damped	04087
6.2	378	V8	1982	1989	Diesel, Pre-Damped	04128
6.2	378	V8	1990	1991	Diesel, Non Pre-Damped	04087
6.2	378	V8	1990	1991	Diesel, Pre-Damped	04128
6.2	378	V8	1992	1993	Diesel, Non Pre-Damped	04087
6.2	378	V8	1992	1993	Diesel, Pre-Damped	04128
6.5	397	V8	1994	1994	Diesel, Non Pre-Damped	04146
6.5	397	V8	1994	1994	Diesel, Pre-Damped	04122
6.5	397	V8	1994	1994	Turbo Diesel, Non Pre-Damped	04146
6.5	397	V8	1994	1994	Turbo Diesel, Pre-Damped	04122
6.5	397	V8	1995	1995	Diesel, Non Pre-Damped	04146
6.5	397	V8	1995	1995	Diesel, Pre-Damped	04122
6.5	397	V8	1995	1995	Turbo Diesel, Non Pre-Damped	04146
6.5	397	V8	1995	1995	Turbo Diesel, Pre-Damped	04122
6.5	397	V8	1996	1999	Turbo Diesel 5 Spd with LUK Solid type FW. Kit does not include flywheel.	04154

EXEDY OEM	Disc (mm)	Disc (in)	Spline Dia	Splines	Master Cylinder	Slave Cylinder	Clutch Cable	Clutch Fork	New Flywheel
Y	200	7-7/8	1	24	MC488	—	—	—	—
Y	200	7-7/8	1	24	—	—	—	—	—
Y	200	7-7/8	1	24	—	—	—	—	—
Y	215	8-1/2	1	24	—	—	—	—	—
Y	215	8-1/2	1	24	—	—	—	—	—
—	280	11	1-1/8	10	—	—	—	—	—
—	280	11	1-1/8	10	—	—	—	—	—
—	300	11-3/4	1-1/8	10	—	—	—	—	—
—	300	11-3/4	1-1/8	10	—	—	—	—	—
—	280	11	1-1/8	10	—	—	—	—	—
—	280	11	1-1/8	10	—	—	—	—	—
—	280	11	1-1/8	10	—	—	—	—	—
—	280	11	1-1/8	10	—	—	—	—	—
—	300	11-3/4	1-1/8	10	—	—	—	—	—
—	300	11-3/4	1-1/8	10	—	—	—	—	—
—	280	11	1-1/8	10	MC375	SC744	—	—	FWGM108
—	280	11	1-1/8	10	MC374	SC741	—	—	FWGM108
—	280	11	1-1/8	10	MC379	SC746	—	—	FWGM108
—	280	11	1-1/8	10	MC379	SC746	—	—	—
—	280	11	1-1/8	10	—	—	—	—	—
—	280	11	1-1/8	10	—	—	—	—	—
—	280	11	1-1/8	10	—	—	—	—	—
—	280	11	1-1/8	10	—	—	—	—	—
—	280	11	1-1/8	10	—	—	—	—	FWGM104
—	280	11	1-1/8	10	—	—	—	—	FWGM104
—	280	11	1-1/8	10	—	—	—	—	—
—	280	11	1-1/8	10	—	—	—	—	—
—	300	11-3/4	1-1/8	10	—	—	—	—	—
—	300	11-3/4	1-1/8	10	—	—	—	—	—
—	300	11-3/4	1-1/8	10	—	—	—	—	—
—	300	11-3/4	1-1/8	10	—	—	—	—	FWGM103
—	300	11-3/4	1-1/8	10	—	—	—	—	FWGM103
—	300	11-3/4	1-1/8	10	MC375	SC744	—	—	FWGM103
—	300	11-3/4	1-1/8	10	MC375	SC744	—	—	FWGM103
—	300	11-3/4	1-1/8	10	MC375	SC744	—	—	FWGM103
—	300	11-3/4	1-1/8	10	MC375	SC744	—	—	FWGM103
—	302	11-7/8	1-1/8	10	MC374	SC741	—	—	—
—	300	11-3/4	1-1/8	10	MC374	SC741	—	—	—
—	302	11-7/8	1-1/8	10	MC379	SC746	—	—	—
—	305	12	1-1/8	10	MC379	SC746	—	—	—
—	302	11-7/8	1-1/8	10	MC309	SC827	—	—	—
—	300	11-3/4	1-1/8	10	MC309	SC827	—	—	—
—	302	11-7/8	1-1/8	10	MC375	SC744	—	—	—
—	300	11-3/4	1-1/8	10	MC375	SC744	—	—	—
—	302	11-7/8	1-1/8	10	MC374	SC741	—	—	—
—	300	11-3/4	1-1/8	10	MC374	SC741	—	—	—
—	302	11-7/8	1-1/8	10	MC372	SC741	—	—	—
—	302	11-7/8	1-1/8	10	MC372	SC741	—	—	—
—	302	11-7/8	1-1/8	10	MC372	SC741	—	—	—
—	302	11-7/8	1-1/8	10	MC372	SC741	—	—	—
—	302	11-7/8	1-1/8	10	—	SC741	—	—	—
—	302	11-7/8	1-1/8	10	—	SC741	—	—	—
—	302	11-7/8	1-1/8	10	—	SC741	—	—	—
—	302	11-7/8	1-1/8	10	—	SC741	—	—	—
—	302	11-7/8	1-1/8	10	—	SC741	—	—	—
—	302	11-7/8	1-1/8	10	MC379	SC746	—	—	FWGMC126

2

Liter	CC/IN	Cyl	Years		Application Information	Kit
			To	From		
CHEVROLET LIGHT TRUCK, SUV & VAN continued						
<i>P10-30 STEPVAN continued</i>						
6.5	397	V8	1996	1999	Turbo Diesel 5 Spd with LUK Solid Type FW. Kit includes flywheel.	04154A
6.5	397	V8	1996	1999	Turbo Diesel 5 Spd with Valeo type DMF. Kit does not include flywheel.	KGM12
6.5	397	V8	1996	1999	Turbo Diesel 5 Spd with Valeo type DMF. Kit includes flywheel.	KGM12A
6.6	403	V8	1972	1977	12" Diaph Clutch, Non-Pre Damped	04064
6.7	409	V8	1962	1962	12" Diaph Clutch, Non-Pre Damped	04064
6.7	409	V8	1964	1965	12" Diaph Clutch, Non-Pre Damped	04064
7.4	452	V8	1970	1971	12" Diaph Clutch, Non-Pre Damped	04064
7.4	452	V8	1970	1971	Pre-Damped	04122
7.4	452	V8	1973	1973	12" Diaph Clutch, Non-Pre Damped	04064
7.4	452	V8	1973	1973	Pre-Damped	04122
7.4	452	V8	1974	1986	12" Diaph Clutch, Non-Pre Damped	04064
7.4	452	V8	1974	1986	Pre-Damped	04122
7.4	452	V8	1987	1987	12" Diaph Clutch, Non-Pre Damped	04064
7.4	452	V8	1987	1987	Pre-Damped	04122
7.4	452	V8	1988	1991	12" Diaph Clutch, Non-Pre Damped	04064
7.4	452	V8	1988	1991	Pre-Damped	04122
7.4	452	V8	1992	1994	12" Diaph Clutch, Non-Pre Damped	04064
7.4	452	V8	1992	1994	Pre-Damped	04122
7.4	452	V8	1995	1995	12" Diaph Clutch, Non-Pre Damped	04064
7.4	452	V8	1995	1995	Pre-Damped	04122
7.4	452	V8	1996	1999	—	04154
7.4	452	V8	1996	1999	Turbo Diesel 5 Spd with LUK Solid Type FW. Kit includes flywheel.	04154A
<i>S10/T10, BLAZER</i>						
2.0	122	L4	1983	1983	Non Pre-Damped	04065
2.0	122	L4	1983	1983	Pre-Damped	04130
2.0	122	L4	1984	1984	Non Pre-Damped	04065
2.0	122	L4	1984	1984	Pre-Damped	04130
2.2	134	L4	1994	1995	Non Pre-Damped	04138
2.2	134	L4	1996	2001	Non Pre-Damped	04155
2.5	153	L4	1985	1989	Non Pre-Damped	04065
2.5	153	L4	1985	1989	Pre-Damped	04130
2.5	153	L4	1990	1991	Non Pre-Damped	04065
2.5	153	L4	1990	1991	Pre-Damped	04130
2.5	153	L4	1992	1993	Non Pre-Damped	04065
2.5	153	L4	1992	1993	Pre-Damped	04130
2.8	171	V6	1985	1989	Non Pre-Damped	04065
2.8	171	V6	1985	1989	Pre-Damped	04130
2.8	171	V6	1990	1991	Non Pre-Damped	04065
2.8	171	V6	1990	1991	Pre-Damped	04130
2.8	171	V6	1992	1993	Non Pre-Damped	04065
2.8	171	V6	1992	1993	Pre-Damped	04130
4.3	262	V6	1988	1989	—	04089
4.3	262	V6	1990	1991	—	04089
4.3	262	V6	1992	1993	—	04089
4.3	262	V6	1994	1995	—	04168
4.3	262	V6	1996	1998	—	KGM10
4.3	262	V6	1999	2004	—	KGM10
<i>SSR</i>						
6.0	366	V8	2005	2006	Sold as Kit Only	GMK1023
<i>TRACKER</i>						
1.6	98	L4	1998	1998	—	04137
1.6	98	L4	1999	2000	—	GMK1044
2.0	122	L4	1999	2003	—	KSZ04

2

EXEDY OEM	Disc (mm)	Disc (in)	Spline Dia	Splines	Master Cylinder	Slave Cylinder	Clutch Cable	Clutch Fork	New Flywheel
—	302	11-7/8	1-1/8	10	MC379	SC746	—	—	FWGMC126
—	300	11-3/4	1-1/8	10	MC379	SC746	—	—	FWGMC01
—	300	11-3/4	1-1/8	10	MC379	SC746	—	—	FWGMC01
—	300	11-3/4	1-1/8	10	—	—	—	—	—
—	300	11-3/4	1-1/8	10	—	—	—	—	—
—	300	11-3/4	1-1/8	10	—	—	—	—	—
—	302	11-7/8	1-1/8	10	—	—	—	—	—
—	300	11-3/4	1-1/8	10	—	—	—	—	—
—	302	11-7/8	1-1/8	10	—	—	—	—	—
—	300	11-3/4	1-1/8	10	—	—	—	—	FWGM102
—	302	11-7/8	1-1/8	10	—	—	—	—	FWGM102
—	300	11-3/4	1-1/8	10	MC309	SC827	—	—	FWGM102
—	302	11-7/8	1-1/8	10	MC309	SC827	—	—	FWGM102
—	300	11-3/4	1-1/8	10	—	SC827	—	—	FWGM102
—	302	11-7/8	1-1/8	10	—	SC827	—	—	FWGM102
—	300	11-3/4	1-1/8	10	MC372	SC827	—	—	FWGM118
—	302	11-7/8	1-1/8	10	MC372	SC827	—	—	FWGM118
—	300	11-3/4	1-1/8	10	MC380	SC827	—	—	FWGM118
—	302	11-7/8	1-1/8	10	MC380	SC827	—	—	FWGM118
—	302	11-7/8	1-1/8	10	—	—	—	—	—
—	302	11-7/8	1-1/8	10	—	—	—	—	FWGMC126
Y	228	9	1	14	—	—	—	—	—
—	232	9-1/8	1	14	—	—	—	—	—
Y	228	9	1	14	MC486	SC705	—	—	—
—	232	9-1/8	1	14	MC486	SC705	—	—	—
—	232	9-1/8	1-1/8	26	MC376	SC742	—	CF128	—
Y	232	9-1/8	1-1/8	26	MC378	SC746	—	—	—
Y	228	9	1	14	MC308	SC705	—	CF128	FWGM115
—	232	9-1/8	1	14	MC308	SC705	—	CF128	FWGM115
Y	228	9	1	14	MC308	SC705	—	CF126	FWGM115
—	232	9-1/8	1	14	MC308	SC705	—	CF126	FWGM115
Y	228	9	1	14	MC373	SC742	—	CF126	FWGM115
—	232	9-1/8	1	14	MC373	SC742	—	CF126	FWGM115
Y	228	9	1	14	MC308	SC705	—	—	FWGM115
—	232	9-1/8	1	14	MC308	SC705	—	—	FWGM115
Y	228	9	1	14	MC308	SC705	—	CF126	FWGM115
—	232	9-1/8	1	14	MC308	SC705	—	CF126	FWGM115
Y	228	9	1	14	MC373	SC742	—	CF126	FWGM115
—	232	9-1/8	1	14	MC373	SC742	—	CF126	FWGM115
—	280	11	1-1/8	10	MC309	SC827	—	—	FWGM108
—	280	11	1-1/8	10	MC308	SC745	—	—	FWGM108
—	280	11	1-1/8	10	MC373	SC743	—	—	FWGM108
—	280	11	1-1/8	10	MC376	SC743	—	—	FWGM108
—	280	11	1-1/8	10	MC378	SC746	—	—	FWGM108
—	280	11	1-1/8	10	MC378	SC746	—	—	—
—	290	11-7/16	1-1/8	26	—	—	—	—	—
Y	215	8-7/16	7/8	20	MC503	SC870	—	—	—
Y	215	8-7/16	7/8	20	—	—	—	—	—
—	225	8-7/8	15/16	20	MC503	SC870	—	—	—

Liter	CC/IN	Cyl	Years		Application Information	Kit
			To	From		
CHRYSLER						
<i>300</i>						
6.3	384	V8	1962	1966	10-3/8" Disc	05029
6.8	415	V8	1959	1965	10-3/8" Disc	05029
<i>CIRRUS</i>						
2.0	122	L4	2000	2000	Modular Clutch Includes Flywheel	05085
<i>CROSSFIRE</i>						
3.2	195	V6	2004	2006	Sold as Kit Only, Includes CSC Hydraulic Slave Cylinder	CRK1009
<i>DAYTONA</i>						
2.5	153	L4	1987	1989	—	05028A
<i>LASER</i>						
2.2	134	L4	1984	1986	Non-Turbo, Sold As Kit Only	05028A
<i>LEBARON</i>						
2.2	134	L4	1982	1989	Non-Turbo, Sold As Kit Only	05028A
<i>NEWPORT, NEW YORKER, SARATOGA, WINDSOR, 300</i>						
5.9	360	V8	1961	1964	10-3/8" Disc	05029
5.9	360	V8	1971	1971	10-3/8" Disc	05029
6.3	384	V8	1959	1961	10-3/8" Disc	05029
6.3	384	V8	1965	1967	10-3/8" Disc	05029
6.3	384	V8	1968	1969	—	05032
6.8	415	V8	1959	1965	10-3/8" Disc	05029
<i>PT CRUISER</i>						
2.4	146	L4	2001	2005	Non-Turbo	KCH05
2.4	146	L4	2003	2005	Turbo, Includes Slave Cylinder, Sold as Kit Only	CRK1000
2.4	146	L4	2005	2005	Turbo, Transmission# 5273472AA, Includes Slave cylinder	CRK1012
2.4	146	L4	2006	2006	Non-Turbo	KCH05
2.4	146	L4	2006	2006	Turbo, Transmission# 5274888AC or 5274888AD , Includes Slave cylinder	CRK1000
2.4	146	L4	2006	2006	Turbo, Includes Slave Cylinder, Sold as Kit Only	CRK1012
<i>SEBRING</i>						
2.0	122	L4	1995	1999	Modular Clutch Includes Flywheel	05085
2.4	146	L4	2003	2003	Sold As Kit Only	05048
2.4	146	L4	2004	2004	Sold As Kit Only	05048
3.0	183	V6	2001	2003	Silent Design Disc, Pull Type, Sold As Kit Only	KMB03
3.0	183	V6	2004	2004	Silent Design Disc, Pull Type, Sold As Kit Only	KMB03
DAEWOO						
<i>LANOS</i>						
1.6	98	L4	1999	2000	From Chassis # E182493, Sold As Kit Only	DWK1000
<i>LEGANZA</i>						
2.2	134	L4	1999	2002	Sold As Kit Only	DWK1001
<i>NUBIRA</i>						
2.0	2000	L4	1999	2002	Sold As Kit Only	DWK1001
DAIHATSU						
<i>CHARADE</i>						
1.0	61	L3	1988	1992	—	23001
1.3	79	L4	1989	1992	—	23002
<i>ROCKY</i>						
1.6	98	L4	1990	1992	—	23003
DODGE (Performance Applications Available)						
<i>2000 GTX (CANADA)</i>						
2.0	122	L4	1989	1989	—	05051
<i>ARIES, DAYTONA, LANCER, SHADOW, SPIRIT, 400, 600</i>						
2.2	134	L4	1981	1989	Non-Turbo, Sold As Kit Only	05028A
2.2	134	L4	1990	1990	Non-Turbo	05061
2.2	134	L4	1991	1994	Non-Turbo	05059
2.5	153	L4	1986	1989	Non-Turbo, Sold As Kit Only	05028A

2

EXEDY OEM	Disc (mm)	Disc (in)	Spline Dia	Splines	Master Cylinder	Slave Cylinder	Clutch Cable	Clutch Fork	New Flywheel
—	263	10-3/8	1	23	—	—	—	—	—
—	263	10-3/8	1	23	—	—	—	—	—
—	230	9-1/16	15/16	17	—	—	—	—	—
—	240	9-7/16	1-1/8	26	—	—	—	—	—
—	215	8-7/16	13/16	18	—	—	—	—	—
—	215	8-7/16	13/16	18	—	—	—	—	—
—	215	8-7/16	13/16	18	—	—	—	—	—
—	263	10-3/8	1	23	—	—	—	—	—
—	263	10-3/8	1	23	—	—	—	—	—
—	263	10-3/8	1	23	—	—	—	—	—
—	263	10-3/8	1	23	—	—	—	—	—
—	280	11	1	23	—	—	—	—	FWCHR106
—	263	10-3/8	1	23	—	—	—	—	—
—	230	9-1/16	15/16	17	MC349	SC726	—	—	—
—	240	9-1/2	1-1/8	26	MC349	SC726	—	—	—
—	240	9-1/2	1-1/8	26	MC349	SC935	—	—	—
—	230	9-1/16	15/16	17	MC349	SC926	—	—	—
—	240	9-1/2	1-1/8	26	—	—	—	—	—
—	240	9-1/2	1-1/8	26	MC349	SC936	—	—	—
—	230	9-1/16	15/16	17	MC401	SC592	—	—	—
Y	225	8-7/8	7/8	20	MC565	SC844	—	—	MBF500
Y	225	8-7/8	7/8	20	—	—	—	—	MBF500
Y	230	9-1/16	15/16	23	MC564	SC854	—	—	—
Y	230	9-1/16	15/16	23	—	—	—	—	—
—	215	8-7/16	13/16	24	MC508	SC836	—	—	—
—	225	8-7/8	13/16	24	MC508	SC836	—	—	—
—	225	8-7/8	13/16	24	—	SC836	—	—	—
Y	170	6-11/16	7/8	20	—	—	—	—	—
—	180	7-1/8	7/8	20	—	—	—	—	—
—	200	7-7/8	7/8	20	—	—	—	—	—
Y	215	8-1/2	7/8	20	—	—	—	—	—
—	215	8-7/16	13/16	18	—	—	—	—	—
—	215	8-7/16	13/16	18	—	—	—	—	—
—	215	8-7/16	13/16	17	—	—	—	—	—
—	215	8-7/16	13/16	18	—	—	—	—	—

2

Liter	CC/IN	Cyl	Years		Application Information	Kit
			To	From		

DODGE (Performance Applications Available) continued

ASPEN, CORONET, DART, DIPLOMAT, LANCER, MONACO, POLARA, ROYAL, ROYAL MONACO

4.5	275	V8	1964	1966	10-3/8" Disc	05029
5.2	317	V8	1961	1978	10-3/8" Disc	05029
5.6	342	V8	1968	1971	10-3/8" Disc	05029
5.9	360	V8	1971	1971	10-3/8" Disc	05029
6.3	384	V8	1963	1969	10-3/8" Disc	05029
6.3	384	V8	1969	1969	11" Disc	05016

AVENGER

2.0	122	L4	1995	1999	Modular Clutch Includes Flywheel	05085
2.5	153	V6	1996	1998	Sold As Kit Only	05028A

CALIBER

1.8	110	L4	2007	2009	Sold as Kit Only, Includes CSC Hydraulic Slave Cylinder, Modular unit	CRK1017
-----	-----	----	------	------	---	---------

CHALLENGER

1.6	98	L4	1978	1979	FWD	05020
2.6	159	L4	1978	1983	—	05041
5.2	317	V8	1970	1974	10-3/8" Disc	05029
5.6	342	V8	1970	1973	10-3/8" Disc	05029

CHARGER, OMNI

2.2	134	L4	1981	1989	FWD, Non-Turbo, Sold As Kit Only	05028A
2.2	134	L4	1990	1990	FWD, Non-Turbo	05061
5.2	317	V8	1967	1974	10-3/8" Disc	05029
5.2	317	V8	1968	1968	10-3/8" Disc	05029
5.6	342	V8	1971	1973	10-3/8" Disc	05029
6.3	384	V8	1967	1969	10-3/8" Disc	05029
6.3	384	V8	1969	1969	11" Disc	05032

COLT

1.4	85	L4	1979	1979	4 Spd 7-7/8" Disc	05026
1.4	85	L4	1979	1979	Dual Range 4 Spd	05023
1.4	85	L4	1980	1980	4 Spd Luk	05026
1.4	85	L4	1980	1980	Dual Range 4 Spd Luk	05023
1.4	85	L4	1981	1984	4 Spd 7-7/8" Disc	05026
1.4	85	L4	1981	1984	Dual Range 4 Spd	05023
1.5	92	L4	1985	1988	4 Spd	05026
1.5	92	L4	1985	1988	5 Spd	05023
1.5	92	L4	1989	1994	—	05026
1.6	98	L4	1971	1972	—	05040
1.6	98	L4	1973	1973	From 10/73	05020
1.6	98	L4	1973	1973	To 9/73	05040
1.6	98	L4	1974	1978	—	05020
1.6	98	L4	1979	1979	Sedan	05023
1.6	98	L4	1979	1981	Sedan, 7-1/4" disc	05023
1.6	98	L4	1979	1981	Wagon	05020
1.6	98	L4	1982	1983	—	05023
1.6	98	L4	1984	1984	Turbo	05022
1.6	98	L4	1985	1985	Turbo 3 Speed and 5 Speed	05026
1.6	98	L4	1986	1988	Turbo 3 Speed and 5 Speed	05026
1.6	98	L4	1989	1990	5 Spd	05051
1.6	98	L4	1989	1990	Turbo, 5 Spd	05051
1.8	110	L4	1989	1990	—	05051
1.8	110	L4	1992	1992	—	05051
1.8	110	L4	1993	1994	—	05051
2.0	122	L4	1974	1977	—	05021
2.6	159	L4	1978	1980	—	05041

2

EXEDY OEM	Disc (mm)	Disc (in)	Spline Dia	Splines	Master Cylinder	Slave Cylinder	Clutch Cable	Clutch Fork	New Flywheel
—	263	10-3/8	1	23	—	—	—	—	—
—	263	10-3/8	1	23	—	—	—	—	—
—	263	10-3/8	1	23	—	—	—	—	—
—	263	10-3/8	1	23	—	—	—	—	—
—	263	10-3/8	1	23	—	—	—	—	—
—	280	11	1	23	—	—	—	—	FWCHR106
—	230	9-1/16	15/16	17	MC401	SC592	—	—	—
—	215	8-7/16	13/16	18	—	—	—	—	—
—	230	9-1/16	15/16	17	—	—	—	—	—
—	200	7-7/8	7/8	20	—	—	—	—	—
Y	225	8-7/8	1-1/32	23	—	—	—	—	—
—	263	10-3/8	1	23	—	—	—	—	—
—	263	10-3/8	1	23	—	—	—	—	—
—	215	8-7/16	13/16	18	—	—	—	—	—
—	215	8-7/16	13/16	18	—	—	—	—	—
—	263	10-3/8	1	23	—	—	—	—	—
—	263	10-3/8	1	23	—	—	—	—	—
—	263	10-3/8	1	23	—	—	—	—	—
—	263	10-3/8	1	23	—	—	—	—	—
—	280	11	1	23	—	—	—	—	FWCHR106
Y	200	7-7/8	7/8	20	—	—	—	—	—
Y	184	7-1/4	7/8	20	—	—	—	—	—
Y	200	7-7/8	7/8	20	—	—	—	—	—
Y	184	7-1/4	7/8	20	—	—	—	—	—
Y	200	7-7/8	7/8	20	—	—	—	—	—
Y	184	7-1/4	7/8	20	—	—	—	—	—
Y	200	7-7/8	7/8	20	—	—	—	—	—
Y	184	7-1/4	7/8	20	MC194	SC580	—	—	—
Y	200	7-7/8	7/8	20	MC178	SC580	—	—	—
—	200	7-7/8	7/8	20	—	—	—	—	—
—	200	7-7/8	7/8	20	—	—	—	—	—
—	200	7-7/8	7/8	20	—	—	—	—	—
—	200	7-7/8	7/8	20	—	—	—	—	—
Y	184	7-1/4	7/8	20	—	—	—	—	—
Y	184	7-1/4	7/8	20	—	—	—	—	—
—	200	7-7/8	7/8	20	—	—	—	—	—
Y	184	7-1/4	7/8	20	—	—	—	—	—
Y	200	7-7/8	7/8	20	MC203	SC580	—	—	—
Y	200	7-7/8	7/8	20	—	—	—	—	—
Y	200	7-7/8	7/8	20	MC497	SC584	—	—	—
Y	215	8-1/2	7/8	20	MC178	SC581	—	—	—
Y	215	8-1/2	7/8	20	MC178	SC581	—	—	—
Y	215	8-1/2	7/8	20	MC178	SC581	—	—	—
Y	215	8-1/2	7/8	20	—	SC581	—	—	—
Y	215	8-1/2	7/8	20	MC178	SC589	—	—	—
—	215	8-1/2	7/8	20	—	—	—	—	—
Y	225	8-7/8	1-1/32	23	—	—	—	—	—

Liter	CC/IN	Cyl	Years		Application Information	Kit
			To	From		
DODGE (Performance Applications Available) continued						
<i>COLT VISTA</i>						
2.0	122	L4	1984	1984	—	05026
2.0	122	L4	1985	1985	4WD	05051
2.0	122	L4	1985	1985	FWD with 7-7/8" Disc	05026
2.0	122	L4	1986	1987	2 WD with 7-7/8" Disc	05026
2.0	122	L4	1986	1991	4 WD	05051
2.0	122	L4	1987	1991	2 WD with 8-1/4" Disc	05051
<i>COLT VISTA (CANADA)</i>						
2.4	146	L4	1993	1994	4 WD, Sold As Kit Only	05048
<i>NEON</i>						
2.0	122	L4	1995	1999	11th Digit Vin is T	05076
2.0	122	L4	1996	2000	11th Digit Vin is D, Modular Clutch includes Flywheel	05085
2.0	122	L4	2001	2005	11th Digit Vin is D, Modular Clutch includes Flywheel	05085
2.4	146	L4	2003	2005	Turbo, Sold As Kit Only, Modular design incl. F/W	CRK1001
<i>STEALTH</i>						
3.0	183	V6	1991	1996	Non-Turbo, Sold As Kit Only	05048
3.0	183	V6	1991	1996	Turbo, Sold As Kit Only	05075
<i>STRATUS</i>						
2.0	122	L4	1995	2000	Modular Clutch Includes Flywheel	05085
2.4	146	L4	1997	1998	Modular Clutch Includes Flywheel	05085
2.4	146	L4	2001	2002	5 Spd with 16 Valve, Sold As Kit Only	MBK1000
2.4	146	L4	2003	2005	5 Spd with 16 Valve, Sold As Kit Only	MBK1000
3.0	183	V6	2001	2005	Silent Design Disc,Pot F/W, Sold As Kit Only, Fits R/T version 2001-03	KMB03
<i>VIPER</i>						
8.0	488	V10	1992	2002	—	05088
8.3	506	V10	2003	2006	—	05088
DODGE LIGHT TRUCK, SUV & VAN						
<i>100-350, 1500-2500 VAN</i>						
3.7	226	L6	1971	1980	11" Disc	05016
3.9	238	V6	1992	1993	—	05065
5.2	317	V8	1977	1983	10-3/8" Disc	05029
5.2	317	V8	1977	1987	11" Disc	05016
5.2	317	V8	1984	1987	10-3/8" Disc	05029
5.2	317	V8	1988	1991	A435 Trans	05038
5.2	317	V8	1992	1993	—	05063
5.9	360	V8	1971	1980	External Balanced Flywheel	05016
5.9	360	V8	1971	1980	Internal Balanced Flywheel	05016
6.6	403	V8	1971	1978	—	05062
7.2	439	V8	1974	1978	—	05062
<i>CARAVAN, MINI RAM</i>						
2.6	159	L4	1984	1987	—	05041
<i>D100-350, R1500-3500 (RAM), W100-350</i>						
3.7	226	L6	1969	1983	11" Disc	05016
3.7	226	V6	2002	2004	—	CRK1010
3.7	226	V6	2006	2006	—	CRK1010
3.9	238	V6	1988	1991	4 Spd	05038
3.9	238	V6	1989	1991	4 Spd	05038
3.9	238	V6	1992	1993	—	05065
3.9	238	V6	2001	2001	Sold as Kit Only	CRK1010
4.7	287	V8	2004	2004	Sold as Kit Only	CRK1010
4.7	287	V8	2005	2007	Sold as Kit Only	CRK1010
4.7	287	V8	2002	2004	Sold as Kit Only	CRK1010
4.7	287	V8	2005	2005	Sold as Kit Only	CRK1010
5.2	317	V8	1966	1980	11" Disc	05016
5.2	317	V8	1977	1980	10-3/8" Disc	05029
5.2	317	V8	1981	1985	10-3/8" Disc	05029

2

EXEDY OEM	Disc (mm)	Disc (in)	Spline Dia	Splines	Master Cylinder	Slave Cylinder	Clutch Cable	Clutch Fork	New Flywheel
Y	200	7-7/8	7/8	20	—	—	—	—	—
Y	215	8-1/2	7/8	20	MC175	SC583	—	—	—
Y	200	7-7/8	7/8	20	MC175	SC820	—	—	—
Y	200	7-7/8	7/8	20	MC175	SC581	—	—	—
Y	215	8-1/2	7/8	20	MC175	SC820	—	—	—
Y	215	8-1/2	7/8	20	MC175	SC581	—	—	—
Y	225	8-7/8	7/8	20	—	SC589	—	—	—
—	230	9-1/16	15/16	17	—	—	—	—	—
—	230	9-1/16	15/16	17	—	—	—	—	—
—	230	9-1/16	15/16	17	MC460	SC726	—	—	—
—	240	9-1/2	15/16	17	MC464	SC804	—	—	—
Y	225	8-7/8	7/8	20	MC543	SC837	—	—	—
—	250	9-7/8	1	23	MC544	SC838	—	—	—
—	230	9-1/16	15/16	17	—	—	—	—	—
—	230	9-1/16	15/16	17	—	—	—	—	—
Y	225	8-7/8	7/8	20	—	—	—	—	MBF500
Y	225	8-7/8	7/8	20	MC565	SC844	—	—	MBF500
Y	230	9-1/16	13/16	23	MC564	SC854	—	—	—
—	311	12-1/4	1-1/8	26	MC424	SC781	—	—	—
—	311	12-1/4	1-1/8	26	—	SC781	—	—	—
—	280	11	1	23	—	—	—	—	—
—	265	10-1/2	1-1/8	10	MC385	SC751	—	—	—
—	263	10-3/8	1	23	—	—	—	CF115	—
—	280	11	1	23	—	—	—	—	FWCHR106
—	263	10-3/8	1	23	MC383	SC750	—	CF115	—
—	280	11	1	23	MC386	SC749	—	—	FWCHR106
—	280	11	1	19	MC386	SC752	—	—	FWCHR106
—	280	11	1	23	—	—	—	—	FWCHR108
—	280	11	1	23	—	—	—	—	FWCHR106
—	302	11-7/8	1	23	—	—	—	—	—
—	302	11-7/8	1	23	—	—	—	—	—
Y	225	8-7/8	1-1/32	23	—	—	—	—	—
—	280	11	1	23	—	—	—	—	—
—	302	11-7/8	1-1/8	10	MC457	SC800	—	—	—
—	302	11-7/8	1-1/8	10	MC457	SC791	—	—	—
—	280	11	1	23	MC386	SC749	—	—	FWCHR106
—	280	11	1	23	MC386	—	—	—	FWCHR106
—	265	10-1/2	1-1/8	10	MC386	SC752	—	—	—
—	302	11-7/8	1-1/8	10	MC395	SC757	—	—	—
—	302	11-7/8	1-1/8	10	MC457	SC800	—	—	—
—	302	11-7/8	1-1/8	10	MC457	SC791	—	—	—
—	302	11-7/8	1-1/8	10	MC457	SC800	—	—	—
—	302	11-7/8	1-1/8	10	MC457	SC791	—	—	—
—	280	11	1	23	—	—	—	—	—
—	263	10-3/8	1	23	—	—	—	—	—
—	263	10-3/8	1	23	—	—	—	CF115	—

2

Liter	CC/IN	Cyl	Years		Application Information	Kit
			To	From		
DODGE LIGHT TRUCK, SUV & VAN continued						
<i>D100-350, R1500-3500 (RAM), W100-350 continued</i>						
5.2	317	V8	1981	1985	11" Disc	05016
5.2	317	V8	1986	1987	10-3/8" Disc	05029
5.2	317	V8	1988	1991	—	05038
5.2	317	V8	1992	1993	—	05063
5.2	317	V8	1994	1997	—	05074
5.2	317	V8	1998	2000	—	05074
5.2	317	V8	2001	2001	—	CRK1010
5.7	348	V8	2003	2008	Sold as Kit Only	CRK1008
5.9	360	V8	1971	1980	External Balanced Flywheel	05016
5.9	360	V8	1971	1980	Internal Balanced Flywheel	05016
5.9	360	V8	1981	1985	External Balanced Flywheel	05016
5.9	360	V8	1981	1985	Internal Balanced Flywheel	05016
5.9	360	V8	1986	1987	External Balanced Flywheel	05016
5.9	360	V8	1986	1987	Internal Balanced Flywheel	05016
5.9	360	V8	1988	1991	External Balanced Flywheel	05038
5.9	360	V8	1988	1991	Internal Balanced Flywheel	05038
5.9	360	V8	1993	1993	External Balanced Flywheel	05063
5.9	360	V8	1993	1993	Internal Balanced Flywheel	05063
5.9	360	L6	1994	1997	Turbo Diesel	05073
5.9	360	V8	1994	1997	Replaces OE 11" System	05074
5.9	360	L6	1998	2000	Turbo Diesel	05092
5.9	360	V8	1998	2000	Replaces OE 11" System	05074
5.9	360	V8	2001	2001	Replaces OE 11" System	05074
5.9	360	L6	2001	2003	Turbo Diesel, 5 Spd	05092
5.9	360	L6	2001	2004	Turbo Diesel, 6 Spd, Economy version, contains Exedy parts	CRK1004
5.9	360	L6	2001	2004	Turbo Diesel, 6 Spd, HD Version contains Cushion Button disc suited for 680 ft. lbs./Torque at the wheel	CRK1004HD
5.9	360	L6	2001	2004	Turbo Diesel, 6 Spd	05101
5.9	360	L6	2001	2004	Turbo Diesel, 6 Spd	05101A
5.9	360	V8	2002	2002	Replaces OE 11" System	05074
5.9	360	L6	2002	2003	Turbo Diesel 5 Speed	05092
5.9	360	L6	2005	2009	6 Spd Turbo Diesel, Mercedes Trans, Includes Master and Slave Cylinder Hydraulic system, Sold as Kit Only	CRK1005FW
5.9	360	L6	2005	2009	6 Spd Turbo Diesel, Solid FW replacement for OEM Dual Mass FW, Includes Master and Slave Cylinder Hydraulic system, Includes Solid FW, Sold as kit only, HD Version contains Cushion Button disc suited for 680 ft. lbs./Torque at the wheel	CRK1005FWHD
5.9	360	L6	2005	2009	6 Spd Turbo Diesel, Includes Master and Slave Cylinder Hydraulic system, Sold as Kit Only	CRK1005FW
5.9	360	L6	2005	2009	6 Spd Turbo Diesel, Solid FW replacement for OEM Dual Mass FW, Includes Master and Slave Cylinder Hydraulic system, Includes Solid FW, Sold as kit only, HD Version contains Cushion Button disc suited for 680 ft. lbs./Torque at the wheel	CRK1005FWHD
6.3	384	V8	1969	1971	—	05062
6.6	403	V8	1971	1978	—	05062
6.7	409	L6	2007	2017	6 Spd Turbo Diesel, Sold as Kit Only	CRK1005FW
6.7	409	L6	2007	2017	6 Spd Turbo Diesel, Solid FW replacement for OEM Dual Mass FW, Includes Master and Slave Cylinder Hydraulic system, Includes Solid FW, Sold as kit only, HD Version contains Cushion Button disc suited for 680 ft. lbs./Torque at the wheel	CRK1005FWHD
7.2	439	V8	1973	1978	—	05062
8.0	488	V10	1994	1997	—	05073
8.0	488	V10	1998	2003	—	05092
8.3	506	V10	2004	2006	SRT-10	05088
<i>D50, RAM 50, POWER RAM 50</i>						
2.0	122	L4	1979	1980	—	05012
2.0	122	L4	1981	1983	—	05011
2.0	122	L4	1984	1986	—	05011
2.0	122	L4	1987	1989	—	05011
2.3	140	L4	1983	1983	Turbo Diesel	05025
2.3	140	L4	1983	1983	Turbo Diesel, From 10/83	05025
2.3	140	L4	1983	1983	Turbo Diesel, To 9/83	05025
2.3	140	L4	1984	1985	Turbo Diesel	05025
2.4	146	L4	1990	1993	—	05041

2

EXEDY OEM	Disc (mm)	Disc (in)	Spline Dia	Splines	Master Cylinder	Slave Cylinder	Clutch Cable	Clutch Fork	New Flywheel
—	280	11	1	23	—	—	—	CF115	—
—	263	10-3/8	1	23	MC382	SC750	—	CF115	—
—	280	11	1	23	MC386	SC749	—	—	FWCHR106
—	280	11	1	19	MC386	SC752	—	—	FWCHR106
—	302	11-7/8	1-1/8	10	MC391	SC752	—	—	—
—	302	11-7/8	1-1/8	10	MC395	SC757	—	—	—
—	302	11-7/8	1-1/8	10	MC395	SC757	—	—	—
—	290	11-7/16	1-1/8	10	MC457	SC791	—	—	—
—	280	11	1	23	—	—	—	—	FWCHR108
—	280	11	1	23	—	—	—	—	FWCHR106
—	280	11	1	23	MC382	SC750	—	CF115	FWCHR108
—	280	11	1	23	MC382	SC750	—	CF115	FWCHR106
—	280	11	1	23	MC386	SC749	—	CF115	FWCHR108
—	280	11	1	23	MC386	SC749	—	CF115	FWCHR106
—	280	11	1	23	MC386	SC752	—	—	FWCHR108
—	280	11	1	23	MC386	SC752	—	—	FWCHR106
—	280	11	1	19	MC386	SC752	—	—	FWCHR108
—	280	11	1	19	MC386	SC752	—	—	FWCHR106
—	311	12-1/4	1-1/4	10	MC391	SC755	—	—	—
—	302	11-7/8	1-1/8	10	MC391	SC752	—	—	—
—	311	12-1/4	1-1/4	10	MC395	SC757	—	—	—
—	302	11-7/8	1-1/8	10	MC395	SC757	—	—	—
—	302	11-7/8	1-1/8	10	MC395	SC791	—	—	—
—	311	12-1/4	1-1/4	10	MC395	SC757	—	—	—
—	330	13	1-3/8	10	MC395	SC757	—	—	LFW147
—	330	13	1-3/8	10	MC395	—	—	—	LFW147
—	330	13	1-3/8	10	MC395	—	—	—	LFW147
—	330	13	1-3/8	10	MC395	—	—	—	LFW147
—	302	11-7/8	1-1/8	10	MC457	—	—	—	—
—	311	12-1/4	1-1/4	10	MC395	—	—	—	—
—	330	13	1-3/8	10	MC457	—	—	—	—
—	330	13	1-3/8	10	MC457	—	—	—	—
—	330	13	1-3/8	10	MC595	—	—	—	—
—	330	13	1-3/8	10	MC595	—	—	—	—
—	302	11-7/8	1	23	—	—	—	—	—
—	302	11-7/8	1	23	—	—	—	—	—
—	330	13	1-3/8	10	—	—	—	—	—
—	330	13	1-3/8	10	—	—	—	—	—
—	302	11-7/8	1	23	—	—	—	—	—
—	311	12-1/4	1-1/4	10	MC391	SC755	—	—	—
—	311	12-1/4	1-1/4	10	MC395	SC757	—	—	—
—	311	12-1/4	1-1/8	26	MC465	SC807	—	—	—
—	215	8-7/16	7/8	20	—	—	CC216	—	—
Y	215	8-7/16	7/8	23	—	—	CC216	—	—
Y	215	8-7/16	7/8	23	—	—	CC216	—	—
Y	215	8-7/16	7/8	23	—	—	—	—	—
Y	225	8-7/8	1-1/32	23	MC194	SC579	—	—	—
Y	225	8-7/8	1-1/32	23	MC176	SC579	—	—	—
Y	225	8-7/8	1-1/32	23	MC194	SC579	—	—	—
Y	225	8-7/8	1-1/32	23	MC176	SC579	—	—	—
Y	225	8-7/8	1-1/32	23	—	—	—	—	—

Liter	CC/IN	Cyl	Years		Application Information	Kit
			To	From		
DODGE LIGHT TRUCK, SUV & VAN continued						
<i>D50, RAM 50, POWER RAM 50 continued</i>						
2.6	159	L4	1979	1981	—	05052
2.6	159	L4	1982	1983	—	05025
2.6	159	L4	1984	1986	—	05041
2.6	159	L4	1987	1989	—	05041
3.0	183	V6	1990	1991	—	05050
DAKOTA						
2.5	153	L4	1992	1992	—	05066
2.5	153	L4	1993	1994	—	05070
2.5	153	L4	1995	1996	—	05070
2.5	153	L4	1997	1998	—	05089
2.5	153	L4	1999	2002	—	05104
3.7	226	V6	2004	2004	Sold as Kit Only	CRK1010
3.7	226	V6	2005	2007	Sold as Kit Only	CRK1010
3.9	238	V6	1992	1994	—	05065
3.9	238	V6	1995	1996	—	05065
3.9	238	V6	1997	1999	—	05065
3.9	238	V6	2001	2003	Sold as Kit Only	CRK1010
4.7	287	V8	2001	2006	Sold as Kit Only	CRK1010
4.7	287	V8	2007	2007	Sold as Kit Only	CRK1010
5.2	317	V8	1994	1994	—	5074
5.2	317	V8	1995	1996	—	5074
5.2	317	V8	1997	1999	—	5074
5.9	360	V8	2000	2000	—	5074
NITRO						
3.7	226	V6	2007	2007	Sold as Kit Only	CRK1006
RAIDER						
2.6	159	L4	1987	1989	—	05052
3.0	183	V6	1989	1989	—	05050
EAGLE						
<i>2000GTX (CANADA)</i>						
2.0	122	L4	1991	1991	—	05051
2.0	122	L4	1992	1992	2 WD	05071
2.0	122	L4	1992	1992	4 WD	05071
2.0	122	L4	1993	1993	2 WD	05071
2.0	122	L4	1993	1993	4 WD	05071
SUMMIT						
1.5	92	L4	1989	1991	7-1/4" Disc	05008
1.5	92	L4	1989	1994	—	05026
1.5	92	L4	1991	1992	CANADA	05008
1.5	92	L4	1996	1996	—	05026
1.6	98	L4	1989	1990	—	05026
1.8	110	L4	1992	1993	AWD & Wagon	05051
1.8	110	L4	1992	1993	Wagon	05051
1.8	110	L4	1992	1994	Except AWD & Wagon	05051
1.8	110	L4	1992	1994	FWD	05051
1.8	110	L4	1993	1994	FWD; Coupe	05051
1.8	110	L4	1996	1996	Except AWD & Wagon	05051
1.8	110	L4	1996	1996	FWD	05051
2.4	146	L4	1992	1992	Except AWD, Sold As Kit Only	05048
2.4	146	L4	1992	1994	AWD, Sold As Kit Only	05048
2.4	146	L4	1992	1994	FWD, Sold as Kit Only	05048
2.4	146	L4	1996	1996	AWD, Sold As Kit Only	05048
2.4	146	L4	1996	1996	FWD, Sold as Kit Only	05048

2

EXEDY OEM	Disc (mm)	Disc (in)	Spline Dia	Splines	Master Cylinder	Slave Cylinder	Clutch Cable	Clutch Fork	New Flywheel
Y	225	8-7/8	1-1/32	23	MC203	SC579	—	—	—
Y	225	8-7/8	1-1/32	23	—	—	CC216	—	—
Y	225	8-7/8	1-1/32	23	—	—	CC216	—	—
Y	225	8-7/8	1-1/32	23	—	—	—	—	—
Y	240	9-1/2	1-1/8	14	MC176	SC585	—	—	—
—	232	9-1/8	1	19	MC384	SC751	—	—	—
—	232	9-1/8	1-1/8	10	MC384	SC751	—	—	—
—	232	9-1/8	1-1/8	10	MC393	SC751	—	—	—
—	232	9-1/8	1-1/8	14	MC394	SC756	—	—	—
—	232	9-1/8	1-1/8	19	MC394	SC756	—	—	—
—	302	11-7/8	1-1/8	10	MC602	SC756	—	—	—
—	302	11-7/8	1-1/8	10	MC602	SC754	—	—	—
—	265	10-1/2	1-1/8	10	MC384	SC751	—	—	—
—	265	10-1/2	1-1/8	10	MC393	SC751	—	—	—
—	265	10-1/2	1-1/8	10	MC394	SC756	—	—	—
—	302	11-7/8	1-1/8	10	MC394	SC756	—	—	—
—	302	11-7/8	1-1/8	10	MC394	SC756	—	—	—
—	302	11-7/8	1-1/8	10	MC602	SC754	—	—	—
—	302	11-7/8	1-1/8	10	MC384	SC751	—	—	—
—	302	11-7/8	1-1/8	10	MC393	SC751	—	—	—
—	302	11-7/8	1-1/8	10	MC394	SC756	—	—	—
—	302	11-7/8	1-1/8	10	MC394	SC756	—	—	—
—	265	10-7/16	1-1/8	10	—	—	—	—	—
Y	225	8-7/8	1-1/32	23	MC497	SC579	—	—	—
Y	240	9-1/2	1-1/8	14	MC497	SC585	—	—	—
Y	215	8-1/2	7/8	20	—	—	—	—	—
Y	225	8-7/8	7/8	20	MC179	SC581	—	—	—
Y	225	8-7/8	7/8	20	MC179	SC584	—	—	—
Y	225	8-7/8	7/8	20	MC179	SC581	—	—	—
Y	225	8-7/8	7/8	20	MC179	SC584	—	—	—
—	184	7-1/4	7/8	20	MC178	SC584	—	—	—
Y	200	7-7/8	7/8	20	MC178	SC580	—	—	—
—	184	7-1/4	7/8	20	MC178	SC584	—	—	—
Y	200	7-7/8	7/8	20	MC178	SC589	—	—	—
Y	200	7-7/8	7/8	20	MC178	SC581	—	—	—
Y	215	8-1/2	7/8	20	MC183	SC915	—	—	—
Y	215	8-1/2	7/8	20	MC178	SC589	—	—	—
Y	215	8-1/2	7/8	20	MC178	SC589	—	—	—
Y	215	8-1/2	7/8	20	MC183	SC589	—	—	—
Y	215	8-1/2	7/8	20	MC183	SC589	—	—	—
Y	215	8-1/2	7/8	20	MC178	SC589	—	—	—
Y	215	8-1/2	7/8	20	MC183	SC589	—	—	—
Y	215	8-1/2	7/8	20	MC183	SC589	—	—	—
Y	215	8-1/2	7/8	20	MC183	SC589	—	—	—
Y	225	8-7/8	7/8	20	MC183	SC589	—	—	—
Y	225	8-7/8	7/8	20	MC183	SC584	—	—	—
Y	225	8-7/8	7/8	20	MC183	SC584	—	—	—
Y	225	8-7/8	7/8	20	MC183	SC584	—	—	—
Y	225	8-7/8	7/8	20	MC183	SC584	—	—	—
Y	225	8-7/8	7/8	20	MC183	SC584	—	—	—

2

Liter	CC/IN	Cyl	Years		Application Information	Kit
			To	From		
EAGLE continued						
<i>TALON</i>						
1.8	110	L4	1993	1994	—	05026
2.0	122	L4	1990	1991	Non-Turbo, without Speed Control	05051
2.0	122	L4	1990	1991	Turbo, With Speed Control, Sold As Kit Only	05048
2.0	122	L4	1990	1991	Turbo, Without Speed Control, Sold As Kit Only	05048
2.0	122	L4	1992	1994	Non-Turbo, with Speed Control	05051
2.0	122	L4	1992	1994	Turbo, Sold As Kit Only	05048
2.0	122	L4	1995	1998	Non-Turbo, Modular Clutch Includes Flywheel	05085
2.0	122	L4	1995	1998	Turbo, Sold As Kit Only	05048
<i>VISTA (CANADA)</i>						
1.5	92	L4	1990	1991	—	05026
FIAT						
<i>BRAVA, 131</i>						
1.8	110	L4	1975	1978	Sold As Kit Only	KFI01
2.0	122	L4	1979	1981	Sold As Kit Only	KFI01
<i>SPIDER, 124</i>						
1.6	98	L4	1971	1973	Sold As Kit Only	KFI01
1.6	98	L4	1974	1974	Sold As Kit Only	KFI01
1.8	110	L4	1974	1978	Sold As Kit Only	KFI01
2.0	122	L4	1979	1981	Sold As Kit Only	KFI01
<i>STRADA, X19</i>						
1.5	92	L4	1979	1983	Sold As Kit Only	KFI01
2	FORD (Performance Applications Available)					
<i>ASPIRE</i>						
1.3	79	L4	1994	1997	—	07068
<i>CONTOUR</i>						
2.0	122	L4	1995	2000	Includes Slave Cylinder	07136
2.5	153	V6	1995	2000	Includes Slave Cylinder	07137
2.5	153	V6	1995	2000	Kit does not include Slave Cylinder	07137LB
<i>CUSTOM</i>						
3.7	226	L6	1958	1964	10" Disc	07014
3.7	226	L6	1958	1964	11" Lever Clutch	07027L
3.7	226	L6	1958	1964	11"Diaph Clutch	KFM10
3.9	238	L6	1968	1972	10" Disc	07014
3.9	238	L6	1968	1972	11" Lever Clutch	07027L
3.9	238	L6	1968	1972	11"Diaph Clutch	KFM10
<i>ESCORT, EXP, ZX2</i>						
1.8	110	L4	1991	1996	—	07074
1.9	116	L4	1988	1990	—	07069
1.9	116	L4	1991	1996	—	07075
2.0	122	L4	1997	2002	—	07083
<i>FAIRLANE, TORINO</i>						
3.6	220	V8	1962	1963	—	07014
4.1	250	L6	1969	1974	—	07014
4.3	262	V8	1963	1964	—	07014
4.7	287	V8	1966	1968	2 BBL	07014
5.0	305	V8	1968	1974	10" Disc	07014
5.0	305	V8	1968	1974	11" Disc	07027
5.8	351	V8	1969	1974	—	07027
6.4	391	V8	1966	1966	—	07027
6.4	391	V8	1967	1969	2 BBL	07027
<i>FAIRMONT, MAVERICK</i>						
2.3	140	L4	1978	1982	—	07003
2.3	140	L4	1983	1983	—	07003
4.1	250	L6	1974	1977	—	07014
5.0	305	V8	1973	1978	—	07014
5.0	305	V8	1979	1979	—	07005

EXEDY OEM	Disc (mm)	Disc (in)	Spline Dia	Splines	Master Cylinder	Slave Cylinder	Clutch Cable	Clutch Fork	New Flywheel
Y	200	7-7/8	7/8	20	MC180	SC581	—	—	—
Y	215	8-1/2	7/8	20	MC179	SC581	—	—	—
Y	225	8-7/8	7/8	20	MC180	SC587	—	—	—
Y	225	8-7/8	7/8	20	MC179	SC587	—	—	—
Y	215	8-1/2	7/8	20	MC180	SC581	—	—	—
Y	225	8-7/8	7/8	20	MC179	SC587	—	—	—
—	230	9-1/16	15/16	17	MC188	SC761	—	—	—
Y	225	8-7/8	7/8	20	MC188	SC589	—	—	—
Y	200	7-7/8	7/8	20	—	SC589	—	—	—
—	215	8-1/2	7/8	20	—	—	—	—	—
—	215	8-1/2	7/8	20	—	—	—	—	—
—	215	8-1/2	7/8	20	—	—	—	—	—
—	215	8-1/2	7/8	20	—	—	—	—	—
—	215	8-1/2	7/8	20	—	—	—	—	—
—	215	8-1/2	7/8	20	—	—	—	—	—
Y	180	7-1/8	3/4	18	—	—	—	—	—
—	240	9-1/2	1	23	MC119	—	—	—	—
—	240	9-1/2	1	23	MC119	—	—	—	FWFMC01
—	240	9-1/2	1	23	MC119	—	—	—	FWFMC01
—	254	10	1-1/16	10	—	SC846	—	—	—
—	280	11	1-1/16	10	—	SC846	—	—	—
—	280	11	1-1/16	10	—	SC846	—	—	—
—	254	10	1-1/16	10	—	SC846	—	—	—
—	280	11	1-1/16	10	—	SC846	—	—	—
—	280	11	1-1/16	10	—	SC846	—	—	—
Y	215	8-7/16	15/16	22	MC221	SC629	—	—	FWFME01
—	215	8-7/16	7/8	20	—	—	CC314	—	—
Y	200	7-7/8	7/8	20	MC221	SC839	—	—	—
Y	225	8-7/8	15/16	22	MC221	SC877	—	—	—
—	254	10	1-1/16	10	—	SC846	—	—	—
—	254	10	1-1/16	10	—	SC846	—	—	—
—	254	10	1-1/16	10	—	SC846	—	—	—
—	254	10	1-1/16	10	—	SC846	—	—	—
—	254	10	1-1/16	10	—	SC846	—	—	—
—	280	11	1-1/16	10	—	SC846	—	—	FWFM121
—	280	11	1-1/16	10	—	SC846	—	—	—
—	280	11	1-1/16	10	—	—	—	—	—
—	280	11	1-1/16	10	—	—	—	—	FWFM113
—	215	8-1/2	1-1/32	23	—	—	—	—	—
—	215	8-1/2	1-1/32	23	—	—	—	—	FWFM122
—	254	10	1-1/16	10	—	SC846	—	—	—
—	254	10	1-1/16	10	—	—	—	—	—
—	254	10	1-1/16	10	—	—	—	—	—

2

Liter	CC/IN	Cyl	Years		Application Information	Kit
			To	From		
FORD (Performance Applications Available) continued						
<i>FALCON</i>						
4.3	262	V8	1963	1964	—	07014
4.7	287	V8	1966	1968	—	07014
5.0	305	V8	1968	1970	4 BBL	07014
<i>FESTIVA</i>						
1.3	79	L4	1988	1993	—	07068
<i>FIESTA</i>						
1.6	97	L4	2011	2016	Includes Slave Cylinder	FMK1032
<i>FOCUS</i>						
2.0	122	L4	2000	2004	DOHC, ZTS, ZX3, Includes CSC Concentric Slave Cylinder	KFM01
2.0	122	L4	2000	2004	SOHC, LX, SE, Includes CSC Concentric Slave Cylinder	KFM02
2.0	122	L4	2002	2004	SVT,6spd, Kit includes Dual Mass FW and CSC Hydraulic Slave Cylinder	FMK1005
2.0	122	L4	2012	2017	Sold as Kit Only, Includes CSC Hydraulic Slave Cylinder	FMK1033
2.3	140	L4	2003	2007	Duratec, Sold as kit only, Must USE FWFMF06 with kit, Includes CSC Hydraulic Slave cylinder	FMK1009
2.3	140	L4	2003	2007	Duratec, Sold as kit only, Includes Solid FW, Includes CSC Hydraulic Slave cylinder	FMK1009FW
<i>FUSION</i>						
2.3	140	L4	2006	2007	Sold As Kit Only	FMK1004
2.3	140	L4	2008	2013	Sold As Kit Only	MZK1008
2.5	152	L4	2010	2012	Sold As Kit Only	MZK1008
<i>GALAXIE, GALAXIE 500</i>						
3.7	226	L6	1963	1964	10" Disc	07014
3.7	226	L6	1963	1964	11" Lever Clutch	07027L
3.7	226	L6	1963	1964	11"Diaph Clutch	KFM10
3.9	238	L6	1965	1972	10" Disc	07014
3.9	238	L6	1965	1972	11" Lever Clutch	07027L
3.9	238	L6	1965	1972	11"Diaph Clutch	KFM10
4.3	262	V8	1964	1964	—	07014
4.7	287	V8	1963	1967	—	07014
4.8	293	V8	1959	1962	10" Disc	07014
5.0	305	V8	1968	1970	11" Lever Clutch	07027L
5.0	305	V8	1968	1972	10" Disc	07014
5.0	305	V8	1968	1972	11" Diaph Clutch	KFM10
5.0	305	V8	1971	1972	11" Lever Clutch	07027L
5.8	351	V8	1963	1965	11" Diaph Clutch	KFM10
5.8	351	V8	1963	1965	11" Diaph Clutch	KFM10
5.8	351	V8	1963	1965	11" Lever Clutch	07027L
5.8	351	V8	1963	1965	11" Lever Clutch	07027L
5.8	351	V8	1969	1969	11" Diaph Clutch	KFM10
5.8	351	V8	1969	1969	11" Diaph Clutch	KFM10
5.8	351	V8	1969	1969	11" Lever Clutch	07027L
5.8	351	V8	1969	1969	11" Lever Clutch	07027L
5.8	351	V8	1970	1970	11" Clutch	KFM10
5.8	351	V8	1970	1970	11" Lever Clutch	07027L
5.8	351	V8	1971	1973	11" Diaph Clutch	KFM10
5.8	351	V8	1971	1973	11" Diaph Clutch	KFM10
5.8	351	V8	1971	1973	11" Lever Clutch	07027L
5.8	351	V8	1971	1973	11" Lever Clutch	07027L
6.4	391	V8	1963	1966	2 BBL	07027
6.4	391	V8	1967	1970	2 BBL	07027
6.4	391	V8	1971	1971	—	07027
<i>GRANADA, LTD II</i>						
2.3	140	L4	1981	1983	—	07003
4.1	250	L6	1975	1980	—	07016
4.2	256	V8	1980	1980	—	07016
5.0	305	V8	1975	1979	—	07016

2

EXEDY OEM	Disc (mm)	Disc (in)	Spline Dia	Splines	Master Cylinder	Slave Cylinder	Clutch Cable	Clutch Fork	New Flywheel
—	254	10	1-1/16	10	—	SC846	—	—	—
—	254	10	1-1/16	10	—	SC846	—	—	—
—	254	10	1-1/16	10	—	SC846	—	—	—
Y	180	7-1/8	3/4	18	—	—	—	—	—
—	219	8-5/8	13/16	17	—	BRG0107	—	—	—
—	228	9	1	23	MC304	—	—	—	—
—	219	8-5/8	13/16	17	MC304	—	—	—	FWFMF01
—	240	9-7/16	1	14	—	—	—	—	FWFMF07
—	240	9-7/16	1	23	—	BRG0223	—	—	—
—	225	8-7/8	1-3/16	23	—	—	—	—	FWFMF06
—	225	8-7/8	1-3/16	23	—	—	—	—	FWFMF06
Y	225	8-7/8	15/16	22	MC221	SC877	—	—	—
Y	230	9-1/16	15/16	22	—	—	—	—	—
Y	230	9-1/16	15/16	22	—	—	—	—	FMF536
—	254	10	1-1/16	10	—	SC846	—	—	—
—	280	11	1-1/16	10	—	SC846	—	—	—
—	280	11	1-1/16	10	—	SC846	—	—	—
—	254	10	1-1/16	10	—	SC846	—	—	—
—	280	11	1-1/16	10	—	SC846	—	—	—
—	280	11	1-1/16	10	—	SC846	—	—	—
—	254	10	1-1/16	10	—	SC846	—	—	—
—	254	10	1-1/16	10	—	SC846	—	—	—
—	280	11	1-1/16	10	—	—	—	—	FWFM113
—	254	10	1-1/16	10	—	SC846	—	—	—
—	280	11	1-1/16	10	—	SC846	—	—	FWFM113
—	280	11	1-1/16	10	—	—	—	—	—
—	280	11	1-1/16	10	—	—	—	—	—
—	280	11	1-1/16	10	—	SC846	—	—	—
—	280	11	1-1/16	10	—	—	—	—	—
—	280	11	1-1/16	10	—	SC846	—	—	—
—	280	11	1-1/16	10	—	—	—	—	FWFM113
—	280	11	1-1/16	10	—	—	—	—	FWFM113
—	280	11	1-1/16	10	—	—	—	—	—
—	280	11	1-1/16	10	—	SC846	—	—	—
—	280	11	1-1/16	10	—	—	—	—	—
—	280	11	1-1/16	10	—	SC846	—	—	—
—	280	11	1-1/16	10	—	—	—	—	—
—	280	11	1-1/16	10	—	—	—	—	FWFM113
—	280	11	1-1/16	10	—	—	—	—	—
—	215	8-1/2	1-1/32	23	—	—	—	—	—
—	254	10	1-1/16	10	—	—	—	—	—
—	254	10	1-1/16	10	—	—	—	—	—
—	254	10	1-1/16	10	—	—	—	—	—

Liter	CC/IN	Cyl	Years		Application Information	Kit
			To	From		
FORD (Performance Applications Available) continued						
<i>MUSTANG, MUSTANG II</i>						
2.3	140	L4	1974	1974	Non-Turbo, German 4 Spd	07003
2.3	140	L4	1974	1983	Non-Turbo, Ford 4 Spd	07030
2.3	140	L4	1979	1982	Turbo	07006
2.3	140	L4	1979	1983	German 4 spd	07003
2.3	140	L4	1980	1980	Non-Turbo, 5 Spd, 10/80-11/80	07006
2.3	140	L4	1980	1982	Non-Turbo, 5 Spd, From 12/80	07029
2.3	140	L4	1981	1982	Non-Turbo, German 4 Spd	07003
2.3	140	L4	1983	1983	Turbo, German 4 spd	07003
2.3	140	L4	1983	1986	5 Spd	07038
2.3	140	L4	1983	1986	Turbo, 5 Spd	07038
2.3	140	L4	1983	1986	Turbo, Ford 4 Spd	07030
2.3	140	L4	1984	1986	4 Spd	07003
2.3	140	L4	1984	1986	Turbo, 4 Spd	07003
2.3	140	L4	1987	1992	5 Spd	07030
2.3	140	L4	1993	1993	5 Spd	07030
3.8	232	V6	1994	1999	—	07114
3.8	232	V6	2000	2000	—	07114
3.8	232	V6	2001	2004	—	07114
4.0	244	V6	2005	2006	Sold as kit only	FMK1010
4.1	250	L6	1969	1973	—	07014
4.6	281	V8	1996	1999	Cobra	FMK1001
4.6	281	V8	1996	2001	GT	07042
4.6	281	V8	1999	2001	GT with T45 Transmission, Heavy Duty Version, Sold As Kit Only	KFM08HP
4.6	281	V8	2001	2003	GT with TR3650 Transmission, From 2/01	KFM09
4.6	281	V8	1999	2001	Cobra, T45 Transmission	KFM10
4.6	281	V8	1999	2001	Cobra, T45 Transmission, HD Version	KFM10HP
4.6	281	V8	2005	2010	GT, SHELBY GT, BULLIT, Sold as kit only, Includes CSC Hydraulic Slave cylinder, 10th spline	FMK1011
4.6	281	V8	2005	2010	GT, SHELBY GT, BULLIT, Sold as kit only, Includes CSC Hydraulic Slave cylinder, 26th spline	FMK1012
4.7	287	V8	1966	1967	—	07014
5.0	302	V8	1968	1973	—	07014
5.0	302	V8	1979	1979	—	07005
5.0	302	V8	1982	1985	—	07005
5.0	302	V8	1986	1995	—	07042
5.0	302	V8	1986	1995	GT with T45 Transmission, Sold As Kit Only	KFM08HP
5.0	302	V8	2011	2017	GT, Sold as Kit only, Includes CSC Hydraulic Slave cylinder	FMK1026
5.8	351	V8	1969	1973	11" Lever Clutch	07027L
<i>PINTO</i>						
2.0	122	L4	1971	1974	—	07003
2.3	140	L4	1974	1980	—	07003
<i>PROBE</i>						
2.0	122	L4	1993	1994	—	07094
2.0	122	L4	1995	1997	—	07094
2.2	134	L4	1989	1989	Turbo, with ABS	07067
2.2	134	L4	1989	1989	Turbo, without ABS	07067
2.2	134	L4	1989	1992	Non-Turbo	10029
2.2	134	L4	1989	1992	Non-Turbo with Heavy Duty Ductile Iron Cover	10029D
2.2	134	L4	1990	1990	Turbo, 4-Wheel ABS	07067
2.2	134	L4	1991	1992	Turbo, with ABS	07067
2.2	134	L4	1991	1992	Turbo, without ABS	07067
2.5	153	V6	1993	1997	—	07095
3.0	183	V6	1990	1992	With ABS	07072
3.0	183	V6	1990	1992	Without ABS	07072
<i>RANCHERO</i>						
4.1	250	L6	1970	1973	—	07014
5.0	305	V8	1968	1974	—	07014
5.8	354	V8	1970	1970	With Externally Balanced Flywheel	07027
5.8	354	V8	1970	1970	With Internally Balanced Flywheel	07027
5.8	351	V8	1971	1974	—	07027
6.4	391	V8	1967	1969	—	07027

EXEDY OEM	Disc (mm)	Disc (in)	Spline Dia	Splines	Master Cylinder	Slave Cylinder	Clutch Cable	Clutch Fork	New Flywheel
—	215	8-1/2	1-1/32	23	—	—	—	—	—
—	215	8-7/16	1-1/16	10	—	—	—	—	—
—	215	8-7/16	1-1/16	10	—	—	—	—	—
—	215	8-1/2	1-1/32	23	—	—	—	—	—
—	215	8-7/16	1-1/16	10	—	—	—	—	—
—	215	8-1/2	1-1/16	23	—	—	—	—	—
—	215	8-1/2	1-1/32	23	—	—	—	—	—
—	215	8-1/2	1-1/32	23	—	—	—	—	—
Y	225	8-7/8	1-1/16	10	—	—	—	—	—
Y	225	8-7/8	1-1/16	10	—	—	—	—	—
—	215	8-7/16	1-1/16	10	—	—	—	—	—
—	215	8-1/2	1-1/32	23	—	—	—	—	—
—	215	8-1/2	1-1/32	23	—	—	—	—	—
—	215	8-7/16	1-1/16	10	—	—	CC853	—	FWFM122
—	215	8-7/16	1-1/16	10	—	—	—	—	FWFM122
—	280	11	1-1/16	10	—	—	—	—	—
—	280	11	1-1/16	10	—	—	—	—	—
—	280	11	1-1/16	10	—	—	—	—	—
—	254	10	1-1/16	10	—	BRG0159	—	—	—
—	254	10	1-1/16	10	—	SC846	—	—	—
—	265	10-1/2	1-1/16	10	—	—	—	—	—
—	265	10-1/2	1-1/16	10	—	—	—	—	—
—	265	10-1/2	1-1/16	10	—	—	—	—	—
—	280	11	1-1/16	10	—	—	—	—	—
—	280	11	1-1/16	10	—	—	—	—	—
—	280	11	1-1/16	10	—	—	—	—	—
—	280	11	1-1/16	10	—	BRG0159	—	—	—
—	280	11	1-1/16	26	—	BRG0159	—	—	—
—	254	10	1-1/16	10	—	SC846	—	—	—
—	254	10	1-1/16	10	—	SC846	—	—	—
—	254	10	1-1/16	10	—	—	—	—	—
—	254	10	1-1/16	10	—	—	CC318	—	FWFM111
—	265	10-1/2	1-1/16	10	—	—	CC318	—	FWFM112/FMF500
—	265	10-1/2	1-1/16	10	—	—	—	—	FWFM112/FMF500
—	280	11	1	23	—	BRG0186	—	—	—
—	280	11	1-1/16	10	—	SC846	—	—	FWFM113
—	215	8-1/2	1-1/32	23	—	SC846	—	—	—
—	215	8-1/2	1-1/32	23	—	—	—	—	—
Y	215	8-1/2	15/16	22	MC213	SC630	—	—	FWFN1222
Y	215	8-1/2	15/16	22	MC213	SC630	—	—	—
Y	240	9-1/2	1-1/16	23	MC212	SC607	—	—	—
Y	240	9-1/2	1-1/16	23	MC211	SC607	—	—	—
Y	225	8-7/8	15/16	22	MC211	SC606	—	—	FMF512
Y	225	8-7/8	15/16	22	MC211	SC606	—	—	FMF512
Y	240	9-1/2	1-1/16	23	MC212	SC607	—	—	—
Y	240	9-1/2	1-1/16	23	MC212	SC607	—	—	—
Y	240	9-1/2	1-1/16	23	MC211	SC607	—	—	—
Y	225	8-7/8	15/16	22	MC213	SC630	—	—	—
Y	240	9-1/2	1-1/16	23	MC212	SC616	—	—	—
Y	240	9-1/2	1-1/16	23	MC211	SC616	—	—	—
—	254	10	1-1/16	10	—	SC846	—	—	—
—	254	10	1-1/16	10	—	SC846	—	—	—
—	280	11	1-1/16	10	—	—	—	—	FWFM116
—	280	11	1-1/16	10	—	—	—	—	FWFM113
—	280	11	1-1/16	10	—	—	—	—	FWFM116
—	280	11	1-1/16	10	—	SC846	—	—	—

Liter	CC/IN	Cyl	Years		Application Information	Kit
			To	From		
FORD (Performance Applications Available) continued						
<i>TEMPO</i>						
2.3	140	L4	1988	1994	—	07069
<i>THUNDERBIRD</i>						
2.3	140	L4	1983	1986	Turbo	07038
2.3	140	L4	1987	1988	Turbo	07038
FORD TRUCK, SUV & VAN						
<i>BRONCO, F100-550</i>						
3.8	232	V6	1982	1982	—	07014
3.8	232	V6	1983	1983	—	07016
3.9	238	L6	1966	1976	—	07027
4.2	256	V8	1981	1982	—	07014
4.2	256	V6	1997	1999	—	07129
4.2	256	V6	1997	1999	Non-Self Adjusting Clutch, EXEDY Economy version, Sold as Kit Only	FMK1021
4.2	256	V6	2000	2008	Self -Adjusting OEM version	KFM12
4.2	256	V6	2000	2004	Non-Self Adjusting Clutch, EXEDY Economy version, Sold as Kit Only	FMK1020
4.6	281	V8	1997	1998	—	KFM11
4.6	281	V8	1997	1998	Non-Self Adjusting Clutch, EXEDY Economy version, Sold as Kit Only	FMK1021
4.6	281	V8	1999	2004	—	KFM12
4.6	281	V8	1999	2004	Non-Self Adjusting Clutch, EXEDY Economy version, Sold as Kit Only	FMK1020
4.7	287	V8	1966	1966	10" Disc	07014
4.7	287	V8	1966	1967	11" Disc	07015
4.9	299	L6	1965	1972	—	07027
4.9	299	L6	1973	1976	—	07027
4.9	299	L6	1977	1977	11" Disc, From Chassis # Y80,001	07015
4.9	299	L6	1977	1977	To Chassis # Y80,000	07027
4.9	299	L6	1978	1979	11" Disc	07015
4.9	299	L6	1980	1982	10" Disc	07014
4.9	299	L6	1980	1982	11" Disc	07015
4.9	299	L6	1983	1983	Hydraulic Linkage	07016
4.9	299	L6	1983	1983	Mechanical Linkage	07013
4.9	299	L6	1984	1987	10" Disc	07016
4.9	299	L6	1984	1987	11" Disc	07032
4.9	299	L6	1988	1990	4 Spd with 10" Disc	07016
4.9	299	L6	1988	1990	4 Spd with 11" Disc	07032
4.9	299	L6	1988	1990	5 Spd with 10" Disc	07056
4.9	299	L6	1988	1990	5 Spd with 11" Disc	07057
4.9	299	L6	1991	1991	4 Spd with 10" Disc	07016
4.9	299	L6	1991	1991	4 Spd with 11" Disc	07032
4.9	299	L6	1991	1991	5 Spd with 11" Disc	07057
4.9	299	L6	1991	1992	5 Spd with 10" Disc	07056
4.9	299	L6	1992	1992	4 Spd with 10" Disc	07016
4.9	299	L6	1992	1992	4 Spd with 11" Disc	07032
4.9	299	L6	1992	1992	5 Spd with 11" Disc	07057
4.9	299	L6	1993	1993	4 Spd with 10" Disc	07016
4.9	299	L6	1993	1993	4 Spd with 11" Disc	07032
4.9	299	L6	1993	1996	5 Spd with 10" Disc	07098
4.9	299	L6	1993	1996	5 Spd with 11" Disc	07097
5.0	302	V8	1968	1976	—	07027
5.0	302	V8	1977	1977	From Chassis # Y 80, 001	07015
5.0	302	V8	1977	1977	To Chassis # Y80,000	07027
5.0	302	V8	1978	1979	—	07015
5.0	302	V8	1980	1982	10" Disc	07014
5.0	302	V8	1980	1983	11" Disc	07013
5.0	302	V8	1983	1983	10" Disc	07016
5.0	302	V8	1984	1986	10" Disc	07016
5.0	302	V8	1984	1986	11" Disc	07022
5.0	302	V8	1987	1987	—	07032
5.0	302	V8	1988	1989	4 Spd	07032

2

EXEDY OEM	Disc (mm)	Disc (in)	Spline Dia	Splines	Master Cylinder	Slave Cylinder	Clutch Cable	Clutch Fork	New Flywheel
—	215	8-7/16	7/8	20	—	—	—	—	FWFM122
Y	225	8-7/8	1-1/16	10	—	—	—	—	—
Y	225	8-7/8	1-1/16	10	MC301	SC700	—	—	—
—	254	10	1-1/16	10	—	—	—	—	—
—	254	10	1-1/16	10	—	—	—	—	—
—	280	11	1-1/16	10	—	SC846	—	—	—
—	254	10	1-1/16	10	—	—	—	—	FWFM123
—	290	11-1/2	1-1/16	10	MC366	SC778	—	—	—
—	290	11-1/2	1-1/16	10	MC366	SC778	—	—	—
—	290	11-1/2	1-1/16	10	MC366	SC778	—	—	FWFMC117
—	290	11-1/2	1-1/16	10	MC366	SC778	—	—	FWFMC117
—	290	11-1/2	1-1/16	10	MC366	SC778	—	—	—
—	290	11-1/2	1-1/16	10	MC366	SC778	—	—	—
—	290	11-1/2	1-1/16	10	MC366	SC778	—	—	—
—	290	11-1/2	1-1/16	10	MC366	SC778	—	—	—
—	254	10	1-1/16	10	—	—	—	—	—
—	280	11	1-1/16	10	—	SC846	—	—	—
—	280	11	1-1/16	10	—	—	—	—	—
—	280	11	1-1/16	10	—	—	—	CF101	—
—	280	11	1-1/16	10	—	—	—	CF101	—
—	280	11	1-1/16	10	—	—	—	CF101	—
—	280	11	1-1/16	10	—	—	—	CF101	—
—	254	10	1-1/16	10	—	—	—	—	FWFM117
—	280	11	1-1/16	10	—	—	—	—	FWFM117
—	254	10	1-1/16	10	MC357	SC729	—	—	FWFM117
—	280	11	1-1/16	10	MC442	SC788	—	—	FWFM117
—	254	10	1-1/16	10	MC357	SC728	—	CF117	FWFM117
—	280	11	1-1/16	10	MC357	SC728	—	CF117	FWFM117
—	254	10	1-1/16	10	MC355	SC728	—	CF117	FWFM117
—	280	11	1-1/16	10	MC355	SC728	—	CF117	FWFM117
—	254	10	1-1/16	10	MC355	SC783	—	CF117	FWFM117
—	280	11	1-1/16	10	MC355	SC783	—	CF117	FWFM117
—	254	10	1-1/16	10	MC355	SC728	—	—	FWFM117
—	280	11	1-1/16	10	MC355	SC728	—	—	FWFM117
—	280	11	1-1/16	10	MC355	SC783	—	—	FWFM117
—	254	10	1-1/16	10	MC355	SC783	—	—	FWFM117
—	254	10	1-1/16	10	MC361	SC728	—	—	FWFM117
—	280	11	1-1/16	10	MC361	SC728	—	—	FWFM117
—	280	11	1-1/16	10	MC361	SC783	—	—	FWFM117
—	254	10	1-1/16	10	MC429	SC734	—	—	FWFM117
—	280	11	1-1/16	10	MC429	SC734	—	—	FWFM117
—	254	10	1-1/16	10	MC429	SC778	—	—	FWFM117
—	280	11	1-1/16	10	MC429	SC778	—	—	FWFM117
—	280	11	1-1/16	10	—	—	—	—	FWFM116
—	280	11	1-1/16	10	—	—	—	—	—
—	280	11	1-1/16	10	—	—	—	—	FWFM116
—	254	10	1-1/16	10	—	—	—	—	—
—	280	11	1-1/16	10	—	—	—	—	FWFM116
—	254	10	1-1/16	10	MC357	—	—	—	—
—	254	10	1-1/16	10	MC357	SC788	—	—	—
—	280	11	1-1/16	10	MC357	SC728	—	—	FWFM116
—	280	11	1-1/16	10	MC357	SC728	—	—	FWFM116
—	280	11	1-1/16	10	MC355	SC728	—	—	—

Liter	CC/IN	Cyl	Years		Application Information	Kit
			To	From		

FORD TRUCK, SUV & VAN continued

BRONCO, F100-550 continued

5.0	302	V8	1988	1989	5 Spd	07057
5.0	302	V8	1990	1991	4 Spd	07032
5.0	302	V8	1990	1991	5 Spd	07057
5.0	302	V8	1992	1992	4 Spd	07032
5.0	302	V8	1992	1992	5 Spd	07057
5.0	302	V8	1993	1996	5 Spd	07097
5.4	330	V8	1999	2007	—	07144
5.8	351	V8	1966	1967	—	07027
5.8	351	V8	1977	1979	—	07033
5.8	351	V8	1980	1980	—	07033
5.8	351	V8	1981	1982	—	07015
5.8	351	V8	1983	1983	—	07013
5.8	351	V8	1984	1986	—	07016
5.8	351	V8	1987	1987	—	KFM04
5.8	351	V8	1988	1989	4 Spd	07032
5.8	351	V8	1988	1989	5 Spd	07057
5.8	351	V8	1990	1990	4 Spd	07032
5.8	351	V8	1990	1990	4 Spd	07032
5.8	351	V8	1990	1990	5 Spd	07057
5.8	351	V8	1990	1990	5 Spd	07057
5.8	351	V8	1991	1991	4 Spd	07032
5.8	351	V8	1991	1991	5 Spd	07057
5.8	351	V8	1992	1992	4 Spd	07032
5.8	351	V8	1992	1992	5 Spd	07057
5.8	351	V8	1993	1994	—	07097
5.8	351	V8	1995	1997	—	07117
5.9	360	V8	1968	1977	—	07027
6.0	366	V8	2003	2005	Turbo Diesel, Solid FW, Sold as Kit Only	FMK1016
6.0	366	V8	2005	2006	Turbo Diesel, Solid FW, Sold as Kit Only	FMK1016
6.0	366	V8	2007	2007	Turbo Diesel, Solid FW, Sold as Kit Only	FMK1016
6.4	391	V8	1968	1970	—	07027
6.4	391	V8	1968	1976	—	07027
6.6	403	V8	1977	1978	—	07050
6.6	403	V8	1979	1982	—	07050
6.8	415	V10	1999	2003	—	KFM21
6.8	415	V10	2004	2004	Sold as Kit Only	FMK1018
6.8	415	V10	2004	2005	Sold as Kit Only	FMK1018
6.8	415	V10	2005	2007	Sold as Kit Only	FMK1018
6.9	421	V8	1983	1986	Diesel, 11" Clutch with Solid Flywheel	07026
6.9	421	V8	1983	1986	Diesel, 12" Disc	07065
6.9	421	V8	1987	1987	Diesel, 4 Spd 11" Clutch with Solid Flywheel	07026
6.9	421	V8	1987	1987	Diesel, 4 Spd, 12" Disc	07065
7.3	445	V8	1988	1989	Diesel with Indirect Fuel Injection, Non-Turbo and Aftermarket Turbo, with DMF. Valeo type DMF included.	07076A
7.3	445	V8	1988	1989	Diesel with Indirect Fuel Injection, Non-Turbo and Aftermarket Turbo, with DMF. Valeo type DMF not included.	07076
7.3	445	V8	1988	1989	Diesel with Indirect Fuel Injection, Non-Turbo and Factory Turbo, 8th Digit of VIN K. LUK type solid flywheel replacement kit contains solid flywheel and mounting bolts. Must be used as matched set.	07131B
7.3	445	V8	1988	1989	Diesel, With Indirect Fuel Injection, 8th Digit of VIN# M, Non-Turbo and Aftermarket Turbo, LUK type solid flywheel replacement, kit contains flywheel.	07131A
7.3	445	V8	1988	1989	Diesel, With Indirect Fuel Injection, 8th Digit of VIN# M, Non-Turbo and Aftermarket Turbo, LUK type solid flywheel replacement, kit does not contain flywheel.	07131
7.3	445	V8	1990	1991	Diesel with Indirect Fuel Injection, Non-Turbo and Aftermarket Turbo, with DMF. Valeo type DMF included.	07076A
7.3	445	V8	1990	1991	Diesel with Indirect Fuel Injection, Non-Turbo and Aftermarket Turbo, with DMF. Valeo type DMF not included.	07076
7.3	445	V8	1990	1992	Diesel with Indirect Fuel Injection, Non-Turbo and Factory Turbo, Stripped Chassis, 8th Digit of VIN K. LUK type solid flywheel replacement, kit contains solid flywheel and mounting bolts. Must be used as matched set.	07131B

2

EXEDY OEM	Disc (mm)	Disc (in)	Spline Dia	Splines	Master Cylinder	Slave Cylinder	Clutch Cable	Clutch Fork	New Flywheel
—	280	11	1-1/16	10	MC355	SC728	—	—	—
—	280	11	1-1/16	10	MC355	SC783	—	—	—
—	280	11	1-1/16	10	MC355	SC783	—	—	—
—	280	11	1-1/16	10	MC361	SC783	—	—	—
—	280	11	1-1/16	10	MC361	SC783	—	—	—
—	280	11	1-1/16	10	MC429	SC778	—	—	—
—	305	12	1-1/4	10	MC368	SC739	—	—	—
—	280	11	1-1/16	10	—	SC846	—	—	—
—	280	11	1-1/16	10	—	—	—	—	—
—	280	11	1-1/16	10	—	—	—	CF107	—
—	280	11	1-1/16	10	—	—	—	CF107	—
—	280	11	1-1/16	10	—	—	—	—	—
—	254	10	1-1/16	10	MC357	SC728	—	—	—
—	280	11	1-1/16	10	MC357	SC728	—	—	—
—	280	11	1-1/16	10	MC355	SC728	—	—	—
—	280	11	1-1/16	10	MC355	SC728	—	—	—
—	280	11	1-1/16	10	MC355	SC783	—	—	—
—	280	11	1-1/16	10	MC355	SC788	—	—	—
—	280	11	1-1/16	10	MC355	SC783	—	—	—
—	280	11	1-1/16	10	MC355	SC788	—	—	—
—	280	11	1-1/16	10	MC355	SC783	—	—	—
—	280	11	1-1/16	10	MC355	SC783	—	—	—
—	280	11	1-1/16	10	MC361	SC783	—	—	—
—	280	11	1-1/16	10	MC361	SC783	—	—	—
—	280	11	1-1/16	10	MC429	SC778	—	—	—
—	305	12	1-1/16	10	MC429	SC778	—	—	—
—	280	11	1-1/16	10	—	SC846	—	—	—
—	330	13	1-3/8	10	MC591	SC929	—	—	FWFMF08
—	330	13	1-3/8	10	MC592	SC929	—	—	FWFMF08
—	330	13	1-3/8	10	—	—	—	—	FWFMF08
—	280	11	1-1/16	10	—	—	—	—	FWFM113
—	280	11	1-1/16	10	—	SC846	—	—	—
—	302	11-7/8	1-1/16	10	—	—	—	—	—
—	302	11-7/8	1-1/16	10	—	—	—	CF103	—
—	305	12	1-1/4	10	MC368	SC739	—	—	—
—	305	11-15/16	1-1/4	10	MC368	SC739	—	—	—
—	305	11-15/16	1-1/4	10	MC591 (6/04-2/05)	SC930	—	—	—
—	305	11-15/16	1-1/4	10	MC592 (3/05-on)	SC930	—	—	—
—	280	11	1-1/16	10	MC357	SC729	—	—	—
—	302	11-7/8	1-1/16	10	MC357	SC729	—	—	—
—	280	11	1-1/16	10	MC357	SC729	—	—	—
—	302	11-7/8	1-1/16	10	MC357	SC729	—	—	—
—	280	11	1-1/4	10	MC355	—	—	—	FWFTF01
—	280	11	1-1/4	10	MC355	—	—	—	FWFTF01
—	311	12-1/4	1-1/4	10	MC355	—	—	—	FWFMC128
—	311	12-1/4	1-1/4	10	MC355	—	—	—	FWFMC127
—	311	12-1/4	1-1/4	10	MC355	—	—	—	FWFMC127
—	280	11	1-1/4	10	MC356	—	—	—	FWFTF01
—	280	11	1-1/4	10	MC356	—	—	—	FWFTF01
—	311	12-1/4	1-1/4	10	MC356	—	—	—	FWFMC128

2

Liter	CC/IN	Cyl	Years		Application Information	Kit
			To	From		
FORD TRUCK, SUV & VAN continued						
<i>BRONCO, F100-550 continued</i>						
7.3	445	V8	1990	1992	Diesel,With Indirect Fuel Injection,8th Digit of VIN# M, Non-Turbo and Aftermarket Turbo, LUK type solid flywheel replacement, kit contains flywheel.	07131A
7.3	445	V8	1990	1992	Diesel,With Indirect Fuel Injection,8th Digit of VIN# M, Non-Turbo and Aftermarket Turbo, LUK type solid flywheel replacement, kit does not contain flywheel.	07131
7.3	445	V8	1990	1994	Diesel with Indirect Fuel Injection, Non-Turbo and Aftermarket Turbo, with DMF. Valeo type DMF not included. With stripped chassis.	07076
7.3	445	V8	1992	1992	Diesel with Indirect Fuel Injection, Non-Turbo and Aftermarket Turbo, with DMF. Valeo type DMF included.	07076A
7.3	445	V8	1992	1992	Diesel with Indirect Fuel Injection, Non-Turbo and Aftermarket Turbo, with DMF. Valeo type DMF not included.	07076
7.3	445	V8	1992	1992	Diesel with Indirect Fuel Injection, Non-Turbo and Factory Turbo, 8th Digit of VIN K. LUK type solid flywheel replacement kit contains solid flywheel and mounting bolts. Must be used as matched set.	07131B
7.3	445	V8	1992	1992	Diesel,With Indirect Fuel Injection,8th Digit of VIN# M, Non-Turbo and Aftermarket Turbo, LUK type solid flywheel replacement, kit contains flywheel.	07131A
7.3	445	V8	1992	1992	Diesel,With Indirect Fuel Injection,8th Digit of VIN# M, Non-Turbo and Aftermarket Turbo, LUK type solid flywheel replacement, kit does not contain flywheel.	07131
7.3	445	V8	1993	1993	Diesel with Indirect Fuel Injection, Factory Turbo, 8th Digit of VIN C. LUK type solid flywheel replacement kit contains solid flywheel and mounting bolts. Must be used as matched set.	07131A
7.3	445	V8	1993	1993	Diesel,With Indirect Fuel Injection, 8th Digit of VIN# C,Factory Turbo, LUK type solid flywheel replacement, kit contains flywheel.	07131B
7.3	445	V8	1993	1993	Diesel,With Indirect Fuel Injection, 8th Digit of VIN# C,Factory Turbo, LUK type solid flywheel replacement, kit does not contain flywheel.	07131
7.3	445	V8	1993	1993	Turbo Diesel, 5 Spd with Indirect Fuel Injection, VIN C. LUK Type Solid Flywheel and mounting bolts included.	KFM18A
7.3	445	V8	1993	1993	Turbo Diesel, 5 Spd with Indirect Fuel Injection, VIN C. LUK Type Solid Flywheel not Included. Use this kit when solid flywheel is present.	KFM18
7.3	445	V8	1993	1993	Turbo, 5 Spd with Indirect Fuel Injection, VIN C. Exedy/Daikin type includes solid FW.Must be sold as matched set..Economy version	FMK1007
7.3	445	V8	1993	1994	Diesel with Indirect Fuel Injection, Non-Turbo and Aftermarket Turbo, with DMF. Valeo type DMF included.	07076A
7.3	445	V8	1993	1994	Diesel with Indirect Fuel Injection, Non-Turbo and Aftermarket Turbo, with DMF. Valeo type DMF not included.	07076
7.3	445	V8	1993	1994	Diesel with Indirect Fuel Injection, Non-Turbo and Factory Turbo, 8th Digit of VIN K. LUK type solid flywheel replacement kit contains solid flywheel and mounting bolts. Must be used as matched set.	07131B
7.3	445	V8	1993	1994	Diesel, 5 Spd with Indirect Fuel Injection, VIN M. LUK Type Solid Flywheel not Included. Use this kit when solid flywheel is present.	KFM18
7.3	445	V8	1993	1994	Diesel, 5 Spd with Indirect Fuel Injection, VIN M. LUK Type Solid Flywheel and mounting bolts included.	KFM18A
7.3	445	V8	1993	1994	Diesel, 5 Spd with Indirect Fuel Injection. Valeo Type Solid Flywheel Replacement Kit Includes Flywheel and Mounting Bolts.	KFM15A
7.3	445	V8	1993	1994	Diesel,With Indirect Fuel Injection,8th Digit of VIN# M, Non-Turbo and Aftermarket Turbo, LUK type solid flywheel replacement, kit contains flywheel.	07131A
7.3	445	V8	1993	1994	Diesel,With Indirect Fuel Injection,8th Digit of VIN# M, Non-Turbo and Aftermarket Turbo, LUK type solid flywheel replacement, kit does not contain flywheel.	07131
7.3	445	V8	1993	1994	Turbo Diesel, 5 Spd with Indirect Fuel Injection, VIN K. LUK Type Solid Flywheel and mounting bolts included.	KFM18A
7.3	445	V8	1993	1994	Turbo Diesel, 5 Spd with Indirect Fuel Injection. Valeo Type Solid Flywheel Replacement Kit Includes Flywheel and Mounting Bolts.	KFM15A
7.3	445	V8	1994	1994	Diesel with Direct Fuel Injection, 8th digit of VIN # F, Non-Turbo and Factory Turbo, LUK type solid flywheel replacement, kit does not contain flywheel.	07131
7.3	445	V8	1994	1994	Diesel with Direct Fuel Injection, Factory Turbo, 8th Digit of VIN F. LUK type solid flywheel replacement kit contains solid flywheel and mounting bolts. Must be used as matched set.	07131A
7.3	445	V8	1994	1994	Diesel with Direct Fuel Injection, Non-Turbo and Aftermarket Turbo, with DMF. Valeo type DMF included.	07076A
7.3	445	V8	1994	1994	Diesel with Direct Fuel Injection, Non-Turbo and Aftermarket Turbo, with DMF. Valeo type DMF not included.	07076
7.3	445	V8	1994	1994	Diesel with Direct Fuel Injection, Non-Turbo and Factory Turbo, 8th Digit of VIN F. LUK type solid flywheel replacement kit contains solid flywheel and mounting bolts. Must be used as matched set.	07131B
7.3	445	V8	1994	1994	Diesel with Indirect Fuel Injection, Factory Turbo, 8th Digit of VIN K. LUK type solid flywheel replacement kit contains solid flywheel and mounting bolts. Must be used as matched set.	07131A
7.3	445	V8	1994	1994	Diesel,With Indirect Fuel Injection,8th Digit of VIN# K, Factory Turbo, LUK type solid flywheel replacement, kit contains flywheel.	07131B
7.3	445	V8	1994	1994	Diesel,With Indirect Fuel Injection,8th Digit of VIN# K, Factory Turbo, LUK type solid flywheel replacement, kit does not contain flywheel.	07131
7.3	445	V8	1994	1994	Turbo Diesel, 5 Spd with Indirect Fuel Injection, VIN K. LUK Type Solid Flywheel not Included. Use this kit when solid flywheel is present.	KFM18
7.3	445	V8	1994	1994	Turbo, 5 Spd with Indirect Fuel Injection, VIN K. Exedy/Daikin type includes solid FW.Must be sold as matched set..Economy version	FMK1007

2

EXEDY OEM	Disc (mm)	Disc (in)	Spline Dia	Splines	Master Cylinder	Slave Cylinder	Clutch Cable	Clutch Fork	New Flywheel
—	311	12-1/4	1-1/4	10	MC356	—	—	—	FWFMC127
—	311	12-1/4	1-1/4	10	MC356	—	—	—	FWFMC127
—	280	11	1-1/4	10	MC356	SC735	—	—	FWFTF01
—	280	11	1-1/4	10	MC361	—	—	—	FWFTF01
—	280	11	1-1/4	10	MC361	—	—	—	FWFTF01
—	311	12-1/4	1-1/4	10	MC361	—	—	—	FWFMC128
—	311	12-1/4	1-1/4	10	MC361	—	—	—	FWFMC127
—	311	12-1/4	1-1/4	10	MC361	—	—	—	FWFMC127
—	311	12-1/4	1-1/4	10	MC429	SC735	—	—	FWFMC127
—	311	12-1/4	1-1/4	10	MC429	SC735	—	—	FWFMC128
—	311	12-1/4	1-1/4	10	MC429	SC735	—	—	FWFMC127
—	330	13	1-1/4	10	MC429	SC735	—	—	FWFMC140
—	330	13	1-1/4	10	MC429	SC735	—	—	FWFMC140
—	330	13	1-1/4	10	MC429	SC735	—	—	FWFMC140
—	280	11	1-1/4	10	MC429	SC735	—	—	FWFTF01
—	280	11	1-1/4	10	MC429	SC735	—	—	FWFTF01
—	311	12-1/4	1-1/4	10	MC429	SC735	—	—	FWFMC128
—	330	13	1-1/4	10	MC429	SC735	—	—	FWFMC140
—	330	13	1-1/4	10	MC429	SC735	—	—	FWFMC140
—	330	13	1-1/4	10	MC429	SC735	—	—	FWFMC445
—	311	12-1/4	1-1/4	10	MC429	SC735	—	—	FWFMC127
—	311	12-1/4	1-1/4	10	MC429	SC735	—	—	FWFMC127
—	330	13	1-1/4	10	MC429	SC735	—	—	FWFMC140
—	330	13	1-1/4	10	MC429	SC735	—	—	FWFMC445
—	311	12-1/4	1-1/4	10	MC429	SC735	—	—	FWFMC127
—	311	12-1/4	1-1/4	10	MC429	SC735	—	—	FWFMC127
—	280	11	1-1/4	10	MC429	SC735	—	—	FWFTF01
—	280	11	1-1/4	10	MC429	SC735	—	—	FWFTF01
—	311	12-1/4	1-1/4	10	MC429	SC735	—	—	FWFMC128
—	311	12-1/4	1-1/4	10	MC429	SC735	—	—	FWFMC127
—	311	12-1/4	1-1/4	10	MC429	SC735	—	—	FWFMC128
—	311	12-1/4	1-1/4	10	MC429	SC735	—	—	FWFMC127
—	330	13	1-1/4	10	MC429	SC735	—	—	FWFMC140
—	330	13	1-1/4	10	MC429	SC735	—	—	FWFMC140

2

Liter	CC/IN	Cyl	Years		Application Information	Kit
			To	From		
FORD TRUCK, SUV & VAN continued						
<i>BRONCO, F100-550 continued</i>						
7.3	445	V8	1994	1997	Turbo Diesel, 5 Spd with Direct Fuel Injection, VIN F. LUK Type Solid Flywheel and mounting bolts included.	KFM18A
7.3	445	V8	1994	1997	Turbo Diesel, 5 Spd with Direct Fuel Injection, VIN F. LUK Type Solid Flywheel not Included. Use this kit when solid flywheel is present.	KFM18
7.3	445	V8	1994	1997	Turbo Diesel, 5 Spd with Direct Fuel Injection. Valeo Type Solid Flywheel Replacement Kit Includes Flywheel and Mounting Bolts.	KFM15A
7.3	445	V8	1994	1997	Turbo, 5 Spd with Direct Fuel Injection, VIN F. Exedy/Daikin type includes solid FW.Must be sold as matched set..Economy version	FMK1007
7.3	445	V8	1999	2003	Turbo Diesel, 6 Spd with direct fuel injection and LUK OE solid flywheel. LUK type solid flywheel is included. This kit must be installed as a matched set.	KFM16A
7.3	445	V8	1999	2003	Turbo Diesel, 6 Spd with direct fuel injection and Valeo OE solid flywheel. Valeo type solid flywheel included.	KFM17A
7.3	445	V8	1999	2003	Turbo Diesel, 6 Spd with direct fuel injection and Valeo OE solid flywheel. Valeo type solid flywheel not included.	KFM17
7.3	445	V8	1999	2003	Turbo Diesel,6 Spd with direct fuel injection. Exedy/Daikin version includes solid FW. This kit must be installed as a matched set.Economy Version	FMK1008
7.3	445	V8	1999	2003	Turbo Diesel,6 Spd with direct fuel injection. Exedy/Daikin version includes solid FW. This kit must be installed as a matched set, HD Version contains Cushion Button disc suited for 680 ft. lbs./Torque at the wheel	FMK1008HD
7.5	458	V8	1973	1979	—	07050
7.5	458	V8	1983	1983	4 Spd with 11" Disc	07022
7.5	458	V8	1983	1983	4 Spd with 12" Disc	07065
7.5	458	V8	1984	1986	4 Spd with 11" Disc	07022
7.5	458	V8	1984	1986	4 Spd with 12" Disc	07065
7.5	458	V8	1984	1987	4 Spd with 11" Disc	07022
7.5	458	V8	1984	1987	4 Spd with 12" Disc	07065
7.5	458	V8	1987	1987	4 Spd with 11" Disc	07022
7.5	458	V8	1987	1987	4 Spd with 12" Disc	07065
7.5	458	V8	1988	1991	—	07035
7.5	458	V8	1992	1992	—	07035
7.5	458	V8	1993	1995	—	07092
7.5	458	V8	1996	1997	—	07092
COURIER						
1.8	110	L4	1972	1974	—	07021
<i>E100-350</i>						
2.8	171	L6	1968	1971	—	07014
3.9	238	L6	1967	1967	—	07014
3.9	238	L6	1968	1974	—	07027
4.9	299	L6	1972	1972	11" Disc	07027
4.9	299	L6	1973	1974	11" Disc	07027
4.9	299	L6	1975	1977	11" Disc	07027
4.9	299	L6	1978	1979	11" Disc	07015
4.9	299	L6	1980	1982	11" Disc	07015
4.9	299	L6	1981	1982	10" Disc	07014
4.9	299	L6	1983	1983	10" Disc	07016
4.9	299	L6	1983	1983	11" Disc	07013
4.9	299	L6	1984	1984	11" Disc	07032
4.9	299	L6	1984	1987	10" Disc	07016
4.9	299	L6	1985	1986	11" Disc	KFM04
4.9	299	L6	1986	1986	11" Disc	KFM04
4.9	299	L6	1986	1987	10" Disc	07016
4.9	299	L6	1988	1989	10" Disc	07056
4.9	299	L6	1988	1989	11" Disc	07057
5.0	302	V8	1968	1974	—	07027
5.0	302	V8	1975	1975	—	07027
5.0	302	V8	1979	1979	—	07015
5.0	302	V8	1980	1982	10" Disc	07014
5.0	302	V8	1980	1982	11" Disc	07015
5.0	302	V8	1983	1983	10" Disc	07016
5.0	302	V8	1983	1983	11" Disc	07013
5.0	302	V8	1984	1986	10" Disc	07016

2

EXEDY OEM	Disc (mm)	Disc (in)	Spline Dia	Splines	Master Cylinder	Slave Cylinder	Clutch Cable	Clutch Fork	New Flywheel
—	330	13	1-1/4	10	MC429	SC735	—	—	FWFMC140
—	330	13	1-1/4	10	MC429	SC735	—	—	FWFMC140
—	330	13	1-1/4	10	MC429	SC735	—	—	FWFMC445
—	330	13	1-1/4	10	MC429	SC735	—	—	FWFMC140
—	330	13	1-3/8	10	MC356	SC738	—	—	FWFMC140
—	330	13	1-3/8	10	MC356	SC738	—	—	FWFMC445
—	330	13	1-3/8	10	MC356	SC738	—	—	FWFMC445
—	330	13	1-3/8	10	MC356	SC738	—	—	FWFMC140M
—	330	13	1-3/8	10	MC356	SC738	—	—	FWFMC140M
—	302	11-7/8	1-1/16	10	—	—	—	—	—
—	280	11	1-1/16	10	MC357	SC729	—	—	—
—	302	11-7/8	1-1/16	10	MC357	SC729	—	—	FWFM109
—	280	11	1-1/16	10	MC442	SC886	—	—	—
—	302	11-7/8	1-1/16	10	MC442	SC886	—	—	FWFM109
—	280	11	1-1/16	10	—	—	—	—	—
—	302	11-7/8	1-1/16	10	—	—	—	—	FWFM109
—	280	11	1-1/16	10	MC443	SC886	—	—	—
—	302	11-7/8	1-1/16	10	MC443	SC886	—	—	FWFM109
—	305	12	1-1/4	10	MC355	SC729	—	—	FWFM110
—	305	12	1-1/4	10	MC429	SC729	—	—	FWFM110
—	311	12-1/4	1-1/4	10	MC429	SC735	—	—	—
—	311	12-1/4	1-1/4	10	MC361	SC737	—	—	—
Y	215	8-1/2	15/16	22	MC477	SC830	—	—	—
—	254	10	1-1/16	10	—	SC846	—	—	—
—	254	10	1-1/16	10	—	—	—	—	—
—	280	11	1-1/16	10	—	—	—	—	—
—	280	11	1-1/16	10	—	—	—	—	—
—	280	11	1-1/16	10	—	—	—	CF101	—
—	280	11	1-1/16	10	—	—	—	CF102	—
—	280	11	1-1/16	10	—	—	—	CF102	—
—	280	11	1-1/16	10	—	—	—	—	FWFM117
—	254	10	1-1/16	10	—	—	—	—	FWFM117
—	254	10	1-1/16	10	—	SC728	—	—	FWFM117
—	280	11	1-1/16	10	—	—	—	—	FWFM117
—	280	11	1-1/16	10	MC438	SC728	—	CF117	FWFM117
—	254	10	1-1/16	10	MC438	SC728	—	CF117	FWFM117
—	280	11	1-1/16	10	MC438	SC728	—	CF117	FWFM117
—	280	11	1-1/16	10	MC356	SC728	—	CF117	FWFM117
—	254	10	1-1/16	10	MC356	SC728	—	CF117	FWFM117
—	254	10	1-1/16	10	MC438	SC783	—	CF117	FWFM117
—	280	11	1-1/16	10	MC438	SC783	—	CF117	FWFM117
—	280	11	1-1/16	10	—	—	—	—	FWFM116
—	280	11	1-1/16	10	—	—	—	CF102	FWFM116
—	280	11	1-1/16	10	—	—	—	—	—
—	254	10	1-1/16	10	—	—	—	—	—
—	280	11	1-1/16	10	—	—	—	—	FWFM116
—	254	10	1-1/16	10	—	—	—	—	—
—	280	11	1-1/16	10	—	SC728	—	—	FWFM116
—	254	10	1-1/16	10	MC438	SC788	—	—	—

Liter	CC/IN	Cyl	Years		Application Information	Kit
			To	From		
FORD TRUCK, SUV & VAN continued						
<i>E100-350 continued</i>						
5.0	302	V8	1984	1986	11" Disc	07013
5.0	302	V8	1987	1987	—	07032
5.0	302	V8	1988	1989	—	07057
5.8	351	V8	1975	1977	—	07027
5.8	351	V8	1978	1978	—	07015
5.8	351	V8	1979	1979	—	07015
5.8	351	V8	1980	1982	—	07015
5.8	351	V8	1983	1983	—	07013
5.8	351	V8	1984	1986	10" Disc	07016
5.8	351	V8	1984	1986	11" Disc	07022
5.8	351	V8	1986	1986	10" Disc	07016
5.8	351	V8	1986	1986	11" Disc	07022
5.8	351	V8	1987	1987	—	KFM04
5.8	351	V8	1987	1987	—	KFM04
5.8	351	V8	1988	1989	—	07057
5.8	351	V8	1988	1989	—	07057
6.0	366	V8	2004	2007	Turbo Diesel, Suits Solid FW, Sold as Kit Only	FMK1016
6.8	415	V10	1999	2007	Sold as Kit Only	FMK1018
<i>ESCAPE</i>						
2.0	122	L4	2001	2004	—	KFM16
2.3	140	L4	2005	2008	Sold as Kit Only	FMK1019
<i>EXCURSION</i>						
6.0	366	V8	2004	2005	Turbo Diesel, Suits Solid FW, Sold as Kit Only	FMK1016
6.8	415	V10	2000	2005	Sold as Kit Only	FMK1018
<i>EXPLORER</i>						
4.0	244	V6	1991	1991	—	07077
4.0	244	V6	1992	1992	—	07077
4.0	244	V6	1993	1994	—	07096
4.0	244	V6	1995	1997	—	07096
4.0	244	V6	1998	1999	Self Adjusting Clutch	07139
4.0	244	V6	2000	2000	Self Adjusting Clutch	07139
4.0	244	V6	2001	2003	—	FMK1000
<i>P100-350</i>						
2.8	171	L6	1965	1967	—	07014
3.9	238	L6	1968	1972	—	07027
4.9	299	L6	1968	1972	—	07027
4.9	299	L6	1973	1977	—	07027
<i>RANGER</i>						
2.0	122	L4	1983	1984	—	07041
2.0	122	L4	1985	1987	—	07048
2.0	122	L4	1988	1988	—	07054
2.2	134	L4	1983	1984	Diesel	10008
2.3	140	L4	1983	1984	—	07041
2.3	140	L4	1985	1987	—	07048
2.3	140	L4	1985	1987	Turbo Diesel	07048
2.3	140	L4	1988	1991	Non Pre-Damped	07054
2.3	140	L4	1988	1991	Pre-Damped	07132
2.3	140	L4	1992	1992	Non Pre-Damped	07054
2.3	140	L4	1992	1992	Pre-Damped	07132
2.3	140	L4	1993	1994	—	07093
2.3	140	L4	1995	2008	Non-Self Adjusting Clutch, EXEDY Economy version	KFM07
2.3	140	L4	1995	2008	Self Adjusting Clutch	KFM30
2.5	153	L4	1998	2004	Non-Self Adjusting Clutch, EXEDY Economy version	KFM07
2.5	153	L4	1998	2004	Self Adjusting Clutch	KFM30
2.8	171	V6	1983	1983	—	07041
2.8	171	V6	1984	1984	—	07041
2.8	171	V6	1985	1985	—	07048

	EXEDY OEM	Disc (mm)	Disc (in)	Spline Dia	Splines	Master Cylinder	Slave Cylinder	Clutch Cable	Clutch Fork	New Flywheel
	—	280	11	1-1/16	10	MC438	SC728	—	—	FWFM116
	—	280	11	1-1/16	10	MC438	SC728	—	—	FWFM116
	—	280	11	1-1/16	10	MC438	SC783	—	—	—
	—	280	11	1-1/16	10	—	SC846	—	—	—
	—	280	11	1-1/16	10	—	—	—	—	FWFM116
	—	280	11	1-1/16	10	—	—	—	CF102	FWFM116
	—	280	11	1-1/16	10	—	—	—	CF107	FWFM116
	—	280	11	1-1/16	10	—	—	—	—	FWFM116
	—	254	10	1-1/16	10	MC438	SC728	—	—	—
	—	280	11	1-1/16	10	MC438	SC728	—	—	FWFM116
	—	254	10	1-1/16	10	MC356	SC728	—	—	—
	—	280	11	1-1/16	10	MC356	SC728	—	—	FWFM116
	—	280	11	1-1/16	10	MC356	SC728	—	—	FWFM116
	—	280	11	1-1/16	10	MC438	SC728	—	—	FWFM116
	—	280	11	1-1/16	10	—	SC728	—	—	—
	—	280	11	1-1/16	10	MC438	SC728	—	—	—
	—	330	13	1-3/8	10	—	—	—	—	FWFMF08
	—	305	11-15/16	1-1/4	10	—	SC739	—	—	—
	—	225	8-7/8	15/16	22	MC370	SC740	—	—	—
	—	240	9-7/16	1	23	—	—	—	—	—
	—	330	13	1-3/8	10	—	—	—	—	FWFMF08
	—	305	11-15/16	1-1/4	10	—	SC739	—	—	—
	—	254	10	1-1/16	23	MC353	SC783	—	—	FMF505
	—	254	10	1-1/16	23	MC359	SC783	—	—	FMF505
	—	254	10	1-1/16	23	MC364	SC778	—	—	FMF505
	—	254	10	1-1/16	23	MC367	SC778	—	—	FMF505
	—	257	10-1/8	1-1/16	23	MC367	SC778	—	—	FMF509
	—	257	10-1/8	1-1/16	23	MC367	SC778	—	—	FMF509
	—	257	10-1/8	1	23	MC367	SC778	—	—	FMF509
	—	254	10	1-1/16	10	—	SC846	—	—	—
	—	280	11	1-1/16	10	—	SC846	—	—	—
	—	280	11	1-1/16	10	—	—	—	—	—
	—	280	11	1-1/16	10	—	—	—	CF101	—
	—	225	8-7/8	1	23	MC352	SC729	—	—	—
	Y	225	8-7/8	1	23	MC352	SC732	—	—	—
	Y	225	8-7/8	1	23	MC353	SC783	—	—	—
	Y	225	8-7/8	15/16	22	MC352	SC730	—	—	—
	—	225	8-7/8	1	23	MC352	SC700	—	—	FWFM122
	Y	225	8-7/8	1	23	MC352	SC732	—	—	FWFM122
	Y	225	8-7/8	1	23	MC352	SC732	—	—	FWFM122
	Y	225	8-7/8	1	23	MC353	SC783	—	—	FWFM122
	—	225	8-7/8	1	23	MC353	SC783	—	—	FWFM122
	Y	225	8-7/8	1	23	MC358	SC783	—	—	FWFM122
	—	225	8-7/8	1	23	MC358	SC783	—	—	FWFM122
	Y	225	8-7/8	1	23	MC365	SC778	—	—	—
	—	225	8-7/8	1	23	MC367	SC778	—	—	—
	—	225	8-7/8	1	23	MC367	SC778	—	—	—
	—	225	8-7/8	1	23	MC367	SC778	—	—	—
	—	225	8-7/8	1	23	MC367	SC778	—	—	—
	—	225	8-7/8	1	23	MC367	SC778	—	—	—
	—	225	8-7/8	1	23	MC352	SC700	—	—	FWFM122
	—	225	8-7/8	1	23	MC352	SC732	—	—	—
	Y	225	8-7/8	1	23	MC352	SC732	—	—	—

Liter	CC/IN	Cyl	Years		Application Information	Kit
			To	From		
FORD TRUCK, SUV & VAN continued						
<i>RANGER continued</i>						
2.9	177	V6	1986	1987	—	07048
2.9	177	V6	1988	1991	—	07054
2.9	177	V6	1992	1992	—	07054
3.0	183	V6	1991	1991	—	07054
3.0	183	V6	1992	1992	—	07054
3.0	183	V6	1993	1994	To Oct 31/1994	07099
3.0	183	V6	1995	2007	Non-Self Adjusting Clutch, EXEDY Economy version	KFM06
3.0	183	V6	1995	2007	Self Adjusting Clutch	KFM30
4.0	244	V6	1990	1991	—	07077
4.0	244	V6	1992	1992	—	07077
4.0	244	V6	1993	1994	—	07096
4.0	244	V6	1995	1997	—	07096
4.0	244	V6	1998	2000	Self Adjusting Clutch	07139
4.0	244	V6	2001	2008	Self Adjusting Clutch	FMK1000
GEO (Performance Applications Available)						
<i>METRO</i>						
1.0	61	L3	1989	1997	—	04124
1.3	79	L4	1995	1997	—	04100
<i>PRIZM</i>						
1.6	98	L4	1989	1989	DOHC	16074
1.6	98	L4	1989	1989	SOHC	16070
1.6	98	L4	1990	1990	DOHC	16074
1.6	98	L4	1990	1991	SOHC, To 4/30/91	16070
1.6	98	L4	1991	1991	8th Digit of VIN # is 5, from 5/1/91	KTY03
1.6	98	L4	1991	1992	8th Digit of VIN # is 6, from 5/1/91	04152
1.6	98	L4	1991	1992	SOHC, From 5/1/91	KTY06
1.6	98	L4	1992	1992	8th Digit of VIN # is 5, from 5/1/91	16074
1.6	98	L4	1993	1997	—	KTY03
1.8	110	L4	1993	1997	—	KTY03
<i>SPECTRUM</i>						
1.5	92	L4	1989	1989	Non-Turbo	04063
1.5	92	L4	1989	1989	Turbo	04099
<i>STORM</i>						
1.6	98	L4	1990	1993	—	04112
1.8	110	L4	1992	1993	—	09017
GEO SUV						
<i>TRACKER</i>						
1.6	98	L4	1989	1998	—	04137
GMC LIGHT TRUCK, SUV & VAN						
<i>CABALLERO, SPRINT</i>						
3.3	201	V6	1979	1979	—	04021
3.8	232	V6	1980	1981	—	04021
5.0	305	V8	1979	1981	—	04021
5.7	348	V8	1971	1975	—	04021
5.7	348	V8	1978	1978	—	04021
6.6	403	V8	1971	1972	—	04049
7.4	452	V8	1971	1973	12" Diaph Clutch	04064
7.4	452	V8	1971	1973	12" Diaph Type Clutch with Ceramic Button	04105
7.4	452	V8	1971	1975	11" Disc	04020
7.4	452	V8	1974	1974	12" Diaph Clutch	04064
7.4	452	V8	1974	1974	12" Diaph Type Clutch with Ceramic Button	04105
7.4	452	V8	1975	1975	12" Diaph Clutch	04064
7.4	452	V8	1975	1975	12" Diaph Type Clutch with Ceramic Button	04105

2

EXEDY OEM	Disc (mm)	Disc (in)	Spline Dia	Splines	Master Cylinder	Slave Cylinder	Clutch Cable	Clutch Fork	New Flywheel
Y	225	8-7/8	1	23	MC352	SC732	—	—	—
Y	225	8-7/8	1	23	MC353	SC783	—	—	—
Y	225	8-7/8	1	23	MC358	SC783	—	—	—
Y	225	8-7/8	1	23	MC353	SC783	—	—	FMF508
Y	225	8-7/8	1	23	MC359	SC783	—	—	FMF508
—	225	8-7/8	1	23	MC364	SC738	—	—	FMF508
—	228	9	1	23	MC367	SC778	—	—	FMF507
—	228	9	1	23	MC367	SC778	—	—	FMF507
—	254	10	1-1/16	23	MC353	SC778	—	—	FMF505
—	254	10	1-1/16	23	MC359	SC778	—	—	FMF505
—	254	10	1-1/16	23	MC364	SC778	—	—	FMF505
—	254	10	1-1/16	23	MC367	SC778	—	—	FMF505
—	257	10-1/8	1-1/16	23	MC367	SC778	—	—	—
—	257	10-1/8	1	23	MC367	SC778	—	—	FMF509
Y	170	6-11/16	3/4	18	—	—	—	—	—
Y	190	7-1/2	3/4	18	—	—	—	—	—
—	210	8-1/4	1	21	MC251	SC818	—	—	TYF508
—	200	7-7/8	15/16	21	MC251	SC818	—	—	TYF508
—	210	8-1/4	1	21	MC265	SC660	—	—	TYF508
—	200	7-7/8	15/16	21	MC251	SC660	—	—	TYF508
—	210	8-1/4	1	21	MC265	SC660	—	—	TYF508
—	200	7-7/8	15/16	21	MC265	SC660	—	—	TYF508
—	200	7-7/8	15/16	21	MC265	SC660	—	—	TYF508
—	210	8-1/4	1	21	MC265	SC660	—	—	TYF508
—	210	8-1/4	1	21	MC265	SC818	—	—	TYF503
—	210	8-1/4	1	21	MC265	SC818	—	—	—
Y	184	7-1/4	1	14	—	—	—	—	—
Y	215	8-1/2	1	14	—	—	—	—	—
Y	200	7-7/8	15/16	14	—	—	—	—	—
Y	215	8-1/2	1	14	—	—	—	—	—
Y	215	8-7/16	7/8	20	—	—	CC809	—	—
—	265	10-1/2	1-1/8	10	—	—	—	—	—
—	265	10-1/2	1-1/8	10	—	—	—	—	—
—	265	10-1/2	1-1/8	10	—	—	—	—	FWGM101
—	265	10-1/2	1-1/8	10	—	—	—	—	—
—	265	10-1/2	1-1/8	10	—	—	—	—	FWGM101
—	280	11	1-1/8	10	—	—	—	—	FWGM100
—	300	11-3/4	1-1/8	10	—	—	—	—	—
—	300	11-3/4	1-1/8	10	—	—	—	—	—
—	280	11	1-1/8	26	—	—	—	—	—
—	300	11-3/4	1-1/8	10	—	—	—	—	FWGM102
—	300	11-3/4	1-1/8	10	—	—	—	—	FWGM102
—	300	11-3/4	1-1/8	10	—	—	—	—	—
—	300	11-3/4	1-1/8	10	—	—	—	—	—

2

Liter	CC/IN	Cyl	Years		Application Information	Kit
			To	From		
GMC LIGHT TRUCK, SUV & VAN continued						
<i>CANYON</i>						
2.8	171	L4	2004	2006	—	GMK1015
3.5	214	L5	2004	2006	Sold as Kit Only	GMK1028
<i>G1500-3500 VAN</i>						
3.2	195	L6	1966	1966	11" Disc	04072
3.8	232	L6	1964	1969	11" Disc	04072
4.1	250	L6	1967	1976	11" Disc	04072
4.1	250	L6	1977	1984	11" Disc	04049
4.1	250	L6	1977	1984	12" Diaph Clutch	04064
4.1	250	L6	1977	1984	12" Diaph Type Clutch with Ceramic Button	04105
4.3	262	V6	1985	1986	—	04089
4.3	262	V6	1987	1987	—	04089
4.6	281	V8	1967	1967	11" Disc	04072
4.8	293	L6	1974	1974	11" Disc	04049
4.8	293	L6	1974	1978	12" Diaph Clutch	04064
4.8	293	L6	1975	1978	11" Disc	04049
5.0	305	V8	1968	1973	—	04049
5.0	305	V8	1977	1984	11" Disc	04049
5.0	305	V8	1977	1984	12" Diaph Clutch	04064
5.0	305	V8	1985	1986	—	04121
5.0	305	V8	1987	1987	—	04121
5.0	305	V8	1988	1990	—	04121
5.7	348	V8	1970	1984	11" Disc	04049
5.7	348	V8	1970	1984	12" Diaph Clutch	04064
5.7	348	V8	1970	1984	12" Diaph Type Clutch with Ceramic Button	04105
5.7	348	V8	1985	1985	12" Diaph Clutch, Non-Pre Damped	04064
5.7	348	V8	1985	1985	Pre-Damped	04128
5.7	348	V8	1986	1987	12" Diaph Clutch, Non-Pre Damped	04064
5.7	348	V8	1986	1987	Pre-Damped	04128
5.7	348	V8	1988	1990	12" Diaph Clutch, Non-Pre Damped	04064
5.7	348	V8	1988	1990	Pre-Damped	04128
6.2	378	V8	1983	1984	Diesel, Non Pre-Damped	04087
6.2	378	V8	1983	1984	Diesel, Pre-Damped	04128
6.2	378	V8	1985	1986	Diesel, Non Pre-Damped	04087
6.2	378	V8	1985	1986	Diesel, Pre-Damped	04128
6.2	378	V8	1987	1987	Diesel, Non Pre-Damped	04087
6.2	378	V8	1987	1987	Diesel, Pre-Damped	04128
6.2	378	V8	1988	1990	Diesel, Non Pre-Damped	04087
6.2	378	V8	1988	1990	Diesel, Pre-Damped	04128
6.6	403	V8	1978	1980	—	04020
7.4	452	V8	1975	1976	12" Diaph Clutch, Non-Pre Damped	04064
7.4	452	V8	1975	1976	Pre-Damped	04122
7.4	452	V8	1988	1990	12" Diaph Clutch, Non-Pre Damped	04064
7.4	452	V8	1988	1990	Pre-Damped	04122
<i>JIMMY (FULL SIZE), C1500-3500, K1500-3500, R1500-3500, V1500-3500</i>						
3.8	232	L6	1966	1969	11" Disc	04072
4.1	250	L6	1966	1976	11" Disc	04072
4.1	250	L6	1977	1984	11" Disc	04049
4.1	250	L6	1977	1984	12" Diaph Clutch	04064
4.1	250	L6	1977	1984	12" Diaph Clutch with Ceramic Button	04105
4.3	262	V6	1986	1986	—	04089
4.3	262	V6	1987	1987	R & V Series	04089
4.3	262	V6	1988	1991	To 1/31/91	04089
4.3	262	V6	1991	1991	From 2/1/91	04121
4.3	262	V6	1992	1994	—	04121
4.3	262	V6	1995	1995	—	04121
4.3	262	V6	1996	1998	—	KGM10
4.3	262	V6	1999	2000	—	KGM17

EXEDY OEM	Disc (mm)	Disc (in)	Spline Dia	Splines	Master Cylinder	Slave Cylinder	Clutch Cable	Clutch Fork	New Flywheel
—	263	10-3/8	1-1/8	26	MC462	SC809	—	—	—
—	265	10-7/16	1-3/16	26	MC462	SC809	—	—	—
—	280	11	1-1/8	10	—	—	—	—	—
—	280	11	1-1/8	10	—	—	—	—	—
—	280	11	1-1/8	10	—	—	—	—	—
—	280	11	1-1/8	10	—	—	—	—	—
—	300	11-3/4	1-1/8	10	—	—	—	—	—
—	300	11-3/4	1-1/8	10	—	—	—	—	—
—	280	11	1-1/8	10	MC309	SC827	—	—	—
—	280	11	1-1/8	10	—	—	—	—	—
—	280	11	1-1/8	10	—	—	—	—	—
—	280	11	1-1/8	10	—	—	—	—	—
—	300	11-3/4	1-1/8	10	—	—	—	—	—
—	280	11	1-1/8	10	—	—	—	—	FWGM104
—	280	11	1-1/8	10	—	—	—	—	—
—	280	11	1-1/8	10	—	—	—	—	—
—	300	11-3/4	1-1/8	10	—	—	—	—	—
—	280	11	1-1/8	10	MC309	SC827	—	—	—
—	280	11	1-1/8	10	—	—	—	—	—
—	280	11	1-1/8	10	—	SC708	—	—	—
—	280	11	1-1/8	10	—	—	—	—	—
—	300	11-3/4	1-1/8	10	—	—	—	—	—
—	300	11-3/4	1-1/8	10	—	—	—	—	—
—	300	11-3/4	1-1/8	10	MC309	SC827	—	—	—
—	300	11-3/4	1-1/8	10	MC309	SC827	—	—	—
—	300	11-3/4	1-1/8	10	MC309	SC827	—	—	FWGM103
—	300	11-3/4	1-1/8	10	MC309	SC827	—	—	FWGM103
—	300	11-3/4	1-1/8	10	—	SC708	—	—	—
—	300	11-3/4	1-1/8	10	—	SC708	—	—	—
—	302	11-7/8	1-1/8	10	—	—	—	—	—
—	300	11-3/4	1-1/8	10	—	—	—	—	—
—	302	11-7/8	1-1/8	10	MC309	SC827	—	—	—
—	300	11-3/4	1-1/8	10	MC309	SC827	—	—	—
—	302	11-7/8	1-1/8	10	—	—	—	—	—
—	300	11-3/4	1-1/8	10	—	—	—	—	—
—	302	11-7/8	1-1/8	10	—	SC708	—	—	—
—	300	11-3/4	1-1/8	10	—	SC708	—	—	—
—	280	11	1-1/8	26	—	—	—	—	FWGM100
—	300	11-3/4	1-1/8	10	—	—	—	—	FWGM102
—	302	11-7/8	1-1/8	10	—	—	—	—	FWGM102
—	300	11-3/4	1-1/8	10	—	SC708	—	—	FWGM102
—	302	11-7/8	1-1/8	10	—	SC708	—	—	FWGM102
—	280	11	1-1/8	10	—	—	—	—	—
—	280	11	1-1/8	10	—	—	—	—	—
—	280	11	1-1/8	10	—	—	—	—	—
—	300	11-3/4	1-1/8	10	—	—	—	—	—
—	300	11-3/4	1-1/8	10	—	—	—	—	—
—	280	11	1-1/8	10	MC309	SC827	—	—	FWGM108(1986)
—	280	11	1-1/8	10	MC309	SC827	—	—	—
—	280	11	1-1/8	10	MC310	SC708	—	—	FWGM108
—	280	11	1-1/8	10	MC310	SC706	—	—	FWGM108
—	280	11	1-1/8	10	MC372	SC741	—	—	FWGM108
—	280	11	1-1/8	10	MC380	SC741	—	—	FWGM108
—	280	11	1-1/8	10	MC377	SC746	—	—	FWGM108(1986)
—	280	11	1-1/8	10	MC381	SC746	—	—	—

Liter	CC/IN	Cyl	Years		Application Information	Kit
			To	From		
GMC LIGHT TRUCK, SUV & VAN continued						
<i>JIMMY (FULL SIZE), C1500-3500, K1500-3500, R1500-3500, V1500-3500 continued</i>						
4.3	262	V6	2001	2005	Slave Cylinder fits 5spd only	KGM21
4.6	281	V8	1967	1967	11" Disc	04072
4.6	281	V8	1967	1967	12" Diaph Clutch	04064
4.6	281	V8	1967	1967	12" Diaph Clutch with Ceramic Button	04105
4.8	293	L6	1966	1968	11" Disc	04072
4.8	293	L6	1969	1974	11" Disc	04049
4.8	293	L6	1975	1984	11" Disc	04049
4.8	293	L6	1985	1986	—	04081
4.8	293	L6	1987	1988	R&V Series	04081
4.8	293	V8	1999	2000	—	04181
4.8	293	V8	2001	2003	—	KGM44
4.8	293	V8	2004	2004	—	KGM44
4.8	293	V8	2005	2006	Sold as Kit Only	GMK1020
5.0	305	V6	1966	1967	12" Diaph Clutch	04064
5.0	305	V6	1966	1967	12" Diaph Clutch with Ceramic Button	04105
5.0	305	V8	1968	1968	—	04049
5.0	305	V8	1968	1970	12" Lever Clutch	04049
5.0	305	V8	1976	1984	11" Disc	04049
5.0	305	V8	1976	1984	12" Diaph Clutch	04064
5.0	305	V8	1976	1984	12" Diaph Clutch with Ceramic Button	04105
5.0	305	V8	1985	1987	—	04081
5.0	305	V8	1987	1987	R&V Series	04081
5.0	305	V8	1988	1991	—	04081
5.0	305	V8	1992	1994	—	04121
5.0	305	V8	1995	1995	—	04121
5.0	305	V8	1996	1998	—	04160
5.4	330	V8	1967	1968	12" Diaph Clutch	04064
5.4	330	V8	1967	1968	12" Diaph Clutch with Ceramic Button	04105
5.7	348	V8	1969	1984	12" Diaph Clutch	04064
5.7	348	V8	1969	1984	12" Diaph Clutch with Ceramic Button	04105
5.7	348	V8	1969	1986	11" Clutch	04049
5.7	348	V8	1974	1974	12" Diaph Clutch	04064
5.7	348	V8	1974	1974	12" Diaph Clutch with Ceramic Button	04105
5.7	348	V8	1978	1981	Diesel, 11" Clutch	04049
5.7	348	V8	1978	1981	Diesel, 12" Diaph Clutch	04064
5.7	348	V8	1978	1981	Diesel, 12" Diaph Clutch with Ceramic Button	04105
5.7	348	V8	1985	1987	12" Diaph Clutch	04064
5.7	348	V8	1985	1987	12" Diaph Clutch with Ceramic Button	04105
5.7	348	V8	1985	1990	11" Clutch	04049
5.7	348	V8	1988	1990	11" Clutch	04049
5.7	348	V8	1988	1990	12" Diaph Clutch	04064
5.7	348	V8	1988	1990	12" Diaph Clutch with Ceramic Button	04105
5.7	348	V8	1988	1990	R&V Series 12" Diaph Clutch with Ceramic Button	04105
5.7	348	V8	1988	1990	R&V Series with 12" Diaph Clutch	04064
5.7	348	V8	1991	1991	11" Disc To 1/31/91	04049
5.7	348	V8	1991	1991	12" Diaph Clutch with Ceramic Button, To 1/31/91	04105
5.7	348	V8	1991	1991	12" Diaph Clutch, To 1/31/91	04064
5.7	348	V8	1991	1991	Non Pre-Damped From 2/1/91	04122
5.7	348	V8	1991	1991	Pre-Damped From 2/1/91	04128
5.7	348	V8	1991	1991	R&V Series 12" Diaph Clutch, To 1/31/91	04064
5.7	348	V8	1991	1991	R&V Series with Pre-Damped From 2/1/91	04128
5.7	348	V8	1991	1991	R&V Series with 12" Diaph Clutch with Ceramic Button, To 1/31/91	04105
5.7	348	V8	1991	1991	R&V Series with Non Pre-Damped From 2/1/91	04122
5.7	348	V8	1992	1995	Non Pre-Damped	04122
5.7	348	V8	1992	1995	Pre-Damped	04128
5.7	348	V8	1996	2000	—	04170
6.0	366	V8	1999	2000	—	04171

2

EXEDY OEM	Disc (mm)	Disc (in)	Spline Dia	Splines	Master Cylinder	Slave Cylinder	Clutch Cable	Clutch Fork	New Flywheel
—	280	11	1-1/8	10	MC381	SC799	—	—	—
—	280	11	1-1/8	10	—	—	—	—	—
—	300	11-3/4	1-1/8	10	—	—	—	—	—
—	300	11-3/4	1-1/8	10	—	—	—	—	—
—	280	11	1-1/8	10	—	—	—	—	—
—	280	11	1-1/8	10	—	—	—	—	—
—	280	11	1-1/8	10	—	—	—	—	FWGM104
—	280	11	1-1/8	10	MC309	SC827	—	CF116	FWGM104
—	280	11	1-1/8	10	MC309	SC827	—	CF116	FWGM104
—	302	11-7/8	1-1/8	10	MC381	SC746	—	CF116	—
—	302	11-7/8	1-1/8	10	MC381	SC799	—	—	—
—	302	11-7/8	1-1/8	10	MC381	SC937	—	—	—
—	302	11-7/8	1-1/8	10	MC456	SC937	—	—	—
—	300	11-3/4	1-1/8	10	—	—	—	—	—
—	300	11-3/4	1-1/8	10	—	—	—	—	—
—	280	11	1-1/8	10	—	—	—	—	—
—	280	11	1-1/8	10	—	—	—	—	—
—	280	11	1-1/8	10	—	—	—	—	—
—	300	11-3/4	1-1/8	10	—	—	—	—	—
—	300	11-3/4	1-1/8	10	—	—	—	—	—
—	280	11	1-1/8	10	—	—	—	—	—
—	280	11	1-1/8	10	MC309	SC827	—	—	—
—	280	11	1-1/8	10	MC309	SC827	—	—	—
—	280	11	1-1/8	10	MC310	SC708	—	—	—
—	280	11	1-1/8	10	MC372	SC741	—	—	—
—	280	11	1-1/8	10	MC387	SC741	—	—	—
—	302	11-7/8	1-1/8	10	MC377	SC746	—	—	—
—	300	11-3/4	1-1/8	10	—	—	—	—	—
—	300	11-3/4	1-1/8	10	—	—	—	—	—
—	300	11-3/4	1-1/8	10	—	—	—	—	—
—	300	11-3/4	1-1/8	10	—	—	—	—	—
—	280	11	1-1/8	10	—	—	—	—	—
—	300	11-3/4	1-1/8	10	—	—	—	—	FWGM103
—	300	11-3/4	1-1/8	10	—	—	—	—	FWGM103
—	280	11	1-1/8	10	—	—	—	—	—
—	300	11-3/4	1-1/8	10	—	—	—	—	—
—	300	11-3/4	1-1/8	10	—	—	—	—	—
—	300	11-3/4	1-1/8	10	MC309	SC827	—	—	—
—	300	11-3/4	1-1/8	10	MC309	SC827	—	—	—
—	280	11	1-1/8	10	MC309	SC827	—	—	—
—	280	11	1-1/8	10	—	—	—	—	—
—	300	11-3/4	1-1/8	10	MC310	SC708	—	—	—
—	300	11-3/4	1-1/8	10	MC310	SC708	—	—	—
—	300	11-3/4	1-1/8	10	MC309	SC827	—	—	—
—	300	11-3/4	1-1/8	10	MC309	SC827	—	—	—
—	280	11	1-1/8	10	MC309	SC827	—	—	—
—	300	11-3/4	1-1/8	10	MC310	SC708	—	—	—
—	300	11-3/4	1-1/8	10	MC310	SC708	—	—	—
—	302	11-7/8	1-1/8	10	MC310	SC708	—	—	—
—	300	11-3/4	1-1/8	10	MC310	SC708	—	—	—
—	300	11-3/4	1-1/8	10	MC309	SC827	—	—	—
—	300	11-3/4	1-1/8	10	MC309	SC827	—	—	—
—	300	11-3/4	1-1/8	10	MC309	SC827	—	—	—
—	302	11-7/8	1-1/8	10	MC309	SC827	—	—	—
—	302	11-7/8	1-1/8	10	MC372	SC741	—	—	—
—	300	11-3/4	1-1/8	10	MC372	SC741	—	—	—
—	305	12	1-1/8	10	MC377	SC746	—	—	—
—	290	11-1/2	1-1/8	10	MC381	SC746	—	—	—

Liter	CC/IN	Cyl	Years		Application Information	Kit
			To	From		
GMC LIGHT TRUCK, SUV & VAN continued						
<i>JIMMY (FULL SIZE), C1500-3500, K1500-3500, R1500-3500, V1500-3500 continued</i>						
6.0	366	V8	2001	2003	—	GMK1009
6.0	366	V8	2004	2004	—	GMK1009
6.2	378	V8	1982	1984	Diesel	04087
6.2	378	V8	1985	1986	Diesel	04087
6.2	378	V8	1987	1989	Diesel	04087
6.2	378	V8	1990	1991	Diesel	04122
6.2	378	V8	1991	1991	R&V Series, Diesel	04122
6.2	378	V8	1992	1993	Diesel	04122
6.5	397	V8	1968	1969	—	04049
6.5	397	V8	1992	1994	Turbo Diesel for DMF, Not included	04131
6.5	397	V8	1992	1994	Turbo, Diesel with Solid Flywheel Option. Kit does not include flywheel.	04163
6.5	397	V8	1992	1994	Turbo Diesel with Solid Flywheel Option. Kit includes flywheel.	04163A
6.5	397	V8	1995	1995	Turbo Diesel for DMF, Not included	04131
6.5	397	V8	1995	1995	Turbo, Diesel with Solid Flywheel Option. Kit does not include flywheel.	04163
6.5	397	V8	1995	1995	Turbo Diesel with Solid Flywheel Option. Kit includes flywheel.	04163A
6.5	397	V8	1996	2002	Turbo Diesel 5 Spd with LUK Solid Type FW. Kit does not include flywheel.	04154
6.5	397	V8	1996	2002	Turbo Diesel 5 Spd with LUK Solid Type FW. Kit includes flywheel.	04154A
6.5	397	V8	1996	2002	Turbo Diesel 5 Spd with Valeo type DMF. Kit does not include flywheel.	KGM12
6.5	397	V8	1996	2002	Turbo Diesel 5 Spd with Valeo type DMF. Kit includes flywheel.	KGM12A
6.6	403	V8	1970	1972	12" Diaph Clutch	04064
6.6	403	V8	1970	1972	12" Diaph Type Clutch with Ceramic Button	04105
6.6	403	V8	1978	1980	—	04020
6.6	403	V8	2001	2003	Diesel 6 Spd, with DMF, Kit does not include flywheel, Does not include Release Bearing	KGM13
6.6	403	V8	2001	2003	Diesel 6 Spd, with DMF, Kit includes flywheel, Does not include Release Bearing	KGM13A
6.6	403	V8	2004	2006	Diesel 6 Spd, with DMF, Kit does not include flywheel, Does not include Release Bearing	KGM13
6.6	403	V8	2004	2006	Diesel 6 Spd, with DMF, Kit includes flywheel, Does not include Release Bearing	KGM13A
6.6	403	V8	2006	2006	Turbo, Diesel, Includes CSC Hydraulic Slave Cylinder, Sold as Kit Only, Fits Dual Mass FW	GMK1029
7.4	452	V8	1973	1973	12" Diaph Type Clutch with Ceramic Button	04105
7.4	452	V8	1973	1973	Diaph Type Clutch	04122
7.4	452	V8	1974	1984	12" Diaph Type Clutch with Ceramic Button	04105
7.4	452	V8	1974	1984	Diaph Type Clutch	04122
7.4	452	V8	1985	1986	12" Diaph Type Clutch with Ceramic Button	04105
7.4	452	V8	1985	1986	Diaph Type Clutch	04122
7.4	452	V8	1987	1991	R, V Series, Non Pre-Damped	04064
7.4	452	V8	1987	1991	R, V Series, Pre-Damped	04122
7.4	452	V8	1988	1991	12" Diaph Clutch, Non-Pre Damped	04064
7.4	452	V8	1988	1991	Pre-Damped	04122
7.4	452	V8	1992	1994	12" Diaph Clutch, Non-Pre Damped	04064
7.4	452	V8	1992	1994	Pre-Damped	04122
7.4	452	V8	1995	1995	12" Diaph Clutch, Non-Pre Damped	04064
7.4	452	V8	1995	1995	Pre-Damped	04122
7.4	452	V8	1996	2000	—	04154
7.4	452	V8	1996	2000	Turbo Diesel 5 Spd with LUK Solid Type FW. Kit includes flywheel.	04154A
8.1	494	V8	2001	2004	6 Spd, Sold as Kit Only, Includes Slave Cylinder	GMK1025
8.1	494	V8	2001	2002	5 Spd	KGM18
8.1	494	V8	2005	2006	From Jan 1/2004, Slave Cylinder Included, Sold as Kit Only	GMK1019
P1500-3500 STEPVAN						
3.8	232	L6	1966	1969	11" Disc	04072
4.1	250	L6	1966	1974	11" Disc	04072
4.3	262	V6	1990	1991	—	04089
4.3	262	V6	1992	1995	—	04121
4.3	262	V6	1996	1996	—	KGM10
4.3	262	V6	1999	1999	—	KGM17
4.6	281	V8	1967	1967	11" Disc	04072
4.8	293	L6	1966	1968	11" Disc	04072
4.8	293	L6	1969	1974	11" Disc	04049
4.8	293	L6	1975	1984	11" Disc	04049
4.8	293	L6	1985	1989	—	04081

2

EXEDY OEM	Disc (mm)	Disc (in)	Spline Dia	Splines	Master Cylinder	Slave Cylinder	Clutch Cable	Clutch Fork	New Flywheel
—	290	11-1/2	1-1/8	10	MC381	BRG0152	—	—	—
—	290	11-1/2	1-1/8	10	MC381	BRG0152	—	—	—
—	302	11-7/8	1-1/8	10	—	—	—	—	—
—	302	11-7/8	1-1/8	10	MC309	SC827	—	—	—
—	302	11-7/8	1-1/8	10	MC310	SC708	—	—	—
—	302	11-7/8	1-1/8	10	MC310	SC708	—	—	—
—	302	11-7/8	1-1/8	10	MC309	SC827	—	—	—
—	302	11-7/8	1-1/8	10	MC372	SC741	—	—	—
—	280	11	1-1/8	10	—	—	—	—	—
—	300	11-3/4	1-1/8	10	MC372	SC741	—	—	—
—	302	11-7/8	1-1/8	10	MC372	SC741	—	—	FWGMC126
—	302	11-7/8	1-1/8	10	MC372	SC741	—	—	FWGMC126
—	300	11-3/4	1-1/8	10	MC380	SC741	—	—	—
—	302	11-7/8	1-1/8	10	MC380	SC741	—	—	FWGMC126
—	302	11-7/8	1-1/8	10	MC380	SC741	—	—	FWGMC126
—	302	11-7/8	1-1/8	10	MC377	SC748	—	—	FWGMC126
—	302	11-7/8	1-1/8	10	MC377	SC748	—	—	FWGMC126
—	300	11-3/4	1-1/8	10	MC377	SC748	—	—	FWGMC01
—	300	11-3/4	1-1/8	10	MC377	SC748	—	—	FWGMC01
—	300	11-3/4	1-1/8	10	—	—	—	—	—
—	300	11-3/4	1-1/8	10	—	—	—	—	—
—	280	11	1-1/8	26	—	—	—	—	FWGM100
—	305	12	1-3/8	10	MC381	BRG0152	—	—	—
—	305	12	1-3/8	10	MC381	BRG0152	—	—	DMF029
—	305	12	1-3/8	10	MC381	BRG0152	—	—	—
—	305	12	1-3/8	10	MC381	BRG0152	—	—	DMF029
—	305	12	1-3/8	10	MC381	SC937	—	—	—
—	300	11-3/4	1-1/8	10	—	—	—	—	—
—	302	11-7/8	1-1/8	10	—	—	—	—	—
—	300	11-3/4	1-1/8	10	—	—	—	—	FWGM102
—	302	11-7/8	1-1/8	10	—	—	—	—	FWGM102
—	300	11-3/4	1-1/8	10	MC309	SC827	—	—	FWGM102
—	302	11-7/8	1-1/8	10	MC309	SC827	—	—	FWGM102
—	300	11-3/4	1-1/8	10	MC309	SC708	—	—	FWGM102
—	302	11-7/8	1-1/8	10	MC309	SC708	—	—	FWGM102
—	300	11-3/4	1-1/8	10	MC310	SC708	—	—	FWGM102
—	302	11-7/8	1-1/8	10	MC310	SC708	—	—	FWGM102
—	300	11-3/4	1-1/8	10	MC372	SC741	—	—	FWGM102
—	302	11-7/8	1-1/8	10	MC372	SC741	—	—	FWGM102
—	300	11-3/4	1-1/8	10	MC380	SC741	—	—	FWGM102
—	302	11-7/8	1-1/8	10	MC380	SC741	—	—	FWGM102
—	302	11-7/8	1-1/8	10	MC377	SC746	—	—	—
—	302	11-7/8	1-1/8	10	MC377	SC746	—	—	FWGMC126
—	295	11-11/16	1-3/8	10	MC377	BRG0152	—	—	—
—	300	11-3/4	1-1/4	10	MC377	SC801	—	—	—
—	295	11-11/16	1-3/8	10	MC377	BRG0152	—	—	—
—	280	11	1-1/8	10	—	—	—	—	—
—	280	11	1-1/8	10	—	—	—	—	—
—	280	11	1-1/8	10	MC375	SC744	—	—	FWGM108
—	280	11	1-1/8	10	MC374	SC741	—	—	FWGM108
—	280	11	1-1/8	10	MC379	SC748	—	—	FWGM108(1996)
—	280	11	1-1/8	10	—	—	—	—	—
—	280	11	1-1/8	10	—	—	—	—	—
—	280	11	1-1/8	10	—	—	—	—	—
—	280	11	1-1/8	10	—	—	—	—	FWGM104
—	280	11	1-1/8	10	—	—	—	—	FWGM104

Liter	CC/IN	Cyl	Years		Application Information	Kit
			To	From		
GMC LIGHT TRUCK, SUV & VAN continued						
<i>P1500-3500 STEPVAN continued</i>						
5.0	305	V8	1968	1969	—	04049
5.7	348	V8	1970	1978	11" Clutch	04049
5.7	348	V8	1970	1978	12" Diaph Clutch	04064
5.7	348	V8	1970	1988	12" Diaph Type Clutch with Ceramic Button	04105
5.7	348	V8	1979	1988	12" Diaph Clutch	04064
5.7	348	V8	1989	1991	12" Diaph Clutch	04064
5.7	348	V8	1989	1991	12" Diaph Type Clutch with Ceramic Button	04105
5.7	348	V8	1992	1995	Non Pre-Damped	04122
5.7	348	V8	1992	1995	Pre-Damped	04128
5.7	348	V8	1996	1996	—	04160
5.7	348	V8	1997	1999	—	04170
6.2	378	V8	1982	1984	Diesel Pre-Damped	04128
6.2	378	V8	1982	1984	Diesel, Non Pre-Damped	04087
6.2	378	V8	1985	1989	Diesel Pre-Damped	04128
6.2	378	V8	1985	1989	Diesel, Non Pre-Damped	04087
6.2	378	V8	1990	1991	Diesel Pre-Damped	04128
6.2	378	V8	1990	1991	Diesel, Non Pre-Damped	04087
6.2	378	V8	1992	1993	Diesel Pre-Damped	04128
6.2	378	V8	1992	1993	Diesel, Non Pre-Damped	04087
6.5	397	V8	1994	1994	Diesel Pre-Damped	04122
6.5	397	V8	1994	1994	Diesel, Non Pre-Damped	04146
6.5	397	V8	1995	1995	Diesel Pre-Damped	04122
6.5	397	V8	1995	1995	Diesel, Non Pre-Damped	04146
6.5	397	V8	1996	1999	Diesel 5 Spd with LUK Solid Type FW, Kit does not include flywheel.	04154
6.5	397	V8	1996	1999	Diesel, 5 Speed with LUK Solid Type FW. Kit includes flywheel.	04154A
6.5	397	V8	1996	1999	Turbo Diesel 5 Spd with Valeo type DMF. Kit does not include flywheel.	KGM12
6.5	397	V8	1996	1999	Turbo Diesel 5 Spd with Valeo type DMF. Kit includes flywheel.	KGM12A
6.5	397	V8	1997	1999	Turbo Diesel 5 Spd with LUK Solid Type FW. Kit does not include flywheel.	04154
6.5	397	V8	1997	1999	Turbo Diesel 5 Spd with LUK Solid Type FW. Kit includes flywheel.	04154A
7.4	452	V8	1970	1971	12" Diaph Clutch, Non-Pre Damped	04064
7.4	452	V8	1970	1971	Pre-Damped	04122
7.4	452	V8	1973	1973	12" Diaph Clutch, Non-Pre Damped	04064
7.4	452	V8	1973	1973	Pre-Damped	04122
7.4	452	V8	1974	1986	12" Diaph Clutch, Non-Pre Damped	04064
7.4	452	V8	1974	1986	Pre-Damped	04122
7.4	452	V8	1987	1987	12" Diaph Clutch, Non-Pre Damped	04064
7.4	452	V8	1987	1987	Pre-Damped	04122
7.4	452	V8	1988	1991	12" Diaph Clutch, Non-Pre Damped	04064
7.4	452	V8	1988	1991	Pre-Damped	04122
7.4	452	V8	1992	1994	12" Diaph Clutch, Non-Pre Damped	04064
7.4	452	V8	1992	1994	Pre-Damped	04122
7.4	452	V8	1995	1995	12" Diaph Clutch, Non-Pre Damped	04064
7.4	452	V8	1995	1995	Pre-Damped	04122
7.4	452	V8	1996	1999	—	04154
7.4	452	V8	1996	1999	Diesel 5 Spd with LUK Solid Type FW, Kit does not include flywheel.	04154
<i>S-15, JIMMY, SONOMA</i>						
2.0	122	L4	1983	1983	Non Pre-Damped	04065
2.0	122	L4	1983	1983	Pre-Damped	04130
2.0	122	L4	1984	1984	Non Pre-Damped	04065
2.0	122	L4	1984	1984	Pre-Damped	04130
2.2	134	L4	1994	1995	Non Pre-Damped	04138
2.2	134	L4	1996	2001	Non Pre-Damped	04155
2.5	153	L4	1985	1989	Non Pre-Damped	04065
2.5	153	L4	1985	1989	Pre-Damped	04130
2.5	153	L4	1990	1993	Non Pre-Damped	04065

EXEDY OEM	Disc (mm)	Disc (in)	Spline Dia	Splines	Master Cylinder	Slave Cylinder	Clutch Cable	Clutch Fork	New Flywheel
—	280	11	1-1/8	10	—	—	—	—	—
—	280	11	1-1/8	10	—	—	—	—	—
—	300	11-3/4	1-1/8	10	—	—	—	—	—
—	300	11-3/4	1-1/8	10	—	—	—	—	—
—	300	11-3/4	1-1/8	10	—	—	—	—	FWGM104
—	300	11-3/4	1-1/8	10	MC375	SC744	—	—	FWGM103
—	300	11-3/4	1-1/8	10	MC375	SC744	—	—	FWGM103
—	302	11-7/8	1-1/8	10	MC374	SC741	—	—	—
—	300	11-3/4	1-1/8	10	MC374	SC741	—	—	—
—	302	11-7/8	1-1/8	10	MC379	SC746	—	—	—
—	305	12	1-1/8	10	MC379	SC746	—	—	—
—	300	11-3/4	1-1/8	10	—	—	—	—	—
—	302	11-7/8	1-1/8	10	—	—	—	—	—
—	300	11-3/4	1-1/8	10	MC309	SC827	—	—	—
—	302	11-7/8	1-1/8	10	MC309	SC827	—	—	—
—	300	11-3/4	1-1/8	10	MC375	SC744	—	—	—
—	302	11-7/8	1-1/8	10	MC375	SC744	—	—	—
—	300	11-3/4	1-1/8	10	MC374	SC741	—	—	—
—	302	11-7/8	1-1/8	10	MC374	SC741	—	—	—
—	302	11-7/8	1-1/8	10	MC372	SC741	—	—	—
—	302	11-7/8	1-1/8	10	MC372	SC741	—	—	—
—	302	11-7/8	1-1/8	10	—	SC741	—	—	—
—	302	11-7/8	1-1/8	10	—	SC741	—	—	—
—	302	11-7/8	1-1/8	10	MC379	SC746	—	—	FWGMC126
—	302	11-7/8	1-1/8	10	MC379	SC746	—	—	FWGMC126
—	300	11-3/4	1-1/8	10	MC379	SC746	—	—	FWGMC01
—	300	11-3/4	1-1/8	10	MC379	SC746	—	—	FWGMC01
—	302	11-7/8	1-1/8	10	MC379	SC746	—	—	FWGMC126
—	302	11-7/8	1-1/8	10	MC379	SC746	—	—	FWGMC126
—	300	11-3/4	1-1/8	10	—	SC827	—	—	—
—	302	11-7/8	1-1/8	10	—	SC827	—	—	—
—	300	11-3/4	1-1/8	10	—	SC827	—	—	—
—	302	11-7/8	1-1/8	10	—	SC827	—	—	—
—	300	11-3/4	1-1/8	10	—	SC827	—	—	FWGM102
—	302	11-7/8	1-1/8	10	—	SC827	—	—	FWGM102
—	300	11-3/4	1-1/8	10	MC309	SC827	—	—	FWGM102
—	302	11-7/8	1-1/8	10	MC309	SC827	—	—	FWGM102
—	300	11-3/4	1-1/8	10	—	SC827	—	—	FWGM102
—	302	11-7/8	1-1/8	10	—	SC827	—	—	FWGM102
—	300	11-3/4	1-1/8	10	MC372	SC827	—	—	FWGM118
—	302	11-7/8	1-1/8	10	MC372	SC827	—	—	FWGM118
—	300	11-3/4	1-1/8	10	MC380	SC827	—	—	FWGM118
—	302	11-7/8	1-1/8	10	MC380	SC827	—	—	FWGM118
—	302	11-7/8	1-1/8	10	—	—	—	—	FWGMC126
—	302	11-7/8	1-1/8	10	—	—	—	—	FWGMC126
Y	228	9	1	14	—	—	—	—	—
—	232	9-1/8	1	14	—	—	—	—	—
Y	228	9	1	14	MC486	SC705	—	—	—
—	232	9-1/8	1	14	MC486	SC705	—	—	—
—	232	9-1/8	1-1/8	26	MC376	SC742	—	CF128	—
Y	232	9-1/8	1-1/8	26	MC378	SC746	—	—	—
Y	228	9	1	14	MC308	SC705	—	CF128	FWGM115
—	232	9-1/8	1	14	MC308	SC705	—	CF128	FWGM115
Y	228	9	1	14	MC308	SC705	—	CF126	FWGM115

Liter	CC/IN	Cyl	Years		Application Information	Kit
			To	From		

GMC LIGHT TRUCK, SUV & VAN continued

S-15, JIMMY, SONOMA continued

2.5	153	L4	1990	1993	Pre-Damped	04130
2.8	171	V6	1985	1987	Non Pre-Damped	04065
2.8	171	V6	1985	1987	Pre-Damped	04130
2.8	171	V6	1987	1987	Non Pre-Damped	04065
2.8	171	V6	1987	1987	Pre-Damped	04130
2.8	171	V6	1988	1988	Non Pre-Damped	04065
2.8	171	V6	1988	1988	Non Pre-Damped	04065
2.8	171	V6	1988	1988	Pre-Damped	04130
2.8	171	V6	1988	1988	Pre-Damped	04130
2.8	171	V6	1989	1989	Non Pre-Damped	04065
2.8	171	V6	1989	1989	Pre-Damped	04130
2.8	171	V6	1990	1993	Non Pre-Damped	04065
2.8	171	V6	1990	1993	Pre-Damped	04130
4.3	262	V6	1988	1995	—	04168
4.3	262	V6	1990	1991	—	04089
4.3	262	V6	1992	1993	—	04089
4.3	262	V6	1996	2004	—	KGM10

SAFARI

2.5	153	L4	1985	1989	—	04053
4.3	262	V6	1985	1989	—	04086

HONDA (Performance Applications Available)

ACCORD

1.6	1599	L4	1976	1978	—	08002
1.8	1751	L4	1982	1982	—	08007
1.8	1751	L4	1983	1984	—	08006
1.8	1829	L4	1985	1985	—	08006
2.0	1955	L4	1986	1989	—	08708
2.2	2156	L4	1990	1997	—	08014
2.3	2254	L4	1998	2002	—	HCK1000
2.4	2354	L4	2003	2007	Sold As Kit Only	HCK1005
2.4	2354	L4	2008	2012	Sold As Kit Only	HCK1009
2.4	2354	L4	2013	2017	Sold As Kit Only	HCK1014
3.0	2977	V6	2003	2006	Sold as kit only	HCK1007
3.5	3471	V6	2008	2010	Sold as kit only	HCK1007

CIVIC

1.2	1237	L4	1973	1979	—	08002
1.3	1335	L4	1980	1983	—	08003
1.3	1342	L4	1984	1987	—	08005
1.3	1339	L4	2003	2005	Hybrid, Sold as Kit Only	HCK1008
1.3	1339	L4	2006	2007	Hybrid, Sold as Kit Only	HCK1008
1.5	1487	L4	1975	1979	—	08004
1.5	1487	L4	1980	1983	—	08003
1.5	1487	L4	1984	1987	2 WD	08005
1.5	1487	L4	1985	1987	FWD;Hatchback	08015
1.5	1493	L4	1986	1986	2 WD	08005
1.5	1493	L4	1986	1986	4 WD Wagon	08015
1.5	1487	L4	1987	1987	4 WD Wagon	08015
1.5	1491	L4	1987	1987	2 WD	08005
1.5	1491	L4	1987	1987	4 WD Wagon	08015
1.5	1493	L4	1988	1988	2 WD	08009
1.5	1493	L4	1988	1988	4 WD	08010
1.5	1493	L4	1988	1988	FWD	08010
1.5	1493	L4	1989	1989	—	08011
1.5	1493	L4	1990	1990	—	08012
1.5	1493	L4	1991	1991	—	08012
1.5	1493	L4	1992	1995	—	08022
1.6	1590	L4	1988	1988	4 WD	08710

EXEDY OEM	Disc (mm)	Disc (in)	Spline Dia	Splines	Master Cylinder	Slave Cylinder	Clutch Cable	Clutch Fork	New Flywheel
—	232	9-1/8	1	14	MC308	SC705	—	CF126	FWGM115
Y	228	9	1	14	MC486	SC705	—	—	—
—	232	9-1/8	1	14	MC486	SC705	—	—	—
Y	228	9	1	14	MC309	SC827	—	—	—
—	232	9-1/8	1	14	MC309	SC827	—	—	—
Y	228	9	1	14	MC309	SC827	—	—	FWGMC123
Y	228	9	1	14	MC486	SC705	—	—	FWGMC123
—	232	9-1/8	1	14	MC309	SC827	—	—	FWGMC123
—	232	9-1/8	1	14	MC486	SC705	—	—	FWGMC123
Y	228	9	1	14	MC308	SC705	—	—	FWGMC123
—	232	9-1/8	1	14	MC308	SC705	—	—	FWGMC123
Y	228	9	1	14	MC308	SC705	—	CF126	FWGMC123
—	232	9-1/8	1	14	MC308	SC705	—	CF126	FWGMC123
—	280	11	1-1/8	10	MC376	SC743	—	—	FWGM108
—	280	11	1-1/8	10	MC308	SC745	—	—	FWGM108
—	280	11	1-1/8	10	MC373	SC743	—	—	FWGM108
—	280	11	1-1/8	10	MC378	SC746	—	—	FWGM108(1994-96)
—	225	8-7/8	15/16	14	MC305	SC703	—	—	FWGM115
—	280	11	1	14	MC305	SC703	—	—	FWGM108(1988-89)
—	190	7-1/2	1	19	MC230	SC637	—	—	—
—	200	7-7/8	7/8	21	—	—	CC508	—	—
Y	200	7-7/8	7/8	21	—	—	CC508	—	—
Y	200	7-7/8	7/8	21	—	—	CC509	—	—
—	210	8-1/4	7/8	21	—	—	CC503	—	HCF503
Y	225	8-7/8	1-1/16	24	MC234	SC642	—	—	FWHDA01
Y	210	8-1/4	1-1/16	24	MC466	SC868	—	—	—
Y	225	8-7/8	1-1/16	24	MC502	SC895	—	—	FWHDA02
Y	225	8-7/8	1	24	MC569	—	—	—	HCF001/HCF513
Y	230	9	1	24	—	—	—	—	—
—	238	9-3/8	1	24	MC502	—	—	—	—
—	238	9-3/8	1	24	MC502	—	—	—	—
—	190	7-1/2	1	19	—	—	—	—	—
—	190	7-1/2	1	19	—	—	—	—	—
—	190	7-1/2	1	19	—	—	CC511	—	—
—	219	8-5/8	27-32	20	MC553	—	—	—	—
—	219	8-5/8	27-32	20	—	—	—	—	—
—	190	7-1/2	1	19	—	—	—	—	—
—	190	7-1/2	1	19	—	—	CC511	—	—
—	190	7-1/2	1	19	—	—	CC511	—	—
—	190	7-1/2	1	19	—	—	CC511	—	—
—	190	7-1/2	1	19	—	—	CC511	—	—
—	190	7-1/2	1	19	—	—	CC511	—	—
—	190	7-1/2	1	19	—	—	CC511	—	—
—	190	7-1/2	1	19	—	—	CC511	—	—
—	190	7-1/2	1	19	—	—	CC511	—	—
—	190	7-1/2	1	19	—	—	CC511	—	—
—	190	7-1/2	7/8	21	—	—	CC514	—	—
—	200	7-7/8	7/8	21	—	—	CC514	—	HCF502
—	200	7-7/8	7/8	21	—	—	CC514	—	HCF502
Y	200	7-7/8	7/8	20	—	—	CC514	—	HCF502
Y	210	8-1/4	7/8	20	—	—	CC514	—	FWHDC01
Y	210	8-1/4	7/8	20	—	—	—	—	FWHDC01
Y	210	8-1/4	7/8	20	MC238	SC646	—	—	FWHDC01
—	210	8-1/4	7/8	20	—	—	—	—	—

2

Liter	CC/IN	Cyl	Years		Application Information	Kit
			To	From		
HONDA (Performance Applications Available) continued						
<i>CIVIC continued</i>						
1.6	1590	L4	1989	1989	2 WD	08011
1.6	1590	L4	1989	1989	4 WD	08019
1.6	1590	L4	1990	1990	2 WD	08012
1.6	1590	L4	1990	1991	4 WD	08020
1.6	1590	L4	1991	1991	—	08012
1.6	1590	L4	1992	2000	SOHC, Except SI	08022
1.6	1595	L4	1999	2000	DOHC, SI	KHC05
1.7	1700	L4	2001	2005	Sold As Kit Only	KHC08
1.8	1799	L4	2006	2009	Sold As Kit Only	HCK1002
1.8	1799	L4	2010	2015	Sold As Kit Only	HCK1002
2.0	1998	L4	2002	2005	SI, Sold As Kit Only	KHC09
2.0	1998	L4	2006	2008	SI, Sold As Kit Only	KHC10
2.0	1998	L4	2009	2011	SI, Sold As Kit Only	HCK1011
2.0	1998	L4	2016	2019	—	HCK1014
2.4	2354	L4	2012	2015	SI	HCK1015
<i>CIVIC DEL SOL</i>						
1.5	1493	L4	1993	1994	—	08022
1.5	1493	L4	1995	1995	SI	08022
1.6	1590	L4	1993	1995	SI	08022
1.6	1590	L4	1994	1994	VTEC	KHC05
1.6	1590	L4	1995	1995	Non-VTEC	KHC05
1.6	1590	L4	1996	1997	Non-VTEC	08031
1.6	1590	L4	1996	1997	VTEC	KHC05
<i>CRX</i>						
1.3	1342	L4	1984	1984	—	08005
1.5	1487	L4	1984	1987	—	08005
1.5	1493	L4	1988	1988	—	08009
1.5	1493	L4	1989	1989	—	08011
1.5	1493	L4	1990	1991	—	08012
1.6	1590	L4	1988	1988	—	08010
1.6	1590	L4	1989	1989	—	08011
1.6	1590	L4	1990	1991	—	08012
<i>FIT</i>						
1.5	1497	L4	2007	2008	Sold As Kit Only	HCK1006
1.5	1497	L4	2009	2013	Sold As Kit Only	HCK1010
<i>INSIGHT</i>						
1.0	995	L3	2000	2006	—	KHC11
<i>PRELUDE</i>						
1.8	1829	L4	1983	1987	—	08006
2.0	1955	L4	1985	1987	—	08708
2.0	1958	L4	1988	1989	—	08013
2.2	2156	L4	1992	2001	—	KHC03
2.3	2259	L4	1992	1996	—	KHC03
<i>S2000</i>						
2.0	1997	L4	2000	2003	Pull Type clutch	KHC06
2.2	2157	L4	2004	2009	Pull Type clutch	KHC06
HONDA SUV & VAN						
<i>CR-V</i>						
2.0	1972	L4	1998	2001	—	KHC05
2.4	2354	L4	2002	2006	Sold As Kit Only	HCK1004
<i>ELEMENT</i>						
2.4	2354	L4	2003	2009	Sold As Kit Only	HCK1004
<i>PASSPORT</i>						
2.6	2559	L4	1994	1996	—	KIS05
3.2	3165	V6	1994	1997	Sold As Kit Only	KIS01
3.2	3165	V6	1998	2002	Sold As Kit Only	KIS01

2

EXEDY OEM	Disc (mm)	Disc (in)	Spline Dia	Splines	Master Cylinder	Slave Cylinder	Clutch Cable	Clutch Fork	New Flywheel
Y	200	7-7/8	7/8	20	—	—	—	—	HCF502
—	200	7-7/8	7/8	20	—	—	—	—	—
Y	210	8-1/4	7/8	20	—	—	—	—	FWHDC01
—	210	8-1/4	7/8	20	—	—	—	—	FWHDC01
Y	210	8-1/4	7/8	20	—	—	—	—	FWHDC01
Y	210	8-1/4	7/8	20	MC238	SC646	—	—	FWHDC01 (92-96)
Y	219	8-5/8	1-1/16	24	MC238	SC646	—	—	HCF500
Y	210	8-1/4	7/8	20	MC553	SC896	—	—	FWHDC02FF
Y	215	8-1/2	7/8	20	MC569	SC898	—	—	FWHDC03
Y	215	8-1/2	7/8	20	—	SC898	—	—	FWHDC03
Y	215	8-1/2	1-1/16	24	MC502	SC895	—	—	HCF514
Y	215	8-1/2	1-1/32	24	MC569	SC899	—	—	HCF512
Y	215	8-1/2	1-1/32	24	MC569	SC899	—	—	HCF512
Y	230	9	1	24	—	—	—	—	—
—	219	8-5/8	1-1/32	24	—	—	—	—	—
Y	210	8-1/4	7/8	20	MC238	SC646	—	—	FWHDC01
Y	210	8-1/4	7/8	20	MC238	SC646	—	—	FWHDC01
Y	210	8-1/4	7/8	20	MC238	SC646	—	—	FWHDC01
Y	219	8-5/8	1-1/16	24	MC238	SC646	—	—	HCF500
Y	219	8-5/8	1-1/16	24	MC238	SC646	—	—	FWHDC01
Y	200	7-7/8	7/8	20	MC238	SC646	—	—	HCF502
Y	219	8-5/8	1-1/16	24	MC238	SC646	—	—	HCF500
—	190	7-1/2	1	19	—	—	—	—	—
—	190	7-1/2	1	19	—	—	CC511	—	—
—	190	7-1/2	7/8	21	—	—	CC514	—	—
Y	200	7-7/8	7/8	20	—	—	CC514	—	HCF502
Y	210	8-1/4	7/8	20	—	—	CC514	—	—
—	200	7-7/8	7/8	21	—	—	CC514	—	HCF502
Y	200	7-7/8	7/8	20	—	—	CC514	—	HCF502
Y	210	8-1/4	7/8	20	—	—	CC514	—	—
Y	190	7-1/2	7/8	20	MC570	SC897	—	—	—
—	190	7-1/2	7/8	20	—	SC898	—	—	HCF510
—	190	7-1/2	7/8	20	—	—	—	—	—
Y	200	7-7/8	7/8	21	—	—	CC505	—	HCF503
—	210	8-1/4	7/8	21	—	—	CC515	—	HCF503
—	213	8-3/8	1	24	MC233	SC639	—	—	—
—	219	8-5/8	1-1/16	24	MC234	SC642	—	—	FWHDA01
—	219	8-5/8	1-1/16	24	MC234	SC642	—	—	—
—	213	8-3/8	1-1/32	24	—	—	—	—	—
—	213	8-3/8	1-1/32	24	—	—	—	—	—
Y	219	8-5/8	1-1/16	24	MC526	SC646	—	—	HCF500
Y	228	9	1-1/32	24	MC502	SC895	—	—	—
Y	228	9	1-1/32	24	MC502	SC895	—	—	—
Y	240	9-1/2	1	24	MC144	SC552	—	—	ISF500
Y	260	10-1/4	1	24	MC144	SC550	—	—	ISF502
Y	260	10-1/4	1	24	MC554	SC550	—	—	ISF502

Liter	CC/IN	Cyl	Years		Application Information	Kit
			To	From		
HUMMER						
<i>H3</i>						
3.5	214	L5	2006	2006	Sold as Kit Only	GMK1028
3.7	223	L5	2007	2010	Sold as Kit Only	GMK1028
HYUNDAI						
<i>ACCENT</i>						
1.5	1495	L4	1995	1995	—	05091
1.5	1495	L4	1995	1995	—	05091
1.5	1495	L4	1996	1997	—	05091
1.5	1495	L4	1997	1999	—	05091
1.5	1495	L4	2000	2002	—	05091
1.6	1600	L4	2001	2003	—	HYK1000
1.6	1600	L4	2004	2005	—	HYK1000
1.6	1599	L4	2006	2008	Sold as Kit Only	HYK1004
1.6	1599	L4	2009	2011	Sold as Kit Only	HYK1012
<i>ELANTRA</i>						
1.6	1596	L4	1992	1993	To 9/30/93	05022
1.6	1596	L4	1993	1995	From 10/1/93	05051
1.8	1796	L4	1996	1998	Pull Type Design,Sold as kit only	05087
1.8	1796	L4	2011	2014	Sold as Kit Only	KIK1004
2.0	1975	L4	1999	2000	Pull Type Design,Sold as kit only	05087
2.0	1975	L4	2001	2004	Pull Type Design,Sold as kit only	05087
2.0	1975	L4	2005	2005	Pull Type Design,Sold as kit only	05087
2.0	1975	L4	2006	2006	Pull Type Design,Sold as kit only	05087
2.0	1975	L4	2007	2012	Sold as Kit Only	HYK1005
<i>EXCEL</i>						
1.5	1468	L4	1986	1988	—	05008
1.5	1468	L4	1989	1989	To 6/89	05008
1.5	1468	L4	1990	1994	—	05022
<i>PONY (CANADA)</i>						
1.4	1393	L4	1983	1987	—	05008
1.5	1468	L4	1986	1986	—	05008
1.6	1596	L4	1984	1987	—	05008
<i>SCOUPE</i>						
1.5	1468	L4	1991	1992	Non-Turbo	05022
1.5	1495	L4	1993	1993	Non-Turbo	05022
1.5	1495	L4	1993	1995	Turbo	05051
<i>SONATA</i>						
2.0	1997	L4	1992	1992	—	05051
2.0	1997	L4	1993	1993	—	05051
2.0	1997	L4	1994	1994	From 11/94	05056
2.0	1997	L4	1994	1994	To 10/94	05051
2.0	1997	L4	1995	1998	—	05056
2.4	2351	L4	1989	1991	—	05056
2.4	2351	L4	1999	2001	Pull Type Design	05100
2.4	2351	L4	2002	2002	Pull Type Design,6spd,Fits OEM Dual Mass FW	KHY01
2.4	2351	L4	2003	2005	Pull Type Design,6spd,Fits OEM Dual Mass FW	KHY01
2.5	2493	V6	1999	2001	Pull Type Design	05100
2.7	2656	V6	2002	2002	Pull Type Design,6spd,Solid FW Conversion,Sold as kit only, Includes FW	HYK1003
2.7	2656	V6	2003	2003	Pull Type Design,6spd,Solid FW Conversion,Sold as kit only, Includes FW	HYK1003
2.7	2656	V6	2002	2002	Pull Type Design,6spd,Fits OEM Dual Mass FW	KHY01
2.7	2656	V6	2003	2003	Pull Type Design,6spd,Fits OEM Dual Mass FW	KHY01
2.7	2656	V6	2005	2005	Pull Type Design	KHY01

2

EXEDY OEM	Disc (mm)	Disc (in)	Spline Dia	Splines	Master Cylinder	Slave Cylinder	Clutch Cable	Clutch Fork	New Flywheel
—	265	10-7/16	1-3/16	26	MC462	SC809	—	—	—
—	265	10-7/16	1-3/16	26	MC462	SC809	—	—	—
—	200	7-7/8	7/8	20	MC538	SC840	—	—	—
—	200	7-7/8	7/8	20	MC538	SC855	—	—	—
—	200	7-7/8	7/8	20	MC538	SC590	—	—	—
—	200	7-7/8	7/8	20	MC557	SC590	—	—	—
—	200	7-7/8	7/8	20	MC517	SC855	—	—	—
—	215	8-7/16	7/8	20	MC517	SC855	—	—	—
—	215	8-7/16	7/8	20	MC519	SC855	—	—	—
—	215	8 7/16	7/8	20	MC518	SC913	—	—	—
—	215	8 7/16	7/8	20	MC518	SC913	—	—	—
Y	200	7-7/8	7/8	20	MC178	SC581	—	—	—
Y	215	8-1/2	7/8	20	MC178	SC581	—	—	—
—	215	8-7/16	7/8	20	MC555	SC849	—	—	—
—	236	9-1/4	7/8	20	—	SC913	—	—	—
—	215	8-7/16	7/8	20	MC555	SC596	—	—	—
—	215	8-7/16	7/8	20	MC562	SC596	—	—	—
—	215	8-7/16	7/8	20	MC512	SC596	—	—	—
—	215	8-7/16	7/8	20	MC512	SC849	—	—	—
—	225	8-7/8	7/8	20	—	SC913	—	—	—
—	184	7-1/4	7/8	20	—	—	CC550	—	—
—	184	7-1/4	7/8	20	MC178	SC584	CC550	—	—
Y	200	7-7/8	7/8	20	MC178	SC584	—	—	—
—	184	7-1/4	7/8	20	—	—	—	—	—
—	184	7-1/4	7/8	20	—	—	—	—	—
—	184	7-1/4	7/8	20	—	—	—	—	—
Y	200	7-7/8	7/8	20	MC178	SC584	—	—	—
Y	200	7-7/8	7/8	20	MC184	SC590	—	—	—
Y	215	8-1/2	7/8	20	MC184	SC590	—	—	—
Y	215	8-1/2	7/8	20	MC175	SC581	—	—	—
Y	215	8-1/2	7/8	20	MC187	SC581	—	—	—
Y	225	8-7/8	7/8	20	MC189	SC581	—	—	—
Y	215	8-1/2	7/8	20	MC187	SC581	—	—	—
Y	225	8-7/8	7/8	20	MC189	SC581	—	—	—
Y	225	8-7/8	7/8	20	MC175	SC580	—	—	—
—	225	8-7/8	7/8	20	MC560	SC849	—	—	—
—	225	8-7/8	7/8	20	MC560	SC850	—	—	—
—	225	8-7/8	7/8	20	MC560	SC849	—	—	—
—	225	8-7/8	7/8	20	—	SC849	—	—	—
—	225	8-7/8	7/8	20	—	—	—	—	—
—	225	8-7/8	7/8	20	—	—	—	—	—
—	225	8-7/8	7/8	20	MC560	SC849	—	—	—
—	225	8-7/8	7/8	20	—	—	—	—	—
—	225	8-7/8	7/8	20	MC560	SC849	—	—	—
—	225	8-7/8	7/8	20	MC560	—	—	—	—

2

Liter	CC/IN	Cyl	Years		Application Information	Kit
			To	From		
TIBURON						
1.8	1795	L4	1997	1997	Pull Type Design,Sold as kit only	05087
2.0	1975	L4	1997	2001	Pull Type Design,Sold as kit only	05087
2.0	1975	L4	2003	2007	Pull Type Design,5spd, Sold as Kit Only	05087
2.7	2656	V6	2003	2007	Pull Type Design,5spd, Sold as Kit Only, Fits Solid FW set up	05087
2.7	2656	V6	2003	2007	Pull Type Design,5spd, Sold as Kit Only, Fits Dual Mass FW set up	KHY01
2.7	2656	V6	2003	2007	Pull Type Design,6spd,Fits OEM Dual Mass FW	KHY01
2.7	2656	V6	2003	2008	Pull Type Design,6spd,Solid FW Conversion,Sold as kit only, Includes FW	HYK1003
TUCSON						
2.0	1975	L4	2005	2009	—	HYK1001
VELOSTER						
1.6	1597	L4	2012	2015	Sold as Kit Only	KIK1002
HYUNDAI SUV						
SANTA FE						
2.4	2351	L4	2001	2004	Pull Type Design, Fits Dual Mass FW	KHY01
2.4	2351	L4	2001	2006	Pull Type Design, Fits Solid FW	HYK1002
INFINITI (Performance Applications Available)						
G20						
2.0	1998	L4	1991	1996	—	KNS02
2.0	2000	L4	1999	2002	—	KNS02
G35						
3.5	3498	V6	2003	2006	Sold As Kit Only	NSK1000
3.5	3498	V6	2003	2006	Sold As Kit Only, Solid FW Conversion for OEM Dual Mass FW	NSK1000FW
3.5	3498	V6	2007	2007	Sold As Kit Only	NSK1000
3.5	3498	V6	2007	2007	Sold As Kit Only, Solid FW Conversion for OEM Dual Mass FW, Coupe only	NSK1000FW
3.5	3498	V6	2007	2011	Sold As Kit Only, Solid FW Conversion for OEM Dual Mass FW, Sedan Only	NSK1024FW
3.5	3498	V6	2007	2011	For OEM Dual Mass FW	NSK1037
G37						
3.7	3696	V6	2008	2015	Dual Mass Flywheel Conversion, Sold as Kit Only, Includes Solid Flywheel, Includes CSC Hydraulic Slave	NSK1024FW
3.7	3696	V6	2008	2015	For OEM Dual Mass FW	NSK1037
I30						
3.0	2988	V6	1996	1999	—	06044
ISUZU						
I-280, I-290						
2.8	2770	L4	2006	2006	Sold as Kit Only, Includes CSC Hydraulic Slave	GMK1015
I-MARK						
1.5	1471	L4	1985	1989	Non-Turbo	04063
1.5	1471	L4	1987	1989	Turbo	04099
1.8	1817	L4	1981	1984	Diesel	04058
1.8	1817	L4	1981	1985	—	04058
IMPULSE						
1.6	1588	L4	1990	1991	Non-Turbo	04112
1.6	1588	L4	1991	1992	Turbo	09017
1.8	1817	L4	1992	1992	—	09017
1.9	1949	L4	1983	1987	—	09012
2.0	1994	L4	1985	1989	Turbo	09007
2.3	2254	L4	1988	1989	—	09014
STYLUS						
1.6	1588	L4	1991	1993	—	04112
1.8	1817	L4	1992	1992	—	09017

2

EXEDY OEM	Disc (mm)	Disc (in)	Spline Dia	Splines	Master Cylinder	Slave Cylinder	Clutch Cable	Clutch Fork	New Flywheel
—	215	8-7/16	7/8	20	—	—	—	—	—
—	215	8-7/16	7/8	20	MC555	SC849	—	—	—
—	215	8-7/16	7/8	20	MC562	SC849	—	—	—
—	215	8-7/16	7/8	20	MC562	SC849	—	—	—
—	225	8-7/8	7/8	20	MC562	SC849	—	—	—
—	225	8-7/8	7/8	20	MC562	SC911	—	—	—
—	225	8-7/8	7/8	20	MC562	SC911	—	—	—
—	236	9-1/4	7/8	20	MC513	SC849	—	—	—
—	215	8-7/16	7/8	20	—	—	—	—	—
—	225	8-7/8	7/8	20	MC514	SC849	—	—	—
—	225	8-7/8	7/8	20	—	—	—	—	—
Y	215	8-1/2	13/16	18	—	—	—	—	NSF504
Y	215	8-1/2	13/16	18	—	SC760	—	—	NSF504
—	250	9-7/8	1	24	—	—	—	—	—
Y	250	9-7/8	1	24	—	—	—	—	—
—	250	9-7/8	1	24	—	—	—	—	—
—	250	9-7/8	1	24	—	—	—	—	—
—	250	9-7/8	1	24	—	BRG0163	—	—	—
—	250	9-7/8	1	24	—	BRG0163	—	—	—
—	250	9-7/8	1	24	—	BRG0163	—	—	—
—	250	9-7/8	1	24	—	BRG0163	—	—	—
—	240	9-1/2	1	24	MC160	SC851	—	—	—
—	264	10-3/8	1-1/8	26	MC462	—	—	—	—
Y	184	7-1/4	1	14	—	—	CC578	—	—
Y	215	8-1/2	1	14	—	—	CC578	—	—
Y	200	7-7/8	1	24	—	—	—	—	—
Y	200	7-7/8	1	24	—	—	—	—	—
Y	200	7-7/8	15/16	14	—	—	—	—	—
Y	215	8-1/2	1	14	—	—	—	—	—
Y	215	8-1/2	1	14	—	—	—	—	—
Y	215	8-1/2	1	24	MC142	SC545	—	—	ISF501
Y	240	9-1/2	1	24	MC142	SC546	—	—	—
Y	215	8-1/2	1	24	MC142	SC546	—	—	ISF501
Y	200	7-7/8	15/16	14	—	—	—	—	—
Y	215	8-1/2	1	14	—	—	—	—	—

2

Liter	CC/IN	Cyl	Years		Application Information	Kit
			To	From		

ISUZU LIGHT TRUCK & SUV

AMIGO

2.2	2180	L4	1998	2000	MUA Transmission, ID # RMN	KIS05
2.3	2254	L4	1989	1990	—	04071
2.3	2254	L4	1991	1993	—	04071
2.6	2559	L4	1989	1990	—	09015
2.6	2559	L4	1991	1994	—	09015
3.2	3165	V6	1998	2000	Sold As Kit Only, Pull Type	KIS01

HOMBRE

2.2	2180	L4	1996	2000	—	04155
4.3	4294	V6	1997	1999	—	KGM10

PICKUP

1.8	1817	L4	1981	1982	2 WD	04058
1.8	1817	L4	1981	1982	4 WD	04071
1.9	1949	L4	1983	1987	—	04071
2.2	2238	L4	1981	1985	Diesel	04071
2.2	2238	L4	1986	1987	Turbo Diesel	04071
2.3	2254	L4	1986	1995	—	04071
2.6	2559	L4	1988	1995	—	09015
3.1	3137	V6	1991	1994	—	09018

RODEO

2.2	2180	L4	1998	1998	1 Piece Bell Housing	09015
2.2	2180	L4	1998	1998	2 Piece Bell Housing	KIS05
2.2	2180	L4	1999	2000	2 Piece Bell Housing	KIS05
2.2	2180	L4	1999	2001	1 Piece Bell Housing	09015
2.2	2180	L4	2002	2003	—	ISK1002
2.6	2559	L4	1991	1992	To 10/92	09015
2.6	2559	L4	1992	1992	From 11/92	KIS05
2.6	2559	L4	1993	1997	—	KIS05
3.1	3137	V6	1991	1991	2 WD, Non Pre-Damped	04065
3.1	3137	V6	1991	1991	2 WD, Pre-Damped	04130
3.1	3137	V6	1991	1992	4 WD, MUA Transmission # RMN	09018
3.1	3137	V6	1991	1992	4 WD, Transmission # MM5	04065
3.1	3137	V6	1992	1992	2 WD, Non Pre-Damped	04065
3.1	3137	V6	1992	1992	2 WD, Pre-Damped	04130
3.2	3165	V6	1993	1993	Borg Warner Transmission	KIS05
3.2	3165	V6	1993	1993	MUA Transmission, Sold As Kit Only, Pull Type	KIS01
3.2	3165	V6	1994	1995	Sold As Kit Only, Pull Type	KIS01
3.2	3165	V6	1996	1997	Borg Warner Transmission	KIS05
3.2	3165	V6	1996	1997	MUA Transmission, Sold As Kit Only, Pull Type	KIS01
3.2	3165	V6	1998	1999	Borg Warner Transmission	KIS05
3.2	3165	V6	1998	1999	MUA Transmission, Sold As Kit Only, Pull Type	KIS01
3.2	3165	V6	2000	2004	Sold As Kit Only, Pull Type	KIS01

TROOPER

1.9	1949	L4	1984	1985	—	04071
2.2	2238	L4	1984	1984	Diesel	04071
2.2	2238	L4	1986	1987	Turbo Diesel	04071
2.3	2254	L4	1986	1987	—	04071
2.6	2559	L4	1988	1991	—	09015
2.8	2827	V6	1989	1991	—	09016
3.2	3165	V6	1992	1997	Sold As Kit Only, Pull Type	KIS01
3.5	3475	V6	1998	2002	Sold As Kit Only, Pull Type	KIS06

JEEP LIGHT TRUCK & SUV

CHEROKEE, GRAND CHEROKEE, COMANCHE, WAGONEER, GRAND WAGONEER

2.5	153	L4	1986	1986	8-7/8" Disc	01020
2.5	153	L4	1987	1990	Includes Slave Cylinder	01033
2.5	153	L4	1991	1992	Includes Slave Cylinder	01033
2.5	153	L4	1993	1993	Includes Slave Cylinder	01036

	EXEDY OEM	Disc (mm)	Disc (in)	Spline Dia	Splines	Master Cylinder	Slave Cylinder	Clutch Cable	Clutch Fork	New Flywheel
	Y	240	9-1/2	1	24	MC146	SC875	—	—	—
	Y	215	8-1/2	1	24	—	—	CC581	—	—
	Y	215	8-1/2	1	24	—	—	—	—	—
	Y	240	9-1/2	1	24	MC144	SC549	CC581	—	—
	Y	240	9-1/2	1	24	MC144	SC547	—	—	—
	Y	260	10-1/4	1	24	MC554	SC550	—	—	—
	Y	232	9-1/8	1-1/8	26	MC378	SC746	—	—	—
	—	280	11	1-1/8	10	MC378	SC746	—	—	—
	Y	200	7-7/8	1	24	—	—	—	—	—
	Y	215	8-1/2	1	24	—	—	—	—	—
	Y	215	8-1/2	1	24	—	—	—	—	ISF501
	Y	215	8-1/2	1	24	—	—	—	—	ISF501
	Y	215	8-1/2	1	24	MC493	—	—	—	ISF501
	Y	215	8-1/2	1	24	—	—	—	—	ISF501
	Y	240	9-1/2	1	24	MC144	SC549	—	—	ISF500
	Y	240	9-1/2	1	24	MC144	SC548	—	—	—
	Y	240	9-1/2	1	24	MC146	SC904	—	—	—
	Y	240	9-1/2	1	24	MC146	SC904	—	—	—
	Y	240	9-1/2	1	24	MC146	SC875	—	—	—
	Y	240	9-1/2	1	24	MC146	SC875	—	—	—
	Y	240	9-1/2	1	24	MC554	SC875	—	—	—
	Y	240	9-1/2	1	24	MC144	SC549	—	—	—
	Y	240	9-1/2	1	24	MC144	SC552	—	—	—
	Y	240	9-1/2	1	24	MC144	SC552	—	—	ISF500
	Y	228	9	1	14	MC144	SC548	—	—	—
	—	232	9-1/8	1	14	MC144	SC548	—	—	—
	Y	240	9-1/2	1	24	MC144	SC548	—	—	—
	Y	228	9	1	14	MC144	SC551	—	—	—
	Y	228	9	1	14	MC144	—	—	—	—
	—	232	9-1/8	1	14	MC144	—	—	—	—
	Y	240	9-1/2	1	24	MC144	SC550	—	—	—
	Y	260	10-1/4	1	24	MC144	SC550	—	—	—
	Y	260	10-1/4	1	24	MC144	SC550	—	—	—
	Y	240	9-1/2	1	24	MC144	SC550	—	—	—
	Y	260	10-1/4	1	24	MC144	SC550	—	—	—
	Y	240	9-1/2	1	24	MC554	SC550	—	—	—
	Y	260	10-1/4	1	24	MC554	SC550	—	—	ISF502
	Y	260	10-1/4	1	24	MC144	SC550	—	—	ISF502
	Y	215	8-1/2	1	24	—	—	—	—	ISF501
	Y	215	8-1/2	1	24	—	—	—	—	ISF501
	Y	215	8-1/2	1	24	—	—	—	—	ISF501
	Y	215	8-1/2	1	24	—	—	—	—	ISF501
	Y	240	9-1/2	1	24	MC143	SC549	—	—	—
	Y	230	9-1/16	1	24	MC143	SC548	—	—	—
	Y	260	10-1/4	1	24	MC144	SC550	—	—	—
	Y	273	10-3/4	1	24	—	SC550	—	—	—
	—	225	8-7/8	15/16	14	MC346	SC723	—	—	—
	—	225	8-7/8	15/16	14	MC342	—	—	—	—
	—	225	8-7/8	15/16	14	MC390	—	—	—	CRF502
	—	225	8-7/8	15/16	14	MC390	—	—	—	CRF502

2

Liter	CC/IN	Cyl	Years		Application Information	Kit
			To	From		
JEEP LIGHT TRUCK & SUV continued						
<i>CHEROKEE, GRAND CHEROKEE, COMANCHE, WAGONEER, GRAND WAGONEER continued</i>						
2.5	153	L4	1994	1996	—	01040
2.5	153	L4	1997	2000	—	01040
2.8	171	V6	1985	1985	9-1/8" Disc	01024
2.8	171	V6	1985	1986	—	01024
3.8	232	L6	1965	1965	—	01026
3.8	232	L6	1971	1971	Includes Slave Cylinder	01035
4.0	244	L6	1987	1988	Includes Slave Cylinder	01035
4.0	244	L6	1989	1989	Aisin Transmission, Includes Slave Cylinder	01034
4.0	244	L6	1989	1989	Aisin Transmission, Includes Slave Cylinder	01034
4.0	244	L6	1989	1989	Peugeot Transmission, Includes Slave Cylinder	01035
4.0	244	L6	1989	1989	Peugeot Transmission, Includes Slave Cylinder	01035
4.0	244	L6	1990	1990	Includes Slave Cylinder	01034
4.0	244	L6	1991	1992	Includes Slave Cylinder	01034
4.0	244	L6	1993	1993	Includes Slave Cylinder	01037
4.0	244	L6	1993	1993	Includes Slave Cylinder	01037
4.0	244	L6	1994	1994	—	05065
4.0	244	L6	1994	1996	—	05065
4.0	244	L6	1997	2001	—	05065
4.2	256	L6	1972	1974	10-3/8" Disc	01026
4.2	256	L6	1975	1975	—	01026
4.2	256	L6	1982	1986	—	01017
CJ SERIES, SCRAMBLER, WRANGLER						
2.4	146	L4	2003	2004	—	KJP03
2.4	146	L4	2005	2006	Sold as Kit Only	CRK1007
2.5	153	L4	1986	1986	—	01020
2.5	153	L4	1987	1987	Includes Slave Cylinder	01033
2.5	153	L4	1988	1990	Includes Slave Cylinder	01033
2.5	153	L4	1991	1991	Includes Slave Cylinder	01033
2.5	153	L4	1991	1992	Includes Slave Cylinder	01033
2.5	153	L4	1993	1993	Includes Slave Cylinder	01036
2.5	153	L4	1994	1995	—	01040
2.5	153	L4	1997	2002	—	01040
3.8	232	L6	1972	1973	—	01026
3.8	232	L6	1974	1975	—	01026
3.8	232	L6	2007	2011	Sold as Kit Only	KJP02
4.0	244	L6	1991	1992	Includes Slave Cylinder	01034
4.0	244	L6	1993	1993	Includes Slave Cylinder	01037
4.0	244	L6	1994	1995	—	05065
4.0	244	L6	1997	2004	—	05065
4.0	244	L6	2005	2006	—	05065
4.2	256	L6	1972	1975	10-1/2" Disc	01026
4.2	256	L6	1976	1981	CJ5, CJ7	01017
4.2	256	L6	1982	1985	—	01017
4.2	256	L6	1986	1986	—	01007
4.2	256	L6	1987	1988	Includes Slave Cylinder	01035
4.2	256	L6	1989	1989	Aisin Transmission, Includes Slave Cylinder	01034
4.2	256	L6	1989	1989	Peugeot Transmission, Includes Slave Cylinder	01035
4.2	256	L6	1990	1990	Includes Slave Cylinder	01034
5.0	305	V8	1972	1975	10" Disc	01026
DJ SERIES						
3.8	232	L6	1972	1973	—	01026
3.8	232	L6	1974	1974	—	01026
4.2	256	L6	1973	1974	10-3/8" Disc	01026
5.0	305	V8	1974	1974	10-3/8" Disc	01026
GLADIATOR						
3.8	232	L6	1966	1967	—	01026

2

Liter	CC/IN	Cyl	Years		Application Information	Kit
			To	From		
JEEP LIGHT TRUCK & SUV continued						
<i>J SERIES</i>						
3.8	232	L6	1966	1971	—	01026
4.2	256	L6	1972	1973	—	01026
4.2	256	L6	1973	1973	—	01026
4.2	256	L6	1982	1985	—	01017
4.2	256	L6	1986	1986	—	01007
4.2	256	L6	1987	1987	Includes Slave Cylinder	01035
<i>JEEPSTER</i>						
3.8	232	L6	1972	1973	—	01026
4.2	256	L6	1972	1973	10-3/8" Disc	01026
<i>LIBERTY</i>						
2.4	146	L4	2002	2004	—	KJP01
2.4	146	L4	2005	2005	Sold as Kit Only	CRK1007
3.7	226	V6	2002	2004	Sold As Kit Only, Sprung Disc	KJP02
3.7	226	V6	2005	2006	Sold as Kit Only, Rigid Disc	CRK1006
KIA						
<i>FORTE</i>						
2.0	1975	L4	2010	2013	Sold as Kit Only	KIK1004
<i>RIO</i>						
1.5	1493	L4	2001	2002	—	KKI02
1.6	1594	L4	2003	2005	—	KKI02
1.6	1599	L4	2006	2009	To 02/01/2009	HYK1008EX
1.6	1599	L4	2012	2014	—	KIK1002
<i>SEPHIA</i>						
1.6	1597	L4	1994	1997	—	10040
1.8	1839	L4	1995	1997	—	KKI01
1.8	1793	L4	1998	1998	—	10040
1.8	1793	L4	1998	1999	—	KKI01
1.8	1793	L4	2000	2001	—	KKI01
<i>SORENTO</i>						
3.5	3497	V6	2004	2006	Sold as kit only	KIK1001
<i>SPECTRA</i>						
1.8	1793	L4	2000	2004	—	KKI01
2.0	1975	L4	2004	2009	Sold as kit only	KIK1000
KIA SUV						
<i>SPORTAGE</i>						
2.0	1998	L4	1995	2002	—	KKI01
2.0	1975	L4	2005	2008	—	HYK1001
<i>SOUL</i>						
1.6	1597	L4	2010	2014	Sold as Kit Only	KIK1002
2.0	1975	L4	2010	2011	Sold as Kit Only	HYK1005
2.0	1975	L4	2012	2013	Sold as Kit Only	KIK1004
LAND ROVER						
<i>DEFENDER</i>						
3.9	3950	V8	1993	1995	Sold As Kit Only	KLR09
<i>DISCOVERY</i>						
3.9	3950	V8	1994	1995	Sold As Kit Only	KLR10
4.0	3950	V8	1996	1997	Sold As Kit Only	KLR10
LEXUS (Performance Applications Available)						
<i>ES250</i>						
2.5	2508	V6	1990	1991	—	16082
3.0	2959	V6	1992	1993	—	16082
<i>IS300</i>						
3.0	2997	L6	2002	2003	—	KTY17
<i>SC300</i>						
3.0	2997	L6	1992	1997	—	16085

2

EXEDY OEM	Disc (mm)	Disc (in)	Spline Dia	Splines	Master Cylinder	Slave Cylinder	Clutch Cable	Clutch Fork	New Flywheel
—	265	10-1/2	1-1/8	10	—	—	—	—	—
—	265	10-1/2	1-1/8	10	—	—	—	—	—
—	265	10-1/2	1-1/8	10	—	—	—	CF111	—
—	265	10-1/2	1-1/8	10	—	—	—	—	—
—	265	10-1/2	1-1/8	10	—	—	—	—	—
—	265	10-1/2	1-1/8	10	—	—	—	—	—
—	265	10-1/2	1-1/8	10	—	—	—	—	—
—	265	10-1/2	1-1/8	10	—	—	—	—	—
—	228	9	1	19	MC455	SC798	—	—	—
—	226	8-15/16	15/16	19	MC455	SC934	—	—	—
—	263	10-3/8	1-3/8	10	MC455	SC798	—	—	—
—	265	10-7/16	1-1/8	10	MC455	—	—	—	—
—	236	9-1/4	7/8	20	—	SC913	—	—	—
—	200	7-7/8	7/8	20	—	—	—	—	—
—	200	7-7/8	7/8	20	—	—	—	—	—
—	215	8-1/2	7/8	20	—	—	—	—	—
—	215	8-7/16	7/8	20	—	—	—	—	—
Y	200	7-7/8	7/8	20	MC225	SC628	—	—	—
—	225	8-7/8	15/16	22	MC225	SC629	—	—	—
Y	200	7-7/8	7/8	20	MC225	SC633	—	—	—
—	225	8-7/8	15/16	22	MC559	SC633	—	—	—
—	225	8-7/8	15/16	22	MC225	SC633	—	—	—
—	240	9-1/2	1	23	MC576	—	—	—	—
—	225	8-7/8	15/16	22	MC559	SC859	—	—	—
—	215	8-1/2	13/16	20	—	SC849	—	—	—
—	225	8-7/8	15/16	22	MC226	SC635	—	—	—
—	236	9-1/4	7/8	20	MC513	SC849	—	—	—
—	215	8-7/16	7/8	20	—	—	—	—	—
—	225	8-7/8	7/8	20	—	—	—	—	—
—	236	9-1/4	7/8	20	—	SC913	—	—	—
—	265	10-1/2	1	23	—	—	—	—	—
—	265	10-1/2	1	23	—	SC810	—	—	—
—	265	10-1/2	1	23	—	SC810	—	—	—
—	236	9-1/4	1-3/16	21	MC246	SC653	—	—	—
—	236	9-1/4	1-3/16	21	MC540	SC654	—	—	—
—	238	9-3/8	1-3/16	21	—	—	—	—	—
—	236	9-1/4	1-3/16	21	MC268	SC674	—	—	—

2

Liter	CC/IN	Cyl	Years		Application Information	Kit
			To	From		
LINCOLN						
LS						
3.0	—	V6	2000	2002	Includes Slave Cylinder	KLN01
MAZDA (Performance Applications Available)						
2						
1.5	1498	L4	2011	—	Sold as Kit Only	MZK1010
3						
2.0	2000	L4	2004	2014	Sold As Kit Only	MZK1003
2.0	2000	L4	2012	2015	Skyactiv	MZK1012
2.3	2260	L4	2004	2009	Sold As Kit Only	MZK1003
2.5	2488	L4	2009	2013	Sold As Kit Only	MZK1009
323, GLC						
1.3	1272	L4	1977	1978	—	10004
1.4	1415	L4	1979	1980	—	10004
1.5	1490	L4	1981	1985	—	10018
1.6	1597	L4	1986	1986	—	10018
1.6	1597	L4	1987	1987	From 7/87	07079
1.6	1597	L4	1987	1987	To 6/87	10018
1.6	1597	L4	1988	1989	—	07079
1.6	1597	L4	1988	1989	Turbo	10029
1.6	1597	L4	1990	1994	—	10043
5						
2.3	2260	L4	2006	2010	—	MZK1003
2.5	2488	L4	2012	2014	Sold As Kit Only	MZK1015
6						
2.3	2260	L4	2003	2006	Sold As Kit Only	MZK1000
2.3	2260	L4	2007	2008	Sold As Kit Only	MZK1000
2.5	2488	L4	2009	2011	Sold As Kit Only	MZK1008
2.5	2488	L4	2012	2013	Sold As Kit Only	MZK1008
3.0	2968	V6	2003	2008	Sold As Kit Only	MZK1001
616						
1.6	1586	L4	1971	1971	—	10011
618						
1.8	1796	L4	1972	1972	—	10010
626, MX-6						
2.0	1970	L4	1979	1980	Non-Turbo	10005
2.0	1970	L4	1981	1981	Non-Turbo	10005
2.0	1970	L4	1982	1982	8-1/2" Disc, Non-Turbo	10005
2.0	1970	L4	1982	1982	8-7/8" Disc, Non-Turbo	10029
2.0	1970	L4	1983	1983	Non-Turbo	10029
2.0	1998	L4	1984	1985	Diesel	10029
2.0	1998	L4	1984	1986	Non-Turbo	10029
2.0	1998	L4	1986	1987	Turbo	10015
2.0	1991	L4	1993	2002	—	07094
2.2	2184	L4	1988	1992	Heavy Duty, Ductile Iron Cover	10029D
2.2	2184	L4	1988	1992	Non-Turbo	10029
2.2	2184	L4	1988	1992	Turbo with ABS	07067
2.2	2184	L4	1988	1992	Turbo without ABS	07067
2.2	2184	L4	1991	1991	Non-Turbo 8-7/8 Disc	10029
2.5	2497	V6	1993	2002	—	07095
808						
1.6	1587	L4	1972	1973	—	10011
1.6	1587	L4	1974	1977	—	10011
929						
3.0	2954	V6	1988	1988	—	10032
COSMO						
1.3	1308	R2	1976	1978	—	07021

EXEDY OEM	Disc (mm)	Disc (in)	Spline Dia	Splines	Master Cylinder	Slave Cylinder	Clutch Cable	Clutch Fork	New Flywheel
—	238	9-3/8	1-1/8	10	—	—	—	—	—
—	225	8-7/8	15/16	22	—	—	—	—	—
—	225	8-7/8	31/32	22	—	—	—	—	—
—	230	9-1/16	1	23	—	—	—	—	—
—	225	8-7/8	31/32	22	—	—	—	—	MZF503
—	230	9-1/16	15/16	22	—	—	—	—	—
Y	184	7-1/4	7/8	20	—	—	—	—	—
Y	184	7-1/4	7/8	20	—	—	—	—	—
Y	190	7-1/2	7/8	20	—	—	—	—	—
Y	190	7-1/2	7/8	20	—	—	CC606	—	—
Y	190	7-1/2	7/8	20	—	—	CC606	—	—
Y	190	7-1/2	7/8	20	—	—	CC606	—	—
Y	190	7-1/2	7/8	20	MC494	SC609	CC606	—	—
Y	225	8-7/8	15/16	22	MC494	SC609	—	—	—
—	190	7-1/2	7/8	20	MC221	SC628	—	—	—
—	225	8-7/8	31/32	22	—	—	—	—	MZF503
Y	230	9-1/16	31/32	22	—	—	—	—	—
Y	215	8-1/2	15/16	22	MC221	SC877	—	—	—
Y	215	8-1/2	15/16	22	MC221	—	—	—	—
Y	230	9-1/16	15/16	22	—	—	—	—	FMF536
Y	230	9-1/16	15/16	22	—	—	—	—	—
Y	240	9-1/2	1-1/16	23	MC221	SC877	—	—	—
Y	200	7-7/8	15/16	22	—	—	—	—	—
Y	215	8-1/2	15/16	22	—	—	—	—	—
Y	215	8-1/2	15/16	22	MC203	SC623	—	—	—
Y	215	8-1/2	15/16	22	MC206	SC624	—	—	—
Y	215	8-1/2	15/16	22	MC206	SC624	—	—	—
Y	225	8-7/8	15/16	22	MC206	SC816	CC607	—	—
Y	225	8-7/8	15/16	22	—	—	CC607	—	—
Y	225	8-7/8	15/16	22	—	—	CC607	—	—
Y	225	8-7/8	15/16	22	—	—	CC607	—	FMF512
Y	225	8-7/8	15/16	22	—	—	CC607	—	FMF512
Y	215	8-1/2	15/16	22	MC213	SC630	—	—	—
Y	225	8-7/8	15/16	22	MC211	SC606	—	—	FMF512
Y	225	8-7/8	15/16	22	MC211	SC606	—	—	FMF512
Y	240	9-1/2	1-1/16	23	MC212	SC607	—	—	—
Y	240	9-1/2	1-1/16	23	MC211	SC607	—	—	—
Y	225	8-7/8	15/16	22	MC211	SC606	—	—	FMF512
Y	225	8-7/8	15/16	22	MC213	SC630	—	—	—
Y	200	7-7/8	15/16	22	MC479	—	—	—	—
Y	200	7-7/8	15/16	22	MC479	SC623	—	—	—
Y	240	9-1/2	1-1/16	23	—	SC828	—	—	—
Y	215	8-1/2	15/16	22	MC203	—	—	—	—

Liter	CC/IN	Cyl	Years		Application Information	Kit
			To	From		
MAZDA (Performance Applications Available) continued						
<i>MIATA, MX-5 MIATA</i>						
1.6	1597	L4	1990	1993	—	10036
1.8	1839	L4	1994	2005	—	KMZ03
2.0	2000	L4	2006	2014	5spd, Sold as Kit Only	MZK1005
2.0	2000	L4	2006	2015	6spd, Sold as Kit Only	MZK1006
2.0	2000	L4	2016	2018	—	MZK1017
<i>MIZER</i>						
1.3	1272	L4	1976	1977	—	KMZ05
<i>MX-3</i>						
1.6	1597	L4	1992	1993	—	10043
1.6	1597	L4	1994	1995	—	KMZ04
1.8	1845	V6	1992	1994	—	KMZ02
<i>PROTEGE</i>						
1.5	1489	L4	1995	1998	—	KMZ04
1.6	1589	L4	1999	2001	—	KMZ04
1.8	1839	L4	1990	1991	4 WD	07074
1.8	1839	L4	1990	1995	2 WD	10040
1.8	1839	L4	1996	1998	—	10040
1.8	1839	L4	1999	2000	—	KMZ04
2.0	2000	L4	2001	2003	—	KMZ08
<i>R100</i>						
1.1	1146	R2	1971	1972	—	KMZ07
<i>RX-2</i>						
1.1	1146	R2	1971	1974	—	07021
<i>RX-3</i>						
1.1	1146	R2	1972	1978	—	07021
<i>RX-4</i>						
1.3	1308	R2	1974	1978	—	07021
<i>RX-7</i>						
1.1	1146	R2	1979	1979	To 3/79	07020
1.1	1146	R2	1979	1982	From 4/79	07020
1.1	1146	R2	1983	1983	—	10025
1.1	1146	R2	1984	1985	—	10025
1.3	1308	R2	1984	1988	Non-Turbo	10025
1.3	1308	R2	1987	1988	Turbo	07067
1.3	1308	R2	1989	1991	Non-Turbo	10038
1.3	1308	R2	1989	1991	Turbo, Sold As Kit Only	10037
1.3	1308	R2	1993	1995	Turbo, Sold As Kit Only, Pull Type	KMZ01
<i>RX-8</i>						
1.3	1308	R2	2003	2005	Sold As Kit Only	MZK1002
1.3	1308	R2	2006	2008	Sold As Kit Only, WAD Style Patented Disc	MZK1007
1.3	1308	R2	2009	2012	Sold As Kit Only	MZK1014
MAZDA LIGHT TRUCK, SUV & VAN						
<i>B1600</i>						
1.6	1586	L4	1972	1975	—	10011
1.6	1586	L4	1976	1976	—	10011
<i>B1800</i>						
1.8	1796	L4	1977	1978	—	07021
<i>B2000</i>						
2.0	1970	L4	1979	1979	—	07020
2.0	1970	L4	1980	1984	—	07020
2.0	1998	L4	1986	1987	—	10029
<i>B2200</i>						
2.2	2209	L4	1982	1984	Diesel	10025
2.2	2184	L4	1987	1993	—	10029

2

EXEDY OEM	Disc (mm)	Disc (in)	Spline Dia	Splines	Master Cylinder	Slave Cylinder	Clutch Cable	Clutch Fork	New Flywheel
Y	200	7-7/8	15/16	22	MC229	SC825	—	—	—
Y	215	8-1/2	15/16	22	MC229	SC825	—	—	—
Y	215	8-1/2	31/32	22	MC575	SC908	—	—	—
Y	215	8-1/2	1-1/32	23	MC575	SC908	—	—	—
—	215	8-1/2	15/16	22	—	—	—	—	—
Y	184	7-1/4	7/8	20	MC479	SC812	—	—	—
—	190	7-1/2	7/8	20	MC221	SC628	—	—	—
Y	200	7-7/8	7/8	20	MC221	SC628	—	—	—
Y	225	8-7/8	15/16	22	MC221	SC630	—	—	—
Y	200	7-7/8	7/8	20	MC221	SC628	—	—	—
Y	200	7-7/8	7/8	20	MC213	SC628	—	—	—
Y	215	8-7/16	15/16	22	MC221	SC629	—	—	—
Y	200	7-7/8	7/8	20	MC221	SC628	—	—	—
Y	200	7-7/8	7/8	20	MC221	SC628	—	—	—
Y	200	7-7/8	7/8	20	MC213	SC860	—	—	—
Y	225	8-7/8	15/16	22	MC213	—	—	—	—
Y	200	7-7/8	13/16	13	—	—	—	—	—
Y	215	8-1/2	15/16	22	—	—	—	—	—
Y	215	8-1/2	15/16	22	MC479	—	—	—	—
Y	215	8-1/2	15/16	22	MC203	—	—	—	—
Y	215	8-1/2	15/16	22	MC203	—	—	—	—
Y	215	8-1/2	15/16	22	MC205	SC611	—	—	—
Y	225	8-7/8	15/16	22	MC205	SC612	—	—	—
Y	225	8-7/8	15/16	22	MC207	SC612	—	—	—
Y	225	8-7/8	15/16	22	MC210	SC611	—	—	—
Y	240	9-1/2	1-1/16	23	MC210	SC614	—	—	—
Y	225	8-7/8	15/16	22	MC210	SC613	—	—	—
Y	230	9-1/16	1-1/16	23	MC210	SC614	—	—	—
Y	237	9-5/16	1-1/16	23	MC495	—	—	—	—
Y	236	9-1/4	1-1/32	23	MC487	—	—	—	—
Y	236	9-1/4	1-1/32	23	MC487	—	—	—	—
Y	236	9-1/4	1-1/32	23	—	—	—	—	—
Y	200	7-7/8	15/16	22	MC477	—	—	—	—
Y	200	7-7/8	15/16	22	MC480	SC623	—	—	—
Y	215	8-1/2	15/16	22	MC203	SC623	—	—	—
Y	215	8-1/2	15/16	22	—	SC623	—	—	—
Y	215	8-1/2	15/16	22	MC219	SC623	—	—	—
Y	225	8-7/8	15/16	22	MC202	SC620	—	—	FMF512
Y	225	8-7/8	15/16	22	MC219	SC618	—	—	—
Y	225	8-7/8	15/16	22	MC202	SC620	—	—	FMF512

2

Liter	CC/IN	Cyl	Years		Application Information	Kit
			To	From		
MAZDA LIGHT TRUCK, SUV & VAN continued						
B2300						
2.3	2295	L4	1994	1994	—	07093
2.3	2295	L4	1995	2006	Self Adjusting Clutch	KFM30
2.3	2294	L4	1995	2006	Non Self Adjusting Clutch, Economy EXEDY version	KFM07
B2500						
2.5	2492	L4	1998	2001	Non Self Adjusting Clutch, Economy EXEDY version	KFM07
2.5	2492	L4	1998	2001	Self Adjusting Clutch	KFM30
B2600						
2.6	2555	L4	1987	1988	Carbureted	07067
2.6	2606	L4	1989	1993	Fuel Injected	10042
B3000						
3.0	2983	V6	1994	1994	To Oct 31/1998	07099
3.0	2983	V6	1995	2006	Non Self Adjusting Clutch, Economy EXEDY version	KFM06
3.0	2983	V6	1995	2006	Self Adjusting Clutch	KFM30
B4000						
4.0	4016	V6	1994	1998	—	07096
4.0	4016	V6	1999	2000	Self Adjusting Clutch	07139
4.0	4016	V6	2001	2008	Self Adjusting Clutch	FMK1000
CX-5						
2.0	1998	L4	2012	2014	—	MZK1016
MPV						
2.6	2606	L4	1989	1991	—	10034
3.0	2954	V6	1989	1991	—	10034
NAVAJO						
4.0	4016	V6	1991	1991	—	07077
4.0	4016	V6	1992	1992	From 4/92	07077
4.0	4016	V6	1992	1992	To 3/92	07077
4.0	4016	V6	1993	1994	—	07096
TRIBUTE						
2.0	1991	L4	2001	2004	—	KFM16
2.3	2299	L4	2005	2008	Sold as Kit Only, Includes CSC Hydraulic Slave Cylinder	FMK1019
MERCEDES-BENZ						
190 SERIES						
2.2	2197	L4	1984	1985	Diesel, Sold As Kit Only	KME02
2.3	2299	L4	1984	1987	8 Valve	11005
2.3	2299	L4	1986	1987	16 Valve	11007
2.3	2299	L4	1988	1988	—	11009
2.3	2299	L4	1991	1993	Sold As Kit Only	KME01
2.5	2497	L5	1986	1989	Diesel	11008
2.6	2599	L6	1987	1989	—	11009
2.6	2599	L6	1990	1990	From Chassis # F640695, Sold As Kit Only	KME01
2.6	2599	L6	1990	1990	To Chassis # F640694	11009
2.6	2599	L6	1991	1993	Sold As Kit Only	KME01
C230						
1.8	1796	L4	2003	2003	Includes Slave Cylinder, Sold As Kit Only	KME03
1.8	1796	L4	2004	2004	Sold as Kit Only, Includes CSC Hydraulic Slave Cylinder	BZK1000
1.8	1796	L4	2005	2005	Sold as Kit Only, Includes CSC Hydraulic Slave Cylinder	BZK1002
2.5	2496	V6	2006	2007	Sold as Kit Only, Includes CSC Hydraulic Slave Cylinder	BZK1002
C240 SERIES						
2.6	2597	V6	2001	2003	Includes Slave Cylinder, Sold As Kit Only	KME03
3.2	3199	V6	2003	2003	Includes Slave Cylinder, Sold As Kit Only	KME03
3.2	3199	V6	2004	2005	Sold as Kit Only, Includes CSC Hydraulic Slave Cylinder	BZK1003
SLK230						
2.3	2295	L4	2001	2003	Sold as Kit Only	BZK1005
2.3	2295	L4	2004	2004	Sold as Kit Only, Includes CSC Hydraulic Slave Cylinder	BZK1001

EXEDY OEM	Disc (mm)	Disc (in)	Spline Dia	Splines	Master Cylinder	Slave Cylinder	Clutch Cable	Clutch Fork	New Flywheel
Y	225	8-7/8	1	23	MC365	SC778	—	—	—
—	225	8-7/8	1	23	MC367	SC778	—	—	—
—	225	8-7/8	1	23	MC367	SC778	—	—	—
—	225	8-7/8	1	23	MC367	SC778	—	—	—
—	225	8-7/8	1	23	MC367	SC778	—	—	—
Y	240	9-1/2	1-1/16	23	MC202	SC624	—	—	—
Y	250	9-7/8	1-1/16	23	MC202	SC626	—	—	—
—	225	8-7/8	1	23	MC364	SC778	—	—	FMF508
—	228	9	1	23	MC367	SC778	—	—	FMF507
—	228	9	1	23	MC367	SC778	—	—	FMF507
—	254	10	1-1/16	23	MC367	SC778	—	—	—
—	257	10-1/8	1-1/16	23	MC367	SC778	—	—	—
—	257	10-1/8	1	23	MC367	SC778	—	—	—
Y	230	9-1/16	1	23	—	—	—	—	—
Y	250	9-7/8	1-1/16	23	MC220	SC622	—	—	—
Y	250	9-7/8	1-1/16	23	MC220	SC625	—	—	—
—	254	10	1-1/16	23	MC353	SC783	—	—	—
—	254	10	1-1/16	23	MC364	SC783	—	—	—
—	254	10	1-1/16	23	MC359	SC783	—	—	—
—	254	10	1-1/16	23	MC364	SC778	—	—	—
—	225	8-7/8	15/16	22	MC370	SC740	—	—	—
—	240	9-7/16	1	23	—	—	—	—	—
—	203	8	1-1/8	26	—	—	—	—	—
—	215	8-1/2	1-1/16	26	—	—	—	—	—
—	211	8-5/16	1-1/8	26	—	—	—	—	—
—	215	8-1/2	1-1/8	24	—	—	—	—	—
—	228	9	1-1/8	26	—	—	—	—	—
—	215	8-1/2	1-1/16	26	—	—	—	—	—
—	215	8-1/2	1-1/8	24	—	—	—	—	—
—	228	9	1-1/8	26	—	—	—	—	—
—	215	8-1/2	1-1/8	24	—	—	—	—	—
—	228	9	1-1/8	26	—	—	—	—	—
—	232	9-1/8	1-1/8	26	—	—	—	—	—
—	240	9-7/16	1-1/16	26	—	—	—	—	—
—	228	9	1-1/16	26	—	—	—	—	—
—	228	9	1-1/16	26	—	—	—	—	—
—	232	9-1/8	1-1/8	26	—	—	—	—	—
—	232	9-1/8	1-1/8	26	—	—	—	—	—
—	240	9-7/16	1-1/16	26	—	—	—	—	—
—	228	9	1 1/16	26	—	—	—	—	—
—	228	9	1-1/16	26	—	—	—	—	—

Liter	CC/IN	Cyl	Years		Application Information	Kit
			To	From		
MERCEDES-BENZ continued						
<i>SLK280</i>						
3.0	2996	V6	2006	2008	Sold as Kit Only	BZK1004
<i>SLK320</i>						
3.2	3199	V6	2001	2004	Sold as Kit Only, Includes CSC Hydraulic Slave Cylinder	CRK1009
<i>SLK350</i>						
3.5	3498	V6	2005	2008	Sold as Kit Only	BZK1004
MERCURY						
<i>BOBCAT</i>						
2.3	140	L4	1975	1980	—	07003
<i>CALIENTE, CYCLONE, MARQUIS, MONTCLAIR, MONTEREY, PARK LANE</i>						
4.3	262	V8	1964	1964	—	07014
5.0	302	V8	1968	1970	—	07014
5.8	354	V8	1971	1972	Diaph Clutch	KFM10
5.8	354	V8	1971	1972	Lever Clutch	07027L
6.4	391	V8	1962	1970	Diaph Clutch	KFM10
6.4	391	V8	1962	1970	Lever Clutch	07027L
<i>CAPRI</i>						
1.6	98	L4	1991	1994	Non-Turbo	10040
1.6	98	L4	1991	1994	Turbo	10029
2.3	140	L4	1976	1977	Ford 4 Spd, Non-Turbo, 10 Spline Disc	07006
2.3	140	L4	1979	1979	Turbo	07006
2.3	140	L4	1979	1986	Non-Turbo, 4 Spd, 23 Spline Disc	07003
2.3	140	L4	1980	1983	Ford 4 Spd, Non-Turbo, 10 Spline Disc	07030
2.3	140	L4	1981	1981	5 Spd, Non-Turbo, 10 Spline Disc, 10/1/80-11/30/80	07006
2.3	140	L4	1981	1983	5 Spd, Non-Turbo, 23 Spline Disc, From 12/1/80	07029
2.3	140	L4	1982	1983	Turbo	07006
2.3	140	L4	1983	1985	5 Spd, 10 Spline Disc	07038
2.3	140	L4	1986	1986	3 Spd, 10 Spline Disc	07038
3.3	201	L6	1979	1982	—	07003
5.0	302	V8	1979	1979	—	07005
5.0	302	V8	1982	1985	—	07005
5.0	302	V8	1986	1986	Heavy Duty, Sold As Kit Only	KFM08HP
5.0	302	V8	1986	1986	Standard	07042
<i>COMET</i>						
4.1	250	L6	1974	1977	—	07016
4.3	262	V8	1963	1964	—	07014
4.7	287	V8	1966	1967	—	07014
5.0	302	V8	1968	1969	—	07014
5.0	302	V8	1971	1974	—	07014
5.0	302	V8	1975	1977	—	07016
5.8	354	V8	1969	1969	Diaph Clutch	KFM10
5.8	354	V8	1969	1969	Heavy Duty Diaph Clutch	KFM10HP
5.8	354	V8	1969	1969	Lever Clutch	07027L
6.4	391	V8	1966	1969	Diaph Clutch	KFM10
6.4	391	V8	1966	1969	Heavy Duty Diaph Clutch	KFM10HP
6.4	391	V8	1966	1969	Lever Clutch	07027L
<i>COUGAR</i>						
2.0	122	L4	1999	2002	Includes Slave Cylinder	07136
2.3	140	L4	1985	1986	Turbo	07038
2.5	153	V6	1999	2002	Includes Slave Cylinder	07137
2.5	153	V6	1999	2002	Kit does not include Slave Cylinder	07137LB
4.7	287	V8	1967	1968	—	07014
5.0	302	V8	1968	1970	—	07014
5.8	354	V8	1969	1973	Diaph Clutch with External Balance Flywheel	KFM10
5.8	354	V8	1969	1973	Heavy Duty Diaph Clutch with External Balance Flywheel	KFM10HP

2

EXEDY OEM	Disc (mm)	Disc (in)	Spline Dia	Splines	Master Cylinder	Slave Cylinder	Clutch Cable	Clutch Fork	New Flywheel
—	239	9 3/8	1 1/8	26	—	—	—	—	—
—	240	9-7/16	1-1/8	26	—	—	—	—	—
—	239	9 3/8	1 1/8	26	—	—	—	—	—
—	215	8-1/2	1-1/32	23	—	—	—	—	—
—	254	10	1-1/16	10	—	—	—	—	—
—	254	10	1-1/16	10	—	—	—	—	—
—	280	11	1-1/16	10	—	—	—	—	—
—	280	11	1-1/16	10	—	—	—	—	—
—	280	11	1-1/16	10	—	—	—	—	—
—	280	11	1-1/16	10	—	—	—	—	—
Y	200	7-7/8	7/8	20	—	SC607	—	—	—
Y	225	8-7/8	15/16	22	—	—	—	—	—
—	215	8-7/16	1-1/16	10	—	—	—	—	—
—	215	8-7/16	1-1/16	10	—	—	—	—	—
—	215	8-1/2	1-1/32	23	—	—	—	—	—
—	215	8-7/16	1-1/16	10	—	—	—	—	—
—	215	8-7/16	1-1/16	10	—	—	—	—	—
—	215	8-1/2	1-1/16	23	—	—	—	—	—
—	215	8-7/16	1-1/16	10	—	—	—	—	—
Y	225	8-7/8	1-1/16	10	—	—	CC315	—	—
Y	225	8-7/8	1-1/16	10	—	—	CC315	—	—
—	215	8-1/2	1-1/32	23	—	—	—	—	—
—	254	10	1-1/16	10	—	—	—	—	—
—	254	10	1-1/16	10	—	—	CC318	—	—
—	265	10-1/2	1-1/16	10	—	—	CC318	—	FWFM112/FMF500
—	265	10-1/2	1-1/16	10	—	—	CC318	—	FWFM112/FMF500
—	254	10	1-1/16	10	—	—	—	—	—
—	254	10	1-1/16	10	—	—	—	—	—
—	254	10	1-1/16	10	—	—	—	—	—
—	254	10	1-1/16	10	—	—	—	—	—
—	254	10	1-1/16	10	—	—	—	—	—
—	254	10	1-1/16	10	—	—	—	—	—
—	280	11	1-1/16	10	—	—	—	—	FWFM113
—	280	11	1-1/16	10	—	—	—	—	FWFM113
—	280	11	1-1/16	10	—	—	—	—	FWFM113
—	280	11	1-1/16	10	—	—	—	—	FWFM113
—	280	11	1-1/16	10	—	—	—	—	FWFM113
—	240	9-1/2	1	23	MC119	—	—	—	—
Y	225	8-7/8	1-1/16	10	—	—	CC315	—	—
—	240	9-1/2	1	23	MC119	—	—	—	—
—	240	9-1/2	1	23	MC119	—	—	—	—
—	254	10	1-1/16	10	—	—	—	—	—
—	254	10	1-1/16	10	—	—	—	—	—
—	280	11	1-1/16	10	—	—	—	—	FWFM116
—	280	11	1-1/16	10	—	—	—	—	FWFM116

2

Liter	CC/IN	Cyl	Years		Application Information	Kit
			To	From		
MERCURY continued						
<i>COUGAR</i>						
5.8	354	V8	1969	1973	Heavy Duty Diaph Clutch with Internal Balance Flywheel	KFM10HP
5.8	354	V8	1969	1973	Lever Clutch with Internal Balance Flywheel	07027L
6.4	391	V8	1967	1969	Diaph Clutch	KFM10
6.4	391	V8	1967	1969	Heavy Duty Diaph Clutch	KFM10HP
6.4	391	V8	1967	1969	Lever Clutch	07027L
<i>MILAN</i>						
2.3	140	L4	2006	2009	Sold As Kit Only	FMK1004
<i>MONARCH</i>						
4.1	250	L6	1975	1980	—	07016
5.0	302	V8	1977	1979	3 Spd	07016
<i>MONTEGO</i>						
4.1	250	L6	1969	1973	—	07014
5.0	302	V8	1969	1974	—	07014
5.8	354	V8	1969	1974	Diaph Clutch	KFM10
5.8	354	V8	1969	1974	Heavy Duty Diaph Clutch	KFM10HP
5.8	354	V8	1969	1974	Lever Clutch	07027L
6.4	391	V8	1968	1969	Diaph Clutch	KFM10
6.4	391	V8	1968	1969	Heavy Duty Diaph Clutch	KFM10HP
6.4	391	V8	1968	1969	Lever Clutch	07027L
<i>MYSTIQUE</i>						
2.0	122	L4	1995	2000	Includes Slave Cylinder	07136
2.5	153	V6	1995	2000	Includes Slave Cylinder	07137
2.5	153	V6	1995	2000	Kit does not include Slave Cylinder	07137LB
<i>TOPAZ</i>						
2.3	140	L4	1988	1994	—	07069
<i>TRACER</i>						
1.6	98	L4	1987	1989	—	10018
1.8	110	L4	1991	1996	—	07074
1.9	116	L4	1991	1996	—	07075
2.0	122	L4	1997	1997	—	07083
2.0	122	L4	1998	1998	—	07083
<i>ZEPHYR</i>						
2.3	140	L4	1978	1983	—	07003
3.3	201	L6	1978	1981	—	07003
5.0	302	V8	1978	1978	—	07016
5.0	302	V8	1979	1979	—	07005
MERKUR						
<i>SCORPIO</i>						
2.9	177	V6	1988	1989	—	07088
<i>XR4TI</i>						
2.3	140	L4	1985	1989	Turbo	07039
MG						
<i>MGB, MGB GT</i>						
1.8	1798	L4	1963	1980	Sold As Kit Only	KMG04
1.8	1798	L4	1981	1981	Sold As Kit Only	KMG04
MINI (Performance Applications Available)						
<i>COOPER</i>						
1.6	1600	L4	2002	2004	5 Spd, Sold As Kit Only	BMK1000
1.6	1600	L4	2005	2005	From 7/04, Sold as Kit Only	BMK1013
1.6	1600	L4	2006	2007	From 11/06, Sold as Kit Only	BMK1014
<i>COOPER S</i>						
1.6	1600	L4	2002	2008	6 Spd Supercharged, Sold as Kit Only, Fits Dual Mass FW	BMK1001
1.6	1600	L4	2002	2008	6 Spd Supercharged, Solid FW Conversion, Sold as Kit Only, Includes Solid FW	BMK1001FW

2

EXEDY OEM	Disc (mm)	Disc (in)	Spline Dia	Splines	Master Cylinder	Slave Cylinder	Clutch Cable	Clutch Fork	New Flywheel
—	280	11	1-1/16	10	—	—	—	—	FWFM113
—	280	11	1-1/16	10	—	—	—	—	FWFM113
—	280	11	1-1/16	10	—	—	—	—	FWFM113
—	280	11	1-1/16	10	—	—	—	—	FWFM113
—	280	11	1-1/16	10	—	—	—	—	FWFM113
Y	225	8-7/8	15/16	22	MC221	SC877	—	—	—
—	254	10	1-1/16	10	—	—	—	—	—
—	254	10	1-1/16	10	—	—	—	—	—
—	254	10	1-1/16	10	—	—	—	—	—
—	254	10	1-1/16	10	—	—	—	—	—
—	280	11	1-1/16	10	—	—	—	—	FWFM113
—	280	11	1-1/16	10	—	—	—	—	FWFM113
—	280	11	1-1/16	10	—	—	—	—	FWFM113
—	280	11	1-1/16	10	—	—	—	—	FWFM113
—	280	11	1-1/16	10	—	—	—	—	FWFM113
—	280	11	1-1/16	10	—	—	—	—	FWFM113
—	240	9-1/2	1	23	MC119	—	—	—	—
—	240	9-1/2	1	23	—	—	—	—	FWFMC01
—	240	9-1/2	1	23	—	—	—	—	FWFMC01
—	215	8-7/16	7/8	20	—	—	—	—	—
Y	190	7-1/2	7/8	20	—	—	—	—	—
Y	215	8-7/16	15/16	22	MC221	SC629	—	—	—
Y	200	7-7/8	7/8	20	MC221	SC839	—	—	—
Y	225	8-7/8	15/16	22	MC221	SC877	—	—	—
Y	225	8-7/8	15/16	22	MC221	—	—	—	—
—	215	8-1/2	1-1/32	23	—	—	—	—	—
—	215	8-1/2	1-1/32	23	—	—	—	—	—
—	254	10	1-1/16	10	—	—	—	—	—
—	254	10	1-1/16	10	—	—	—	—	—
—	240	9-1/2	1	23	—	—	—	—	—
—	228	9	1	23	—	—	—	—	—
—	200	7-7/8	1	23	MC491	SC888	—	—	—
—	200	7-7/8	1	23	—	—	—	—	—
—	200	7-7/8	13/16	18	—	—	—	—	—
—	200	7-7/8	13/16	17	—	—	—	—	—
—	200	7-7/8	3/4	17	—	—	—	—	—
—	215	8-1/2	1	14	—	—	—	—	—
—	215	8-1/2	1	14	—	—	—	—	—

Liter	CC/IN	Cyl	Years		Application Information	Kit
			To	From		
MITSUBISHI (Performance Applications Available)						
3000GT						
3.0	2972	V6	1991	1991	Turbo, 1/1/91 - 1/31/91, Sold As Kit Only	05075
3.0	2972	V6	1991	1999	Non-Turbo, Sold As Kit Only	05048
3.0	2972	V6	1992	1999	Turbo, Sold As Kit Only	05075
CORDIA, TREDIA						
1.8	1795	L4	1983	1983	—	05026
1.8	1795	L4	1984	1988	Turbo	05026
2.0	1997	L4	1984	1988	—	05026
ECLIPSE						
1.8	1755	L4	1990	1990	Without Speed Control	05026
1.8	1755	L4	1990	1994	With Speed Control	05026
2.0	1997	L4	1990	1990	2 WD Non-Turbo without Speed Control	05051
2.0	1997	L4	1990	1990	2 WD, GS Turbo without Speed Control, Sold As Kit Only	05048
2.0	1997	L4	1990	1992	4 WD, Turbo GSX	05071
2.0	1997	L4	1990	1994	2 WD Non-Turbo with Speed Control	05051
2.0	1997	L4	1990	1994	2 WD, GS Turbo with Speed Control, Sold As Kit Only	05048
2.0	1997	L4	1993	1993	4 WD, Turbo GSX, Sold As Kit Only	05048
2.0	1997	L4	1994	1999	4 WD, Turbo GSX, Sold As Kit Only	05048
2.0	1997	L4	1995	1998	GST, Sold As Kit Only	05048
2.0	1997	L4	1995	1999	2 WD, Non-Turbo, Modular Clutch Includes Flywheel	05085
2.4	2351	L4	1996	1999	Sold As Kit Only	05048
2.4	2351	L4	2000	2005	Sold As Kit Only	MBK1000
2.4	2378	L4	2006	2012	Sold as Kit Only	MBK1010
3.0	2972	V6	2000	2005	Sold As Kit Only, Silent Design Disc, Pull Type, Flat Flywheel, GT	KMB02
3.0	2972	V6	2003	2005	GTS, Sold As Kit Only, Silent Design Disc, Pull Type, Flat Flywheel, Sold As Kit Only	MBK1003
3.8	232	V6	2006	2010	Sold as Kit Only, Includes CSC Hydraulic Slave Cylinder	MBK1015
GALANT						
2.0	1997	L4	1989	1989	GS SOHC	05051
2.0	1997	L4	1989	1992	—	05051
2.0	1997	L4	1990	1991	GSX DOHC AWD	05051
2.0	1997	L4	1990	1992	GS, GSR DOHC	05071
2.0	1997	L4	1991	1992	VR4 AWD Turbo, Sold As Kit Only	05048
2.0	1997	L4	1992	1992	GSX DOHC AWD	05071
2.0	1997	L4	1993	1993	LS SOHC	05051
2.4	2351	L4	1987	1987	—	05056
2.4	2351	L4	1994	1998	Sold As Kit Only	05048
LANCER						
2.0	2000	L4	2002	2003	Does not include Hydraulic CSC, Sold As Kit Only	MBK1004LB
2.0	2000	L4	2002	2003	Includes Slave Cylinder, Sold As Kit Only	MBK1004
2.0	2000	L4	2003	2006	Turbo Evolution, Sold As Kit Only, Pull Type	MBK1001
2.0	2000	L4	2004	2006	Sold as kit only	MBK1008
2.0	1998	L4	2008	2015	Sold as Kit Only, Includes CSC Hydraulic Slave Cylinder	MBK1011
2.0	1998	L4	2008	2015	Turbo Evolution, Sold As Kit Only	MBK1009
2.4	2400	L4	2004	2006	Sold as kit only	MBK1007
2.4	2400	L4	2009	2015	Sold as Kit Only, Includes CSC Hydraulic Slave Cylinder	MBK1018
MIRAGE						
1.5	1468	L4	1985	1987	4 Spd, To 3/31/88	05022
1.5	1468	L4	1985	1987	5 Spd, To 3/31/88	05023
1.5	1468	L4	1988	1988	5 Spd, To 3/31/88	05023
1.5	1468	L4	1988	1991	4 Spd, To 3/31/88	05022
1.5	1468	L4	1989	1992	5 Spd	05026
1.5	1468	L4	1993	1996	5 Spd	05026
1.5	1468	L4	1997	2002	5 Spd	05026
1.6	1597	L4	1985	1987	5 Spd Turbo	05022
1.6	1597	L4	1988	1988	5 Spd Turbo, To 3/31/88	05022
1.6	1597	L4	1988	1989	5 Spd Turbo, From 4/1/86	05051
1.6	1597	L4	1991	1992	—	05022
1.8	1834	L4	1993	1996	—	05051
1.8	1834	L4	1997	2002	—	05051

EXEDY OEM	Disc (mm)	Disc (in)	Spline Dia	Splines	Master Cylinder	Slave Cylinder	Clutch Cable	Clutch Fork	New Flywheel
—	250	9-7/8	1	23	MC544	SC582	—	—	—
Y	225	8-7/8	7/8	20	MC543	SC837	—	—	—
—	250	9-7/8	1	23	MC544	SC588	—	—	—
Y	200	7-7/8	7/8	20	MC194	—	—	—	—
Y	200	7-7/8	7/8	20	MC194	SC582	—	—	—
Y	200	7-7/8	7/8	20	MC194	—	—	—	—
Y	200	7-7/8	7/8	20	MC529	SC580	—	—	—
Y	200	7-7/8	7/8	20	MC180	SC581	—	—	—
Y	215	8-1/2	7/8	20	MC529	SC580	—	—	—
Y	225	8-7/8	7/8	20	MC529	SC820	—	—	—
Y	225	8-7/8	7/8	20	MC180	SC587	—	—	—
Y	215	8-1/2	7/8	20	MC180	SC581	—	—	—
Y	225	8-7/8	7/8	20	MC180	SC581	—	—	—
Y	225	8-7/8	7/8	20	MC180	SC587	—	—	—
Y	225	8-7/8	7/8	20	MC188	SC589	—	—	—
Y	225	8-7/8	7/8	20	MC401	SC581	—	—	—
—	230	9-1/16	15/16	17	MC401	SC761	—	—	—
Y	225	8-7/8	7/8	20	MC188	SC589	—	—	MBF501
Y	225	8-7/8	7/8	20	MC565	SC593	—	—	MBF500
Y	230	9	7/8	20	—	SC593	—	—	MBF500
Y	225	8-7/8	1	23	MC564	SC854	—	—	MBF508
Y	232	9-1/16	1	23	MC564	SC854	—	—	—
—	240	9-7/16	1	23	—	BRG0162	—	—	—
Y	215	8-1/2	7/8	20	MC179	SC581	—	—	—
Y	215	8-1/2	7/8	20	MC529	SC580	—	—	—
Y	215	8-1/2	7/8	20	MC179	SC584	—	—	—
Y	225	8-7/8	7/8	20	MC179	SC581	—	—	—
Y	225	8-7/8	7/8	20	MC179	SC584	—	—	—
Y	225	8-7/8	7/8	20	MC179	SC584	—	—	—
Y	215	8-1/2	7/8	20	MC529	SC580	—	—	—
Y	225	8-7/8	7/8	20	MC177	SC580	—	—	—
Y	225	8-7/8	7/8	20	MC536	SC589	—	—	MBF501
Y	215	8-1/2	7/8	20	MC520	—	—	—	—
Y	215	8-1/2	7/8	20	MC520	—	—	—	—
Y	240	9-1/2	1	23	MC520	SC854	—	—	—
Y	215	8-1/2	7/8	20	MC520	SC593	—	—	—
Y	225	8-7/8	7/8	20	—	—	—	—	—
Y	240	9-1/2	1	23	—	—	—	—	MBF504
Y	228	9	7/8	20	MC522	SC844	—	—	—
Y	230	9	7/8	20	—	BRG0162	—	—	—
Y	200	7-7/8	7/8	20	—	—	—	—	—
Y	184	7-1/4	7/8	20	—	—	—	—	—
Y	184	7-1/4	7/8	20	MC178	SC584	—	—	—
Y	200	7-7/8	7/8	20	MC178	SC580	—	—	—
Y	200	7-7/8	7/8	20	MC178	SC584	—	—	—
Y	200	7-7/8	7/8	20	MC193	SC589	—	—	—
Y	200	7-7/8	7/8	20	MC193	SC593	—	—	—
Y	200	7-7/8	7/8	20	MC194	SC580	—	—	—
Y	200	7-7/8	7/8	20	MC194	SC580	—	—	—
Y	215	8-1/2	7/8	20	MC178	SC581	—	—	—
Y	200	7-7/8	7/8	20	MC178	SC581	—	—	—
Y	215	8-1/2	7/8	20	MC178	SC589	—	—	—
Y	215	8-1/2	7/8	20	MC193	SC593	—	—	—

Liter	CC/IN	Cyl	Years		Application Information	Kit
			To	From		
MITSUBISHI (Performance Applications Available) continued						
<i>PRECIS</i>						
1.5	1468	L4	1987	1988	—	05023
1.5	1468	L4	1989	1989	From 7/1/89	05022
1.5	1468	L4	1989	1989	To 6/30/89	05023
1.5	1468	L4	1990	1994	—	05022
<i>SIGMA</i>						
3.0	2972	V6	1988	1988	—	05056
<i>STARION</i>						
2.6	2555	L4	1983	1987	Non Intercooled Turbo	05025
2.6	2555	L4	1985	1987	Intercooled Turbo, To 5/31/87	05046
2.6	2555	L4	1987	1989	Intercooled Turbo, From 6/1/87	05049
MITSUBISHI LIGHT TRUCK & SUV						
<i>EXPO, EXPO LRV</i>						
1.8	1834	L4	1992	1994	—	05051
2.4	2351	L4	1992	1992	Sold As Kit Only	05048
2.4	2351	L4	1993	1995	Sold As Kit Only	05048
<i>MIGHTY MAX</i>						
2.0	1997	L4	1983	1986	—	05011
2.0	1997	L4	1987	1989	—	05011
2.3	2346	L4	1983	1983	Turbo Diesel From 10/83	05025
2.3	2346	L4	1983	1983	Turbo Diesel To 9/83	05025
2.3	2346	L4	1984	1985	Turbo Diesel	05025
2.4	2351	L4	1990	1993	—	05041
2.4	2351	L4	1994	1996	—	05041
2.6	2555	L4	1983	1986	—	05025
2.6	2555	L4	1987	1989	—	05041
3.0	2972	V6	1990	1994	—	05050
<i>MONTERO, MONTERO SPORT</i>						
2.4	2351	L4	1997	1999	—	05041
2.6	2555	L4	1983	1985	—	05025
2.6	2555	L4	1986	1986	—	05046
2.6	2555	L4	1987	1989	—	05052
3.0	2972	V6	1989	1990	—	05050
3.0	2972	V6	1991	1991	From 10/91	05050
3.0	2972	V6	1991	1991	To 9/91	05050
3.0	2972	V6	1992	1996	—	05050
3.0	2972	V6	1997	1999	—	05050
3.5	3497	V6	1997	1997	—	05050
<i>OUTLANDER</i>						
2.4	2378	L4	2005	2005	Sold as kit only	MBK1007
2.4	2378	L4	2006	2006	—	MBK1014
NISSAN						
<i>1200</i>						
1.2	1171	L4	1971	1973	—	06016
<i>200SX</i>						
1.6	1597	L4	1995	1998	—	06040
1.8	1809	L4	1984	1987	Turbo	06028
2.0	1952	L4	1977	1978	—	06008
2.0	1952	L4	1979	1979	To 5/79	06008
2.0	1952	L4	1979	1981	From 6/79	06008
2.0	1974	L4	1984	1988	—	06037
2.0	1998	L4	1995	1998	—	KNS02
2.2	2187	L4	1982	1983	—	06004
3.0	2960	V6	1987	1988	—	06031

2

EXEDY OEM	Disc (mm)	Disc (in)	Spline Dia	Splines	Master Cylinder	Slave Cylinder	Clutch Cable	Clutch Fork	New Flywheel
Y	184	7-1/4	7/8	20	—	—	CC550	—	—
Y	200	7-7/8	7/8	20	MC178	SC580	—	—	—
Y	184	7-1/4	7/8	20	—	—	CC550	—	—
Y	200	7-7/8	7/8	20	MC178	SC580	—	—	—
Y	225	8-7/8	7/8	20	—	SC580	—	—	—
Y	225	8-7/8	1-1/32	23	MC175	SC579	—	—	—
Y	225	8-7/8	1-1/32	23	MC175	SC579	—	—	—
Y	240	9-1/2	1-1/16	23	MC175	SC579	—	—	—
Y	215	8-1/2	7/8	20	—	SC589	—	—	—
Y	225	8-7/8	7/8	20	—	SC584	—	—	—
Y	225	8-7/8	7/8	20	—	SC589	—	—	MBF501
Y	215	8-7/16	7/8	23	—	—	—	—	—
Y	215	8-7/16	7/8	23	—	—	CC815	—	—
Y	225	8-7/8	1-1/32	23	MC176	SC579	—	—	—
Y	225	8-7/8	1-1/32	23	MC194	SC579	—	—	—
Y	225	8-7/8	1-1/32	23	MC176	SC579	—	—	—
Y	225	8-7/8	1-1/32	23	—	—	CC815	—	—
Y	225	8-7/8	1-1/32	23	—	—	—	—	—
Y	225	8-7/8	1-1/32	23	—	—	CC815	—	—
Y	240	9-1/2	1-1/8	14	MC176	SC585	—	—	—
Y	225	8-7/8	1-1/32	23	MC505	SC579	—	—	—
Y	225	8-7/8	1-1/32	23	MC497	SC579	—	—	—
Y	225	8-7/8	1-1/32	23	MC194	SC579	—	—	—
Y	225	8-7/8	1-1/32	23	MC194	SC579	—	—	—
Y	240	9-1/2	1-1/8	14	MC194	SC585	—	—	—
Y	240	9-1/2	1-1/8	14	MC528	SC835	—	—	—
Y	240	9-1/2	1-1/8	14	MC497	SC585	—	—	—
Y	240	9-1/2	1-1/8	14	MC528	SC591	—	—	—
Y	240	9-1/2	1-1/8	14	MC505	SC591	—	—	—
Y	240	9-1/2	1-1/8	14	MC528	SC845	—	—	—
Y	228	9	7/8	20	MC522	SC593	—	—	—
Y	228	9	7/8	20	MC522	SC593	—	—	—
—	184	7-1/4	13/16	18	—	SC558	—	—	—
Y	190	7-1/2	13/16	18	—	—	—	—	NSF501
Y	225	8-7/8	1	24	MC167	SC560	—	—	—
Y	200	7-7/8	1	24	MC152	SC560	—	—	—
Y	200	7-7/8	1	24	MC153	SC560	—	—	—
Y	200	7-7/8	1	24	MC152	SC560	—	CF114	—
Y	225	8-7/8	1	24	MC167	SC560	—	—	—
Y	215	8-1/2	13/16	18	—	—	—	—	NSF504
Y	225	8-7/8	1	24	MC153	SC560	—	—	—
Y	240	9-1/2	1	24	MC153	SC572	—	—	—

2

Liter	CC/IN	Cyl	Years		Application Information	Kit
			To	From		
NISSAN continued						
210						
1.2	1237	L4	1979	1982	—	06001
1.4	1393	L4	1979	1982	—	06001
1.5	1488	L4	1980	1982	—	06001
240SX						
2.4	2389	L4	1989	1990	—	06009
2.4	2389	L4	1991	1998	—	06054
240Z						
2.4	2393	L6	1970	1972	To 6/72	06029
2.4	2393	L6	1972	1972	From 7/72	06029
2.4	2393	L6	1973	1973	—	06029
260Z						
2.6	2565	L6	1974	1975	—	06029
280Z						
2.8	2753	L6	1975	1975	2 Seater To 3/75	06009
2.8	2753	L6	1975	1978	2 Seater From 4/75	06009
2.8	2753	L6	1975	1975	2+2 To 3/75	06030
2.8	2753	L6	1975	1978	2+2 From 4/75	06030
280ZX						
2.8	2753	L6	1979	1983	2 Seater Non-Turbo	06009
2.8	2753	L6	1979	1983	2+2 Non-Turbo	06030
2.8	2753	L6	1981	1983	Turbo	06032
300ZX						
3.0	2960	V6	1984	1989	Non-Turbo To 1/30/89	06031
3.0	2960	V6	1984	1986	Turbo	06032
3.0	2960	V6	1987	1989	Turbo	06055
3.0	2960	V6	1989	1996	Non-Turbo From 2/1/89	06045
3.0	2960	V6	1990	1990	Twin Turbo	06046
3.0	2960	V6	1991	1991	Twin Turbo	06046
3.0	2960	V6	1992	1992	Twin Turbo	06046
3.0	2960	V6	1993	1994	Twin Turbo	06046
3.0	2960	V6	1995	1996	Twin Turbo	06046
310						
1.5	1488	L4	1981	1981	From 8/81	06021
1.5	1488	L4	1982	1982	—	06021
350Z						
3.5	3498	V6	2003	2006	Sold As Kit Only	NSK1000
3.5	3498	V6	2003	2006	Sold As Kit Only, Solid FW Conversion for OEM Dual Mass FW, Economy version	NSK1000FW
3.5	3498	V6	2007	2009	Dual Mass Flywheel Conversion, Will only work with EXEDY cover and disc, VQ35HR, Sold as Kit Only, Includes Solid Flywheel, Includes CSC Hydraulic Slave	NSK1024FW
3.5	3498	V6	2007	2009	Direct OE Replacement to work with factory DMF	NSK1037
370Z						
3.7	3696	V6	2009	2018	Dual Mass Flywheel Conversion, Will only work with EXEDY cover and disc, VQ35HR, Sold as Kit Only, Includes Solid Flywheel, Includes CSC Hydraulic Slave	NSK1024FW
3.7	3498	V6	2009	2018	Direct OE Replacement to work with factory DMF	NSK1037
411						
1.6	1595	L4	1967	1967	—	06022
510						
1.6	1595	L4	1968	1969	To 2/69	06020
1.6	1595	L4	1969	1973	From 3/69	06020
2.0	1952	L4	1978	1981	—	06008
610						
1.8	1770	L4	1973	1973	—	06020
2.0	1952	L4	1974	1975	To 10/75	06008
2.0	1952	L4	1975	1976	From 11/75	06008

2

EXEDY OEM	Disc (mm)	Disc (in)	Spline Dia	Splines	Master Cylinder	Slave Cylinder	Clutch Cable	Clutch Fork	New Flywheel
—	184	7-1/4	13/16	18	MC153	SC558	—	—	—
—	184	7-1/4	13/16	18	MC153	SC558	—	—	—
—	184	7-1/4	13/16	18	MC153	SC558	—	—	—
Y	225	8-7/8	1	24	MC153	SC560	—	—	—
Y	225	8-7/8	1	24	MC153	SC563	—	—	—
—	225	8-7/8	1	24	MC169	SC571	—	—	—
—	225	8-7/8	1	24	MC169	SC559	—	—	—
—	225	8-7/8	1	24	MC169	SC563	—	—	—
—	225	8-7/8	1	24	MC169	SC559	—	—	—
Y	225	8-7/8	1	24	MC169	SC559	—	—	—
Y	225	8-7/8	1	24	MC166	SC559	—	—	—
—	240	9-1/2	1	24	MC169	SC559	—	—	—
—	240	9-1/2	1	24	MC166	SC559	—	—	—
Y	225	8-7/8	1	24	MC153	SC563	—	—	—
—	240	9-1/2	1	24	MC153	SC563	—	—	—
—	240	9-1/2	1	24	MC168	SC563	—	—	—
Y	240	9-1/2	1	24	MC168	SC572	—	CF114	—
—	240	9-1/2	1	24	MC168	SC572	—	—	—
—	250	9-7/8	1	24	MC168	SC572	—	CF114	—
—	240	9-1/2	1	24	—	SC572	—	—	—
—	250	9-7/8	1	24	MC507	SC572	—	—	—
—	250	9-7/8	1	24	—	SC572	—	—	—
—	250	9-7/8	1	24	MC506	SC572	—	—	—
—	250	9-7/8	1	24	—	SC572	—	—	—
—	250	9-7/8	1	24	MC506	SC572	—	—	—
Y	184	7-1/4	13/16	18	MC153	—	—	—	—
Y	184	7-1/4	13/16	18	—	—	—	—	—
Y	250	9-7/8	1	24	—	—	—	—	—
Y	250	9-7/8	1	24	—	—	—	—	—
—	250	9-7/8	1	24	—	BRG0163	—	—	—
—	250	9-7/8	1	24	—	BRG0163	—	—	—
—	250	9-7/8	1	24	—	BRG0163	—	—	—
—	250	9-7/8	1	24	—	BRG0163	—	—	—
—	200	7-7/8	1	24	—	—	—	—	—
—	200	7-7/8	1	24	MC161	SC569	—	—	—
—	200	7-7/8	1	24	MC165	SC569	—	—	—
Y	200	7-7/8	1	24	MC151	SC560	—	—	—
—	200	7-7/8	1	24	MC165	SC563	—	—	—
Y	200	7-7/8	1	24	MC165	SC559	—	—	—
Y	200	7-7/8	1	24	MC166	SC559	—	—	—

2

Liter	CC/IN	Cyl	Years		Application Information	Kit
			To	From		
NISSAN continued						
710						
1.8	1770	L4	1974	1974	—	06008
2.0	1952	L4	1975	1977	—	06008
810						
2.4	2393	L6	1977	1980	—	06034
2.4	2393	L6	1981	1981	—	06034
2.8	2793	L6	1981	1981	Diesel	06034
ALTIMA						
2.4	2389	L4	1993	1997	—	KNS04
2.4	2389	L4	1998	2001	—	KNS06
2.5	2500	L4	2002	2006	—	NSK1003
2.5	2500	L4	2007	2012	Sold as Kit Only, Includes CSC Hydraulic Slave Cylinder	NSK1008
3.5	3498	V6	2002	2003	Sold As Kit Only	NSK1002
3.5	3498	V6	2004	2006	Sold As Kit Only	NSK1002
B210						
1.4	1393	L4	1975	1975	4 Spd,7-1/8"	06018
1.4	1393	L4	1975	1978	4 Spd,7-1/4"	06001
1.4	1393	L4	1976	1976	4 Spd,7-1/8"	06018
1.4	1393	L4	1977	1978	4 Spd,7-1/8"	06018
MAXIMA						
2.4	2393	L6	1982	1984	—	06034
3.0	2960	V6	1985	1988	—	06044
3.0	2960	V6	1989	1993	—	06044
3.0	2960	V6	1994	1994	To 1/94	06044
3.0	2960	V6	1994	1994	From 2/94	06044
3.0	2988	V6	1995	1999	To 3/99	06044
3.0	2988	V6	1999	2001	From 4/99	06044
3.5	3498	V6	2002	2003	Sold As Kit Only	NSK1002
3.5	3498	V6	2004	2006	Sold As Kit Only	NSK1002
MICRA (CANADA)						
1.2	1229	L4	1984	1991	—	06041
NX						
1.6	1597	L4	1991	1993	—	06040
2.0	1998	L4	1991	1993	—	KNS02
PULSAR						
1.5	1488	L4	1983	1984	Turbo	06007
1.6	1597	L4	1983	1986	SOHC	06021
1.6	1597	L4	1987	1987	DOHC	06049
1.6	1597	L4	1987	1990	SOHC	06040
1.8	1809	L4	1988	1989	DOHC	06050
SENTRA						
1.5	1488	L4	1982	1983	—	06021
1.6	1597	L4	1983	1985	—	06021
1.6	1597	L4	1986	1987	—	06040
1.6	1597	L4	1988	1988	To 7/88	06040
1.6	1597	L4	1989	1990	—	06040
1.6	1597	L4	1990	1990	4 WD Canada	06007
1.6	1597	L4	1991	1991	—	06040
1.6	1597	L4	1991	1991	Canada	06040
1.6	1597	L4	1992	1993	Canada	06040
1.6	1597	L4	1992	1994	—	06040
1.6	1597	L4	1995	1999	—	KNS05
1.7	1688	L4	1983	1986	Diesel	06021
1.7	1688	L4	1987	1987	Diesel Canada	06048
1.8	1809	L4	2000	2000	—	KNS02
1.8	1809	L4	2001	2006	—	KNS02

EXEDY OEM	Disc (mm)	Disc (in)	Spline Dia	Splines	Master Cylinder	Slave Cylinder	Clutch Cable	Clutch Fork	New Flywheel
Y	200	7-7/8	1	24	MC165	SC563	—	—	—
Y	200	7-7/8	1	24	MC151	SC563	—	—	—
—	225	8-7/8	1	24	MC151	SC563	—	—	—
—	225	8-7/8	1	24	MC153	SC563	—	—	—
—	225	8-7/8	1	24	MC153	SC563	—	—	—
Y	225	8-7/8	1	24	MC500	SC565	—	—	—
Y	225	8-7/8	1	24	MC549	SC565	—	—	—
—	240	9-1/2	1	24	MC541	SC864	—	—	—
Y	240	9-1/2	15/16	21	—	BRG0166	—	—	—
—	240	9-1/2	1	24	MC541	SC864	—	—	—
—	240	9-1/2	1	24	MC541	SC865	—	—	—
—	180	7-1/8	1	24	MC165	SC558	—	—	—
—	184	7-1/4	13/16	18	MC467	SC558	—	—	—
—	180	7-1/8	1	24	MC467	SC558	—	—	—
—	180	7-1/8	1	24	MC152	SC560	—	—	—
—	225	8-7/8	1	24	—	SC563	—	—	—
—	240	9-1/2	1	24	MC153	SC562	—	—	—
—	240	9-1/2	1	24	MC168	SC565	—	—	—
—	240	9-1/2	1	24	MC153	SC565	—	—	—
—	240	9-1/2	1	24	MC547	SC851	—	—	—
—	240	9-1/2	1	24	MC160	SC565	—	—	—
—	240	9-1/2	1	24	MC162	SC565	—	—	—
—	240	9-1/2	1	24	MC545	SC864	—	—	—
—	240	9-1/2	1	24	MC541	SC864	—	—	—
—	160	6-5/16	11/16	16	—	—	CC806	—	—
Y	190	7-1/2	13/16	18	—	—	—	—	NSF501
Y	215	8-1/2	13/16	18	—	—	—	—	—
Y	200	7-7/8	13/16	18	—	—	CC800	—	—
Y	184	7-1/4	13/16	18	—	—	CC800	—	—
—	200	7-7/8	13/16	18	—	—	CC807	—	—
Y	190	7-1/2	13/16	18	—	—	CC806	—	NSF501
—	215	8-7/16	1	24	—	SC655	CC806	—	—
Y	184	7-1/4	13/16	18	—	—	—	—	—
Y	184	7-1/4	13/16	18	—	—	—	—	—
Y	190	7-1/2	13/16	18	—	—	CC807	—	NSF501
Y	190	7-1/2	13/16	18	—	—	CC807	—	NSF501
Y	190	7-1/2	13/16	18	—	—	—	—	NSF501
Y	200	7-7/8	13/16	18	—	—	—	—	—
Y	190	7-1/2	13/16	18	—	—	CC810	—	—
Y	190	7-1/2	13/16	18	—	—	CC810	—	NSF501
Y	190	7-1/2	13/16	18	—	—	—	—	NSF501
Y	190	7-1/2	13/16	18	—	—	—	—	NSF501
Y	190	7-1/2	13/16	18	—	—	—	—	NSF501
Y	184	7-1/4	13/16	18	—	—	—	—	NSF501
—	190	7-1/2	13/16	18	—	—	—	—	—
Y	215	8-1/2	13/16	18	—	—	—	—	—
Y	215	8-1/2	13/16	18	MC542	SC760	—	—	—

2

Liter	CC/IN	Cyl	Years		Application Information	Kit
			To	From		
NISSAN continued						
<i>SENTRA continued</i>						
2.0	1998	L4	1991	2000	—	KNS02
2.0	1998	L4	2001	2001	—	KNS02
2.0	1997	L4	2007	2011	Sold as Kit Only, Includes CSC Hydraulic Slave Cylinder	NSK1009
2.5	2500	L4	2002	2006	—	NSK1003
2.5	2500	L4	2007	2012	SE-R Spec-V, Sold as Kit Only, Includes CSC Hydraulic Slave Cylinder	NSK1008
STANZA						
2.0	1974	L4	1982	1985	—	06007
2.0	1974	L4	1986	1986	—	06043
2.0	1974	L4	1987	1987	From 9/87	06043
2.0	1974	L4	1987	1987	To 8/87	06043
2.0	1974	L4	1988	1988	—	06043
2.4	2389	L4	1990	1992	—	06053
VERSA						
1.8	1798	L4	2007	2011	Sold as Kit Only, Includes CSC Hydraulic Slave Cylinder	NSK1009
1.8	1798	L4	2007	2012	Sold as kit only, Solid Flywheel Conversion, Includes Solid flywheel, Includes CSC Hydraulic Slave Cylinder	NSK1026FW
NISSAN LIGHT TRUCK, SUV & VAN						
520 PICKUP						
1.3	1299	L4	1965	1968	—	06019
521 PICKUP						
1.3	1299	L4	1969	1969	—	06019
1.6	1595	L4	1970	1971	—	06022
1.6	1595	L4	1972	1972	—	06022
620 PICKUP						
1.6	1595	L4	1972	1973	—	06022
1.8	1770	L4	1974	1974	—	06033
2.0	1952	L4	1975	1976	2 WD To 2/76	06004
2.0	1952	L4	1976	1979	2 WD From 3/76	06004
720 PICKUP						
2.0	1952	L4	1980	1980	2 WD	06004
2.0	1952	L4	1980	1980	4 WD	06004
2.0	1952	L4	1983	1985	2 WD To 10/85	06006
2.0	1952	L4	1985	1985	2 WD From 11/85	06006
2.0	1952	L4	1985	1985	4 WD To 10/85	06006
2.0	1952	L4	1985	1985	4 WD From 11/85	06006
2.2	2187	L4	1981	1982	4 WD	06004
2.2	2164	L4	1981	1983	Diesel 2 WD	06004
2.2	2164	L4	1981	1983	Diesel 4 WD	06004
2.2	2187	L4	1981	1983	2 WD/4 WD	06004
2.4	2389	L4	1983	1985	2 WD	06006
2.4	2389	L4	1983	1985	4 WD	06006
2.4	2389	L4	1986	1986	2 WD	06006
2.4	2389	L4	1986	1986	4 WD	06006
2.5	2488	L4	1983	1985	Diesel	06034
2.5	2488	L4	1986	1986	Diesel	06034
AXXESS						
2.4	2389	L4	1990	1991	2 WD	06053
2.4	2389	L4	1991	1991	4 WD	06051
CUBE						
1.8	1798	L4	2009	2011	Sold as Kit Only, Includes CSC Hydraulic Slave Cylinder	NSK1009
D21 PICKUP						
2.4	2389	L4	1986	1988	—	06006
2.4	2389	L4	1989	1992	—	06006
2.4	2389	L4	1993	1993	—	KNS03
3.0	2960	V6	1986	1988	—	06042
3.0	2960	V6	1989	1993	—	06042

EXEDY OEM	Disc (mm)	Disc (in)	Spline Dia	Splines	Master Cylinder	Slave Cylinder	Clutch Cable	Clutch Fork	New Flywheel
Y	215	8-1/2	13/16	18	—	—	—	—	—
Y	215	8-1/2	13/16	18	MC542	SC760	—	—	NSF504
—	225	8-7/8	15/16	21	—	BRG0166	—	—	NSF504
—	240	9-1/2	1	24	MC542	SC864	—	—	—
Y	240	9-1/2	15/16	21	—	BRG0166	—	—	—
Y	200	7-7/8	13/16	18	—	—	—	—	—
Y	225	8-7/8	1	24	MC153	SC564	—	—	—
Y	225	8-7/8	1	24	MC153	SC565	—	—	—
Y	225	8-7/8	1	24	MC153	SC564	—	—	—
Y	225	8-7/8	1	24	MC153	SC565	—	—	—
Y	225	8-7/8	1	24	MC153	SC565	—	—	—
—	225	8-7/8	15/16	21	—	BRG0166	—	—	—
—	225	8-7/8	15/16	21	—	BRG0166	—	—	FWNS01
—	200	7-7/8	1	24	—	—	—	—	—
—	200	7-7/8	1	24	MC501	—	—	—	—
—	200	7-7/8	1	24	MC501	—	—	—	—
—	200	7-7/8	1	24	MC151	SC574	—	—	—
—	200	7-7/8	1	24	MC165	SC574	—	—	—
—	225	8-7/8	1	24	MC165	SC574	—	—	—
Y	225	8-7/8	1	24	MC151	SC574	—	CF114	—
Y	225	8-7/8	1	24	MC152	SC574	—	CF114	—
Y	225	8-7/8	1	24	MC153	SC574	—	CF114	—
Y	225	8-7/8	1	24	MC153	SC883	—	CF114	—
Y	240	9-1/2	1	24	MC153	SC574	—	CF114	FWNS28
Y	240	9-1/2	1	24	MC157	SC577	—	CF114	FWNS28
Y	240	9-1/2	1	24	MC153	SC575	—	CF114	FWNS28
Y	240	9-1/2	1	24	MC157	SC576	—	CF114	FWNS28
Y	225	8-7/8	1	24	MC153	SC575	—	CF114	—
Y	225	8-7/8	1	24	MC153	SC574	—	CF114	—
Y	225	8-7/8	1	24	MC153	SC883	—	CF114	—
Y	225	8-7/8	1	24	MC153	SC574	—	CF114	—
Y	240	9-1/2	1	24	MC153	SC574	—	CF114	FWNS28
Y	240	9-1/2	1	24	MC153	SC575	—	CF114	FWNS28
Y	240	9-1/2	1	24	—	SC574	—	CF114	FWNS28
Y	240	9-1/2	1	24	—	SC575	—	CF114	FWNS28
—	225	8-7/8	1	24	—	SC883	—	—	—
—	225	8-7/8	1	24	MC157	SC883	—	—	—
Y	225	8-7/8	1	24	MC158	SC565	—	—	—
Y	240	9-1/2	1	24	MC158	SC565	—	—	—
—	225	8-7/8	15/16	21	—	—	—	—	—
Y	240	9-1/2	1	24	MC157	SC882	—	CF114	FWNS28
Y	240	9-1/2	1	24	MC157	SC882	—	—	FWNS28
Y	240	9-1/2	1	24	MC157	SC882	—	—	—
Y	250	9-7/8	1	24	MC157	SC576	—	CF114	FWNS27
Y	250	9-7/8	1	24	MC157	SC576	—	—	FWNS27

2

Liter	CC/IN	Cyl	Years		Application Information	Kit
			To	From		
NISSAN LIGHT TRUCK, SUV & VAN continued						
FRONTIER						
2.4	2389	L4	1998	1999	—	06059
2.4	2389	L4	2000	2004	—	NSK1004
2.5	2500	L4	2005	2016	Sold as kit only, Fits Dual Mass FW	NSK1005
3.3	3275	V6	2000	2004	—	KNS10
3.3	3275	V6	2001	2004	Supercharged	NSK1007
4.0	3954	V6	2005	2014	Sold as kit only	NSK1006
JUKE						
1.6	1618	L4	2011	2016	Sold as kit only, Solid Flywheel Conversion, Includes Solid flywheel, Includes CSC Hydraulic Slave Cylinder (Excludes NISMO RS model)	NSK1026FW
PATHFINDER						
2.4	2389	L4	1987	1988	—	06006
3.0	2960	V6	1987	1989	—	06042
3.0	2960	V6	1990	1995	—	06042
3.3	3275	V6	1996	1996	—	KNS12
3.3	3275	V6	1997	1999	—	06058
3.3	3275	V6	2000	2000	—	KNS10
3.5	3498	V6	2001	2002	—	KNS07
PICKUP						
2.4	2389	L4	1994	1995	—	KNS03
2.4	2389	L4	1996	1996	2 WD, From 2/1/96	06059
2.4	2389	L4	1996	1996	4 WD, From 2/1/96	06059
2.4	2389	L4	1996	1996	RWD	06059
2.4	2389	L4	1996	1996	To 1/31/96	KNS03
2.4	2389	L4	1997	1997	2 WD	06059
2.4	2389	L4	1997	1997	4 WD	06059
3.0	2960	V6	1994	1996	—	06042
VAN						
2.4	2389	L4	1987	1988	—	06034
XTERRA						
2.4	2389	L4	2000	2000	—	06059
3.3	3275	V6	2000	2004	—	KNS10
3.3	3275	V6	2002	2003	Supercharged	NSK1007
4.0	3954	V6	2005	2015	Sold as kit only	NSK1006
OLDSMOBILE (Performance Applications Available)						
ACHIEVA						
2.3	140	L4	1992	1992	Quad 4, 8th Digit of VIN is A with CSC	04088
2.3	140	L4	1992	1992	Quad 4, 8th Digit of VIN is A with External CSC Slave	04088
2.3	140	L4	1992	1994	SOHC, 8th Digit of VIN is 3	04135
2.3	140	L4	1993	1994	Quad 4, 8th Digit of VIN is A, Includes Slave Cylinder	04136
2.3	140	L4	1995	1995	Includes Slave Cylinder	04162
2.4	146	L4	1996	1997	Includes Slave Cylinder	04162
ALERO						
2.2	134	L4	2002	2004	DOHC, Includes Slave Cylinder, Sold As Kit Only	GMK1000
2.4	146	L4	2000	2001	Includes Slave Cylinder, Sold As Kit Only	KGM04
CALAIS (FWD)						
2.5	153	L4	1986	1986	—	04005
2.5	153	L4	1987	1987	—	04005
CUTLASS CIERA (FWD)						
2.5	153	L4	1984	1984	—	04077
CUTLASS, DELMONT 88, DELTA 88, DYNAMIC, F85, JET STAR 88, OMEGA, STARFIRE, VISTA CRUISER						
2.5	153	L4	1980	1984	14 Spline Disc	04077
2.8	171	V6	1980	1984	—	04077
2.8	171	V6	1988	1988	—	04088
2.8	171	V6	1989	1989	Quad 4	04088
3.1	189	V6	1989	1990	—	04116

EXEDY OEM	Disc (mm)	Disc (in)	Spline Dia	Splines	Master Cylinder	Slave Cylinder	Clutch Cable	Clutch Fork	New Flywheel
Y	240	9-1/2	1	24	MC550	SC572	—	—	—
—	240	9-1/2	1	24	MC552	SC572	—	—	—
Y	240	9 1/2	1	24	MC571	SC902	—	—	—
Y	250	9-7/8	1	24	MC552	SC572	—	—	NSF502/NSF510
Y	250	9-7/8	1	24	MC552	SC572	—	—	—
Y	260	10 1/4	1	24	MC571	SC903	—	—	—
—	225	8-7/8	15/16	21	—	BRG0166	—	—	FWNS01
Y	240	9-1/2	1	24	MC157	SC884	—	—	FWNS28
Y	250	9-7/8	1	24	MC157	SC576	—	—	FWNS27
Y	250	9-7/8	1	24	MC157	SC576	—	—	—
Y	250	9-7/8	1	24	MC162	SC572	—	CF114	NSF502/NSF510
Y	250	9-7/8	1	24	MC162	SC572	—	—	NSF502/NSF510
Y	250	9-7/8	1	24	MC162	SC572	—	—	NSF502/NSF510
—	250	9-7/8	1	24	MC551	SC872	—	—	—
Y	240	9-1/2	1	24	MC157	SC577	—	—	—
Y	240	9-1/2	1	24	MC161	SC577	—	—	—
Y	240	9-1/2	1	24	MC161	SC576	—	—	—
Y	240	9-1/2	1	24	MC161	SC576	—	—	—
Y	240	9-1/2	1	24	MC157	SC884	—	—	—
Y	240	9-1/2	1	24	MC161	SC577	—	—	—
Y	240	9-1/2	1	24	MC161	SC576	—	—	—
Y	250	9-7/8	1	24	MC157	SC884	—	—	—
—	225	8-7/8	1	24	MC156	SC563	—	—	—
Y	240	9-1/2	1	24	MC548	SC572	—	—	—
Y	250	9-7/8	1	24	MC548	SC572	—	—	NSF502/NSF510
Y	250	9-7/8	1	24	MC548	SC572	—	—	—
Y	260	10 1/4	1	24	MC571	SC903	—	—	—
Y	225	8-7/8	15/16	14	MC330	SC715	—	—	—
Y	225	8-7/8	15/16	14	MC330	SC715	—	—	—
Y	225	8-7/8	15/16	14	MC325	SC715	—	—	—
Y	225	8-7/8	15/16	14	MC330	SC715	—	—	—
Y	225	8-7/8	15/16	14	MC330	SC715	—	—	—
Y	225	8-7/8	15/16	14	MC330	—	—	—	—
Y	225	8-7/8	1	14	—	—	—	—	—
Y	225	8-7/8	1	14	—	—	—	—	—
Y	215	8-1/2	1	14	MC326	SC723	—	—	—
Y	215	8-1/2	1	14	MC317	SC723	—	—	—
—	225	8-7/8	15/16	14	—	—	—	—	—
—	225	8-7/8	15/16	14	—	—	—	—	—
—	225	8-7/8	15/16	14	—	—	—	—	FWGM111
Y	225	8-7/8	15/16	14	MC322	SC715	—	—	FWGM111
Y	225	8-7/8	15/16	14	MC322	SC715	—	—	—
—	225	8-7/8	15/16	14	—	SC715	—	—	—

2

Liter	CC/IN	Cyl	Years		Application Information	Kit
			To	From		

OLDSMOBILE (Performance Applications Available) continued

CUTLASS, DELMONT 88, DELTA 88, DYNAMIC, F85, JET STAR 88, OMEGA, STARFIRE, VISTA CRUISER continued

3.8	232	V6	1979	1981	—	04021
5.0	305	V8	1979	1979	—	04021
5.4	330	V8	1965	1967	11" Disc	04049
5.7	348	V8	1969	1970	W-31	04021
5.7	348	V8	1971	1973	3 Spd, 4 BBL	04021
5.7	348	V8	1971	1973	4 Spd, 4 BBL with 10-3/8" Disc	04019
5.7	348	V8	1971	1973	4 Spd, 4 BBL with 11" Disc	04020
6.6	403	V8	1966	1969	—	04049
7.0	427	V8	1965	1965	—	04021
7.0	427	V8	1965	1967	—	04049
7.5	458	V8	1968	1973	3 Spd	04049
7.5	458	V8	1971	1973	4 Spd	04020

FIRENZA

1.8	110	L4	1983	1986	—	04046
2.0	122	L4	1985	1985	5 Spd	04005
2.0	122	L4	1985	1986	4 Spd	04077
2.0	122	L4	1986	1986	OHV, 5 Spd	04005
2.0	122	L4	1987	1987	4 Spd	04077
2.0	122	L4	1988	1988	OHC,TBI,OHV	04046
2.8	171	V6	1985	1986	—	04077
2.8	171	V6	1987	1987	—	04088

2 PEUGEOT

505

2.0	1971	L4	1983	1987	Sold As Kit Only	KPT03
-----	------	----	------	------	------------------	-------

PLYMOUTH (Performance Applications Available)

ARROW

1.6	98	L4	1976	1980	—	05020
2.0	122	L4	1976	1977	—	05012
2.6	159	L4	1979	1979	GT	05041
2.6	159	L4	1979	1980	—	05052

BARRACUDA, BELVEDERE, DUSTER, FURY, GRAND FURY, GTX, PLAZA, ROADRUNNER, SATELLITE, SAVOY, SCAMP, VALIANT, VOLARE

4.5	275	V8	1956	1956	10-3/8" Disc	05029
4.5	275	V8	1956	1957	10-3/8" Disc	05029
4.5	275	V8	1964	1969	10-3/8" Disc	05029
5.2	317	V8	1957	1958	10-3/8" Disc	05029
5.2	317	V8	1958	1978	10-3/8" Disc	05029
5.6	342	V8	1968	1973	10-3/8" Disc	05029
5.9	360	V8	1959	1979	10-3/8" Disc	05029
6.3	384	V8	1960	1971	10-3/8" Disc	05029
6.3	384	V8	1968	1969	10-3/8" Disc	05029
7.0	427	V8	1963	1971	10-3/8" Disc	05029

BREEZE

2.0	122	L4	1996	2000	Modular Clutch Includes Flywheel	05085
2.4	146	L4	1998	2000	Modular Clutch Includes Flywheel	05085

CHAMP

1.4	85	L4	1979	1982	2 Door Hatchback	05022
1.4	85	L4	1979	1982	Dual Range 4 Spd	05023
1.6	98	L4	1979	1982	2 Door Hatchback	05023

EXEDY OEM	Disc (mm)	Disc (in)	Spline Dia	Splines	Master Cylinder	Slave Cylinder	Clutch Cable	Clutch Fork	New Flywheel
—	265	10-1/2	1-1/8	10	—	—	—	—	—
—	265	10-1/2	1-1/8	10	—	—	—	—	FWGM101
—	280	11	1-1/8	10	—	—	—	—	—
—	265	10-1/2	1-1/8	10	—	—	—	—	FWGM101
—	265	10-1/2	1-1/8	10	—	—	—	—	FWGM101
—	263	10-3/8	1-1/8	26	—	—	—	—	FWGM101
—	280	11	1-1/8	26	—	—	—	—	—
—	280	11	1-1/8	10	—	—	—	—	—
—	265	10-1/2	1-1/8	10	—	—	—	—	—
—	280	11	1-1/8	10	—	—	—	—	—
—	280	11	1-1/8	10	—	—	—	—	—
—	280	11	1-1/8	26	—	—	—	—	—
—	215	8-1/2	1	14	MC318	SC714	—	—	—
Y	215	8-1/2	1	14	MC316	SC714	—	—	—
—	225	8-7/8	15/16	14	MC318	SC714	—	—	—
Y	215	8-1/2	1	14	MC316	SC714	—	—	—
—	225	8-7/8	15/16	14	—	SC714	—	—	—
—	215	8-1/2	1	14	MC316	SC714	—	—	—
—	225	8-7/8	15/16	14	MC318	SC714	—	—	FWGM111
Y	225	8-7/8	15/16	14	MC316	SC714	—	—	FWGM111
—	215	8-7/16	1-1/8	10	—	—	—	—	—
—	200	7-7/8	7/8	20	—	—	—	—	—
—	215	8-7/16	7/8	20	—	—	—	—	—
Y	225	8-7/8	1-1/32	23	—	—	—	—	—
Y	225	8-7/8	1-1/32	23	—	—	—	—	—
—	263	10-3/8	1	23	—	—	—	—	—
—	263	10-3/8	1	23	—	—	—	—	—
—	263	10-3/8	1	23	—	—	—	—	—
—	263	10-3/8	1	23	—	—	—	—	—
—	263	10-3/8	1	23	—	—	—	—	—
—	263	10-3/8	1	23	—	—	—	—	—
—	263	10-3/8	1	23	—	—	—	—	—
—	263	10-3/8	1	23	—	—	—	—	FWCHR106
—	263	10-3/8	1	23	—	—	—	—	—
—	230	9-1/16	15/16	17	—	—	—	—	—
—	230	9-1/16	15/16	17	—	—	—	—	—
Y	200	7-7/8	7/8	20	—	—	—	—	—
Y	184	7-1/4	7/8	20	—	—	—	—	—
Y	184	7-1/4	7/8	20	—	—	—	—	—

Liter	CC/IN	Cyl	Years		Application Information	Kit
			To	From		
PLYMOUTH (Performance Applications Available) continued						
<i>COLT</i>						
1.4	85	L4	1979	1982	4 Spd Luk	05026
1.4	85	L4	1979	1984	Dual Range 4 Spd Luk	05023
1.4	85	L4	1983	1984	7-7/8" Disc 4 Spd	05026
1.5	92	L4	1985	1986	4 Spd,7-7/8"	05026
1.5	92	L4	1985	1986	5 Speed ,7-1/4"	05023
1.5	92	L4	1985	1988	4 Spd	05026
1.5	92	L4	1985	1988	5 Spd	05023
1.5	92	L4	1989	1994	—	05026
1.6	98	L4	1976	1978	—	05020
1.6	98	L4	1979	1981	Wagon	05020
1.6	98	L4	1979	1982	Sedan	05023
1.6	98	L4	1983	1983	Hatchback	05023
1.6	98	L4	1984	1984	Dual Range 4 Spd	05022
1.6	98	L4	1984	1984	Turbo, Dual Range 4 Spd	05022
1.6	98	L4	1985	1988	Turbo 3 Speed and 5 Speed	05026
1.6	98	L4	1989	1990	5 Spd	05051
1.6	98	L4	1989	1990	Turbo, 5 Spd	05051
1.8	110	L4	1989	1990	5 Spd	05051
1.8	110	L4	1992	1992	2 WD with 8-3/8" Disc	05051
1.8	110	L4	1992	1992	FWD 8-1/2" Disc	05021
1.8	110	L4	1992	1994	—	05051
1.8	110	L4	1992	1994	2 WD	05051
1.8	110	L4	1992	1994	4 WD	05021
2.0	122	L4	1976	1978	—	05021
2.0	122	L4	1984	1984	8-1/2" Disc FWD	05021
2.0	122	L4	1984	1985	2 WD with 7-7/8" Disc	05026
2.0	122	L4	1985	1989	4 WD	05021
2.0	122	L4	1986	1986	3 Speed and 5 Speed	05026
2.0	122	L4	1986	1986	5 Speed	05023
2.0	122	L4	1986	1987	2 WD with 7-7/8" Disc	05026
2.0	122	L4	1987	1987	2 WD with 8-3/8" Disc	05051
2.0	122	L4	1988	1989	2 WD	05051
2.0	122	L4	1990	1990	2 WD 8-1/4" Disc	05051
2.0	122	L4	1990	1990	FWD 8-1/2" Disc	05021
2.0	122	L4	1991	1991	2 WD	05051
2.0	122	L4	1991	1991	4 WD	05021
2.4	146	L4	1992	1992	Sold As Kit Only	05048
2.4	146	L4	1993	1994	Sold As Kit Only	05048
2.6	159	L4	1978	1980	—	05041
<i>CONQUEST</i>						
2.6	159	L4	1984	1984	Non Intercooled Turbo	05025
2.6	159	L4	1984	1986	Non-intercooled, Turbo	05025
2.6	159	L4	1985	1986	Turbo,Intercooled	05046
2.6	159	L4	1987	1987	—	05046
2.6	159	L4	1988	1989	Intercooled Turbo	05049
<i>HORIZON, SCAMP, TURISMO</i>						
2.2	134	L4	1981	1989	Sold As Kit Only	05028A
2.2	134	L4	1990	1990	—	05061
<i>LASER</i>						
1.8	110	L4	1990	1991	—	05022
1.8	110	L4	1992	1994	—	05022
2.0	122	L4	1990	1991	Non-Turbo with Speed Control	05051
2.0	122	L4	1990	1991	Non-Turbo without Speed Control	05051
2.0	122	L4	1990	1991	Turbo, 2 WD with Speed Control, Sold As Kit Only	05048
2.0	122	L4	1990	1991	Turbo, 4 WD with Speed Control, Sold as Kit Only	05048

2

EXEDY OEM	Disc (mm)	Disc (in)	Spline Dia	Splines	Master Cylinder	Slave Cylinder	Clutch Cable	Clutch Fork	New Flywheel
Y	200	7-7/8	7/8	20	—	—	—	—	—
Y	184	7-1/4	7/8	20	—	—	—	—	—
Y	200	7-7/8	7/8	20	—	—	—	—	—
Y	200	7-7/8	7/8	20	—	—	—	—	—
Y	184	7-1/4	7/8	20	MC194	SC580	—	—	—
Y	200	7-7/8	7/8	20	—	—	—	—	—
Y	184	7-1/4	7/8	20	MC194	SC580	—	—	—
Y	200	7-7/8	7/8	20	MC178	SC580	—	—	—
—	200	7-7/8	7/8	20	—	—	—	—	—
—	200	7-7/8	7/8	20	—	—	—	—	—
Y	184	7-1/4	7/8	20	—	—	—	—	—
Y	184	7-1/4	7/8	20	—	—	—	—	—
Y	200	7-7/8	7/8	20	MC203	SC580	—	—	—
Y	200	7-7/8	7/8	20	MC203	SC580	—	—	—
Y	200	7-7/8	7/8	20	—	—	—	—	—
Y	215	8-1/2	7/8	20	MC178	SC581	—	—	—
Y	215	8-1/2	7/8	20	MC178	SC581	—	—	—
Y	215	8-1/2	7/8	20	MC178	SC589	—	—	—
Y	215	8-1/2	7/8	20	MC175	SC589	—	—	—
—	215	8-1/2	7/8	20	MC175	SC589	—	—	—
Y	215	8-1/2	7/8	20	—	—	—	—	—
Y	215	8-1/2	7/8	20	—	SC589	—	—	—
—	215	8-1/2	7/8	20	—	SC589	—	—	—
—	215	8-1/2	7/8	20	—	—	—	—	—
—	215	8-1/2	7/8	20	—	—	—	—	—
Y	200	7-7/8	7/8	20	—	—	—	—	—
—	215	8-1/2	7/8	20	MC175	SC583	—	—	—
Y	200	7-7/8	7/8	20	—	—	—	—	—
Y	184	7-1/4	7/8	20	MC194	SC580	—	—	—
Y	200	7-7/8	7/8	20	MC175	SC581	—	—	—
Y	215	8-1/2	7/8	20	MC175	—	—	—	—
Y	215	8-1/2	7/8	20	MC175	—	—	—	—
Y	215	8-1/2	7/8	20	MC175	—	—	—	—
—	215	8-1/2	7/8	20	MC175	SC583	—	—	—
Y	215	8-1/2	7/8	20	MC175	—	—	—	—
—	215	8-1/2	7/8	20	MC175	SC583	—	—	—
Y	225	8-7/8	7/8	20	—	SC584	—	—	—
Y	225	8-7/8	7/8	20	—	SC589	—	—	—
Y	225	8-7/8	1-1/32	23	—	—	—	—	—
Y	225	8-7/8	1-1/32	23	MC175	SC579	—	—	—
Y	225	8-7/8	1-1/32	23	MC175	SC821	—	—	—
Y	225	8-7/8	1-1/32	23	MC175	SC579	—	—	—
Y	225	8-7/8	1-1/32	23	MC175	SC579	—	—	—
Y	240	9-1/2	1-1/16	23	MC175	SC679	—	—	—
—	215	8-7/16	13/16	18	—	—	—	—	—
—	215	8-7/16	13/16	18	—	—	—	—	—
Y	200	7-7/8	7/8	20	MC179	SC581	—	—	—
Y	200	7-7/8	7/8	20	MC180	SC581	—	—	—
Y	215	8-1/2	7/8	20	MC180	SC581	—	—	—
Y	215	8-1/2	7/8	20	MC179	SC581	—	—	—
Y	225	8-7/8	7/8	20	MC180	SC586	—	—	—
Y	225	8-7/8	7/8	20	MC180	SC587	—	—	—

Liter	CC/IN	Cyl	Years		Application Information	Kit
			To	From		

PLYMOUTH (Performance Applications Available) continued

LASER continued

2.0	122	L4	1990	1991	Turbo, 4 WD without Speed Control, Sold as Kit Only	05048
2.0	122	L4	1990	1992	Turbo, 2 WD without Speed Control, Sold As Kit Only	05048
2.0	122	L4	1992	1992	2 WD with Speed Control, Sold As Kit Only	05048
2.0	122	L4	1992	1992	4 WD with Speed Control, Sold As Kit Only	05048
2.0	122	L4	1992	1992	4 WD without Speed Control, Sold As Kit Only	05048
2.0	122	L4	1992	1994	Non-Turbo	05051
2.0	122	L4	1993	1994	Turbo, 2 WD, Sold As Kit Only	05048
2.0	122	L4	1993	1994	Turbo, 4 WD, Sold As Kit Only	05048

NEON

2.0	122	L4	1995	1999	11th Digit Vin is T	05076
2.0	122	L4	1996	2000	Modular Clutch Includes Flywheel	05085
2.0	122	L4	2001	2001	Modular Clutch Includes Flywheel	05085

RELIANT

2.2	134	L4	1981	1983	Sold As Kit Only	05028A
2.2	134	L4	1986	1988	Sold As Kit Only	05028A

SAPORO

1.6	98	L4	1978	1979	—	05020
2.6	159	L4	1978	1983	—	05041

SUNDANCE

2.2	134	L4	1987	1989	Non-Turbo, Sold As Kit Only	05048
2.2	134	L4	1990	1990	Non-Turbo	05061
2.2	134	L4	1991	1994	Non-Turbo	05059

2 PLYMOUTH LIGH TRUCK, SUV & VAN

ARROW PICKUP

2.0	122	L4	1979	1980	—	05012
2.0	122	L4	1981	1982	—	05011
2.6	159	L4	1979	1982	—	05041

TRAILDUSTER

3.7	226	L6	1975	1980	11" Disc	05016
5.2	317	V8	1974	1981	10-3/8" Disc	05029
5.2	317	V8	1974	1981	11" Disc	05016
5.9	360	V8	1974	1981	—	05016

VOYAGER

2.6	159	L4	1984	1986	—	05052
-----	-----	----	------	------	---	-------

PONTIAC

6000

2.5	153	L4	1984	1984	—	04077
2.5	153	L4	1987	1988	—	04088
2.8	171	V6	1986	1986	—	04088
2.8	171	V6	1987	1988	—	04088

BONNEVILLE, CATALINA, CHIEFTAN, EXECUTIVE, GRAND PRIX, GRANDVILLE

2.8	171	V6	1988	1988	FWD	04088
2.8	171	V6	1989	1989	FWD	04088
3.1	189	V6	1989	1990	Turbo, FWD	04116
3.1	189	V6	1989	1992	FWD	04116
6.4	391	V8	1959	1960	12" Diaph Clutch	04064
6.4	391	V8	1964	1964	4 BBL	04021
6.4	391	V8	1965	1966	4 BBL	04049
6.6	403	V8	1967	1970	11" Disc	04049
6.6	403	V8	1970	1970	10-3/8" Disc	04021
6.6	403	V8	1971	1972	3 Spd	04021
6.6	403	V8	1971	1972	4 Spd	04019
6.6	403	V8	1971	1972	4 Spd	04019
7.0	427	V8	1967	1969	—	04049
7.5	458	V8	1970	1971	3 Spd	04049
7.5	458	V8	1971	1972	4 Spd	04020

EXEDY OEM	Disc (mm)	Disc (in)	Spline Dia	Splines	Master Cylinder	Slave Cylinder	Clutch Cable	Clutch Fork	New Flywheel
Y	225	8-7/8	7/8	20	MC179	SC587	—	—	—
Y	225	8-7/8	7/8	20	MC529	SC820	—	—	—
Y	225	8-7/8	7/8	20	MC180	SC586	—	—	—
Y	225	8-7/8	7/8	20	MC180	SC587	—	—	—
Y	225	8-7/8	7/8	20	MC179	SC587	—	—	—
Y	215	8-1/2	7/8	20	MC180	SC581	—	—	—
Y	225	8-7/8	7/8	20	MC180	SC586	—	—	—
Y	225	8-7/8	7/8	20	MC180	SC587	—	—	—
—	230	9-1/16	15/16	17	—	—	—	—	—
—	230	9-1/16	15/16	17	—	—	—	—	—
—	230	9-1/16	15/16	17	MC346	SC790	—	—	—
—	215	8-7/16	13/16	18	—	—	—	—	—
—	215	8-7/16	13/16	18	—	—	—	—	—
—	200	7-7/8	7/8	20	—	—	—	—	—
Y	225	8-7/8	1-1/32	23	—	—	—	—	—
Y	225	8-7/8	7/8	20	—	—	—	—	—
—	215	8-7/16	13/16	18	—	—	—	—	—
—	215	8-7/16	13/16	17	—	—	—	—	—
—	215	8-7/16	7/8	20	—	—	—	—	—
Y	215	8-7/16	7/8	23	—	—	—	—	—
Y	225	8-7/8	1-1/32	23	—	—	CC216	—	—
—	280	11	1	23	—	—	—	—	—
—	263	10-3/8	1	23	—	—	—	—	—
—	280	11	1	23	—	—	—	—	—
—	280	11	1	23	—	—	—	—	—
Y	225	8-7/8	1-1/32	23	—	—	—	—	—
—	225	8-7/8	15/16	14	—	—	—	—	—
Y	225	8-7/8	15/16	14	MC319	—	—	—	FWGM111
Y	225	8-7/8	15/16	14	MC319	—	—	—	FWGM111
Y	225	8-7/8	15/16	14	MC319	SC714	—	—	FWGM111
Y	225	8-7/8	15/16	14	MC322	SC715	—	—	FWGM111
Y	225	8-7/8	15/16	14	MC322	SC715	—	—	—
—	225	8-7/8	15/16	14	MC322	SC715	—	—	—
—	225	8-7/8	15/16	14	MC322	SC715	—	—	—
—	300	11-3/4	1-1/8	10	—	—	—	—	—
—	265	10-1/2	1-1/8	10	—	—	—	—	—
—	280	11	1-1/8	10	—	—	—	—	—
—	280	11	1-1/8	10	—	—	—	—	—
—	265	10-1/2	1-1/8	10	—	—	—	—	FWGM101
—	265	10-1/2	1-1/8	10	—	—	—	—	—
—	263	10-3/8	1-1/8	10	—	—	—	—	FWGM101
—	263	10-3/8	1-1/8	26	—	—	—	—	FWGM101
—	280	11	1-1/8	10	—	—	—	—	—
—	280	11	1-1/8	10	—	—	—	—	—
—	280	11	1-1/8	26	—	—	—	—	—

2

Liter	CC/IN	Cyl	Years		Application Information	Kit
			To	From		
PONTIAC continued						
<i>FIERO</i>						
2.5	153	L4	1985	1985	—	04005
2.5	153	L4	1986	1988	—	04005
2.8	171	V6	1985	1985	4 Spd	04077
2.8	171	V6	1985	1985	4 Spd	04077
2.8	171	V6	1986	1986	4 Spd	04077
2.8	171	V6	1986	1988	5 Spd	04088
<i>FIREBIRD, TRANS AM</i>						
2.5	153	L4	1982	1982	—	04052
2.5	153	L4	1983	1983	Non Pre-Damped	04053
2.5	153	L4	1983	1986	Pre-Damped	04129
2.5	153	L4	1984	1986	Non Pre-Damped	04053
2.8	171	V6	1985	1987	Non Pre-Damped	04053
2.8	171	V6	1985	1987	Pre-Damped	04129
2.8	171	V6	1988	1988	Non Pre-Damped	04053
2.8	171	V6	1988	1988	Pre-Damped	04129
2.8	171	V6	1989	1989	Non Pre-Damped	04053
2.8	171	V6	1989	1989	Pre-Damped	04129
3.1	189	V6	1990	1992	Non Pre-Damped	04053
3.1	189	V6	1990	1992	Pre-Damped	04129
3.4	207	V6	1993	1994	—	04133
3.4	207	V6	1995	1995	With Pushrod CV601A	04133
3.4	207	V6	1995	1995	With Pushrod H603A	04133
3.8	232	L6	1967	1967	2 BBL	04021
3.8	232	V6	1979	1980	—	04021
3.8	232	V6	1980	1981	—	04021
3.8	232	V6	1996	2002	—	04082
4.9	299	V8	1977	1977	—	04021
4.9	299	V8	1979	1979	—	04019
4.9	299	V8	1980	1980	—	04021
4.9	299	V8	1980	1980	Turbo	04021
5.0	305	V8	1979	1981	—	04021
5.0	305	V8	1981	1981	26 Spline Disc	04019
5.0	305	V8	1981	1981	26 Spline Disc, California Emission	04020
5.0	305	V8	1982	1982	10 Spline Disc	04021
5.0	305	V8	1982	1982	26 Spline Disc	04019
5.0	305	V8	1983	1983	—	04019
5.0	305	V8	1984	1985	—	04019
5.0	305	V8	1986	1992	—	04019
5.3	323	V8	1967	1967	—	04021
5.7	348	V8	1969	1971	High Output Engine	04021
5.7	348	V8	1975	1975	4 Speed	04019
5.7	348	V8	1976	1977	4 Speed	04019
5.7	348	V8	1978	1978	—	04021
5.7	348	V8	1987	1992	—	04019
5.7	348	V8	1998	2002	Modular Clutch Includes Flywheel	04173
6.6	403	V8	1967	1968	—	04021
6.6	403	V8	1971	1972	3 Spd, Ram Air	04021
6.6	403	V8	1971	1974	4 Spd, 2 BBL	04019
6.6	403	V8	1975	1977	4BBL	04019
6.6	403	V8	1978	1979	—	04020
7.5	458	V8	1973	1976	—	04020

2

EXEDY OEM	Disc (mm)	Disc (in)	Spline Dia	Splines	Master Cylinder	Slave Cylinder	Clutch Cable	Clutch Fork	New Flywheel
Y	215	8-1/2	1	14	MC531	SC829	—	—	—
Y	215	8-1/2	1	14	—	SC829	—	—	—
—	225	8-7/8	15/16	14	—	SC829	—	—	FWGM111
—	225	8-7/8	15/16	14	MC531	—	—	—	FWGM111
—	225	8-7/8	15/16	14	—	—	—	—	FWGM111
Y	225	8-7/8	15/16	14	—	—	—	—	FWGM111
—	232	9-1/8	1-1/8	10	—	—	—	—	—
—	225	8-7/8	15/16	14	—	—	—	—	—
—	232	9-1/8	1	14	MC315	SC787	—	—	—
—	225	8-7/8	15/16	14	MC315	SC787	—	—	—
—	225	8-7/8	15/16	14	MC320	SC787	—	CF129	FWGM111
—	232	9-1/8	1	14	MC320	SC787	—	CF129	FWGM111
—	225	8-7/8	15/16	14	MC320	SC787	—	—	FWGM111
—	232	9-1/8	1	14	MC320	SC787	—	—	FWGM111
—	225	8-7/8	15/16	14	MC320	SC787	—	—	—
—	232	9-1/8	1	14	MC320	SC787	—	—	—
—	225	8-7/8	15/16	14	MC320	SC787	—	CF129	—
—	232	9-1/8	1	14	MC320	SC787	—	CF129	—
—	246	9-5/8	1-1/8	26	MC331	SC719	—	—	—
—	246	9-5/8	1-1/8	26	MC331	SC719	—	—	—
—	246	9-5/8	1-1/8	26	MC334	SC719	—	—	—
—	265	10-1/2	1-1/8	10	—	—	—	—	—
—	265	10-1/2	1-1/8	10	—	—	—	—	—
—	265	10-1/2	1-1/8	10	—	—	—	CF100	—
Y	246	9-5/8	1-1/8	26	MC334	SC746	—	—	—
—	265	10-1/2	1-1/8	10	—	—	—	—	—
—	263	10-3/8	1-1/8	26	—	—	—	—	—
—	265	10-1/2	1-1/8	10	—	—	—	—	—
—	265	10-1/2	1-1/8	10	—	—	—	—	—
—	265	10-1/2	1-1/8	10	—	—	—	CF100	FWGM101
—	263	10-3/8	1-1/8	26	—	—	—	CF100	FWGM101
—	280	11	1-1/8	26	—	—	—	CF100	—
—	265	10-1/2	1-1/8	10	—	—	—	—	FWGM101
—	263	10-3/8	1-1/8	26	—	—	—	—	FWGM101
—	263	10-3/8	1-1/8	26	—	—	—	CF133	FWGM101
—	263	10-3/8	1-1/8	26	MC315	SC787	—	CF133	FWGM101
—	263	10-3/8	1-1/8	26	MC315	SC787	—	CF133	FWGM112
—	265	10-1/2	1-1/8	10	—	—	—	—	—
—	265	10-1/2	1-1/8	10	—	—	—	—	—
—	263	10-3/8	1-1/8	26	—	—	—	—	—
—	263	10-3/8	1-1/8	26	—	—	—	CF100	—
—	265	10-1/2	1-1/8	10	—	—	—	CF100	—
—	263	10-3/8	1-1/8	26	—	—	—	—	—
—	300	11-3/4	1-1/8	26	MC334	SC746	—	—	—
—	265	10-1/2	1-1/8	10	—	—	—	—	—
—	265	10-1/2	1-1/8	10	—	—	—	—	—
—	263	10-3/8	1-1/8	26	—	—	—	—	—
—	263	10-3/8	1-1/8	26	—	—	—	—	—
—	280	11	1-1/8	26	—	—	—	—	—
—	280	11	1-1/8	26	—	—	—	—	—

2

Liter	CC/IN	Cyl	Years		Application Information	Kit
			To	From		
PONTIAC continued						
<i>FIREFLY (CANADA)</i>						
1.0	61	L3	1985	1988	Non-Turbo	04104
1.0	61	L3	1987	1990	Turbo	04100
1.0	61	L3	1989	1991	Non-Turbo	04124
G5						
2.2	134	L4	2007	2008	Includes Slave Cylinder, Sold As Kit Only	GMK1010
2.4	146	L4	2007	2008	Includes Slave Cylinder, Sold As Kit Only	GMK1010
<i>GRAND AM, GRAND SAFARI, LA MANS, TEMPEST, VENTURA</i>						
2.2	134	L4	2002	2004	Includes Slave Cylinder, Sold As Kit Only	GMK1000
2.3	140	L4	1989	1991	Quad 4, 8th Digit of VIN Is A, Includes Slave Cylinder	04088
2.3	140	L4	1992	1992	Quad 4, 8th Digit of VIN Is A, Includes Slave Cylinder	04088
2.3	140	L4	1992	1992	With External Slave Cylinder	04088
2.3	140	L4	1993	1994	8th Digit of VIN is 3, SOHC	04135
2.3	140	L4	1993	1994	Quad 4, 8th Digit in VIN Is A, Includes Slave Cylinder	04136
2.3	140	L4	1995	1995	—	04162
2.4	146	L4	1996	1998	Includes Slave Cylinder	04162
2.4	146	L4	2000	2001	Includes Slave Cylinder, Sold As Kit Only	KGM04
2.5	153	L4	1977	1985	—	04005
2.5	153	L4	1986	1986	—	04005
2.5	153	L4	1987	1991	—	04005
3.8	232	L6	1966	1967	—	04021
3.8	232	V6	1979	1979	—	04021
4.1	250	L6	1968	1969	2 BBL	04021
4.9	299	V8	1979	1979	—	04021
5.7	348	V8	1968	1969	4 BBL	04021
5.7	348	V8	1975	1975	3 Spd, 4 BBL 26 SPLINE	04019
5.7	348	V8	1975	1976	2BBL	04019
5.7	348	V8	1975	1977	3 Spd, 4 BBL	04019
6.4	391	V8	1964	1964	4 BBL	04021
6.4	391	V8	1965	1965	11" Disc	04049
<i>GRAND AM, GRAND SAFARI, LA MANS, TEMPEST, VENTURA continued</i>						
6.6	403	V8	1968	1972	4 Spd, 2 BBL	04021
6.6	403	V8	1973	1977	4 Spd, 4 BBL	04019
6.6	403	V8	1975	1975	3 Speed	04019
6.6	403	V8	1976	1976	2BBL	04019
6.6	403	V8	1977	1977	4 Spd, 4 BBL	04019
7.5	458	V8	1970	1971	3 Spd, 4 BBL	04049
7.5	458	V8	1971	1973	4 Spd	04020
GTO						
5.7	348	V8	1970	1970	—	04021
5.7	348	V8	2004	2004	Modular Clutch Includes Flywheel	04173
6.4	391	V8	1964	1966	—	04021
6.6	403	V8	1967	1970	—	04021
6.6	403	V8	1971	1971	4 Spd, 4 BBL 26 SPLINE	04019
6.6	403	V8	1971	1973	10 SPLINE	04021
6.6	403	V8	1972	1973	26 SPLINE	04019
7.5	458	V8	1970	1970	3 Spd, 4 BBL	04049
7.5	458	V8	1971	1973	4 Spd	04020
<i>J2000, SUNBIRD, SUNFIRE</i>						
1.8	110	L4	1982	1982	Optional 9-1/8" Disc	04077
1.8	110	L4	1983	1983	4 Spd	04094
1.8	110	L4	1983	1984	5 Spd, Non-Turbo	04046
1.8	110	L4	1985	1986	5 Spd, Non-Turbo	04046
2.0	122	L4	1983	1983	5 Spd, with Optional 9-1/8" Disc	04077
2.0	122	L4	1983	1984	5 Spd with Standard 8-1/2" Disc	04005
2.0	122	L4	1984	1986	5 Speed, with Optional 9-1/8" Disc	04077
2.0	122	L4	1985	1985	5 Spd with Standard 8-1/2" Disc	04005
2.0	122	L4	1987	1988	Non-Turbo	04046

2

EXEDY OEM	Disc (mm)	Disc (in)	Spline Dia	Splines	Master Cylinder	Slave Cylinder	Clutch Cable	Clutch Fork	New Flywheel
Y	190	7-1/2	15/16	20	—	—	—	—	—
Y	190	7-1/2	3/4	18	—	—	—	—	—
Y	170	6-11/16	3/4	18	—	—	—	—	—
Y	225	8-7/8	15/16	14	—	—	—	—	—
Y	225	8-7/8	15/16	14	—	—	—	—	—
Y	225	8-7/8	1	14	—	—	—	—	—
Y	225	8-7/8	15/16	14	MC325	SC715	—	—	—
Y	225	8-7/8	15/16	14	MC330	SC715	—	—	—
Y	225	8-7/8	15/16	14	MC330	SC715	—	—	—
Y	225	8-7/8	15/16	14	MC325	SC715	—	—	—
Y	225	8-7/8	15/16	14	MC330	—	—	—	—
Y	225	8-7/8	15/16	14	MC330	SC715	—	—	—
Y	225	8-7/8	15/16	14	MC330	SC715	—	—	—
Y	225	8-7/8	1	14	—	—	—	—	—
Y	215	8-1/2	1	14	—	SC714	—	—	—
Y	215	8-1/2	1	14	MC328	SC714	—	—	—
Y	215	8-1/2	1	14	MC317	SC714	—	CF134	—
—	265	10-1/2	1-1/8	10	—	—	—	—	—
—	265	10-1/2	1-1/8	10	—	—	—	—	—
—	265	10-1/2	1-1/8	10	—	—	—	—	—
—	265	10-1/2	1-1/8	10	—	—	—	—	—
—	265	10-1/2	1-1/8	10	—	—	—	—	FWGM101
—	263	10-3/8	1-1/8	26	—	—	—	—	FWGM101
—	263	10-3/8	1-1/8	26	—	—	—	—	FWGM101
—	263	10-3/8	1-1/8	26	—	—	—	—	FWGM101
—	265	10-1/2	1-1/8	10	—	—	—	—	—
—	280	11	1-1/8	10	—	—	—	—	—
—	265	10-1/2	1-1/8	10	—	—	—	—	FWGM101
—	263	10-3/8	1-1/8	26	—	—	—	—	FWGM101
—	263	10-3/8	1-1/8	26	—	—	—	—	FWGM101
—	263	10-3/8	1-1/8	26	—	—	—	—	FWGM101
—	263	10-3/8	1-1/8	26	—	—	—	—	FWGM101
—	280	11	1-1/8	10	—	—	—	—	—
—	280	11	1-1/8	26	—	—	—	—	—
—	265	10-1/2	1-1/8	10	—	—	—	—	FWGM101
—	300	11-3/4	1-1/8	26	—	—	—	—	—
—	265	10-1/2	1-1/8	10	—	—	—	—	—
—	265	10-1/2	1-1/8	10	—	—	—	—	FWGM101
—	263	10-3/8	1-1/8	26	—	—	—	—	FWGM101
—	265	10-1/2	1-1/8	10	—	—	—	—	FWGM101
—	263	10-3/8	1-1/8	26	—	—	—	—	FWGM101
—	280	11	1-1/8	10	—	—	—	—	—
—	280	11	1-1/8	26	—	—	—	—	—
—	225	8-7/8	15/16	14	—	—	—	—	—
—	215	8-1/2	1	14	—	—	—	—	—
—	215	8-1/2	1	14	—	—	—	—	—
—	215	8-1/2	1	14	MC318	SC714	—	—	—
—	225	8-7/8	15/16	14	MC318	SC714	—	—	—
Y	215	8-1/2	1	14	—	—	—	—	FWGM10
—	225	8-7/8	15/16	14	MC318	SC714	—	—	—
Y	215	8-1/2	1	14	—	SC714	—	—	FWGM10
—	215	8-1/2	1	14	MC316	SC714	—	—	FWGM10

2

Liter	CC/IN	Cyl	Years		Application Information	Kit
			To	From		
PONTIAC continued						
<i>J2000, SUNBIRD, SUNFIRE</i>						
2.0	122	L4	1989	1991	Non-Turbo	04046
2.0	122	L4	1992	1994	—	04046
2.2	134	L4	1995	1996	Includes Slave Cylinder	04161
2.2	134	L4	1997	1999	Includes Slave Cylinder	04161
2.2	134	L4	2000	2002	Includes Slave Cylinder, Sold As Kit Only	KGM08
2.2	134	L4	2002	2005	SFI with VIN F, Includes Slave Cylinder, Sold As Kit Only	GMK1000
2.3	140	L4	1995	1995	Includes Slave Cylinder	04158
2.4	146	L4	1996	1999	Includes Slave Cylinder	04158
2.4	146	L4	2000	2002	Includes Slave Cylinder, Sold As Kit Only	KGM04
3.1	189	V6	1991	1992	—	04088
3.1	189	V6	1993	1994	Includes Slave Cylinder	04132
3.8	232	V6	1979	1980	—	04021
<i>PHOENIX</i>						
2.5	153	L4	1980	1984	—	04077
2.8	171	V6	1980	1981	—	04077
2.8	171	V6	1982	1984	—	04077
3.8	232	V6	1979	1979	—	04021
5.0	305	V8	1979	1979	—	04021
<i>T1000</i>						
1.6	98	L4	1981	1981	—	04057
<i>VIBE</i>						
1.8	110	L4	2003	2008	5 Speed	KTY03
1.8	110	L4	2003	2006	GT, DOHC with 6 Spd	KTY14
PORSCHE						
<i>911</i>						
2.0	1991	H6	1965	1969	Sold As Kit Only	KPO02
2.2	2195	H6	1970	1971	Sold As Kit Only	KPO05
3.2	3163	H6	1987	1989	Carrera, Sold As Kit Only	KPO03
3.2	3163	H6	1989	1989	Speedster, Sold As Kit Only	KPO03
3.3	3294	H6	1987	1988	Turbo with 930 Transmission, Sold As Kit Only	KPO15
3.3	3294	H6	1991	1992	Turbo, Sold As Kit Only	KPO12
3.6	3606	H6	1990	1993	Carrera, Sold As Kit Only	KPO12
3.6	3606	H6	1990	1994	Carrera 4, Sold As Kit Only	KPO12
3.6	3606	H6	1992	1994	Turbo Look, Sold As Kit Only	KPO12
3.6	3606	H6	1993	1993	Carrera 4, Turbo Look, Sold As Kit Only	KPO12
3.6	3606	H6	1993	1994	RS, Sold As Kit Only	KPO12
3.6	3606	H6	1994	1994	Speedster, Sold As Kit Only	KPO12
3.6	3606	H6	1994	1994	Turbo 3.6, Sold As Kit Only	KPO12
3.6	3606	H6	1996	1997	Turbo, Sold As Kit Only	KPO12
3.6	3596	H6	2002	2003	Carrera 4, Sold As Kit Only	KPO18
3.6	3606	H6	2002	2003	6 Spd Turbo, Sold as Kit Only	POK1001
3.6	3606	H6	2002	2005	Turbo, Sold as Kit Only	POK1000
3.6	3596	H6	2003	2003	Carrera 2, Sold As Kit Only	KPO18
3.6	3606	H6	2004	2004	GT3, Sold As Kit Only	KPO12
3.6	3596	H6	2004	2005	Sold as Kit Only	POK1003
3.6	3606	H6	2005	2005	6 Spd Turbo, Sold as Kit Only	POK1001
3.6	3596	H6	2007	2007	Turbo, Sold as Kit Only	POK1002
<i>912</i>						
1.6	1582	H4	1965	1969	Sold As Kit Only	KPO04
2.0	1991	H6	1971	1971	Sold As Kit Only	KPO16
2.0	1971	H4	1974	1975	Sold As Kit Only	KPO16
2.0	1967	H4	1976	1976	Sold As Kit Only	KPO16
<i>924</i>						
2.0	1983	L4	1977	1982	Sold As Kit Only	KPO17
<i>928</i>						
5.0	4950	V8	1985	1991	GT, S, S4, Sold As Kit Only	KPO06

EXEDY OEM	Disc (mm)	Disc (in)	Spline Dia	Splines	Master Cylinder	Slave Cylinder	Clutch Cable	Clutch Fork	New Flywheel
—	215	8-1/2	1	14	MC327	SC714	—	—	FWGM10
—	215	8-1/2	1	14	MC327	SC714	—	—	FWGM10
Y	215	8-1/2	1	14	MC333	SC715	—	—	FWGM10
Y	215	8-1/2	1	14	MC333	SC715	—	—	—
Y	215	8-1/2	1	14	MC333	—	—	—	—
Y	225	8-7/8	1	14	—	—	—	—	—
Y	225	8-7/8	15/16	14	MC333	SC715	—	—	—
Y	225	8-7/8	15/16	14	MC333	SC715	—	—	—
Y	225	8-7/8	1	14	—	—	—	—	—
Y	225	8-7/8	15/16	14	MC327	SC715	—	—	—
—	225	8-7/8	15/16	14	MC330	SC715	—	—	—
—	265	10-1/2	1-1/8	10	—	—	—	—	—
—	225	8-7/8	15/16	14	—	—	—	—	—
—	225	8-7/8	15/16	14	—	—	—	—	—
—	225	8-7/8	15/16	14	—	—	—	—	FWGM111
—	265	10-1/2	1-1/8	10	—	—	—	—	—
—	265	10-1/2	1-1/8	10	—	—	—	—	—
—	184	7-1/4	1	14	—	—	—	—	—
—	210	8-1/4	1	21	MC524	SC873	—	—	—
Y	210	8-1/4	1	21	MC524	SC873	—	—	TYF513
—	215	8-1/2	13/16	24	—	—	—	—	—
—	225	8-7/8	13/16	24	—	—	—	—	—
—	240	9-1/2	1-1/32	23	—	—	—	—	—
—	240	9-1/2	1-1/32	23	—	—	—	—	—
—	240	9-1/2	1	23	—	—	—	—	—
—	240	9-1/2	1-1/32	23	—	—	—	—	—
—	240	9-1/2	1-1/32	23	—	—	—	—	—
—	240	9-1/2	1-1/32	23	—	—	—	—	—
—	240	9-1/2	1-1/32	23	—	—	—	—	—
—	240	9-1/2	1-1/32	23	—	—	—	—	—
—	240	9-1/2	1-1/32	23	—	—	—	—	—
—	240	9-1/2	1-1/32	23	—	—	—	—	—
—	240	9-1/2	1-1/32	23	—	—	—	—	—
—	240	9-1/2	1-1/32	23	—	—	—	—	—
—	240	9-1/2	15/16	23	—	—	—	—	—
—	240	9-7/16	1-1/16	23	—	—	—	—	—
—	240	9-7/16	1-1/16	23	—	—	—	—	—
—	240	9-1/2	15/16	23	—	—	—	—	—
—	240	9-1/2	1-1/32	23	—	—	—	—	—
—	240	9-7/16	1-1/16	23	—	—	—	—	—
—	240	9-7/16	1-1/16	23	—	—	—	—	—
—	240	9-7/16	1-1/16	23	—	—	—	—	—
—	200	7-7/8	13/16	24	—	—	—	—	—
—	215	8-1/2	13/16	24	—	—	—	—	—
—	215	8-1/2	13/16	24	—	—	—	—	—
—	215	8-1/2	13/16	24	—	—	—	—	—
—	215	8-1/2	13/16	24	—	—	—	—	—
—	250	9-7/8	1-1/32	23	—	—	—	—	—

Liter	CC/IN	Cyl	Years		Application Information	Kit
			To	From		
PORSCHE continued						
930						
3.3	3294	H6	1978	1979	Turbo, Sold As Kit Only	KPO15
944						
2.5	2475	L4	1986	1989	Turbo, Sold As Kit Only	KPO01
2.5	2475	L4	1987	1988	S, Sold As Kit Only	KPO07
3.0	2999	L4	1989	1989	S, Sold As Kit Only	KPO07
3.0	2983	L4	1990	1991	S, Sold As Kit Only	KPO07
BOXSTER						
3.2	3179	H6	2000	2006	Sold As Kit Only	KPO18
RENAULT						
FUEGO						
1.6	1565	L4	1982	1984	Turbo	14009
2.2	2152	L4	1984	1985	—	14009
R17						
1.6	1647	L4	1972	1976	R1313, R1317, R1318, R1323, R1327, R1328	14008
R18						
2.2	2152	L4	1984	1986	R18i	14009
SAAB						
9-2X						
2.0	1994	H4	2005	2005	WAD Type Disc	KSB03
2.0	1994	H4	2005	2005	Economy version	FJK1006
2.5	2458	H4	2005	2005	—	KSB04
2.5	2458	H4	2006	2006	Turbo, Sold as Kit Only	FJK1001
2.5	2458	H4	2006	2006	Turbo, Sold As Kit Only, Push Type Clutch, Includes FW	FJK1001FW
9-3						
2.0	1985	L4	1999	2001	Turbo, Sold As Kit Only	SBK1000
2.3	2290	L4	2002	2002	Turbo, Sold As Kit Only, Includes Slave Cylinder	KSA04
9-5						
2.3	2290	L4	1999	2003	Turbo, Sold As Kit Only, Includes Slave Cylinder	KSA04
2.3	2290	L4	2004	2004	Sold as Kit Only, Includes Slave Cylinder	KSA04
3.0	2961	V6	2002	2002	Sold as Kit Only, Includes Slave Cylinder	KSA04
900						
2.0	1985	L4	1979	1990	—	21006
2.0	1985	L4	1979	1993	Turbo	21006
2.0	1985	L4	1994	1998	Turbo	21006
2.1	2119	L4	1994	1994	Sold As Kit Only	21006
2.3	2290	L4	1994	1994	Sold As Kit Only, to eng. # R129242	KSA01
2.3	2290	L4	1994	1998	—	KSA03
2.5	2498	V6	1994	1995	Sold As Kit Only	KSA02
9000						
2.0	1985	L4	1987	1989	—	21007
2.3	2290	L4	1990	1993	—	21007
2.3	2290	L4	1994	1994	Turbo, Sold As Kit Only	KSA05
2.3	2290	L4	1995	1998	Turbo, Sold As Kit Only	KSA05
3.0	2961	V6	1995	1997	Sold As Kit Only	KSA05
99						
2.0	1985	L4	1976	1980	—	21006
2.0	1985	L4	1978	1978	Turbo	21006

2

EXEDY OEM	Disc (mm)	Disc (in)	Spline Dia	Splines	Master Cylinder	Slave Cylinder	Clutch Cable	Clutch Fork	New Flywheel
—	240	9-1/2	1	23	—	—	—	—	—
—	240	9-1/2	1-1/32	23	—	—	—	—	—
—	225	8-7/8	1-1/32	24	—	—	—	—	—
—	225	8-7/8	1-1/32	24	—	—	—	—	—
—	225	8-7/8	1-1/32	24	—	—	—	—	—
—	240	9-1/2	15/16	23	—	—	—	—	—
—	215	8-1/2	15/16	21	—	—	—	—	—
—	215	8-1/2	15/16	21	—	—	—	—	—
—	215	8-1/2	15/16	21	—	—	—	—	—
—	215	8-1/2	15/16	21	—	—	—	—	—
Y	230	9-1/16	1	24	—	—	—	—	—
Y	228	9	1	24	—	—	—	—	—
Y	225	8-7/8	1	24	—	—	—	—	—
Y	230	9-1/16	1	24	MC585	SC919	—	—	—
Y	230	9-1/16	1	24	MC585	SC919	—	—	—
—	228	9	1	14	—	—	—	—	—
—	228	9	1	14	—	—	—	—	—
—	228	9	1	14	—	—	—	—	—
—	228	9	1	14	—	—	—	—	—
—	228	9	1	14	—	—	—	—	—
—	215	8-7/16	3/4	17	MC130	SC531	—	—	—
—	215	8-7/16	3/4	17	MC130	SC531	—	—	—
—	215	8-7/16	3/4	17	—	—	—	—	—
—	215	8-7/16	3/4	17	—	—	—	—	—
—	228	9	1	14	—	—	—	—	—
—	—	—	—	—	—	—	—	—	—
—	228	9	1	14	—	—	—	—	—
—	215	8-7/16	3/4	17	—	—	—	—	—
—	215	8-7/16	3/4	17	—	—	—	—	—
—	228	9	1	14	—	—	—	—	—
—	228	9	1	14	—	—	—	—	—
—	228	9	1	14	—	—	—	—	—
—	215	8-7/16	3/4	17	MC130	SC531	—	—	—
—	215	8-7/16	3/4	17	MC130	SC531	—	—	—

2

Liter	CC/IN	Cyl	Years		Application Information	Kit
			To	From		
SATURN						
<i>ION</i>						
2.0	122	L4	2004	2007	Supercharged, Includes CSC Hydraulic Slave, Sold as Kit Only	GMK1016
2.2	134	L4	2003	2007	Includes CSC Hydraulic Slave Cylinder	GMK1017
<i>L SERIES</i>						
2.2	134	L4	2000	2003	—	KSN01
<i>S SERIES</i>						
1.9	116	L4	1991	1999	—	04115
1.9	116	L4	2000	2002	—	KSN02
SATURN SUV						
<i>VUE</i>						
2.2	134	L4	2002	2007	Includes CSC Hydraulic Slave Cylinder	KSN03
3.5	3474	V6	2002	2007	Includes CSC Hydraulic Slave Cylinder	KSN03
SCION						
<i>FR-S</i>						
2.0	1994	H4	2013	2016	Sold as Kit Only	FJK1005
<i>TC</i>						
2.4	2398	L4	2005	2010	—	TYK1506
2.5	2398	L4	2011	2015	Sold as Kit Only, Includes CSC Hydraulic Slave Cylinder	TYK1507
<i>XA, XB</i>						
1.5	1497	L4	2004	2005	—	KTY15
1.5	1497	L4	2005	2006	—	KTY15
<i>XB</i>						
2.4	2398	L4	2008	2015	—	TYK1506
SUBARU						
<i>1600, 1800</i>						
1.6	1595	H4	1976	1980	—	15002
1.6	1595	H4	1981	1984	—	15001
1.8	1781	H4	1980	1984	2 WD	15001
1.8	1781	H4	1983	1984	2 WD, Turbo	15001
1.8	1781	H4	1985	1989	2 WD	15001
1.8	1781	H4	1985	1989	2 WD, Turbo	15001
<i>BAJA</i>						
1.6	1595	H4	1978	1980	—	15002
1.8	1781	H4	1980	1980	—	15002
2.5	2458	H4	2003	2006	SOHC, Sold As Kit Only	KSB04
2.5	2458	H4	2004	2005	DOHC, Turbo, WAD Type Disc, Sold As Kit Only	KSB03
2.5	2458	H4	2004	2005	DOHC, Turbo, Economy Version, Sold As Kit Only	FJK1006
2.5	2458	H4	2006	2006	Turbo, Solid FW Replacement for OEM Dual Mass FW, Sold as Kit Only	FJK1001FW
<i>BRAT</i>						
1.8	1781	H4	1981	1982	4WD	15001
1.8	1781	H4	1983	1987	2WD	15001
1.8	1781	H4	1984	1984	2 WD, Turbo	15001
<i>BRZ</i>						
2.0	1994	H4	2013	2018	Sold as Kit Only	FJK1005
<i>IMPREZA, IMPREZA OUTBACK, RS, TS, WRX</i>						
1.8	1781	H4	1993	1993	4 WD	15012
1.8	1781	H4	1993	1994	2 WD	15014
1.8	1781	H4	1994	1994	AWD	15014
1.8	1781	H4	1995	1995	2 WD	KSB02
1.8	1781	H4	1995	1995	4 WD	15010
1.8	1781	H4	1996	1997	—	15010
2.0	1999	H4	2013	2017	Non-Turbo, Sold As Kit Only	KSB04
2.0	1999	H4	2018	—	6 Spd NON-Turbo, Sold as Kit Only	FJK1004
2.2	2212	H4	1995	2001	—	15010

2

EXEDY OEM	Disc (mm)	Disc (in)	Spline Dia	Splines	Master Cylinder	Slave Cylinder	Clutch Cable	Clutch Fork	New Flywheel
—	238	9-3/8	1	14	—	—	—	—	—
—	228	9	1	14	—	—	—	—	—
—	228	9	1	14	—	SC717	—	—	—
—	215	8-7/16	15/16	22	MC329	SC717	—	—	—
—	215	8-7/16	15/16	22	MC454	SC717	—	—	—
—	228	9	1	14	—	—	—	—	—
—	228	9	1	14	—	—	—	—	—
Y	230	9-1/16	1	24	—	—	—	—	TYF001
—	236	9-1/4	1-3/16	21	MC524	SC861	—	—	TYF509
—	225	8-7/8	1-1/32	23	—	BRG0182	—	—	TYF509
—	210	8-1/4	1	21	MC535	SC841	—	—	—
—	210	8-1/4	1	21	MC534	SC841	—	—	—
—	236	9-1/4	1-3/16	21	—	SC907	—	—	TYF509
—	200	7-7/8	3/4	23	—	—	—	—	—
—	200	7-7/8	7/8	21	—	—	—	—	—
—	200	7-7/8	7/8	21	—	—	—	—	—
—	200	7-7/8	7/8	21	—	—	CC892	—	—
—	200	7-7/8	7/8	21	—	—	CC892	—	—
—	200	7-7/8	3/4	23	—	—	—	—	—
—	200	7-7/8	3/4	23	—	—	—	—	—
Y	225	8-7/8	1	24	MC567	SC919	—	—	FWSBL02FF
Y	230	9-1/16	1	24	MC586	SC920	—	—	—
Y	228	9	1	24	MC586	SC920	—	—	—
Y	230	9-1/16	1	24	MC586	—	—	—	TYF001
—	200	7-7/8	7/8	21	—	—	—	—	—
—	200	7-7/8	7/8	21	—	—	—	—	—
—	200	7-7/8	7/8	21	—	—	—	—	—
Y	230	9-1/16	1	24	—	—	—	—	TYF001
—	215	8-1/2	1	24	—	—	—	—	—
—	200	7-7/8	7/8	21	—	—	—	—	—
—	200	7-7/8	7/8	21	—	—	—	—	—
—	200	7-7/8	7/8	21	—	—	—	—	—
Y	225	8-7/8	1	24	—	—	—	—	—
Y	225	8-7/8	1	24	—	—	—	—	—
Y	225	8-7/8	1	24	—	—	—	—	FWSBL02FF
Y	230	9-1/16	1	24	—	—	—	—	—
Y	225	8-7/8	1	24	—	—	—	—	FWSBL01

Liter	CC/IN	Cyl	Years		Application Information	Kit
			To	From		
SUBARU continued						
<i>IMPREZA, IMPREZA OUTBACK, RS, TS, WRX continued</i>						
2.5	2458	H4	1998	1998	—	15015
2.5	2458	H4	1999	1999	Sold As Kit Only	KSB04
2.5	2458	H4	2000	2002	Sold As Kit Only	KSB04
2.5	2458	H4	2002	2004	Sold As Kit Only	KSB04
2.5	2458	H4	2005	2012	Non-Turbo, Sold As Kit Only	KSB04
3.0	3000	H6	2001	2003	Sold As Kit Only	KSB04
JUSTY						
1.2	1189	L3	1987	1990	—	15006
1.2	1189	L3	1991	1991	From 12/1/90	15011
1.2	1189	L3	1991	1991	To 11/30/90	15006
1.2	1189	L3	1992	1994	—	15011
LEGACY, LEGACY OUTBACK						
2.2	2212	H4	1990	1996	Non-Turbo	15010
2.2	2212	H4	1991	1991	Turbo, Sold As Kit Only, Pull Type	KSB01
2.2	2212	H4	1992	1994	Turbo, Sold As Kit Only, Pull Type	KSB01
2.2	2212	H4	1997	1999	Non-Turbo	15010
2.5	2458	H4	1996	1998	Sold As Kit Only	KSB04
2.5	2458	H4	1999	1999	Sold As Kit Only	KSB04
2.5	2458	H4	2000	2002	Sold As Kit Only	KSB04
2.5	2458	H4	2003	2004	Sold As Kit Only	KSB04
2.5	2458	H4	2005	2006	Turbo, Solid FW Replacement for OEM Dual Mass FW, Sold as Kit Only, Includes Solid FW	FJK1001FW
2.5	2458	H4	2005	2009	Sold As Kit Only	KSB04
2.5	2458	H4	2007	2009	5spd Turbo, Solid FW Replacement for OEM Dual Mass FW, Sold as kit only	FJK1001
2.5	2458	H4	2007	2009	6 Spd, Turbo, Pull Type Clutch, Sold as Kit Only	FJK1007
2.5	2458	H4	2007	2008	6 Spd Turbo, Sold as Kit Only, Pull Type	FJK1002
2.5	2458	H4	2010	2012	6Spd Turbo, Solid FW Replacement for OEM Dual Mass FW, Sold as kit only	FJK1001
2.5	2458	H4	2010	2018	6 Spd NON-Turbo, Sold as Kit Only	FJK1004
LOYALE						
1.8	1781	H4	1990	1994	Non-Turbo	15001
STI (Impreza WRX STI)						
2.5	2458	H4	2004	2018	6spd, Turbo, Sold as Kit Only	FJK1000
WRX (Impreza WRX)						
2.0	1994	H4	2002	2003	Turbo, Economy Version, Sold As Kit Only	FJK1006
2.0	1994	H4	2003	2005	Turbo, Sold As Kit Only	KSB03
2.0	1994	H4	2015	2018	6 Speed, Turbo, Sold As Kit Only	FJK1001
2.5	2458	H4	2006	2014	WRX, Turbo, Sold As Kit Only	FJK1001
XT						
1.8	1781	H4	1985	1991	Non-Turbo	15001
SUBARU SUV						
FORESTER						
2.5	2458	H4	1998	1998	Non-Turbo, Sold As Kit Only	KSB04
2.5	2458	H4	1999	2000	Non-Turbo, Sold As Kit Only	KSB04
2.5	2458	H4	2001	2001	Non-Turbo, Sold As Kit Only	KSB04
2.5	2458	H4	2002	2004	Non-Turbo, Sold As Kit Only	KSB04
2.5	2458	H4	2004	2005	Turbo, WAD Type Disc, Sold As Kit Only	KSB03
2.5	2458	H4	2004	2005	Turbo, Economy Version, Sold As Kit Only	FJK1006
2.5	2458	H4	2005	2013	Non-Turbo, Sold As Kit Only	KSB04
2.5	2458	H4	2014	2018	6 Spd NON-Turbo, Sold as Kit Only	FJK1004
2.5	2458	H4	2006	2011	Turbo, Solid FW Replacement for OEM Dual Mass FW, Sold as Kit Only	FJK1001
XV CROSSTREK						
2.0	1999	H4	2013	2017	Non-Turbo, Sold As Kit Only	KSB04
2.0	1999	H4	2017	2018	6 speed, Sold As Kit Only	FJK1004
OUTBACK						
2.5	2458	H4	2005	2006	Turbo, Solid FW Replacement for OEM Dual Mass FW, Sold as Kit Only	FJK1001FW
2.5	2458	H4	2007	2009	5 Spd Turbo, Sold as Kit Only	FJK1001
2.5	2458	H4	2010	2018	Sold As Kit Only	FJK1004

EXEDY OEM	Disc (mm)	Disc (in)	Spline Dia	Splines	Master Cylinder	Slave Cylinder	Clutch Cable	Clutch Fork	New Flywheel
Y	225	8-7/8	1	24	MC582	SC847	—	—	FWSBL01
Y	225	8-7/8	1	24	MC567	SC847	—	—	—
Y	225	8-7/8	1	24	MC567	SC847	—	—	FWSBL02FF
Y	225	8-7/8	1	24	MC584	SC847	—	—	FWSBL02FF
Y	225	8-7/8	1	24	MC585	SC919	—	—	FWSBL02FF
Y	225	8-7/8	1	24	—	—	—	—	—
—	184	7-1/4	3/4	23	—	—	—	—	—
—	184	7-1/4	3/4	23	—	—	—	—	—
—	184	7-1/4	3/4	23	—	—	—	—	—
—	184	7-1/4	3/4	23	—	—	—	—	—
Y	225	8-7/8	1	24	—	—	—	—	FWSBL01
—	225	8-7/8	1	24	MC581	—	—	—	—
—	225	8-7/8	1	24	MC581	SC917	—	—	—
Y	225	8-7/8	1	24	—	—	—	—	—
Y	225	8-7/8	1	24	—	—	—	—	—
Y	225	8-7/8	1	24	MC582	SC847	—	—	FWSBL02FF
Y	225	8-7/8	1	24	MC567	SC847	—	—	FWSBL02FF
Y	225	8-7/8	1	24	MC567	SC919	—	—	FWSBL02FF
Y	230	9-1/16	1	24	MC586	SC921	—	—	TYF001
Y	225	8-7/8	1	24	—	SC919	—	—	FWSBL02FF
Y	230	9-1/16	1	24	MC586	SC921	—	—	TYF001
Y	230	9-1/16	1	24	—	—	—	—	—
Y	240	9-7/16	1	24	MC586	—	—	—	—
Y	230	9-1/16	1	24	—	—	—	—	TYF001
Y	230	9-1/16	1	24	—	—	—	—	—
—	200	7-7/8	7/8	21	—	—	—	—	—
Y	240	9-1/2	1	24	—	—	—	—	—
Y	230	9-1/16	1	24	—	SC920	—	—	—
Y	230	9-1/16	1	24	—	SC918	—	—	—
Y	230	9-1/16	1	24	—	—	—	—	TYF001
Y	230	9-1/16	1	24	—	—	—	—	TYF001
—	200	7-7/8	7/8	21	—	—	—	—	—
Y	225	8-7/8	1	24	MC582	SC847	—	—	—
Y	225	8-7/8	1	24	MC567	SC847	—	—	—
Y	225	8-7/8	1	24	MC567	SC847	—	—	FWSBL02FF
Y	225	8-7/8	1	24	MC585	SC847	—	—	FWSBL02FF
Y	230	9-1/16	1	24	—	SC918	—	—	—
Y	228	9	1	24	—	SC918	—	—	—
Y	225	8-7/8	1	24	MC585	SC919	—	—	—
—	230	9-1/16	1	24	—	—	—	—	—
Y	230	9-1/16	1	24	—	SC921	—	—	TYF001
Y	225	8-7/8	1	24	—	—	—	—	—
Y	230	9-1/16	1	24	—	—	—	—	—
Y	230	9-1/16	1	24	MC586	SC921	—	—	TYF001
Y	230	9-1/16	1	24	—	—	—	—	—
—	230	9-1/16	1	24	—	—	—	—	—

Liter	CC/IN	Cyl	Years		Application Information	Kit
			To	From		
SUZUKI						
<i>AERIO/AERIO SX</i>						
2.0	2000	L4	2003	2003	—	SZK1000
2.3	2290	L4	2004	2007	—	SZK1001
<i>ESTEEM</i>						
1.6	1590	L4	1995	2000	—	04100
1.8	1790	L4	1999	2002	—	SZK1000
<i>FORSA (CANADA)</i>						
1.0	993	L3	1985	1988	Non-Turbo	04076
1.0	993	L3	1987	1988	Turbo	04139
<i>SX4</i>						
2.0	1995	L4	2007	2008	Sold as Kit Only, Includes CSC Hydraulic Slave Cylinder	SZK1003
SUZUKI SUV & VAN						
<i>GRAND VITARA</i>						
2.5	2500	V6	2004	2005	Sold As Kit Only	KSZ03
2.7	2700	V6	2004	2005	—	SZK1002
<i>SAMURAI, SJ410</i>						
1.6	1590	L4	1985	1985	—	04076
1.3	1325	L4	1986	1995	—	04104
<i>SIDEKICK</i>						
1.3	1325	L4	1989	1989	—	04104
1.6	1590	L4	1989	1991	2 Door	04108
1.6	1590	L4	1991	1991	4 Door	04137
1.6	1590	L4	1992	1998	—	04137
1.8	1840	L4	1996	1998	—	04137
<i>SJ410 (CANADA)</i>						
1.0	993	L3	1982	1984	—	KSZ02
<i>SWIFT</i>						
1.3	1298	L4	1989	2001	—	04100
<i>X-90</i>						
1.6	1590	L4	1996	1998	—	04137
TOYOTA						
<i>CAMRY</i>						
1.8	1839	L4	1984	1986	Turbo Diesel	16047
2.0	1995	L4	1983	1985	—	16047
2.0	1974	L4	1986	1986	Turbo Diesel, From 8/86	16047
2.0	1974	L4	1986	1986	Turbo Diesel, To 7/86	16047
2.0	1995	L4	1986	1986	From 8/86	16047
2.0	1995	L4	1986	1986	To 7/86	16047
2.0	1998	L4	1987	1989	—	16047
2.0	1998	L4	1988	1991	ALL TRAC	16082
2.0	1998	L4	1990	1990	To 4/30/90	16047
2.0	1998	L4	1991	1991	—	16073
2.2	2164	L4	1992	1996	—	16073
2.2	2164	L4	1997	2001	—	16073
2.4	2362	L4	2002	2006	—	TYK1506
2.4	2362	L4	2007	2009	Sold as Kit Only	TYK1506
2.5	2494	L4	2010	2011	Sold as Kit Only, Includes CSC Hydraulic Slave Cylinder	TYK1507
2.5	2508	V6	1988	1991	—	16082
3.0	2959	V6	1992	1994	—	16062
3.0	2995	V6	1997	2001	—	16062
3.0	2995	V6	2004	2006	Sold as Kit Only	TYK1506
3.3	3275	V6	2004	2006	Sold as Kit Only	TYK1506
3.5	3498	V6	2007	2009	Sold as Kit Only	TYK1506

2

EXEDY OEM	Disc (mm)	Disc (in)	Spline Dia	Splines	Master Cylinder	Slave Cylinder	Clutch Cable	Clutch Fork	New Flywheel
Y	200	7-7/8	7/8	20	MC510	SC869	—	—	—
—	215	8-7/16	7/8	20	MC510	SC869	—	—	—
Y	190	7-1/2	3/4	18	—	—	—	—	—
Y	200	7-7/8	7/8	20	MC533	SC869	—	—	—
Y	160	6-5/16	3/4	18	—	—	—	—	—
Y	190	7-1/2	3/4	18	—	—	—	—	—
Y	215	8-1/2	7/8	20	—	—	—	—	—
—	225	8-7/8	1-13/16	21	MC503	SC870	—	—	—
—	236	9-1/4	1-3/16	21	MC503	—	—	—	—
Y	160	6-5/16	3/4	18	—	—	—	—	—
Y	190	7-1/2	15/16	20	—	—	CC414	—	SZF500
Y	190	7-1/2	15/16	20	—	—	CC809	—	SZF500
Y	200	7-7/8	7/8	20	—	—	CC809	—	—
Y	215	8-7/16	7/8	20	—	—	CC809	—	SZF501
Y	215	8-7/16	7/8	20	—	—	—	—	SZF501
Y	215	8-7/16	7/8	20	MC533	—	—	—	—
—	180	7-1/8	3/4	18	—	—	—	—	—
Y	190	7-1/2	3/4	18	—	—	—	—	—
Y	215	8-7/16	7/8	20	—	—	—	—	SZF501
—	225	8-7/8	1-1/8	20	MC246	SC670	—	—	—
—	225	8-7/8	1-1/8	20	MC246	SC670	—	—	—
—	225	8-7/8	1-1/8	20	MC246	SC670	—	—	—
—	225	8-7/8	1-1/8	20	MC246	SC653	—	—	—
—	225	8-7/8	1-1/8	20	MC246	SC653	—	—	—
—	225	8-7/8	1-1/8	20	MC246	SC670	—	—	—
—	225	8-7/8	1-1/8	20	MC246	SC653	—	—	—
—	236	9-1/4	1-3/16	21	MC246	SC653	—	—	—
—	225	8-7/8	1-1/8	20	MC246	SC653	—	—	—
—	225	8-7/8	1-1/8	20	MC248	SC654	—	—	TYF505
—	225	8-7/8	1-1/8	20	MC540	SC654	—	—	TYF505
—	225	8-7/8	1-1/8	20	MC558	SC653	—	—	TYF505
—	236	9-1/4	1-3/16	21	MC525	SC861	—	—	TYF509
—	236	9-1/4	1-3/16	21	—	SC861	—	—	TYF509
—	225	8-7/8	1-1/32	23	—	BRG0182	—	—	TYF509
—	236	9-1/4	1-3/16	21	MC246	SC653	—	—	—
—	236	9-1/4	1-3/16	21	MC248	SC654	—	—	—
—	236	9-1/4	1-3/16	21	MC558	SC661	—	—	—
—	236	9-1/4	1-3/16	21	—	SC861	—	—	—
—	236	9-1/4	1-3/16	21	—	SC861	—	—	—
—	236	9-1/4	1-3/16	21	—	SC861	—	—	—

2

Liter	CC/IN	Cyl	Years		Application Information	Kit
			To	From		
TOYOTA continued						
CARINA						
1.6	1588	L4	1972	1973	—	16005
CELICA						
1.6	1587	L4	1990	1990	ST	16064
1.6	1587	L4	1991	1991	ST, From 6/1/91	KTY03
1.6	1587	L4	1991	1991	ST, To 5/31/91	16064
1.6	1587	L4	1992	1993	ST	KTY03
1.8	1762	L4	1994	1995	—	KTY03
1.8	1762	L4	1994	1997	ST	KTY18
1.8	1794	L4	2000	2005	GT, GTS	KTY14
1.9	1898	L4	1971	1971	—	16019
2.0	1968	L4	1972	1974	—	16007
2.0	1995	L4	1986	1986	ST	16072
2.0	1998	L4	1986	1987	GT,GTS,ST	16072
2.0	1998	L4	1988	1988	ALL TRAC Turbo	16082
2.0	1998	L4	1989	1989	ALL TRAC Turbo, To 8/89	16082
2.0	1998	L4	1988	1989	GT,ST	16072
2.0	1998	L4	1989	1989	ALL TRAC Turbo, From 9/89	16082
2.0	1998	L4	1990	1993	ALL TRAC Turbo	KTY11
2.2	2189	L4	1975	1975	From 10/75	16034
2.2	2189	L4	1975	1975	To 9/75	16034
2.2	2189	L4	1976	1976	—	16034
2.2	2189	L4	1977	1977	6/77 - 7/77	16034
2.2	2189	L4	1977	1977	From 8/77	16032
2.2	2189	L4	1977	1977	To 5/77	16034
2.2	2189	L4	1978	1980	—	16032
2.2	2164	L4	1990	1990	GT,GTS From 5/1/90	16073
2.2	2164	L4	1990	1990	GT,GTS To 4/30/90	16072
2.2	2164	L4	1991	1993	GT,GTS	16073
2.2	2164	L4	1994	1999	GT	16073
2.4	2366	L4	1981	1981	GT,ST From 8/81	16084
2.4	2366	L4	1981	1981	GT,ST To 7/81	16084
2.4	2366	L4	1982	1985	GT,GTS,ST	16084
COROLLA						
1.2	1166	L4	1974	1974	From 5/1/74	16004
1.2	1166	L4	1977	1979	—	16004
1.6	1588	L4	1971	1973	—	16005
1.6	1588	L4	1974	1974	—	16005
1.6	1588	L4	1975	1976	—	16005
1.6	1588	L4	1977	1977	—	16005
1.6	1588	L4	1978	1979	—	16066
1.6	1587	L4	1983	1983	RWD, From 8/83	16042
1.6	1587	L4	1983	1983	RWD, To 7/83	16013
1.6	1587	L4	1984	1987	RWD	16042
1.6	1587	L4	1984	1989	FWD	16070
1.6	1587	L4	1985	1987	RWD, GTS	16029
1.6	1587	L4	1987	1988	FWD, FX	16082
1.6	1587	L4	1988	1988	ALL TRAC	16065
1.6	1587	L4	1988	1989	FWD	16074
1.6	1587	L4	1988	1991	RWD, GTS	16074
1.6	1587	L4	1988	1992	RWD	16074
1.6	1587	L4	1989	1989	ALL TRAC from 8/89	16065
1.6	1587	L4	1989	1989	ALL TRAC to 7/89	16065
1.6	1587	L4	1990	1992	ALL TRAC	16065
1.6	1587	L4	1990	1992	FWD	16070
1.6	1587	L4	1992	1997	—	KTY03
1.8	1770	L4	1980	1982	4 Speed	16051
1.8	1770	L4	1980	1982	5 Speed	16042
1.8	1770	L4	1981	1981	5 Spd	16042

EXEDY OEM	Disc (mm)	Disc (in)	Spline Dia	Splines	Master Cylinder	Slave Cylinder	Clutch Cable	Clutch Fork	New Flywheel
—	190	7-1/2	15/16	21	MC250	SC655	—	—	—
—	210	8-1/4	1	21	MC258	SC660	—	—	—
—	210	8-1/4	1	21	MC258	SC660	—	—	—
—	210	8-1/4	1	21	MC258	SC660	—	—	—
—	210	8-1/4	1	21	MC258	SC660	—	—	—
—	210	8-1/4	1	21	MC258	SC660	—	—	TYF503
—	210	8-1/4	1	21	MC566	SC818	—	—	TYF503
Y	210	8-1/4	1	21	MC524	SC856	—	—	TYF513
—	200	7-7/8	1-3/16	21	MC471	SC819	—	—	—
—	225	8-7/8	1-3/16	21	MC250	SC656	—	—	—
—	225	8-7/8	1-1/8	20	MC263	SC653	—	—	—
—	225	8-7/8	1-1/8	20	MC263	SC670	—	—	—
—	236	9-1/4	1-3/16	21	MC263	SC653	—	—	—
—	236	9-1/4	1-3/16	21	MC263	SC653	—	—	—
—	225	8-7/8	1-1/8	20	MC263	SC653	—	—	—
—	236	9-1/4	1-3/16	21	MC258	SC661	—	—	—
—	236	9-1/4	1-3/16	21	MC258	SC661	—	—	—
—	225	8-7/8	1-3/16	21	MC252	SC658	—	—	—
—	225	8-7/8	1-3/16	21	MC250	SC658	—	—	—
—	225	8-7/8	1-3/16	21	MC252	SC658	—	—	—
—	225	8-7/8	1-3/16	21	MC250	SC658	—	—	—
—	225	8-7/8	1-3/16	21	MC254	SC658	—	—	—
—	225	8-7/8	1-3/16	21	MC252	SC658	—	—	—
—	225	8-7/8	1-3/16	21	MC254	SC659	—	—	—
—	225	8-7/8	1-1/8	20	MC258	SC653	—	—	TYF505
—	225	8-7/8	1-1/8	20	MC258	SC653	—	—	TYF505
—	225	8-7/8	1-1/8	20	MC258	SC653	—	—	TYF505
—	225	8-7/8	1-1/8	20	MC566	SC653	—	—	TYF505
—	225	8-7/8	1-3/16	21	MC254	SC659	—	—	—
—	225	8-7/8	1-3/16	21	MC254	SC659	—	—	—
—	225	8-7/8	1-3/16	21	MC256	SC659	—	—	—
—	184	7-1/4	7/8	19	—	SC655	—	—	—
—	184	7-1/4	7/8	19	—	—	—	—	—
—	190	7-1/2	15/16	21	MC261	SC655	—	—	—
—	190	7-1/2	15/16	21	MC261	SC667	—	—	—
—	190	7-1/2	15/16	21	MC250	SC658	—	—	—
—	190	7-1/2	15/16	21	MC471	SC658	—	—	—
—	190	7-1/2	15/16	21	MC471	SC659	—	—	—
—	200	7-7/8	15/16	21	MC263	SC668	—	—	TYF508
—	210	8-1/4	1	21	MC263	SC668	—	—	TYF508
—	200	7-7/8	15/16	21	MC263	SC668	—	—	TYF508
—	200	7-7/8	15/16	21	MC256	SC669	—	—	TYF508
—	200	7-7/8	15/16	21	MC256	SC669	—	—	—
—	236	9-1/4	1-3/16	21	MC256	SC669	—	—	TYF508
—	225	8-7/8	1-3/16	21	MC253	SC660	—	—	—
—	210	8-1/4	1	21	MC251	SC818	—	—	—
—	210	8-1/4	1	21	MC265	SC660	—	—	—
—	210	8-1/4	1	21	MC265	SC660	—	—	—
—	225	8-7/8	1-3/16	21	MC266	SC660	—	—	—
—	225	8-7/8	1-3/16	21	MC253	SC660	—	—	—
—	225	8-7/8	1-3/16	21	MC266	SC660	—	—	—
—	200	7-7/8	15/16	21	MC265	SC660	—	—	TYF508
—	210	8-1/4	1	21	MC265	SC660	—	—	TYF503
—	210	8-1/4	1	21	MC473	SC659	—	—	—
—	200	7-7/8	15/16	21	MC473	SC659	—	—	—
—	200	7-7/8	15/16	21	MC262	SC668	—	—	—

Liter	CC/IN	Cyl	Years		Application Information	Kit
			To	From		
TOYOTA continued						
<i>COROLLA continued</i>						
1.8	1770	L4	1981	1982	4 Spd,8-1/4"	16051
1.8	1770	L4	1981	1982	5 Spd,7-7/8"	16042
1.8	1839	L4	1984	1985	Diesel	16054
1.8	1762	L4	1993	1993	4WD	KTY14
1.8	1762	L4	1993	1997	FWD	KTY03
1.8	1794	L4	1998	2001	FWD	KTY03
1.8	1794	L4	2002	2002	FWD	KTY03
1.8	1794	L4	2003	2008	FWD, Sold As Kit Only	TYK1501
1.8	1795	L4	2005	2008	6 Speed, XRS	KTY14
1.8	1795	L4	2009	2013	Sold as Kit Only	TYK1518
1.8	1795	L4	2014	2018	Sold as Kit Only, Include CSC Hydraulic Slave Cylinder	TYK1522
2.4	2362	L4	2010	2011	6 Speed, XRS	TYK1506
CORONA						
1.9	1898	L4	1967	1970	—	16003
1.9	1898	L4	1967	1970	—	16030
1.9	1858	L4	1969	1969	Mark II from 2/69	16003
1.9	1858	L4	1969	1971	Mark II	16003
1.9	1858	L4	1970	1970	Mark II to 1/70	16003
1.9	1898	L4	1970	1970	—	16019
1.9	1858	L4	1971	1971	—	16003
1.9	1858	L4	1971	1971	—	16019
1.9	1858	L4	1971	1971	Mark II	16030
2.0	1968	L4	1972	1972	—	16007
2.0	1968	L4	1972	1972	Mark II	16034
2.0	1968	L4	1973	1973	From 8/73	16007
2.0	1968	L4	1973	1973	To 7/73	16007
2.0	1968	L4	1974	1974	—	16007
2.2	2189	L4	1975	1977	—	16007
2.2	2189	L4	1978	1980	—	16016
2.4	2366	L4	1981	1982	—	16084
CRESSIDA						
2.8	2754	L6	1983	1987	—	16018
CROWN						
2.3	2253	L6	1967	1969	To 1/70	16033
2.3	2253	L6	1970	1970	From 2/70	16034
ECHO						
1.5	1497	L4	2000	2005	—	KTY15
GT86						
2.0	1994	H4	2013	2018	Sold as Kit Only	FJK1005
MARK II						
2.3	2253	L6	1972	1972	—	16034
2.6	2563	L6	1973	1974	—	16034
MATRIX						
1.8	1794	L4	2003	2008	5 Speed, XR	TYK1501
1.8	1795	L4	2003	2006	6 Speed, XRS	KTY14
1.8	1795	L4	2009	2013	Sold as Kit Only	TYK1518
2.4	2362	L4	2009	2011	6 Speed, XRS	TYK1506
MR2, MR2 SPYDER						
1.6	1587	L4	1985	1985	—	16029
1.6	1587	L4	1986	1989	—	16064
1.6	1587	L4	1988	1989	Supercharged	16075
1.8	1794	L4	2000	2004	Excludes Sequential Shift Trans	KTY03
2.0	1998	L4	1991	1991	Turbo	16062
2.0	1998	L4	1992	1995	Turbo	16062
2.2	2164	L4	1991	1991	—	16073
2.2	2164	L4	1992	1995	—	16073

2

EXEDY OEM	Disc (mm)	Disc (in)	Spline Dia	Splines	Master Cylinder	Slave Cylinder	Clutch Cable	Clutch Fork	New Flywheel
—	210	8-1/4	1	21	MC262	SC668	—	—	—
—	200	7-7/8	15/16	21	MC262	SC668	—	—	—
—	211	8-5/16	1-3/16	20	MC264	SC670	—	—	—
Y	210	8-1/4	1	21	MC265	SC818	—	—	—
—	210	8-1/4	1	21	MC265	SC818	—	—	TYF503
—	210	8-1/4	1	21	MC265	SC842	—	—	—
—	210	8-1/4	1	21	MC265	SC842	—	—	—
—	213	8-3/8	15/16	21	MC524	SC874	—	—	—
Y	210	8-1/4	1	21	MC525	SC874	—	—	TYF513
—	212	8-1/4	15/16	21	MC573	—	—	—	TYF512
—	210	8-1/4	1	21	—	BRG0222	—	—	—
—	236	9-1/4	1-3/16	21	MC573	SC907	—	—	TYF509
—	200	7-7/8	15/16	21	MC271	SC656	—	—	—
—	200	7-7/8	15/16	21	MC269	SC656	—	—	—
—	200	7-7/8	15/16	21	MC271	SC656	—	—	—
—	200	7-7/8	15/16	21	MC269	SC819	—	—	—
—	200	7-7/8	15/16	21	MC271	SC656	—	—	—
—	200	7-7/8	1-3/16	21	MC269	SC819	—	—	—
—	200	7-7/8	15/16	21	MC271	SC656	—	—	—
—	200	7-7/8	1-3/16	21	MC289	SC656	—	—	—
—	200	7-7/8	15/16	21	MC269	SC656	—	—	—
—	225	8-7/8	1-3/16	21	MC270	SC656	—	—	—
—	225	8-7/8	1-3/16	21	MC475	SC676	—	—	—
—	225	8-7/8	1-3/16	21	MC254	SC656	—	—	—
—	225	8-7/8	1-3/16	21	MC270	SC656	—	—	—
—	225	8-7/8	1-3/16	21	MC254	SC656	—	—	—
—	225	8-7/8	1-3/16	21	MC252	SC657	—	—	—
—	225	8-7/8	1-3/16	21	MC254	SC677	—	—	—
—	225	8-7/8	1-3/16	21	MC254	SC659	—	—	—
—	236	9-1/4	1-3/16	21	MC274	SC666	—	—	—
—	225	8-7/8	15/16	21	—	SC676	—	—	—
—	225	8-7/8	1-3/16	21	—	SC676	—	—	—
—	210	8-1/4	1	21	MC535	SC841	—	—	—
Y	230	9-1/16	1	24	—	—	—	—	TYF001
—	225	8-7/8	1-3/16	21	—	SC676	—	—	—
—	225	8-7/8	1-3/16	21	—	SC676	—	—	—
—	213	8-3/8	15/16	21	MC524	SC874	—	—	—
Y	210	8-1/4	1	21	MC525	SC874	—	—	TYF513
—	212	8-1/4	15/16	21	MC573	—	—	—	TYF512
—	236	9-1/4	1-3/16	21	MC573	SC907	—	—	TYF509
—	200	7-7/8	15/16	21	MC289	SC688	—	—	—
—	210	8-1/4	1	21	MC289	SC688	—	—	—
—	225	8-7/8	1-3/16	21	MC289	SC685	—	—	—
—	210	8-1/4	1	21	—	SC857	—	—	—
—	236	9-1/4	1-3/16	21	MC290	SC690	—	—	—
—	236	9-1/4	1-3/16	21	MC290	SC691	—	—	—
—	225	8-7/8	1-1/8	20	—	—	—	—	—
—	225	8-7/8	1-1/8	20	—	SC691	—	—	—

Liter	CC/IN	Cyl	Years		Application Information	Kit
			To	From		

TOYOTA continued

PASEO

1.5	1497	L4	1992	1995	To 8/95	16029
1.5	1497	L4	1995	1999	From 9/75	16029

SOLARA

2.2	2164	L4	1999	2001	—	16073
2.4	2362	L4	2002	2003	—	TYK1506
2.4	2362	L4	2004	2008	—	TYK1506
3.0	2995	V6	1999	2001	—	16062
3.0	2995	V6	2002	2002	—	16062

STARLET

1.3	1290	L4	1981	1982	—	16004
1.3	1290	L4	1983	1983	—	16037

SUPRA

2.6	2563	L6	1979	1980	—	16016
2.8	2759	L6	1981	1981	To 7/81	16084
2.8	2754	L6	1982	1982	—	16018
2.8	2754	L6	1983	1983	—	16018
2.8	2754	L6	1984	1985	—	16018
3.0	2954	L6	1986	1988	Non-Turbo	16018
3.0	2954	L6	1987	1992	Turbo	16063
3.0	2954	L6	1989	1993	Non-Turbo	16069
3.0	2997	L6	1990	1993	Turbo	16063
3.0	2997	L6	1994	1997	Non-Turbo	16085
3.0	2997	L6	1994	1998	Turbo	16093

TERCEL

1.5	1452	L4	1980	1982	—	16009
1.5	1452	L4	1983	1985	—	16039
1.5	1452	L4	1986	1988	—	16039
1.5	1456	L4	1987	1987	4 Spd	16064
1.5	1456	L4	1987	1988	5 Spd	16060
1.5	1456	L4	1988	1988	EZ Model	16064
1.5	1456	L4	1989	1989	Except EZ Model to 4/89	16060
1.5	1456	L4	1989	1990	Except EZ Model from 5/89	16060
1.5	1456	L4	1990	1990	EZ Model	16064
1.5	1456	L4	1990	1994	5 Spd	16060
1.5	1456	L4	1991	1994	4 Spd	16070
1.5	1497	L4	1995	1998	—	16070

YARIS

1.5	1497	L4	2006	2006	Sold as kit only	TYK1504
1.5	1497	L4	2007	2011	Sold as kit only	TYK1504

TOYOTA LIGHT TRUCK, SUV & VAN

4RUNNER

2.4	2366	L4	1984	1984	—	16084
2.4	2366	L4	1985	1986	Turbo	16018
2.4	2366	L4	1985	1988	Non-Turbo	16057
2.4	2366	L4	1987	1987	Turbo from 6/87	16069
2.4	2366	L4	1987	1987	Turbo to 5/87	16018
2.4	2366	L4	1989	1995	2 WD	16058
2.4	2366	L4	1993	1995	4 WD	16069
2.7	2694	L4	1996	2000	—	16090
3.0	2959	V6	1988	1995	—	16059
3.4	3378	V6	1996	2001	—	16087

FJ CRUISER

4.0	3956	V6	2007	2014	Sold as Kit Only	TYK1503
-----	------	----	------	------	------------------	---------

EXEDY OEM	Disc (mm)	Disc (in)	Spline Dia	Splines	Master Cylinder	Slave Cylinder	Clutch Cable	Clutch Fork	New Flywheel
—	200	7-7/8	15/16	21	MC285	SC684	—	—	TYF506
—	200	7-7/8	15/16	21	MC285	SC685	—	—	TYF506
—	225	8-7/8	1-1/8	20	MC558	SC653	—	—	TYF505
—	236	9-1/4	1-3/16	21	MC558	SC861	—	—	TYF509
—	236	9-1/4	1-3/16	21	MC524	SC861	—	—	TYF509
—	236	9-1/4	1-3/16	21	MC558	SC661	—	—	—
—	236	9-1/4	1-3/16	21	—	SC661	—	—	—
—	184	7-1/4	7/8	19	—	—	—	—	—
—	190	7-1/2	3/4	19	—	—	—	—	—
—	225	8-7/8	1-3/16	21	MC254	SC665	—	—	—
—	225	8-7/8	1-3/16	21	MC254	SC665	—	—	—
—	236	9-1/4	1-3/16	21	MC255	SC666	—	—	—
—	236	9-1/4	1-3/16	21	MC256	SC666	—	—	—
—	236	9-1/4	1-3/16	21	MC255	SC666	—	—	—
—	236	9-1/4	1-3/16	21	MC257	SC672	—	—	—
—	240	9-1/2	1-3/16	21	MC257	SC673	—	—	—
—	236	9-1/4	1-3/16	21	MC257	SC666	—	—	—
—	240	9-1/2	1-3/16	21	MC257	SC673	—	—	—
—	236	9-1/4	1-3/16	21	MC268	SC674	—	—	—
—	250	9-7/8	1-1/4	14	MC268	—	—	—	—
—	190	7-1/2	1	21	—	—	—	—	—
—	190	7-1/2	1	21	—	—	—	—	—
—	190	7-1/2	1	21	MC283	SC684	—	—	—
—	210	8-1/4	1	21	MC283	SC684	—	—	TYF506
—	190	7-1/2	15/16	21	MC283	SC684	—	—	TYF506
—	210	8-1/4	1	21	MC283	SC684	—	—	—
—	190	7-1/2	15/16	21	MC283	SC684	—	—	TYF506
—	190	7-1/2	15/16	21	MC284	SC684	—	—	TYF506
—	210	8-1/4	1	21	MC284	SC684	—	—	—
—	190	7-1/2	15/16	21	MC285	SC684	—	—	TYF506
—	200	7-7/8	15/16	21	MC285	SC684	—	—	TYF506
—	200	7-7/8	15/16	21	MC285	SC685	—	—	—
—	210	8-1/4	1	21	—	—	—	—	—
—	210	8-1/4	1	21	MC572	SC905	—	—	—
—	225	8-7/8	1-3/16	21	MC274	SC677	—	—	TYF520
—	236	9-1/4	1-3/16	21	MC274	SC680	—	—	TYF507
—	225	8-7/8	1-3/16	21	MC274	SC677	—	—	TYF520
—	236	9-1/4	1-3/16	21	MC274	SC680	—	—	TYF507
—	236	9-1/4	1-3/16	21	MC274	SC680	—	—	TYF507
—	225	8-7/8	1-3/16	21	MC272	SC677	—	—	TYF520
—	236	9-1/4	1-3/16	21	MC272	SC677	—	—	TYF507
—	250	9-7/8	1-3/16	21	MC276	SC683	—	—	TYF511
—	236	9-1/4	1-3/16	21	MC272	SC677	—	—	TYF501
—	250	9-7/8	1-3/16	21	MC276	SC682	—	—	TYF502
—	275	10-7/8	1-3/16	21	—	—	—	—	TYF510

Liter	CC/IN	Cyl	Years		Application Information	Kit
			To	From		
TOYOTA LIGHT TRUCK, SUV & VAN continued						
<i>LAND CRUISER</i>						
3.4	3431	L4	1981	1985	Diesel	16040
3.9	3878	L6	1967	1970	To 6/70	16040
3.9	3878	L6	1971	1973	—	16040
3.9	3878	L6	1974	1974	—	16040
4.2	4227	L6	1975	1979	—	16006
4.2	4227	L6	1980	1980	—	16006
4.2	4227	L6	1981	1985	To 5/85	16006
4.2	4227	L6	1985	1987	From 6/85	16006
<i>PICKUP</i>						
1.9	1858	L4	1970	1971	—	16045
2.0	1968	L4	1972	1972	To 4/72	16007
2.0	1968	L4	1972	1972	From 5/72	16007
2.0	1968	L4	1973	1973	To 4/73	16007
2.0	1968	L4	1973	1973	From 5/73	16007
2.0	1968	L4	1974	1974	To 7/74	16007
2.0	1968	L4	1974	1974	From 8/74	16007
2.2	2189	L4	1975	1975	—	16007
2.2	2189	L4	1976	1976	From 9/76	16007
2.2	2189	L4	1976	1976	To 8/76	16007
2.2	2189	L4	1977	1977	—	16007
2.2	2189	L4	1978	1978	From 8/1/78	16032
2.2	2189	L4	1978	1978	To 7/1/78	16007
2.2	2189	L4	1979	1980	—	16032
2.2	2188	L4	1981	1981	Diesel, to 3/81	16057
2.2	2188	L4	1982	1982	Diesel, from 9/82	16057
2.2	2188	L4	1983	1983	Diesel	16057
2.2	2188	L4	1983	1983	Diesel	16057
2.4	2366	L4	1981	1986	—	16057
2.4	2446	L4	1984	1984	Diesel	16057
2.4	2446	L4	1984	1985	Diesel	16057
2.4	2366	L4	1985	1985	Turbo, to 5/87	16018
2.4	2446	L4	1985	1985	Turbo Diesel	16057
2.4	2366	L4	1986	1986	Diesel	16057
2.4	2366	L4	1986	1986	Diesel	16057
2.4	2366	L4	1986	1987	Turbo, to 5/87	16018
2.4	2366	L4	1987	1987	Diesel	16057
2.4	2366	L4	1987	1987	Turbo, from 6/87	16069
2.4	2366	L4	1987	1988	Non-Turbo	16057
2.4	2366	L4	1988	1988	Turbo, from 6/87	16069
2.4	2366	L4	1989	1992	—	16058
2.4	2366	L4	1993	1995	2 WD	16058
2.4	2366	L4	1993	1995	4 WD	16069
3.0	2959	V6	1988	1995	—	16059
<i>PREVIA VAN</i>						
2.4	2438	L4	1991	1993	—	KTY13
<i>RAV4</i>						
2.0	1998	L4	1996	2000	—	TYK1502
2.0	1998	L4	2001	2003	—	TYK1502
2.4	2362	L4	2004	2005	—	16082
<i>T100</i>						
2.7	2694	L4	1994	1998	—	16090
3.0	2959	V6	1993	1994	2WD	16059
3.0	2959	V6	1993	1994	4 WD	KTY16
3.4	3378	V6	1995	1998	—	16087

2

EXEDY OEM	Disc (mm)	Disc (in)	Spline Dia	Splines	Master Cylinder	Slave Cylinder	Clutch Cable	Clutch Fork	New Flywheel
—	273	10-3/4	1-3/32	10	—	SC814	—	—	—
—	273	10-3/4	1-3/32	10	MC294	SC698	—	—	—
—	273	10-3/4	1-3/32	10	MC490	SC813	—	—	—
—	273	10-3/4	1-3/32	10	MC490	SC815	—	—	—
—	273	10-3/4	1-3/32	10	MC468	SC815	—	—	—
—	273	10-3/4	1-3/32	10	MC297	SC697	—	—	—
—	273	10-3/4	1-3/32	10	MC297	SC697	—	—	—
—	273	10-3/4	1-3/32	10	MC298	SC699	—	—	—
—	225	8-7/8	15/16	21	MC278	SC819	—	—	—
—	225	8-7/8	1-3/16	21	MC278	SC656	—	—	TYF520
—	225	8-7/8	1-3/16	21	MC279	SC556	—	—	TYF520
—	225	8-7/8	1-3/16	21	MC279	SC656	—	—	TYF520
—	225	8-7/8	1-3/16	21	MC279	SC657	—	—	TYF520
—	225	8-7/8	1-3/16	21	MC279	SC657	—	—	TYF520
—	225	8-7/8	1-3/16	21	MC280	SC657	—	—	TYF520
—	225	8-7/8	1-3/16	21	MC280	SC657	—	—	TYF520
—	225	8-7/8	1-3/16	21	MC281	SC657	—	—	TYF520
—	225	8-7/8	1-3/16	21	MC280	SC657	—	—	TYF520
—	225	8-7/8	1-3/16	21	MC281	SC657	—	—	—
—	225	8-7/8	1-3/16	21	MC274	SC677	—	—	—
—	225	8-7/8	1-3/16	21	MC281	SC657	—	—	—
—	225	8-7/8	1-3/16	21	MC274	SC677	—	—	—
—	225	8-7/8	1-3/16	21	MC274	SC817	—	—	—
—	225	8-7/8	1-3/16	21	MC274	SC677	—	—	—
—	225	8-7/8	1-3/16	21	MC274	SC677	—	—	—
—	225	8-7/8	1-3/16	21	MC481	SC666	—	—	TYF520
—	225	8-7/8	1-3/16	21	MC274	SC677	—	—	—
—	225	8-7/8	1-3/16	21	—	SC686	—	—	—
—	225	8-7/8	1-3/16	21	MC274	SC686	—	—	TYF507
—	236	9-1/4	1-3/16	21	—	—	—	—	—
—	225	8-7/8	1-3/16	21	MC274	SC677	—	—	—
—	225	8-7/8	1-3/16	21	—	SC666	—	—	—
—	225	8-7/8	1-3/16	21	MC274	SC666	—	—	TYF507
—	236	9-1/4	1-3/16	21	MC274	SC677	—	—	—
—	225	8-7/8	1-3/16	21	MC481	SC666	—	—	TYF507
—	236	9-1/4	1-3/16	21	MC274	SC677	—	—	—
—	225	8-7/8	1-3/16	21	MC274	SC677	—	—	—
—	236	9-1/4	1-3/16	21	—	—	—	—	TYF507
—	225	8-7/8	1-3/16	21	MC272	SC677	—	—	TYF520
—	225	8-7/8	1-3/16	21	MC272	SC677	—	—	TYF520
—	236	9-1/4	1-3/16	21	MC272	SC677	—	—	TYF507
—	236	9-1/4	1-3/16	21	MC272	SC677	—	—	TYF501
—	236	9-1/4	1-3/16	21	MC287	SC687	—	—	TYF504
—	236	9-1/4	1-3/16	21	MC523	SC661	—	—	—
—	236	9-1/4	1-3/16	21	MC521	SC661	—	—	—
—	236	9-1/4	1-3/16	21	MC521	SC861	—	—	TYF509
—	250	9-7/8	1-3/16	21	MC275	SC681	—	—	TYF511
—	236	9-1/4	1-3/16	21	MC275	SC677	—	—	TYF501
—	250	9-7/8	1-3/16	21	MC275	SC677	—	—	—
—	250	9-7/8	1-3/16	21	MC275	SC682	—	—	—

2

Liter	CC/IN	Cyl	Years		Application Information	Kit
			To	From		
TOYOTA LIGHT TRUCK, SUV & VAN continued						
TACOMA						
2.4	2438	L4	1995	2000	—	KTY13
2.4	2438	L4	2001	2004	2 WD	KTY13
2.4	2438	L4	2001	2004	4 WD	16090
2.7	2694	L4	1995	2004	—	16090
2.7	2694	L4	2005	2011	Fits 2WD and 4WD	KTY16
3.4	3378	V6	1995	2004	—	16087
4.0	3956	V6	2005	2015	Sold as Kit Only	TYK1515
TUNDRA						
3.4	3378	V6	2000	2004	—	16087
4.0	3956	V6	2005	2006	Sold as Kit Only	TYK1503
VAN						
2.0	1998	L4	1984	1985	—	16046
2.2	2237	L4	1986	1988	—	16046
2.2	2237	L4	1989	1989	—	KTY02
VOLKSWAGEN						
BEETLE (NEW)						
1.8	1781	L4	1999	2004	Turbo, Includes DMF. Cover has 3 bolt sections with 4 bolts per section, Sold As Kit Only	VWK1000
1.9	1896	L4	1998	1998	Turbo Diesel, LUK Version, Sold As Kit Only	VWK1000
1.9	1896	L4	1998	1998	Turbo Diesel, Sachs Version, Sold As Kit Only	KVW03
1.9	1896	L4	1999	2000	Turbo Diesel, LUK Version, Sold As Kit Only	VWK1000
1.9	1896	L4	1999	2000	Turbo Diesel, Sachs Version, Sold As Kit Only	KVW03
1.9	1896	L4	2001	2003	Turbo Diesel, LUK Version, Sold As Kit Only	VWK1000
1.9	1896	L4	2001	2005	Turbo Diesel, Sachs Version, Sold As Kit Only	KVW03
2.0	1984	L4	1998	2005	Sold As Kit Only	KVW05
2.5	2480	L5	2006	2008	Sold as Kit Only	VWK1004
BEETLE, GHIA (TYPE I)						
1.2	1192	H4	1954	1966	—	17015
1.3	1285	H4	1966	1966	—	17015
CABRIO						
2.0	1984	L4	1995	1997	—	17038
2.0	1984	L4	1998	2002	—	17038
CABRIOLET						
1.8	1780	L4	1985	1989	—	17012
1.8	1780	L4	1990	1993	—	17012
CORRADO						
1.8	1780	L4	1990	1992	—	17034
2.8	2792	V6	1992	1992	VR6	17036
2.8	2792	V6	1993	1993	VR6, From 9/93	17036
2.8	2792	V6	1993	1993	VR6, To 8/93	17036
2.8	2792	V6	1994	1995	VR6	17036
DASHER						
1.5	1471	L4	1974	1975	Gas	17002
1.5	1471	L4	1979	1980	Diesel	17002
1.6	1588	L4	1981	1981	Diesel	17002
EOS						
2.0	1984	L4	2007	2007	Turbo, Includes Slave Cylinder, Sold as Kit Only	VWK1005
FASTBACK, SQUAREBACK (TYPE III)						
1.6	1584	H4	1966	1969	Rigid Disc Option	17022
1.6	1584	H4	1970	1970	Rigid Disc Option, From 8/1/70	17023
1.6	1584	H4	1970	1970	To 7/31/70, Rigid Disc Option	17022
1.6	1584	H4	1970	1973	Rigid Disc Option, From 8/1/70	17022
FOX						
1.8	1780	L4	1987	1990	—	17032
1.8	1780	L4	1991	1993	—	17032

EXEDY OEM	Disc (mm)	Disc (in)	Spline Dia	Splines	Master Cylinder	Slave Cylinder	Clutch Cable	Clutch Fork	New Flywheel
—	236	9-1/4	1-3/16	21	MC275	SC683	—	—	—
—	236	9-1/4	1-3/16	21	MC275	SC683	—	—	TYF504
—	250	9-7/8	1-3/16	21	MC275	SC683	—	—	TYF504
—	250	9-7/8	1-3/16	21	MC275	SC683	—	—	TYF511
—	250	9-7/8	1-3/16	21	—	SC879	—	—	TYF518
—	250	9-7/8	1-3/16	21	MC275	SC682	—	—	TYF502
—	275	10-7/8	1-3/16	21	—	SC878	—	—	TYF510
—	250	9-7/8	1-3/16	21	MC275	SC682	—	—	TYF502
—	275	10-7/8	1-3/16	21	MC530	SC878	—	—	TYF510
—	225	8-7/8	1-3/16	21	MC469	SC687	—	—	—
—	225	8-7/8	1-3/16	21	MC469	SC687	—	—	—
—	225	8-7/8	1-3/16	21	MC469	SC677	—	—	TYF520
—	225	8-7/8	7/8	28	MC110	—	—	—	—
—	225	8-7/8	7/8	28	MC110	—	—	—	—
—	228	9	7/8	28	MC110	—	—	—	—
—	225	8-7/8	7/8	28	MC110	SC512	—	—	—
—	228	9	7/8	28	MC110	SC512	—	—	—
—	225	8-7/8	7/8	28	MC110	—	—	—	—
—	228	9	7/8	28	MC110	—	—	—	—
—	215	8-7/16	7/8	28	MC110	—	—	—	—
—	228	9	7/8	28	MC110	—	—	—	—
—	184	7-1/4	13/16	24	—	—	—	—	—
—	184	7-1/4	13/16	24	—	—	—	—	—
—	210	8-1/4	7/8	28	MC107	SC511	—	—	—
—	210	8-1/4	7/8	28	—	—	—	—	—
—	210	8-1/4	13/16	24	—	—	CC953	—	—
—	210	8-1/4	13/16	24	—	—	—	—	—
—	228	9	7/8	28	MC103	SC900	—	—	—
—	228	9	7/8	28	MC103	SC900	—	—	—
—	228	9	7/8	28	MC106	SC900	—	—	—
—	228	9	7/8	28	MC103	SC900	—	—	—
—	228	9	7/8	28	MC106	SC900	—	—	—
—	190	7-1/2	1	24	—	—	—	—	—
—	190	7-1/2	1	24	—	—	—	—	—
—	190	7-1/2	1	24	—	—	—	—	—
—	240	9-7/16	15/16	23	—	—	—	—	—
—	200	7-7/8	13/16	24	—	—	—	—	—
—	200	7-7/8	13/16	24	—	—	—	—	—
—	200	7-7/8	13/16	24	—	—	—	—	—
—	200	7-7/8	13/16	24	—	—	—	—	—
—	210	8-1/4	13/16	24	—	—	CC971	—	—
—	210	8-1/4	13/16	24	—	—	—	—	—

Liter	CC/IN	Cyl	Years		Application Information	Kit
			To	From		
VOLKSWAGEN continued						
<i>GOLF</i>						
1.6	1588	L4	1985	1988	Diesel to CH # 1GL015951	17004
1.8	1780	L4	1985	1992	—	17012
1.8	1780	L4	1987	1989	GTI 16 Valve	17027
1.8	1780	L4	1990	1992	GTI 8 Valve	17012
1.8	1781	L4	2000	2000	Turbo, Includes DMF. Cover has 3 bolt sections with 4 bolts per section, Sold As Kit Only	VWK1000
1.8	1781	L4	2001	2005	Turbo, Includes DMF. Cover has 3 bolt sections with 4 bolts per section, Sold As Kit Only	VWK1000
1.8	1781	L4	2006	2006	Turbo, Includes DMF. Cover has 3 bolt sections with 4 bolts per section, Sold As Kit Only	VWK1000
1.9	1896	L4	2000	2003	Turbo Diesel, LUK Version, Sold As Kit Only	VWK1000
1.9	1896	L4	2000	2003	Turbo Diesel, Sachs Version, Sold As Kit Only	KVW03
1.9	1896	L4	2004	2004	Turbo Diesel, LUK Version, Sold As Kit Only	VWK1000
1.9	1896	L4	2004	2004	Turbo Diesel, Sachs Version, Sold As Kit Only	KVW03
2.0	1984	L4	1990	1992	GTI 16 Valve	17027
2.0	1984	L4	1993	1994	—	17027
2.0	1984	L4	1995	1998	—	17038
2.0	1984	L4	1999	2005	Sold As Kit Only	KVW05
2.0	1984	L4	2004	2005	Turbo, Includes DMF. Cover has 3 bolt sections with 4 bolts per section, Sold As Kit Only	VWK1000
2.0	1984	L4	2006	2008	Turbo, Includes Slave Cylinder, Sold as Kit Only	VWK1005
2.8	2792	V6	1995	1998	GTI VR6	17036
2.8	2792	V6	1999	2002	GTI VR6	17036
3.2	3189	V6	2004	2004	Sold as Kit Only	VWK1006
<i>GOLF (CANADA)</i>						
1.6	1588	L4	1989	1989	Diesel to CH # 1GL015951	17004
1.6	1588	L4	1990	1992	Diesel from Ch # 1GL015951	17035
1.8	1788	L4	1993	1993	To Chassis # 1H-R038 600	17012
1.8	1788	L4	1995	1995	From Chassis # 1H-R-038 601, Sold As Kit Only	KVW01
1.8	1780	L4	1996	1997	From Chassis # 1H-R-038 601, Sold As Kit Only	KVW01
1.9	1896	L4	1996	1997	Turbo Diesel	17034
<i>JETTA</i>						
1.6	1588	L4	1980	1980	—	17004
1.6	1588	L4	1981	1989	Diesel to Chassis # 1G-L-015 951	17004
1.6	1588	L4	1983	1988	Turbo Diesel to Chassis # 1G-L-015 951	17004
1.6	1588	L4	1990	1992	Diesel from Chassis # 1G-L-015 952	17035
1.7	1715	L4	1981	1984	—	17004
1.8	1780	L4	1984	1984	—	17012
1.8	1780	L4	1985	1992	—	17012
1.8	1780	L4	1987	1989	GLI 16 Valve	17027
1.8	1788	L4	1993	1994	—	17012
1.8	1788	L4	1995	1995	From Chassis # 1H-R-0380601, Sold As Kit Only	KVW01
1.8	1781	L4	2000	2000	Turbo, Includes DMF. Cover has 3 bolt sections with 4 bolts per section, Sold As Kit Only	VWK1000
1.8	1781	L4	2001	2004	Turbo, Includes DMF. Cover has 3 bolt sections with 4 bolts per section, Sold As Kit Only	VWK1000
1.9	1896	L4	1996	1997	Turbo Diesel	17034
1.9	1896	L4	1998	1998	Turbo Diesel, Sachs Version, Sold As Kit Only	KVW03
1.9	1896	L4	1999	1999	Turbo Diesel, LUK Version, Sold As Kit Only	VWK1000
1.9	1896	L4	1999	1999	Turbo Diesel, Sachs Version, Sold As Kit Only, Fits DMF	KVW03
1.9	1896	L4	2000	2003	Turbo Diesel, LUK Version, Sold As Kit Only	VWK1000
1.9	1896	L4	2004	2004	Turbo Diesel, Sachs Version, Sold As Kit Only, Fits DMF	KVW03
1.9	1896	L4	2005	2006	BRM Engine	VWK1004
2.0	1984	L4	1990	1993	16 Valve	17027
2.0	1984	L4	1994	1994	From CH #1H-R-038601	17027
2.0	1984	L4	1994	1994	To CH #1H-R-038600	17038
2.0	1984	L4	1995	1998	—	17038
2.0	1984	L4	1999	1999	—	17038
2.0	1984	L4	2000	2005	Sold As Kit Only	KVW05
2.0	1984	L4	2006	2007	Turbo, Includes Slave Cylinder, Sold as Kit Only	VWK1005
2.5	2480	L5	2005	2008	Sold as Kit Only	VWK1004
2.8	2792	V6	1994	1998	AFP Engine	17036
2.8	2792	V6	1999	1999	—	17036
2.8	2792	V6	1999	2002	AFP Engine	17036
2.8	2792	V6	2002	2002	Includes Slave Cylinder, Sold as kit only	VWK1002
2.8	2792	V6	2002	2004	Includes Slave Cylinder, Sold as kit only, BDF Engine	VWK1002

2

EXEDY OEM	Disc (mm)	Disc (in)	Spline Dia	Splines	Master Cylinder	Slave Cylinder	Clutch Cable	Clutch Fork	New Flywheel
—	200	7-7/8	13/16	24	—	—	—	—	—
—	210	8-1/4	13/16	24	—	—	—	—	—
—	210	8-1/4	7/8	28	—	—	CC968	—	—
—	210	8-1/4	13/16	24	—	—	—	—	—
—	225	8-7/8	7/8	28	—	—	—	—	—
—	225	8-7/8	7/8	28	MC110	—	—	—	—
—	225	8-7/8	7/8	28	—	—	—	—	—
—	225	8-7/8	7/8	28	—	—	—	—	—
—	228	9	7/8	28	—	—	—	—	—
—	225	8-7/8	7/8	28	MC110	—	—	—	—
—	228	9	7/8	28	MC110	—	—	—	—
—	210	8-1/4	7/8	28	—	—	—	—	—
—	210	8-1/4	7/8	28	—	—	—	—	—
—	210	8-1/4	7/8	28	—	—	—	—	—
—	215	8-7/16	7/8	28	MC110	—	—	—	—
—	225	8-7/8	7/8	28	MC110	—	—	—	—
—	240	9-7/16	15/16	23	—	—	—	—	—
—	228	9	7/8	28	MC107	SC900	—	—	—
—	228	9	7/8	28	MC109	SC512	—	—	—
—	240	9 7/16	15/16	23	MC110	—	—	—	—
—	200	7-7/8	13/16	24	—	—	—	—	—
—	200	7-7/8	13/16	24	—	—	—	—	—
—	210	8-1/4	13/16	24	—	—	—	—	—
—	210	8-1/4	13/16	24	—	—	—	—	—
—	210	8-1/4	13/16	24	—	—	—	—	—
—	228	9	7/8	28	—	SC900	—	—	—
—	200	7-7/8	13/16	24	—	—	—	—	—
—	200	7-7/8	13/16	24	—	—	—	—	—
—	200	7-7/8	13/16	24	—	—	—	—	—
—	200	7-7/8	13/16	24	—	—	—	—	—
—	200	7-7/8	13/16	24	—	—	—	—	—
—	210	8-1/4	13/16	24	—	—	CC953	—	—
—	210	8-1/4	13/16	24	—	—	—	—	—
—	210	8-1/4	7/8	28	—	—	—	—	—
—	210	8-1/4	13/16	24	—	—	—	—	—
—	210	8-1/4	13/16	24	—	—	—	—	—
—	225	8-7/8	7/8	28	—	—	—	—	—
—	225	8-7/8	7/8	28	MC110	—	—	—	—
—	228	9	7/8	28	—	SC900	—	—	—
—	228	9	7/8	28	—	SC900	—	—	—
—	225	8-7/8	7/8	28	MC110	SC512	—	—	—
—	228	9	7/8	28	MC110	SC512	—	—	—
—	225	8-7/8	7/8	28	MC110	—	—	—	—
—	228	9	7/8	28	MC110	SC512	—	—	—
—	228	9	7/8	28	—	—	—	—	—
—	210	8-1/4	7/8	28	—	—	—	—	—
—	210	8-1/4	7/8	28	—	—	—	—	—
—	210	8-1/4	7/8	28	—	—	—	—	—
—	210	8-1/4	7/8	28	—	—	—	—	—
—	210	8-1/4	7/8	28	MC110	SC512	—	—	—
—	215	8-7/16	7/8	28	MC110	—	—	—	—
—	240	9-7/16	15/16	23	—	—	—	—	—
—	228	9	7/8	28	—	—	—	—	—
—	228	9	7/8	28	—	SC900	—	—	—
—	228	9	7/8	28	MC110	SC512	—	—	—
—	228	9	7/8	28	MC110	—	—	—	—
—	240	9-7/16	15/16	23	MC110	—	—	—	—
—	240	9-7/16	15/16	23	MC110	—	—	—	—

2

Liter	CC/IN	Cyl	Years		Application Information	Kit
			To	From		
VOLKSWAGEN continued						
<i>PASSAT</i>						
1.8	1781	L4	1998	1998	Turbo	VWK1001
1.8	1781	L4	1999	2001	Turbo	VWK1001
1.8	1781	L4	2002	2005	Turbo, Sold as Kit Only	VWK1001
1.9	1896	L4	1993	1994	Diesel	17034
1.9	1896	L4	1996	1997	Turbo Diesel	17034
2.0	1984	L4	1990	1993	—	17034
2.0	1984	L4	1994	1996	—	17034
2.0	1984	L4	2006	2007	Turbo, Includes Slave Cylinder, Sold as Kit Only	VWK1005
2.8	2792	V6	1993	1993	—	17036
2.8	2792	V6	1994	1997	—	17036
2.8	2771	V6	1998	2005	—	AUK1001
4.0	3998	W8	2003	2004	Sold as Kit Only	VWK1007
<i>QUANTUM</i>						
1.8	1780	L4	1984	1985	—	17031
2.2	2144	L5	1983	1984	Cable Release	17030
2.2	2226	L5	1985	1986	Cable Release	17030
2.2	2226	L5	1985	1988	Hydraulic Release	02011
<i>RABBIT</i>						
1.6	1588	L4	1981	1984	Diesel	17004
1.7	1715	L4	1981	1984	Gas with Rectangular Headlights	17004
1.8	1780	L4	1983	1983	GTI, 16 Valve	17027
1.8	1780	L4	1983	1984	Gas, 8 Valve	17012
2.5	2480	L5	2006	2008	Sold as Kit Only	VWK1004
<i>SCIROCCO</i>						
1.6	1588	L4	1980	1980	—	17004
1.8	1780	L4	1983	1989	8 Valve	17012
VOLKSWAGEN LIGHT TRUCK & VAN						
<i>CAMPMOBILE</i>						
1.7	1679	H4	1972	1973	—	17016
1.8	1795	H4	1974	1974	—	17016
1.8	1795	H4	1975	1975	—	17017
<i>EUROVAN</i>						
2.5	2459	L5	1993	1995	—	17036
<i>EUROVAN (CANADA)</i>						
2.5	2459	L5	1992	1995	—	17036
2.4	2370	L5	1996	1996	Diesel	17036
<i>RABBIT PICKUP</i>						
1.6	1588	L4	1980	1980	Gas	17004
1.6	1588	L4	1981	1983	Diesel	17004
1.7	1715	L4	1981	1983	—	17004
<i>TRANSPORTER</i>						
1.2	1192	H4	1954	1962	Rigid Disc	17015
1.7	1679	H4	1972	1973	—	17016
1.8	1795	H4	1974	1974	—	17016
1.8	1795	H4	1975	1975	—	17017
1.9	1915	H4	1985	1985	Syncro CANADA	17017
2.5	2459	L5	1992	1993	CANADA	17034
<i>VANAGON (TYPE II)</i>						
1.6	1588	L4	1982	1985	Diesel	17011

EXEDY OEM	Disc (mm)	Disc (in)	Spline Dia	Splines	Master Cylinder	Slave Cylinder	Clutch Cable	Clutch Fork	New Flywheel
—	228	9	15/16	23	MC108	—	—	—	—
—	228	9	15/16	23	—	—	—	—	—
—	228	9	15/16	23	—	—	—	—	—
—	228	9	7/8	28	MC106	SC511	—	—	—
—	228	9	7/8	28	MC106	SC511	—	—	—
—	228	9	7/8	28	MC103	SC511	—	—	—
—	228	9	7/8	28	MC106	SC511	—	—	—
—	240	9-7/16	15/16	23	—	—	—	—	—
—	228	9	7/8	28	MC103	SC511	—	—	—
—	228	9	7/8	28	MC106	SC511	—	—	—
—	240	9-7/16	15/16	23	MC108	—	—	—	—
—	240	9 7/16	15/16	23	—	—	—	—	—
—	210	8-1/4	13/16	24	—	—	—	—	—
—	215	8-1/2	13/16	24	—	—	—	—	—
—	215	8-1/2	13/16	24	—	—	—	—	—
—	228	9	13/16	24	MC101	SC509	—	—	—
—	200	7-7/8	13/16	24	—	—	—	—	—
—	200	7-7/8	13/16	24	—	—	—	—	—
—	210	8-1/4	7/8	28	—	—	—	—	—
—	210	8-1/4	13/16	24	—	—	CC953	—	—
—	228	9	7/8	28	—	—	—	—	—
—	200	7-7/8	13/16	24	—	—	—	—	—
—	210	8-1/4	13/16	24	—	—	—	—	—
—	210	8-1/4	13/16	24	—	—	—	—	—
—	210	8-1/4	13/16	24	—	—	—	—	—
—	215	8-7/16	13/16	24	—	—	—	—	—
—	228	9	7/8	28	MC105	SC900	—	—	—
—	228	9	7/8	28	MC105	SC900	—	—	—
—	228	9	7/8	28	MC105	SC900	—	—	—
—	200	7-7/8	13/16	24	—	—	—	—	—
—	200	7-7/8	13/16	24	—	—	—	—	—
—	200	7-7/8	13/16	24	—	—	—	—	—
—	184	7-1/4	13/16	24	—	—	—	—	—
—	210	8-1/4	13/16	24	—	—	—	—	—
—	210	8-1/4	13/16	24	—	—	—	—	—
—	215	8-7/16	13/16	24	—	—	—	—	—
—	215	8-7/16	13/16	24	MC133	SC536	—	—	—
—	228	9	7/8	28	—	—	—	—	—
—	215	8-1/2	13/16	24	MC133	SC876	—	—	—

2

Liter	CC/IN	Cyl	Years		Application Information	Kit
			To	From		
VOLVO						
240 SERIES						
2.1	2127	L4	1984	1984	Intercooled Turbo	22019
2.1	2127	L4	1985	1985	Intercooled Turbo with 9" Disc	22020
2.3	2316	L4	1987	1993	—	22021
2.4	2383	L6	1982	1984	Diesel	22015
260 SERIES						
2.4	2383	L6	1980	1981	Diesel	22007
2.7	2673	V6	1979	1979	Sold As Kit Only	KVO03
2.8	2849	V6	1980	1982	Sold As Kit Only	KVO03
740						
2.3	2316	L4	1985	1990	5 Spd, Non-Turbo	22021
2.3	2316	L4	1985	1992	Turbo with 9" Disc	22023
2.3	2316	L4	1990	1990	16 Valve, Non-Turbo	22023
2.4	2383	L6	1985	1985	Turbo Diesel	22015
2.4	2377	L6	1986	1986	Turbo Diesel	22015
760						
2.3	2316	L4	1985	1986	Turbo	22023
2.8	2849	V6	1985	1986	—	22015
C70						
2.3	2319	L5	2003	2003	Turbo, Sold as Kit Only, Includes CSC Hydraulic Slave Cylinder	VLK1003
S60						
2.3	2319	L5	2002	2004	Turbo, Sold as Kit Only, Includes CSC Hydraulic Slave Cylinder	VLK1003
2.4	2435	L5	2002	2003	Turbo, Sold as Kit Only, Includes CSC Hydraulic Slave Cylinder	VLK1003
V70						
2.3	2319	L5	2001	2004	Turbo, From Chassis # 395002, Sold as Kit Only, Includes CSC Hydraulic Slave Cylinder	VLK1003
2.4	2435	L5	2002	2003	Turbo, Sold as Kit Only, Includes CSC Hydraulic Slave Cylinder	VLK1003

EXEDY OEM	Disc (mm)	Disc (in)	Spline Dia	Splines	Master Cylinder	Slave Cylinder	Clutch Cable	Clutch Fork	New Flywheel
—	228	9	1	22	—	—	—	—	—
—	228	9	1	22	—	—	—	—	—
—	228	9	1	22	—	—	—	—	—
—	228	9	1	22	—	—	—	—	—
—	228	9	1	22	—	—	—	—	—
—	230	9-1/16	1	22	—	—	—	—	—
—	230	9-1/16	1	22	—	—	—	—	—
—	228	9	1	22	—	—	—	—	—
—	228	9	1	22	—	SC890	—	—	—
—	228	9	1	22	—	—	—	—	—
—	228	9	1	22	—	SC890	—	—	—
—	228	9	1	22	—	SC890	—	—	—
—	228	9	1	22	—	SC890	—	—	—
—	228	9	1	22	—	—	—	—	—
—	240	9-7/16	1	23	—	—	—	—	—
—	240	9-7/16	1	23	—	—	—	—	—
—	240	9-7/16	1	23	—	—	—	—	—
—	240	9-7/16	1	23	—	—	—	—	—
—	240	9-7/16	1	23	—	—	—	—	—



SECTION 3
MEDIUM DUTY
TRUCK
APPLICATIONS
GUIDE

2020-2021 Product Catalog **MEDIUM DUTY TRUCK APPLICATIONS**

Liter	cc / in	Cyl	Years	Application Information	Engine Number	Kit
CHEVROLET MEDIUM TRUCK						
<i>C40, 50, 60, 70</i>						
3.5L	212	4	1967-63	4-53 Detroit Diesel with Diaph Clutch		04106
3.5L	212	4	1967-63	4-53 Detroit Diesel with Diaph Clutch with Ceramic Button		04107
3.5L	212	4	1967-63	4-53 Detroit Diesel with Lever Clutch		GMK1002
3.8L	230	6	1969-63	12" Diaph Clutch		04064
3.8L	230	6	1969-63	12" Diaph Clutch with Ceramic Button		04105
3.8L	230	6	1969-63	12" Lever Clutch		04502
3.8L	230	6	1969-63	12" Lever Clutch with Ceramic Button		04517
3.8L	230	6	1969-63	13" Diaph Clutch		04106
3.8L	230	6	1969-63	13" Diaph Clutch with Ceramic Button		04107
3.8L	230	6	1969-63	13" Lever Clutch		GMK1002
3.8L	230	6	1969-63	13" Lever Clutch with Ceramic Button		GMK1003
3.9L	235	4	2001-98	w/ Hydro Brake Booster		KGM15
3.9L	235	4	2001-98	w/o Hydro Brake Booster, Heavy Duty Clutch, Silent Design Disc	4HE1	KGM16
3.9L	235	6	1962-54	12" Diaph Clutch		04064
3.9L	235	6	1962-54	12" Diaph Clutch with Ceramic Button		04105
3.9L	235	6	1962-54	12" Lever Clutch		04502
3.9L	235	6	1962-54	12" Lever Clutch with Ceramic Button		04517
4.3L	261	6	1962-55	12" Diaph Clutch		04064
4.3L	261	6	1962-55	12" Diaph Clutch with Ceramic Button		04105
4.3L	261	6	1962-55	12" Lever Clutch		04502
4.3L	261	6	1962-55	12" Lever Clutch with Ceramic Button		04517
4.6L	283	8	1970-56	13" Diaph Clutch		04106
4.6L	283	8	1970-56	13" Diaph Clutch with Ceramic Button		04107
4.6L	283	8	1970-56	13" Lever Clutch		GMK1002
4.6L	283	8	1970-56	13" Lever Clutch with Ceramic Button		GMK1003
4.8L	292	6	1989-63	12" Diaph Clutch		04064
4.8L	292	6	1989-63	12" Diaph Clutch with Ceramic Button		04105
4.8L	292	6	1989-63	12" Lever Clutch		04502
4.8L	292	6	1989-63	12" Lever Clutch with Ceramic Button		04517
4.8L	292	6	1989-63	13" Diaph Clutch		04106
4.8L	292	6	1989-63	13" Diaph Clutch with Ceramic Button		04107
4.8L	292	6	1989-63	13" Lever Clutch		GMK1002
4.8L	292	6	1989-63	13" Lever Clutch with Ceramic Button		GMK1003
5.2L	321	8	1968-64	13" Diaph Clutch		04106
5.2L	321	8	1968-64	13" Diaph Clutch with Ceramic Button		04107
5.2L	321	8	1968-64	13" Lever Clutch		GMK1002
5.2L	321	8	1968-64	13" Lever Clutch with Ceramic Button		GMK1003
5.4L	327	8	1972-62	13" Diaph Clutch		04106
5.4L	327	8	1972-62	13" Diaph Clutch with Ceramic Button		04107
5.4L	327	8	1972-62	13" Lever Clutch		GMK1002
5.4L	327	8	1972-62	13" Lever Clutch with Ceramic Button		GMK1003
5.7L	348	8	1972-62	13" Diaph Clutch		04106
5.7L	348	8	1972-62	13" Diaph Clutch with Ceramic Button		04107
5.7L	348	8	1972-62	13" Lever Clutch		GMK1002
5.7L	348	8	1972-62	13" Lever Clutch with Ceramic Button		GMK1003
5.7L	350	8	1989-65	12" Lever Clutch		04502
5.7L	350	8	1989-65	12" Lever Clutch		04502
5.7L	350	8	1989-65	12" Lever Clutch with Ceramic Button		04517
5.7L	350	8	1989-65	12" Lever Clutch with Ceramic Button		04517
5.7L	350	8	1993-85	13" Clutch		04149
5.7L	350	8	1993-85	13" Clutch with Ceramic Button		04150
5.7L	350	8	1993-73	13" Diaph Clutch		04106
5.7L	350	8	1972-65	13" Diaph Clutch		04106
5.7L	350	8	1972-65	13" Diaph Clutch with Ceramic Button		04107
5.7L	350	8	1993-73	13" Diaph Clutch with Ceramic Button		04107
5.7L	350	8	1972-65	13" Lever Clutch		GMK1002
5.7L	350	8	1993-73	13" Lever Clutch		GMK1002
5.7L	350	8	1993-73	13" Lever Clutch with Ceramic Button		GMK1003
5.7L	350	8	1972-65	13" Lever Clutch with Ceramic Button		GMK1003

3

MEDIUM DUTY TRUCK APPLICATIONS 2020-2021 Product Catalog

Cover	Disc	Rel Brg	Disc (mm)	Disc (in)	Spline Dia	Splines	Master Cyl	Slave Cyl	Clutch Cable	Clutch Fork	New Flywheel
—	—	—	330	13	1-1/2	10	—	—	—	—	—
—	—	—	330	13	1-1/2	10	—	—	—	—	—
—	—	—	330	13	1-1/2	10	—	—	—	—	—
—	—	—	300	11-3/4	1-1/8	10	—	—	—	—	—
—	—	—	300	11-3/4	1-1/8	10	—	—	—	—	—
—	—	—	300	11-3/4	1-1/8	10	—	—	—	—	—
—	—	—	300	11-3/4	1-1/8	10	—	—	—	—	—
—	—	—	330	13	1-1/2	10	—	—	—	—	—
—	—	—	330	13	1-1/2	10	—	—	—	—	—
—	—	—	330	13	1-1/2	10	—	—	—	—	—
—	—	—	330	13	1-1/2	10	—	—	—	—	—
—	—	—	324	12-3/4	1-1/2	10	—	—	—	—	—
—	—	—	300	11-13/16	1-1/8	21	—	—	—	—	—
—	—	—	300	11-3/4	1-1/8	10	—	—	—	—	—
—	—	—	300	11-3/4	1-1/8	10	—	—	—	—	—
—	—	—	300	11-3/4	1-1/8	10	—	—	—	—	—
—	—	—	300	11-3/4	1-1/8	10	—	—	—	—	—
—	—	—	300	11-3/4	1-1/8	10	—	—	—	—	—
—	—	—	300	11-3/4	1-1/8	10	—	—	—	—	—
—	—	—	300	11-3/4	1-1/8	10	—	—	—	—	—
—	—	—	300	11-3/4	1-1/8	10	—	—	—	—	—
—	—	—	330	13	1-1/2	10	—	—	—	—	—
—	—	—	330	13	1-1/2	10	—	—	—	—	—
—	—	—	330	13	1-1/2	10	—	—	—	—	—
—	—	—	330	13	1-1/2	10	—	—	—	—	—
—	—	—	300	11-3/4	1-1/8	10	—	—	—	—	—
—	—	—	300	11-3/4	1-1/8	10	—	—	—	—	—
—	—	—	300	11-3/4	1-1/8	10	—	—	—	—	—
—	—	—	300	11-3/4	1-1/8	10	—	—	—	—	—
—	—	—	330	13	1-1/2	10	—	—	—	—	—
—	—	—	330	13	1-1/2	10	—	—	—	—	—
—	—	—	330	13	1-1/2	10	—	—	—	—	—
—	—	—	330	13	1-1/2	10	—	—	—	—	—
—	—	—	330	13	1-1/2	10	—	—	—	—	—
—	—	—	330	13	1-1/2	10	—	—	—	—	—
—	—	—	330	13	1-1/2	10	—	—	—	—	—
—	—	—	330	13	1-1/2	10	—	—	—	—	—
—	—	—	330	13	1-1/2	10	—	—	—	—	—
—	—	—	330	13	1-1/2	10	—	—	—	—	—
—	—	—	330	13	1-1/2	10	—	—	—	—	—
—	—	—	330	13	1-1/2	10	—	—	—	—	—
—	—	—	330	13	1-1/2	10	—	—	—	—	—
—	—	—	330	13	1-1/2	10	—	—	—	—	—
—	—	—	330	13	1-1/2	10	—	—	—	—	—
—	—	—	330	13	1-1/2	10	—	—	—	—	—
—	—	—	330	13	1-1/2	10	—	—	—	CF127	—
—	—	—	330	13	1-1/2	10	—	—	—	—	—
—	—	—	330	13	1-1/2	10	—	—	—	—	—
—	—	—	330	13	1-1/2	10	—	—	—	—	—
—	—	—	330	13	1-1/2	10	—	—	—	—	—
—	—	—	330	13	1-1/2	10	—	—	—	CF127	—
—	—	—	330	13	1-1/2	10	—	—	—	CF127	—
—	—	—	330	13	1-1/2	10	—	—	—	—	—

2020-2021 Product Catalog **MEDIUM DUTY TRUCK APPLICATIONS**

Liter	cc / in	Cyl	Years	Application Information	Engine Number	Kit
-------	---------	-----	-------	-------------------------	---------------	-----

CHEVROLET MEDIUM TRUCK CONT.

C40, 50, 60, 70 CONT.

6.0L	366	8	1998-90	13" Clutch		04149
6.0L	366	8	1998-90	13" Clutch with Ceramic Button		04150
6.0L	366	8	1968-65	13" Diaph Clutch		04106
6.0L	366	8	1989-69	13" Diaph Clutch		04106
6.0L	366	8	1968-65	13" Diaph Clutch with Ceramic Button		04107
6.0L	366	8	1989-69	13" Diaph Clutch with Ceramic Button		04107
6.0L	366	8	1989-69	13" Lever Clutch		GMK1002
6.0L	366	8	1968-65	13" Lever Clutch		GMK1002
6.0L	366	8	1968-65	13" Lever Clutch with Ceramic Button		GMK1003
6.0L	366	8	1989-69	13" Lever Clutch with Ceramic Button		GMK1003
6.7L	409	8	1972-62	13" Diaph Clutch		04106
6.7L	409	8	1972-62	13" Diaph Clutch with Ceramic Button		04107
6.7L	409	8	1972-62	13" Lever Clutch		GMK1002
6.7L	409	8	1972-62	13" Lever Clutch with Ceramic Button		GMK1003
7.0L	427	8	1993-90	13" Clutch		04149
7.0L	427	8	1993-90	13" Clutch with Ceramic Button		04150
7.0L	427	8	1989-65	13" Diaph Clutch		04106
7.0L	427	8	1989-65	13" Diaph Clutch with Ceramic Button		04107
7.0L	427	8	1989-65	13" Lever Clutch		GMK1002
7.0L	427	8	1989-65	13" Lever Clutch with Ceramic Button		GMK1003
7.0L	427	8	2001-94	Gas, Valeo Push Type Clutch		KGM40
7.2L	439	6	2006-90	Cat 3116, 3169 with Eaton Transmission, Pull style		KGM41
7.2L	439	6	2001-97	Cat 3126 Turbo with Eaton Transmission		KGM42
7.2L	439	8	2001-94	CAT 3116/31126 with Eaton Transmission		KGM41
7.2L	439	8	1999-90	CAT 3126 with Eaton Transmission, T Series		KGM42

TILTMASTER W4000 , W7000

3.9L	3900	4	1997-91			KGM20
3.9L	3900	4	1986-84	Turbo Diesel		09011
3.9L	3900	4	1986-84	Turbo Diesel, with Ceramic Button		KIS03
3.9L	3900	4	2001-98	w Hydro Brake Booster	4HE1	KGM15
3.9L	3900	4	2001-98	w/o Hydro Brake Booster, Heavy Duty Clutch, Silent Design Disc	4HE1	KGM16
3.9L	3900	4	1990-87	W4000, Turbo	4BD1, 4BD2	KGM14
5.8L	5800	8	2002-84	W7000	6BD1T	KIS02

DODGE MEDIUM TRUCK

D400, 500

5.2L	318	8	1982-60			05047
5.8L	354	8	1982-67	Diesel		05047
5.9L	361	8	1982-67			05047

FORD MEDIUM TRUCK

F400, 450, 500, 550, 600, 700, 800, 900, 1000

3.8L	232	6	1983			07016
3.8L	232	6	1982-81			07014
3.9L	240	6	1976-55	Diaph Clutch		KFM10
3.9L	240	6	1976-55	Lever Clutch		07027
4.2L	255	6	2005-97			KFM12
4.9L	300	6	1979-65	11" Diaph Clutch		KFM10
4.9L	300	6	1979-65	11" Lever Clutch		07027
4.9L	300	6	1972-66	13" Clutch		07125
4.9L	300	6	1979-73	13" Clutch		07125
4.9L	300	6	1972-66	13" Clutch with Ceramic Button		07126
4.9L	300	6	1979-73	13" Clutch with Ceramic Button		07126
5.4L	330	8	1986-55	13" Clutch		07125
5.4L	330	8	1986-55	13" Clutch with Ceramic Button		07126
5.9L	359	8	1986-67	13" Clutch		07125
5.9L	359	8	1986-67	13" Clutch with Ceramic Button		07126
5.9L	361	8	1986-55	13" Clutch		07125
5.9L	361	8	1986-55	13" Clutch with Ceramic Button		07126

MEDIUM DUTY TRUCK APPLICATIONS 2020-2021 Product Catalog

Cover	Disc	Rel Brg	Disc (mm)	Disc (in)	Spline Dia	Splines	Master Cyl	Slave Cyl	Clutch Cable	Clutch Fork	New Flywheel
—	—	—	330	13	1-1/2	10	—	—	—	CF127	FWGM16
—	—	—	330	13	1-1/2	10	—	—	—	CF127	FWGM16
—	—	—	330	13	1-1/2	10	—	—	—	—	—
—	—	—	330	13	1-1/2	10	—	—	—	CF127	FWGM16
—	—	—	330	13	1-1/2	10	—	—	—	—	—
—	—	—	330	13	1-1/2	10	—	—	—	CF127	FWGM16
—	—	—	330	13	1-1/2	10	—	—	—	CF127	FWGM16
—	—	—	330	13	1-1/2	10	—	—	—	—	—
—	—	—	330	13	1-1/2	10	—	—	—	CF127	FWGM16
—	—	—	330	13	1-1/2	10	—	—	—	—	—
—	—	—	330	13	1-1/2	10	—	—	—	—	—
—	—	—	330	13	1-1/2	10	—	—	—	—	—
—	—	—	330	13	1-1/2	10	—	—	—	—	—
—	—	—	330	13	1-1/2	10	—	—	—	—	—
—	—	—	330	13	1-1/2	10	—	—	—	—	—
—	—	—	330	13	1-1/2	10	—	—	—	—	—
—	—	—	330	13	1-1/2	10	—	—	—	—	—
—	—	—	330	13	1-1/2	10	—	—	—	—	—
—	—	—	330	13	1-1/2	10	—	—	—	—	—
—	—	—	330	13	1-1/2	10	—	—	—	—	—
—	—	—	330	13	1-1/2	10	—	—	—	—	—
—	—	—	356	14	1-3/4	10	—	—	—	—	—
—	—	—	356	14	1-3/4	10	—	—	—	—	—
—	—	—	356	14	1-3/4	10	—	—	—	—	—
—	—	—	356	14	1-3/4	10	—	—	—	—	—
—	—	—	300	11-13/16	1-1/8	21	—	—	—	—	—
—	—	—	273	10-3/4	1	24	—	—	—	—	—
—	—	—	273	10-3/4	1	24	—	—	—	—	—
—	—	—	324	12-3/4	1-1/2	10	—	—	—	—	—
—	—	—	300	11-13/16	1-1/8	21	—	—	—	—	—
—	—	—	300	11-13/16	1	24	—	—	—	—	—
—	—	—	356	14	1-1/2	10	—	—	—	—	—
CA1919	CD3734	N1484	330	13	1-3/8	10	—	—	—	—	—
CA1919	CD3734	N1484	330	13	1-3/8	10	—	—	—	—	—
CA1919	CD3734	N1484	330	13	1-3/8	10	—	—	—	—	—
CA0030	CD4184	N1714SA	254	10	1-1/16	10	—	—	—	—	—
CA0030	CD4184	N1439SA	254	10	1-1/16	10	—	—	—	—	—
FMC903	FMD808	N1714SA	280	11	1-1/16	10	—	—	—	—	—
CA0465	CD1226	N1439SA	280	11	1-1/16	10	—	—	—	—	—
CA1947	CD1947	N8134	290	11-1/2	1-1/16	10	—	—	—	—	—
FMC903	FMD808	N1714SA	280	11	1-1/16	10	—	—	—	—	—
CA0465	CD1226	N1439SA	280	11	1-1/16	10	—	—	—	—	—
CA1919	CD0629	N1495	330	13	1-3/8	10	—	—	—	—	—
CA1919	CD0629	N1495	330	13	1-3/8	10	—	—	—	—	FWFM121
CA1919	CD0629CB	N1495	330	13	1-3/8	10	—	—	—	—	—
CA1919	CD0629CB	N1495	330	13	1-3/8	10	—	—	—	—	FWFM121
CA1919	CD0629	N1495	330	13	1-3/8	10	—	—	—	—	—
CA1919	CD0629CB	N1495	330	13	1-3/8	10	—	—	—	—	—
CA1919	CD0629	N1495	330	13	1-3/8	10	—	—	—	—	—
CA1919	CD0629CB	N1495	330	13	1-3/8	10	—	—	—	—	—
CA1919	CD0629	N1495	330	13	1-3/8	10	—	—	—	—	—
CA1919	CD0629CB	N1495	330	13	1-3/8	10	—	—	—	—	—

3

2020-2021 Product Catalog MEDIUM DUTY TRUCK APPLICATIONS

Liter	cc / in	Cyl	Years	Application Information	Engine Number	Kit
FORD MEDIUM TRUCK CONT.						
<i>F400, 450, 500, 550, 600, 700, 800, 900, 1000 CONT.</i>						
6.0L	363	8	1982-79	13" Clutch		07125
6.0L	363	8	1982-79	13" Clutch with Ceramic Button		07126
6.1L	370	8	1988-79	13" Clutch		07125
6.1L	370	8	1993-89	13" Clutch		07125
6.1L	370	8	1988-79	13" Clutch with Ceramic Button		07126
6.1L	370	8	1993-89	13" Clutch with Ceramic Button		07126
6.4L	389	8	1979-65	13" Clutch		07125
6.4L	389	8	1979-65	13" Clutch with Ceramic Button		07126
6.4L	391	8	1978-65	13" Clutch		07125
6.4L	391	8	1978-65	13" Clutch with Ceramic Button		07126
6.8L	415	10	2003-99			KFM21
7.0L	429	8	1986-79	13" Clutch		07125
7.0L	429	8	1993-87	13" Clutch		07125
7.0L	429	8	1993-87	13" Clutch with Ceramic Button		07126
7.0L	429	8	1986-79	13" Clutch with Ceramic Button		07126
7.3L	446	8	1998-94	5 Spd with Direct Fuel Injection, VIN F. LUK Type Solid Flywheel and mounting bolts included.		KFM18A
7.3L	446	8	1998-94	5 Spd with Direct Fuel Injection, VIN F. LUK Type Solid Flywheel not Included. Use this kit when solid flywheel is present.		KFM18
7.3L	446	8	1998-94	5 Spd with Direct Fuel Injection. Valeo Type Solid Flywheel Replacement Kit Includes Flywheel and Mounting Bolts.		KFM15A
7.3L	446	8	2003-99	6 Spd with direct fuel injection and Valeo OE solid flywheel. Valeo type solid flywheel included.		KFM17A
7.3L	446	8	2003-99	6 Spd with direct fuel injection and Valeo OE solid flywheel. Valeo type solid flywheel not included.		KFM17
7.3L	446	8	2003-99	Turbo Diesel 6 speed with direct fuel injection and LUK OE solid flywheel. LUK type solid flywheel is included. This kit must be installed as a matched set.		KFM16A
7.3L	446	8	1998-94	With Indirect Fuel Injection, Factory Turbo, with DMF. Heavy Duty 12" option. Valeo type DMF included.		07100B
7.3L	446	8	1993-87	With Indirect Fuel Injection, Factory Turbo, with DMF. Heavy Duty 12" option. Valeo type DMF included.		07100B
7.3L	446	8	1993-87	With Indirect Fuel Injection, Non-Turbo and Aftermarket Turbo, with DMF. Valeo type DMF included.		07076A
7.3L	446	8	1998-94	With Indirect Fuel Injection, Non-Turbo and Aftermarket Turbo, with DMF. Valeo type DMF included.		07076A
7.3L	446	8	1993-87	With Indirect Fuel Injection, Non-Turbo and Aftermarket Turbo, with DMF. Valeo type DMF not included. With Stripped chassis.		07076
7.3L	446	8	1998-94	With Indirect Fuel Injection, Non-Turbo and Aftermarket Turbo, with DMF. Valeo type DMF not included. With Stripped chassis.		07076
7.3L	446	8	1993-87	With Indirect Fuel Injection, Non-Turbo and Aftermarket Turbo, with DMF. Heavy Duty 12" option with rigid disc. Valeo type DMF included.		07100A
7.3L	446	8	1998-94	With Indirect Fuel Injection, Non-Turbo and Aftermarket Turbo, with DMF. Heavy Duty 12" option with rigid disc. Valeo type DMF included.		07100A
7.3L	446	8	1998-94	With Indirect Fuel Injection, Non-Turbo and Aftermarket Turbo, with DMF. Heavy Duty 12" option. Valeo type DMF not included.		07100

MEDIUM DUTY TRUCK APPLICATIONS 2020-2021 Product Catalog

Cover	Disc	Rel Brg	Disc (mm)	Disc (in)	Spline Dia	Splines	Master Cyl	Slave Cyl	Clutch Cable	Clutch Fork	New Flywheel
CA1919	CD0629	N1495	330	13	1-3/8	10	—	—	—	—	—
CA1919	CD0629CB	N1495	330	13	1-3/8	10	—	—	—	—	—
CA1919	CD0629	N1495	330	13	1-3/8	10	—	—	—	CF122	—
CA1919	CD0629	N1495	330	13	1-3/8	10	—	—	—	—	—
CA1919	CD0629CB	N1495	330	13	1-3/8	10	—	—	—	CF122	—
CA1919	CD0629CB	N1495	330	13	1-3/8	10	—	—	—	—	—
CA1919	CD0629	N1495	330	13	1-3/8	10	—	—	—	—	—
CA1919	CD0629CB	N1495	330	13	1-3/8	10	—	—	—	—	—
CA1919	CD0629	N1495	330	13	1-3/8	10	—	—	—	—	—
CA1919	CD0629CB	N1495	330	13	1-3/8	10	—	—	—	—	—
CA2053	CD2069	N8126	305	12	1-1/4	10	—	—	—	—	—
CA1919	CD0629	N1495	330	13	1-3/8	10	—	—	—	CF122	—
CA1919	CD0629	N1495	330	13	1-3/8	10	—	—	—	—	—
CA1919	CD0629CB	N1495	330	13	1-3/8	10	—	—	—	—	—
CA1919	CD0629CB	N1495	330	13	1-3/8	10	—	—	—	CF122	—
LMX107X	Modular	N1753	330	13	1-1/4	10	MC362	SC735	—	—	—
LMX107X	Modular	N1753	330	13	1-1/4	10	MC362	SC735	—	—	—
LMS107V	Modular	N1753	330	13	1-1/4	10	MC362	SC735	—	—	—
CA2442	CD3578	N8126	330	13	1-1/4	10	MC356	SC738	—	—	—
CA2442	CD3578	N8126	330	13	1-1/4	10	MC356	SC738	—	—	—
LMS108	Modular	N8126	330	13	1-3/8	10	—	—	—	—	—
CA5081	CD5081	N1753	302	11-7/8	1-1/4	10	MC362	SC735	—	—	—
CA5081	CD5081	N1753	302	11-7/8	1-1/4	10	MC356	SC720	—	—	—
CA0065	CD1064	N1753	280	11	1-1/4	10	MC356	SC720	—	—	—
CA0065	CD1064	N1753	280	11	1-1/4	10	MC362	SC735	—	—	—
CA0065	CD1064	N1753	280	11	1-1/4	10	MC356	SC735	—	—	—
CA0065	CD1064	N1753	280	11	1-1/4	10	MC356	SC735	—	—	—
CA5081	CD5081	N1753	302	11-7/8	1-1/4	10	MC356	SC720	—	—	—
CA5081	CD5081	N1753	302	11-7/8	1-1/4	10	MC362	SC735	—	—	—
CA5081	CD5081	N1753	302	11-7/8	1-1/4	10	MC362	SC735	—	—	—

2020-2021 Product Catalog **MEDIUM DUTY TRUCK APPLICATIONS**

Liter	cc / in	Cyl	Years	Application Information	Engine Number	Kit
-------	---------	-----	-------	-------------------------	---------------	-----

FORD MEDIUM TRUCK CONT.

F400, 450, 500, 550, 600, 700, 800, 900, 1000 CONT.

7.3L	446	8	1993-87	With Indirect Fuel Injection, Non-Turbo and Aftermarket Turbo, with DMF. Heavy Duty 12" option. Valeo type DMF not included.		07100
7.3L	446	8	1998-94	With Indirect Fuel Injection, Non-Turbo and Factory Turbo, 8th Digit of VIN K or M. LUK type solid flywheel replacement kit contains solid flywheel and mounting bolts. Must be used as matched set.		07131A
7.3L	446	8	1993-87	With Indirect Fuel Injection, Non-Turbo and Factory Turbo, 8th Digit of VIN K or M. LUK type solid flywheel replacement kit contains solid flywheel and mounting bolts. Must be used as matched set.		07131A
7.3L	446	8	1998-94	With Indirect Fuel Injection, Non-Turbo and Factory Turbo, 8th Digit of VIN K. LUK type solid flywheel replacement kit contains solid flywheel and mounting bolts. Must be used as matched set.		07131B
7.3L	446	8	1993-87	With Indirect Fuel Injection, Non-Turbo and Factory Turbo, 8th Digit of VIN K. LUK type solid flywheel replacement kit contains solid flywheel and mounting bolts. Must be used as matched set.		07131B
7.3L	446	8	1993-87	With Indirect Fuel Injection, Non-Turbo and Factory Turbo, LUK type solid flywheel replacement, kit does not contain flywheel.		07131
7.7L	471	8	1984-63	13" Clutch		07125
7.7L	471	8	1984-63	13" Clutch with Ceramic Button		07126
7.8L	477	8	1984-63	13" Clutch		07125
7.8L	477	8	1984-63	13" Clutch with Ceramic Button		07126

GMC MEDIUM TRUCK

C55, 65, 75

3.5L	212	4	1967-63	4-53 Detroit Diesel with Diaph Clutch		04106
3.5L	212	4	1967-63	4-53 Detroit Diesel with Diaph Clutch with Ceramic Button		04107
3.5L	212	4	1967-63	4-53 Detroit Diesel with Lever Clutch		GMK1002
3.8L	230	6	1969-63	12" Diaph Clutch		04064
3.8L	230	6	1969-63	12" Diaph Clutch with Ceramic Button		04105
3.8L	230	6	1969-63	12" Lever Clutch		04502
3.8L	230	6	1969-63	12" Lever Clutch with Ceramic Button		04517
3.8L	230	6	1969-63	13" Diaph Clutch		04106
3.8L	230	6	1969-63	13" Diaph Clutch with Ceramic Button		04107
3.8L	230	6	1969-63	13" Lever Clutch		GMK1002
3.8L	230	6	1969-63	13" Lever Clutch with Ceramic Button		GMK1003
3.9L	235	4	2001-98	w/ Hydro Brake Booster		KGM15
3.9L	235	4	2001-98	w/o Hydro Brake Booster, Heavy Duty Clutch, Silent Design Disc	4HE1	KGM16
3.9L	235	6	1962-54	12" Diaph Clutch		04064
3.9L	235	6	1962-54	12" Diaph Clutch with Ceramic Button		04105
3.9L	235	6	1962-54	12" Lever Clutch		04502
3.9L	235	6	1962-54	12" Lever Clutch with Ceramic Button		04517
4.3L	261	6	1962-55	12" Diaph Clutch		04064
4.3L	261	6	1962-55	12" Diaph Clutch with Ceramic Button		04105
4.3L	261	6	1962-55	12" Lever Clutch		04502
4.3L	261	6	1962-55	12" Lever Clutch with Ceramic Button		04517
4.6L	283	8	1970-56	13" Diaph Clutch		04106
4.6L	283	8	1970-56	13" Diaph Clutch with Ceramic Button		04107
4.6L	283	8	1970-56	13" Lever Clutch		GMK1002
4.6L	283	8	1970-56	13" Lever Clutch with Ceramic Button		GMK1003
4.8L	292	6	1989-63	12" Diaph Clutch		04064

MEDIUM DUTY TRUCK APPLICATIONS 2020-2021 Product Catalog

Cover	Disc	Rel Brg	Disc (mm)	Disc (in)	Spline Dia	Splines	Master Cyl	Slave Cyl	Clutch Cable	Clutch Fork	New Flywheel
CA5081	CD5081	N1753	302	11-7/8	1-1/4	10	MC356	SC720	—	—	—
LMS105X	—	N1753	311	12-1/4	1-1/4	10	MC362	SC735	—	—	—
LMS105X	—	N1753	311	12-1/4	1-1/4	10	MC356	SC720	—	—	—
LMS105X	—	N1753	311	12-1/4	1-1/4	10	MC362	SC735	—	—	—
LMS105X	—	N1753	311	12-1/4	1-1/4	10	MC356	SC720	—	—	—
LMS105X	—	N1753	311	12-1/4	1-1/4	10	MC356	SC720	—	—	—
CA1919	CD0629	N1495	330	13	1-3/8	10	—	—	—	—	—
CA1919	CD0629CB	N1495	330	13	1-3/8	10	—	—	—	—	—
CA1919	CD0629	N1495	330	13	1-3/8	10	—	—	—	—	—
CA1919	CD0629CB	N1495	330	13	1-3/8	10	—	—	—	—	—
—	—	—	330	13	1-1/2	10	—	—	—	—	—
—	—	—	330	13	1-1/2	10	—	—	—	—	—
—	—	—	330	13	1-1/2	10	—	—	—	—	—
—	—	—	300	11-3/4	1-1/8	10	—	—	—	—	—
—	—	—	300	11-3/4	1-1/8	10	—	—	—	—	—
—	—	—	300	11-3/4	1-1/8	10	—	—	—	—	—
—	—	—	300	11-3/4	1-1/8	10	—	—	—	—	—
—	—	—	330	13	1-1/2	10	—	—	—	—	—
—	—	—	330	13	1-1/2	10	—	—	—	—	—
—	—	—	330	13	1-1/2	10	—	—	—	—	—
—	—	—	330	13	1-1/2	10	—	—	—	—	—
—	—	—	324	12-3/4	1-1/2	10	—	—	—	—	—
—	—	—	300	11-13/16	1-1/8	21	—	—	—	—	—
—	—	—	300	11-3/4	1-1/8	10	—	—	—	—	—
—	—	—	300	11-3/4	1-1/8	10	—	—	—	—	—
—	—	—	300	11-3/4	1-1/8	10	—	—	—	—	—
—	—	—	300	11-3/4	1-1/8	10	—	—	—	—	—
—	—	—	300	11-3/4	1-1/8	10	—	—	—	—	—
—	—	—	300	11-3/4	1-1/8	10	—	—	—	—	—
—	—	—	300	11-3/4	1-1/8	10	—	—	—	—	—
—	—	—	300	11-3/4	1-1/8	10	—	—	—	—	—
—	—	—	330	13	1-1/2	10	—	—	—	—	—
—	—	—	330	13	1-1/2	10	—	—	—	—	—
—	—	—	330	13	1-1/2	10	—	—	—	—	—
—	—	—	330	13	1-1/2	10	—	—	—	—	—
—	—	—	300	11-3/4	1-1/8	10	—	—	—	—	—

2020-2021 Product Catalog **MEDIUM DUTY TRUCK APPLICATIONS**

Liter	cc / in	Cyl	Years	Application Information	Engine Number	Kit
GMC MEDIUM TRUCK CONT.						
<i>C55, 65, 75 CONT.</i>						
4.8L	292	6	1989-63	12" Diaph Clutch with Ceramic Button		04105
4.8L	292	6	1989-63	12" Lever Clutch		04502
4.8L	292	6	1989-63	12" Lever Clutch with Ceramic Button		04517
4.8L	292	6	1989-63	13" Diaph Clutch		04106
4.8L	292	6	1989-63	13" Diaph Clutch with Ceramic Button		04107
4.8L	292	6	1989-63	13" Lever Clutch		GMK1002
4.8L	292	6	1989-63	13" Lever Clutch with Ceramic Button		GMK1003
5.2L	321	8	1968-64	13" Diaph Clutch		04106
5.2L	321	8	1968-64	13" Diaph Clutch with Ceramic Button		04107
5.2L	321	8	1968-64	13" Lever Clutch		GMK1002
5.2L	321	8	1968-64	13" Lever Clutch with Ceramic Button		GMK1003
5.4L	327	8	1972-62	13" Diaph Clutch		04106
5.4L	327	8	1972-62	13" Diaph Clutch with Ceramic Button		04107
5.4L	327	8	1972-62	13" Lever Clutch		GMK1002
5.4L	327	8	1972-62	13" Lever Clutch with Ceramic Button		GMK1003
5.7L	348	8	1972-62	13" Diaph Clutch		04106
5.7L	348	8	1972-62	13" Diaph Clutch with Ceramic Button		04107
5.7L	348	8	1972-62	13" Lever Clutch		GMK1002
5.7L	348	8	1972-62	13" Lever Clutch with Ceramic Button		GMK1003
5.7L	350	8	1989-65	12" Lever Clutch		04502
5.7L	350	8	1989-65	12" Lever Clutch		04502
5.7L	350	8	1989-65	12" Lever Clutch with Ceramic Button		04517
5.7L	350	8	1989-65	12" Lever Clutch with Ceramic Button		04517
5.7L	350	8	1993-85	13" Clutch		04149
5.7L	350	8	1993-85	13" Clutch with Ceramic Button		04150
5.7L	350	8	1972-65	13" Diaph Clutch		04106
5.7L	350	8	1993-73	13" Diaph Clutch		04106
5.7L	350	8	1972-65	13" Diaph Clutch with Ceramic Button		04107
5.7L	350	8	1993-73	13" Diaph Clutch with Ceramic Button		04107
5.7L	350	8	1972-65	13" Lever Clutch		GMK1002
5.7L	350	8	1993-73	13" Lever Clutch		GMK1002
5.7L	350	8	1972-65	13" Lever Clutch with Ceramic Button		GMK1003
5.7L	350	8	1993-73	13" Lever Clutch with Ceramic Button		GMK1003
6.0L	366	8	1998-90	13" Clutch		04149
6.0L	366	8	1998-90	13" Clutch with Ceramic Button		04150
6.0L	366	8	1968-65	13" Diaph Clutch		04106
6.0L	366	8	1989-69	13" Diaph Clutch		04106
6.0L	366	8	1968-65	13" Diaph Clutch with Ceramic Button		04107
6.0L	366	8	1989-69	13" Diaph Clutch with Ceramic Button		04107
6.0L	366	8	1989-69	13" Lever Clutch		GMK1002
6.0L	366	8	1968-65	13" Lever Clutch		GMK1002
6.0L	366	8	1989-69	13" Lever Clutch with Ceramic Button		GMK1003
6.0L	366	8	1968-65	13" Lever Clutch with Ceramic Button		GMK1003
6.7L	409	8	1972-62	13" Diaph Clutch		04106
6.7L	409	8	1972-62	13" Diaph Clutch with Ceramic Button		04107
6.7L	409	8	1972-62	13" Lever Clutch		GMK1002
6.7L	409	8	1972-62	13" Lever Clutch with Ceramic Button		GMK1003
7.0L	427	8	1993-90	13" Clutch		04149
7.0L	427	8	1993-90	13" Clutch with Ceramic Button		04150
7.0L	427	8	1989-65	13" Diaph Clutch		04106
7.0L	427	8	1989-65	13" Diaph Clutch with Ceramic Button		04107
7.0L	427	8	1989-65	13" Lever Clutch		GMK1002
7.0L	427	8	1989-65	13" Lever Clutch with Ceramic Button		GMK1003
7.0L	427	8	2001-94	Gas, Valeo Push Type Clutch		KGM40
7.2L	439	6	2006-90	Cat 3116, 3169 with Eaton Transmission		KGM41
7.2L	439	6	2001-97	Cat 3126 Turbo with Eaton Transmission		KGM42
7.2L	439	8	2001-94	CAT 3116/31126 with Eaton Transmission		KGM41
7.2L	439	8	1999-90	CAT 3126 with Eaton Transmission, T Series		KGM42

3

MEDIUM DUTY TRUCK APPLICATIONS 2020-2021 Product Catalog

Cover	Disc	Rel Brg	Disc (mm)	Disc (in)	Spline Dia	Splines	Master Cyl	Slave Cyl	Clutch Cable	Clutch Fork	New Flywheel
—	—	—	300	11-3/4	1-1/8	10	—	—	—	—	—
—	—	—	300	11-3/4	1-1/8	10	—	—	—	—	—
—	—	—	300	11-3/4	1-1/8	10	—	—	—	—	—
—	—	—	330	13	1-1/2	10	—	—	—	—	—
—	—	—	330	13	1-1/2	10	—	—	—	—	—
—	—	—	330	13	1-1/2	10	—	—	—	—	—
—	—	—	330	13	1-1/2	10	—	—	—	—	—
—	—	—	330	13	1-1/2	10	—	—	—	—	—
—	—	—	330	13	1-1/2	10	—	—	—	—	—
—	—	—	330	13	1-1/2	10	—	—	—	—	—
—	—	—	330	13	1-1/2	10	—	—	—	—	—
—	—	—	330	13	1-1/2	10	—	—	—	—	—
—	—	—	330	13	1-1/2	10	—	—	—	—	—
—	—	—	330	13	1-1/2	10	—	—	—	—	—
—	—	—	330	13	1-1/2	10	—	—	—	—	—
—	—	—	330	13	1-1/2	10	—	—	—	—	—
—	—	—	330	13	1-1/2	10	—	—	—	—	—
—	—	—	300	11-3/4	1-1/8	10	—	—	—	—	—
—	—	—	300	11-3/4	1-1/8	10	—	—	—	—	—
—	—	—	300	11-3/4	1-1/8	10	—	—	—	—	—
—	—	—	300	11-3/4	1-1/8	10	—	—	—	—	—
—	—	—	330	13	1-1/2	10	—	—	—	—	—
—	—	—	330	13	1-1/2	10	—	—	—	—	—
—	—	—	330	13	1-1/2	10	—	—	—	—	—
—	—	—	330	13	1-1/2	10	—	—	—	CF127	—
—	—	—	330	13	1-1/2	10	—	—	—	—	—
—	—	—	330	13	1-1/2	10	—	—	—	—	—
—	—	—	330	13	1-1/2	10	—	—	—	CF127	—
—	—	—	330	13	1-1/2	10	—	—	—	—	—
—	—	—	330	13	1-1/2	10	—	—	—	CF127	—
—	—	—	330	13	1-1/2	10	—	—	—	CF127	FWGM16
—	—	—	330	13	1-1/2	10	—	—	—	CF127	FWGM16
—	—	—	330	13	1-1/2	10	—	—	—	—	—
—	—	—	330	13	1-1/2	10	—	—	—	CF127	FWGM16
—	—	—	330	13	1-1/2	10	—	—	—	CF127	FWGM16
—	—	—	330	13	1-1/2	10	—	—	—	—	—
—	—	—	330	13	1-1/2	10	—	—	—	CF127	FWGM16
—	—	—	330	13	1-1/2	10	—	—	—	—	—
—	—	—	330	13	1-1/2	10	—	—	—	—	—
—	—	—	330	13	1-1/2	10	—	—	—	—	—
—	—	—	330	13	1-1/2	10	—	—	—	—	—
—	—	—	330	13	1-1/2	10	—	—	—	—	—
—	—	—	330	13	1-1/2	10	—	—	—	—	—
—	—	—	330	13	1-1/2	10	—	—	—	—	—
—	—	—	330	13	1-1/2	10	—	—	—	—	—
—	—	—	330	13	1-1/2	10	—	—	—	—	—
—	—	—	330	13	1-1/2	10	—	—	—	—	—
—	—	—	330	13	1-1/2	10	—	—	—	—	—
—	—	—	356	14	1-3/4	10	—	—	—	—	—
—	—	—	356	14	1-3/4	10	—	—	—	—	—
—	—	—	356	14	1-3/4	10	—	—	—	—	—
—	—	—	356	14	1-3/4	10	—	—	—	—	—

2020-2021 Product Catalog MEDIUM DUTY TRUCK APPLICATIONS

Liter	cc / in	Cyl	Years	Application Information	Engine Number	Kit
GMC MEDIUM TRUCK CONT.						
<i>W5500</i>						
4.75L			2004	6 Speed	4HE1-TC	GMK1005
HINO TRUCK						
<i>FA1517</i>						
5.3L			2004-03	Diaph Clutch with Cearmic Button	J05C-TD	HNK1000
<i>FB14</i>						
3.9L		4	1991-87	Turbo	W04C-T	KHN04
<i>FB1817</i>						
5.3L			2004-03	Diaph Clutch with Cearmic Button	J05C-TD	HNK1000
<i>FD SERIES</i>						
6.0L		6	1988-80		W06E	KHN01
8.0L			2004-03	Diaph Clutch with Cearmic Button	J05C-TD	HNK1000
<i>FE SERIES</i>						
6.0L		6	1988-84		W06E	KHN01
6.5L		6	1992-89		H06C-T	KHN02
6.7L		6	1988-84		H06C, H07C	KHN02
8.0L		6	1998-89	Diaph Clutch with Cearmic Button	J08C-T	HNK1000
<i>FF SERIES</i>						
6.5L		6	1992-89		H06C-T	KHN02
8.0L		6	1998-89	Diaph Clutch with Cearmic Button	J08C-T	HNK1000
<i>FG SERIES</i>						
6.5L		6	1988-84		H06TH	KHN03
<i>SG SERIES</i>						
6.5L		6	1988-84		H06TH	KHN03
ISUZU MEDIUM DUTY TRUCK						
<i>EVR, W7T</i>						
			1991-90		MLH5G	ISK1004
			1992		MLD6F	ISK1004
			2004			ISK1005
			1989-87	12/87-5/89, Spicer Diaph Clutch with Ceramic Button		ISK1004
			1988-87	To 8/88, Spicer Diaph Clutch with Ceramic Button	MT	ISK1004
<i>FTR, FVR, W7M, T70, T7000</i>						
			1993-88	2/88-5/93, Spicer Diaph Clutch with Ceramic Button	6BD1	ISK1004
			1991-87	From 11/87, Spicer Diaph Clutch with Ceramic Button	6BD1, MT	ISK1004
			1996-93	From 6/93, Spicer Diaph Clutch with Ceramic Button		ISK1004
			1991-90	Spicer Diaph Clutch with Ceramic Button	MLH5G/FS6106A	ISK1004
			2002-97	Spicer Diaph Clutch with Ceramic Button		ISK1004
			2005-04	Spicer Diaph Clutch with Ceramic Button		ISK1005
			1996-90	Spicer Diaph Clutch with Ceramic Button	MLD6F	ISK1004
			1988-84	To 6/88, Spicer Diaph Clutch with Ceramic Button	6BD1T	ISK1004
<i>NPR</i>						
3.9L	3900	4	1990-86		W4	KGM14
3.9L	3900	4	1997-91		W4	KGM20
3.9L	3900	4	2003-99			ISK1001
3.9L	3900	4	2003-99			ISK1006
3.9L	3900	4	1999-95	From 7/95		ISK1000
3.9L	3900	4	2001-98	Heavy Duty Clutch with Silent Design Disc	4HJ1	KGM16
3.9L	3900	4	1990-85	To 5/90	W4	09011
3.9L	3900	4	1997-90	Turbo	4BD1, 4BD2	KGM20
3.9L	3900	4	1994-87	Turbo	4BD1, 4BD2	KGM14

3

MEDIUM DUTY TRUCK APPLICATIONS 2020-2021 Product Catalog

Cover	Disc	Rel Brg	Disc (mm)	Disc (in)	Spline Dia	Splines	Master Cyl	Slave Cyl	Clutch Cable	Clutch Fork	New Flywheel
—	—	—	350	13-3/4	1-1/2	10	—	—	—	—	—
—	—	—	356	14	1-3/4	10	—	—	—	—	—
—	—	—	300	11-13/16	1-1/2	10	—	—	—	—	—
—	—	—	356	14	1-3/4	10	—	—	—	—	—
—	—	—	325	12-13/16	1-1/2	10	—	—	—	—	—
—	—	—	356	14	1-3/4	10	—	—	—	—	—
—	—	—	325	12-13/16	1-1/2	10	—	—	—	—	—
—	—	—	352	13-7/8	1-3/4	10	—	—	—	—	—
—	—	—	352	13-7/8	1-3/4	10	—	—	—	—	—
—	—	—	356	14	1-3/4	10	—	—	—	—	—
—	—	—	352	13-7/8	1-3/4	10	—	—	—	—	—
—	—	—	356	14	1-3/4	10	—	—	—	—	—
—	—	—	381	15	1-3/4	10	—	—	—	—	—
—	—	—	381	15	1-3/4	10	—	—	—	—	—
—	—	—	356	14	1-1/12	10	—	—	—	—	—
—	—	—	356	14	1-1/12	10	—	—	—	—	—
—	—	—	356	14	1-1/12	10	—	—	—	—	—
—	—	—	356	14	1-1/12	10	—	—	—	—	—
—	—	—	356	14	1-1/12	10	—	—	—	—	—
—	—	—	356	14	1-1/12	10	—	—	—	—	—
—	—	—	356	14	1-1/12	10	—	—	—	—	—
—	—	—	356	14	1-1/12	10	—	—	—	—	—
—	—	—	356	14	1-1/12	10	—	—	—	—	—
—	—	—	356	14	1-1/12	10	—	—	—	—	—
—	—	—	356	14	1-1/12	10	—	—	—	—	—
—	—	—	300	11-13/16	1	24	—	—	—	—	—
—	—	—	300	11-13/16	1-1/8	21	—	—	—	—	—
—	—	—	300	11-13/16	1-1/8	21	—	—	—	—	—
—	—	—	300	11-13/16	1-1/8	21	—	—	—	—	—
—	—	—	300	11-13/16	1-1/8	21	—	—	—	—	—
—	—	—	300	11-13/16	1-1/8	21	—	—	—	—	—
—	—	—	273	10-3/4	1	24	—	—	—	—	—
—	—	—	300	11-13/16	1-1/8	21	—	—	—	—	—
—	—	—	300	11-13/16	1	24	—	—	—	—	—

3

2020-2021 Product Catalog MEDIUM DUTY TRUCK APPLICATIONS

Liter	cc / in	Cyl	Years	Application Information	Engine Number	Kit
ISUZU MEDIUM DUTY TRUCK CONT.						
<i>NPR CONT.</i>						
3.9L	3900	4	1987-84	With Ceramic Disc	W4	KIS03
MACK MIDLINER (RENAULT) (RVI)						
<i>MS200, MS250</i>						
5.5L		6	1999-83	Spicer Transmission	MS200	MKM1000S
5.5L		6	1999-83	Spicer Transmission		MKM1001
6.2L		6	1999-83			MKM1002
6.2L		6	1999-83	Eaton Transmi+E341ssion	MS250	MKM1000E
6.2L		6	1999-83	Spicer Transmission		MKM1001
8.8L		6	1999-83			MKM1003
8.8L		6	1999-83	Spicer Transmission	MS250	MKM1001
MITSUBISHI FUSO						
<i>FE</i>						
3.3L		4	1991-87	FE434, FE444, Organic Disc		MFK1002
3.9L		4	1991-87	FE434, FE444, Ceramic Disc		MFK1003
3.9L		4	1995-92	FE439, FE649, Ceramic Disc		MFK1004
3.9L		4	1995-92	FE439, FE649, Organic Disc		MFK1001
3.9L		4	2003-96	FE639, FE649, Ceramic Disc		MFK1004
3.9L		4	2003-96	FE639, FE649, Organic Disc		MFK1001
<i>FG</i>						
3.9L		4	1991-90	FG434, Organic Disc		MFK1005
3.9L		4	1993-92	FG439, Ceramic Disc		MFK1004
3.9L		4	1993-92	FG439, Organic Disc		MFK1001
3.9L		4	2003-98	FG639, Ceramic Disc		MFK1004
3.9L		4	2003-98	FG639, Organic Disc		MFK1001
<i>FH</i>						
5.9L			2002-98	5 & 6 Speed, Coil Spring, Ceramic Disc	6D34-0AT2	MFK1012
5.9L			1995-90	FH100, Ceramic Disc		MFK1007
5.9L			2003-96	FH211, Ceramic Disc		MFK1008
5.9L			1999-88	FH100, Organic Disc		MFK1006
<i>FK</i>						
7.5L			2003-98	5 & 6 Speed, Coil Spring, Ceramic Disc	6D16-2AT3	MFK1013
7.5L			1991-89	FK415, Ceramic Disc		MFK1011
7.5L			1988	FK415, Organic Disc		MFK1010
7.5L			1987-86	FK415, Organic Disc		MFK1009
<i>FM-SP</i>						
7.5L			2003-98	6 & 10 Speed, Coil Spring, Ceramic Disc		MFK1014
NAVISTAR						
<i>392, 406, 450, 461, 501, BC150, BC100, D354, DV550, RD372, V304, V345, V549, VS401, VS478, VS549</i>						
			1996-65	Diaph Clutch		GMK1005
3.9L			1996-87	Diaph Clutch		NVK1000
6.9L			1996-87	Diaph Clutch		NVK1000
7.3L			1996-87	Diaph Clutch		NVK1000
<i>530, DT360, DT466, DT530</i>						
			2002-85			7683-5
			2002-88			7237-10
NISSAN DIESEL TRUCK - UD						
6.9L		6	1987-86	CLA83, CMA83, CPB12	FE6	KNS01
7.4L		6	1987-85	CPB12, CPC12	NE6T	NDK1001
7.4L		6	1987	CPB14, CPC14, CPC15, with RL Plate		NDK1002
7.4L		6	1987	CPC12, Lever Clutch w/o RL Plate	NE6T	NDK1000
<i>1100</i>						
			1991-89	Organic disc	FD35T	NDK1003

MEDIUM DUTY TRUCK APPLICATIONS 2020-2021 Product Catalog

Cover	Disc	Rel Brg	Disc (mm)	Disc (in)	Spline Dia	Splines	Master Cyl	Slave Cyl	Clutch Cable	Clutch Fork	New Flywheel
—	—	—	273	10-3/4	1	24	—	—	—	—	—
—	—	—	330	12-7/8	1-1/2	13	—	—	—	—	—
—	—	—	350	13-3/4	1-1/2	14	—	—	—	—	—
—	—	—	350	13-3/4	1-1/2	14	—	—	—	—	—
—	—	—	350	13-3/4	1-1/2	13	—	—	—	—	—
—	—	—	350	13-3/4	1-1/2	14	—	—	—	—	—
—	—	—	350	13-3/4	1-3/4	14	—	—	—	—	—
—	—	—	350	13-3/4	1-1/2	14	—	—	—	—	—
—	—	—	350	13-3/4	1-1/2	14	—	—	—	—	—
—	—	—	350	13-3/4	1-1/2	14	—	—	—	—	—
—	—	—	350	13-3/4	1-1/2	14	—	—	—	—	—
—	—	—	350	13-3/4	1-1/2	14	—	—	—	—	—
—	—	—	300	11-13/16	1-3/8	14	—	—	—	—	—
—	—	—	300	11-13/16	1-3/8	14	—	—	—	—	—
—	—	—	300	11-13/16	1-3/8	14	—	—	—	—	—
—	—	—	300	11-13/16	1-3/8	14	—	—	—	—	—
—	—	—	300	11-13/16	1-3/8	14	—	—	—	—	—
—	—	—	275	10-3/4	1-5/32	14	—	—	—	—	—
—	—	—	300	11-13/16	1-3/8	14	—	—	—	—	—
—	—	—	300	11-13/16	1-3/8	14	—	—	—	—	—
—	—	—	300	11-13/16	1-3/8	14	—	—	—	—	—
—	—	—	300	11-13/16	1-3/8	14	—	—	—	—	—
—	—	—	325	12-13/16			—	—	—	—	—
—	—	—	300	11-13/16			—	—	—	—	—
—	—	—	300	11-13/16			—	—	—	—	—
—	—	—	300	11-13/16			—	—	—	—	—
—	—	—	350	13-3/4	1-3/8	14	—	—	—	—	—
—	—	—	325	12-13/16	1-3/8	14	—	—	—	—	—
—	—	—	325	12-13/16	1-3/8	14	—	—	—	—	—
—	—	—	325	12-13/16	1-3/8	14	—	—	—	—	—
—	—	—	380	15	1-3/4	14	—	—	—	—	—
—	—	—	350	13-3/4	1-1/2	10	—	—	—	—	—
—	—	—	310	12-1/4	1-1/4	10	—	—	—	—	—
—	—	—	310	12-1/4	1-1/4	10	—	—	—	—	—
—	—	—	310	12-1/4	1-1/4	10	—	—	—	—	—
—	—	—	356	14	1-3/4	10	—	—	—	—	—
—	—	—	356	14	1-3/4	10	—	—	—	—	—
—	—	—	330	13	1-3/16	16	—	—	—	—	—
—	—	—	325	12-13/16	1-3/8	10	—	—	—	—	—
—	—	—	380	14-7/8	1-5/8	10	—	—	—	—	—
—	—	—	381	15	1-3/4	10	—	—	—	—	—
—	—	—	275	10-7/8	1	24	—	—	—	—	—

3

2020-2021 Product Catalog MEDIUM DUTY TRUCK APPLICATIONS

Liter	cc / in	Cyl	Years	Application Information	Engine Number	Kit
NISSAN DIESEL TRUCK - UD CONT.						
<i>1200, 1300, 1400</i>						
			0			—
			0			—
			2004-99	Organic disc	FD46TA	NDK1006
			1994-92	Organic disc	TD42T	NDK1003
			1998-95	Organic disc	TD42T	NDK1005
<i>1800</i>						
			0			—
			0			—
			2004-92	Ceramtallic disc	FE6T, FE6TA	NDK1004
			2004-99	Ceramtallic disc	FD46TA	NDK1007
			2004-92	Organic disc	FE6T, FE6TA	NDK1011
			1991-89	Organic disc	FE6T	NDK1008
<i>2000</i>						
			0			—
			0			—
			2004-92	Ceramtallic disc	FE6T, FE6TE	NDK1004
			2004-92	Organic disc	FE6T, FE6TE	NDK1011
			1991-89	Organic disc	FE6T	NDK1008
<i>2300</i>						
			0			—
			0			—
			2004-89	Ceramtallic disc	FE6T, FE6TE	NDK1004
			2004-89	Organic disc	FE6T, FE6TE	NDK1011
<i>2600</i>						
			0			—
			0			—
			2004-89	Ceramtallic disc	FE6T, FE6TE	NDK1004
			2004-89	Organic disc	FE6T, FE6TE	NDK1011
<i>2800</i>						
			0			—
			0			—
			1994-89	Ceramtallic disc	FE6T, FE6TE	NDK1004
			1994-89	Organic disc	FE6T, FE6TE	NDK1011
<i>3000</i>						
			0			—
			0			—
			2000-92	Ceramtallic disc	FE6T, FE6TE	NDK1004
			2000-92	Organic disc	FE6T, FE6TE	NDK1011
			1994-92	Organic disc	NE6TA	NDK1002
			1991-89	Organic disc	NE6T	NDK1009
<i>3300</i>						
			2000-99	Ceramtallic disc	FE6TA	NDK1004
			1994-89	Organic disc	NE6T, NE6TA	NDK1002
			2000-99	Organic disc	FE6TA	NDK1011
<i>550, 600T</i>						
			1994-89	Organic disc	NE6T, NE6TA	NDK1002
VOLVO TRUCK						
<i>FE</i>						
7.2L	439		1995-93	CAT Engine 3116		VLK1002
7.2L	439		1992-90	CAT Engine 3116		VLK1000

3

MEDIUM DUTY TRUCK APPLICATIONS 2020-2021 Product Catalog

Cover	Disc	Rel Brg	Disc (mm)	Disc (in)	Spline Dia	Splines	Master Cyl	Slave Cyl	Clutch Cable	Clutch Fork	New Flywheel
—	—	—					—	—	—	—	—
—	—	—					—	—	—	—	—
—	—	—	300	11-13/16	1	24	—	—	—	—	—
—	—	—	275	10-7/8	1	24	—	—	—	—	—
—	—	—	300	11-13/16	1	24	—	—	—	—	—
—	—	—					—	—	—	—	—
—	—	—					—	—	—	—	—
—	—	—	350	13-3/4	1-1/2	10	—	—	—	—	—
—	—	—	325	12-13/16	1-3/8	16	—	—	—	—	—
—	—	—	350	13-3/4	1-1/2	10	—	—	—	—	—
—	—	—	325	12-13/16	1-3/8	16	—	—	—	—	—
—	—	—					—	—	—	—	—
—	—	—					—	—	—	—	—
—	—	—	350	13-3/4	1-1/2	10	—	—	—	—	—
—	—	—	350	13-3/4	1-1/2	10	—	—	—	—	—
—	—	—	325	12-13/16	1-3/8	16	—	—	—	—	—
—	—	—					—	—	—	—	—
—	—	—					—	—	—	—	—
—	—	—	350	13-3/4	1-1/2	10	—	—	—	—	—
—	—	—	350	13-3/4	1-1/2	10	—	—	—	—	—
—	—	—					—	—	—	—	—
—	—	—					—	—	—	—	—
—	—	—	350	13-3/4	1-1/2	10	—	—	—	—	—
—	—	—	350	13-3/4	1-1/2	10	—	—	—	—	—
—	—	—					—	—	—	—	—
—	—	—					—	—	—	—	—
—	—	—	350	13-3/4	1-1/2	10	—	—	—	—	—
—	—	—	350	13-3/4	1-1/2	10	—	—	—	—	—
—	—	—					—	—	—	—	—
—	—	—					—	—	—	—	—
—	—	—	350	13-3/4	1-1/2	10	—	—	—	—	—
—	—	—	350	13-3/4	1-1/2	10	—	—	—	—	—
—	—	—	380	14-7/8	1-5/8	10	—	—	—	—	—
—	—	—	350	13-3/4	1-1/2	10	—	—	—	—	—
—	—	—					—	—	—	—	—
—	—	—					—	—	—	—	—
—	—	—	350	13-3/4	1-1/2	10	—	—	—	—	—
—	—	—	380	14-7/8	1-5/8	10	—	—	—	—	—
—	—	—	350	13-3/4	1-1/2	10	—	—	—	—	—
—	—	—					—	—	—	—	—
—	—	—					—	—	—	—	—
—	—	—	356	14	1	10	—	—	—	—	—
—	—	—	356	14	1	10	—	—	—	—	—

3



SECTION 4
CONVERSIONS
METRIC TO INCHES

To Convert

Formula

Cubic Inches to Liters	LITERS times 61.024 equals CUBIC INCHES
Liters to Cubic Inches	CUBIC INCHES divided by 61.024 equals LITERS

LITERS	CC / CI	LITERS	CC / CI	LITERS	CC / CI	LITERS	CC / CI
1.0L	61	1.6L	1588	2.0L	1952	2.3L	2299
1.0L	948	1.6L	1588	2.0L	1955	2.3L	2300
1.0L	995	1.6L	1589	2.0L	1958	2.3L	2302
1.0L	1000	1.6L	1590	2.0L	1967	2.3L	2307
1.0L	1146	1.6L	1595	2.0L	1968	2.3L	2309
1.1L	1100	1.6L	1596	2.0L	1970	2.3L	2316
1.1L	1116	1.6L	1597	2.0L	1971	2.3L	2341
1.1L	1146	1.6L	1599	2.0L	1972	2.4L	145
1.2L	1166	1.6L	1600	2.0L	1974	2.4L	146
1.2L	1189	1.6L	1606	2.0L	1975	2.4L	148
1.2L	1196	1.6L	1639	2.0L	1983	2.4L	150
1.2L	1200	1.7L	104	2.0L	1984	2.4L	2351
1.2L	1237	1.7L	1678	2.0L	1985	2.4L	2366
1.3L	79	1.7L	1700	2.0L	1986	2.4L	2389
1.3L	81	1.7L	1715	2.0L	1989	2.4L	2393
1.3L	1272	1.7L	1721	2.0L	1990	2.4L	2398
1.3L	1275	1.8L	107	2.0L	1991	2.4L	2400
1.3L	1289	1.8L	110	2.0L	1994	2.4L	2435
1.3L	1290	1.8L	112	2.0L	1997	2.4L	2438
1.3L	1295	1.8L	113	2.0L	1998	2.5L	148
1.3L	1300	1.8L	1590	2.0L	2792	2.5L	150
1.3L	1301	1.8L	1597	2.1L	126	2.5L	151
1.3L	1308	1.8L	1751	2.1L	2056	2.5L	152
1.3L	1328	1.8L	1754	2.1L	2100	2.5L	153
1.3L	1335	1.8L	1760	2.1L	2109	2.5L	173
1.3L	1342	1.8L	1762	2.1L	2119	2.5L	262
1.4L	85	1.8L	1770	2.1L	2127	2.5L	2451
1.4L	1393	1.8L	1780	2.2L	132	2.5L	2458
1.4L	1397	1.8L	1781	2.2L	133	2.5L	2459
1.4L	1400	1.8L	1790	2.2L	134	2.5L	2475
1.4L	1410	1.8L	1793	2.2L	135	2.5L	2492
1.4L	1415	1.8L	1795	2.2L	2109	2.5L	2493
1.5L	90	1.8L	1796	2.2L	2144	2.5L	2494
1.5L	92	1.8L	1797	2.2L	2147	2.5L	2497
1.5L	1452	1.8L	1798	2.2L	2155	2.5L	2498
1.5L	1456	1.8L	1800	2.2L	2156	2.5L	2500
1.5L	1457	1.8L	1809	2.2L	2163	2.5L	2508
1.5L	1468	1.8L	1817	2.2L	2164	2.6L	156
1.5L	1471	1.8L	1829	2.2L	2180	2.6L	2555
1.5L	1475	1.8L	1834	2.2L	2184	2.6L	2557
1.5L	1487	1.8L	1836	2.2L	2187	2.6L	2559
1.5L	1488	1.8L	1839	2.2L	2189	2.6L	2563
1.5L	1489	1.8L	1840	2.2L	2195	2.6L	2565
1.5L	1490	1.8L	1845	2.2L	2197	2.6L	2588
1.5L	1491	1.9L	116	2.2L	2200	2.6L	2597
1.5L	1493	1.9L	119	2.2L	2212	2.6L	2599
1.5L	1495	1.9L	1858	2.2L	2226	2.6L	2600
1.5L	1497	1.9L	1872	2.2L	2237	2.6L	2606
1.5L	1500	1.9L	1895	2.3L	138	2.7L	165
1.5L	1508	1.9L	1896	2.3L	140	2.7L	167
1.6L	97	1.9L	1898	2.3L	173	2.7L	294
1.6L	98	1.9L	1900	2.3L	2253	2.7L	2656
1.6L	1565	1.9L	1915	2.3L	2254	2.7L	2671
1.6L	1573	1.9L	1949	2.3L	2259	2.7L	2672
1.6L	1586	2.0L	121	2.3L	2290	2.7L	2673
1.6L	1587	2.0L	122	2.3L	2295		

4

CONVERSIONS

2020-2021 Product Catalog

To Convert	Formula
Cubic Inches to Liters	LITERS times 61.024 equals CUBIC INCHES
Liters to Cubic Inches	CUBIC INCHES divided by 61.024 equals LITERS

LITERS	CC / CI	LITERS	CC / CI	LITERS	CC / CI	LITERS	CC / CI
2.7L	2675	3.4L	207	4.8L	292	7.4L	455
2.7L	2688	3.4L	3378	4.8L	294	7.5L	455
2.7L	2693	3.4L	3400	4.9L	300	7.5L	460
2.7L	2694	3.4L	3431	4.9L	301	7.8L	477
2.7L	2700	3.5L	212	5.0L	302	8.0L	488
2.8L	170	3.5L	3430	5.0L	304	8.0L	490
2.8L	171	3.5L	3453	5.0L	305	8.1L	496
2.8L	173	3.5L	3475	5.0L	307	8.3L	505
2.8L	231	3.5L	3500	5.0L	4950		
2.8L	2753	3.5L	3524	5.2L	316		
2.8L	2754	3.5L	3540	5.2L	318		
2.8L	2771	3.5L	3543	5.3L	326		
2.8L	2788	3.6L	221	5.4L	327		
2.8L	2792	3.6L	223	5.4L	329		
2.8L	2793	3.6L	3562	5.4L	330		
2.8L	2800	3.6L	3590	5.5L	330		
2.8L	2827	3.6L	3596	5.6L	340		
2.8L	2849	3.6L	3606	5.6L	343		
2.9L	177	3.7L	225	5.6L	5576		
2.9L	179	3.7L	226	5.7L	347		
3.0L	181	3.8L	229	5.7L	348		
3.0L	182	3.8L	230	5.7L	350		
3.0L	183	3.8L	231	5.7L	351		
3.0L	2954	3.8L	232	5.8L	351		
3.0L	2959	3.8L	3800	5.8L	352		
3.0L	2960	3.9L	235	5.8L	354		
3.0L	2961	3.9L	240	5.8L	5800		
3.0L	2966	3.9L	2950	5.9L	360		
3.0L	2967	3.9L	3900	5.9L	361		
3.0L	2969	3.9L	3950	6.0L	363		
3.0L	2972	4.0L	242	6.1L	370		
3.0L	2980	4.0L	244	6.2L	379		
3.0L	2983	4.0L	3950	6.3L	383		
3.0L	2985	4.0L	3982	6.4L	389		
3.0L	2988	4.0L	4016	6.4L	390		
3.0L	2997	4.1L	250	6.4L	391		
3.0L	2999	4.2L	255	6.5L	395		
3.0L	3000	4.2L	258	6.5L	396		
3.1L	189	4.2L	4172	6.6L	400		
3.1L	191	4.2L	4196	6.6L	401		
3.1L	3137	4.2L	4200	6.6L	402		
3.2L	194	4.3L	260	6.6L	403		
3.2L	196	4.3L	261	6.6L	406		
3.2L	198	4.3L	262	6.7L	409		
3.2L	3165	4.3L	265	6.8L	413		
3.2L	3179	4.3L	4294	6.8L	415		
3.2L	3200	4.4L	265	6.9L	420		
3.2L	3206	4.4L	267	6.9L	421		
3.3L	185	4.4L	270	7.0L	425		
3.3L	200	4.5L	273	7.0L	427		
3.3L	3210	4.6L	281	7.0L	428		
3.3L	3230	4.6L	283	7.0L	429		
3.3L	3275	4.7L	285	7.2L	439		
3.3L	3294	4.7L	287	7.2L	440		
3.3L	3300	4.7L	289	7.3L	446		
3.4L	204	4.8L	290	7.4L	454		

To Convert

Formula

Millimeters to Inches	MILLIMETERS divided by 25.4 equals INCHES
Inches to Milimeters	INCHES times 25.4 equals MILLIMETERS

DISC (IN)	DISC (MM)	DISC (IN)	DISC (MM)	DISC (IN)	DISC (MM)
6-1/4	159	8-3/4	222	10-3/8	264
6-5/16	160	8-13/16	224	10-1/2	267
6-1/2	165	8-7/8	225	10-3/4	273
6-11/16	170	9	229	10-7/8	276
6-3/4	172	9-1/16	230	11	279
7	178	9-1/8	232	11-1/2	292
7-1/8	181	9-1/4	235	11-3/4	298
7-1/4	184	9-5/16	237	11-13/16	300
7-3/8	187	9-3/8	238	11-7/8	302
7-1/2	190	9-7/16	240	12	305
7-7/8	200	9-1/2	241	12-1/4	311
8	203	9-5/8	244	12-3/4	324
8-1/4	210	9-11/16	246	12-13/16	325
8-5/16	211	9-3/4	248	13	330
8-3/8	213	9-7/8	248	13-7/8	352
8-7/16	214	10	254	14	356
8-1/2	216	10-1/8	257	15	381
8-5/8	219	10-1/4	260		

To Convert

Formula

Millimeters to Inches	MILLIMETERS divided by 25.4 equals INCHES
Inches to Milimeters	INCHES times 25.4 equals MILLIMETERS

DISC (MM)	DISC (IN)	DISC (MM)	DISC (IN)	DISC (MM)	DISC (IN)
159	6-1/4	222	8-3/4	264	10-3/8
160	6-5/16	224	8-13/16	267	10-1/2
165	6-1/2	225	8-7/8	273	10-3/4
170	6-11/16	229	9	276	10-7/8
172	6-3/4	230	9-1/16	279	11
178	7	232	9-1/8	292	11-1/2
181	7-1/8	235	9-1/4	298	11-3/4
184	7-1/4	237	9-5/16	300	11-13/16
187	7-3/8	238	9-3/8	302	11-7/8
190	7-1/2	240	9-7/16	305	12
200	7-7/8	241	9-1/2	311	12-1/4
203	8	244	9-5/8	324	12-3/4
210	8-1/4	246	9-11/16	325	12-13/16
211	8-5/16	248	9-3/4	330	13
213	8-3/8	248	9-7/8	352	13-7/8
214	8-7/16	254	10	356	14
216	8-1/2	257	10-1/8	381	15
219	8-5/8	260	10-1/4		

4



SECTION 5
CLUTCH
INSTALLATION
INSTRUCTIONS

How to get it right the first time...

FITTING INSTRUCTIONS: INSTALLING YOUR NEW DAIKIN CLUTCH.

Failure to observe these instructions when fitting your Daikin Clutch will void any warranty.

1. *Getting it right the first time. It is vital to diagnose the cause of clutch malfunction before clutch replacement, i.e. check hydraulic system - bearing free travel - clutch cable, oil leaks and check for any signs of red dust when old clutch is being removed. Any or all of these problems must be corrected before installing a new clutch.*
2. Ensure clutch supplied is correct for the application. If you're unsure, consult your Daikin Clutch Catalogue or your supplier, as fitting a clutch to the wrong application will void the warranty.
3. Flywheel must be machined as shown below (Fig 2.) or warranty will be void and check spigot bearing or the pilot bush and replace if necessary. Please note pilot bush noises are more apparent when the engine and transmission systems are cold (i.e. in the mornings).
4. Before fitting, check the clutch for any shipping damage. Next clean the gear box main drive shaft splines, then check that clutch disc slides freely on the shaft. Lightly grease the shaft splines with high melting point grease. Always ensure bell housing is degreased and is free of any dust and that fibres from the worn clutch are removed. If the clutch is a large size pull type clutch check the ID of the bearing head for correct spline size before installation. Lack of lubrication/dry splines will cause failure to disengage gears and also cause clutch drag.
5. Check clutch release fork for cracks, check the clutch cable for stretch signs and check the release bearing guide tube for any wear. Always lightly grease the outside diameter of the tube. This will allow smooth sliding of the bearing carrier. Always check bearing on clutch release fork after installing the bearing on it. Move the fork forwards and backwards i.e. in both directions, to ensure bearing is secure and does not fall on any part (clutch fork or bell housing) before refitting gear box.
6. Place the clutch cover pressure plate assembly over the clutch disc, after checking that the disc is the right way around and the hub section of the disc does not fall on the casting of the clutch cover assembly or the flywheel. A suitable clutch aligning tool will ensure correct alignment, assist in ease of installation and avoid spline damage. (Burrs on splines are a major cause of difficult gear disengagement). Ensure pressure plate dowels are aligned to the cover. Tighten bolts in a diagonal pattern and never use air tools to install a clutch cover assembly. Torquing down bolts in an uneven pattern in some instances could cause the lever strut to dislodge itself from the pressure plate casting.
7. When the pressure plate has been torqued down securely to the flywheel, ensure that the diaphragm tips (in the case of a lever type cover assembly, the release lever tips) are in a parallel position (see Fig 3) and do not go over center of the parallel position.
8. Refit gear box, taking care not to bend the clutch disc. Never hang the gear box off the clutch disc or use any force to align gear box shaft.
9. Check all bell housing dowels are in correct position and tighten bell housing bolts. Ensure there is no dirt or foreign material between the mating surfaces of the engine and the bell housing.
10. Perform any clutch adjustments to vehicle manufacturer's specifications and always reset the clutch master cylinder push rod to obtain comfortable pedal release position (clutch taking up as close as possible to the floor prevents clutch shudder and in most cases preferred by vehicle drivers). Keep in mind that the diaphragm tip position has changed with the installation of the new clutch.
11. Always check the clutch cable if you are unable to obtain disengagement when a new clutch is fitted. Start off your checking process by replacing the cable. If it is a hydraulic clutch start by checking the clutch master cylinder and the clutch slave cylinder, ensuring there is no air in the system. This is essential to obtain maximum travel for disengagement.
12. Road test vehicle and never abuse a newly fitted clutch. Allow 750 mi break in and always adjust free travel on your new clutch at 750 mi and 1500 mi. Thereafter, adjust at every 7500mi.

5

WARNING: Do not use DAIKIN clutches in any situation where engine RPM's may exceed manufacturer's specifications - a pressure plate could explode unexpectedly causing serious injury or death to vehicle occupants and bystanders. Clutch cover and bell housing will not protect against exploding pressure plates. Refer to the Application Catalogue for correct fit.

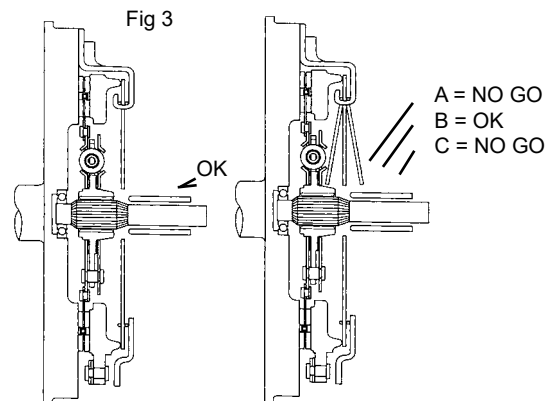
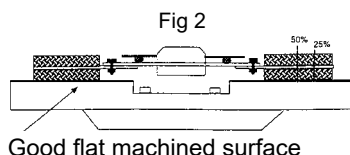
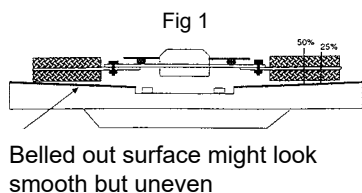

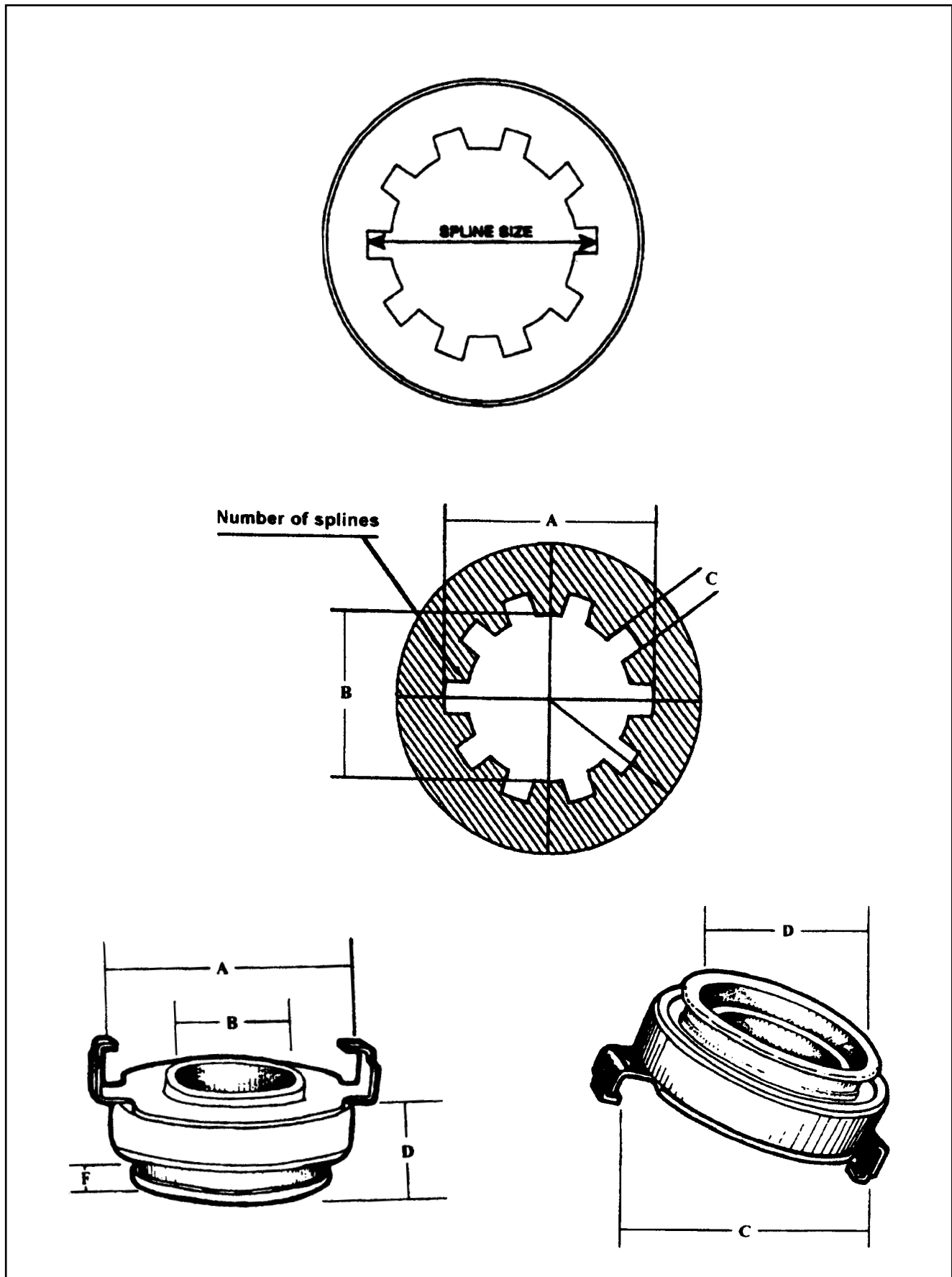

5

NEW TECHNOLOGY DESIGN CLUTCH

STUDY BEFORE DISASSEMBLY

STUDY BEFORE INSTALLATION

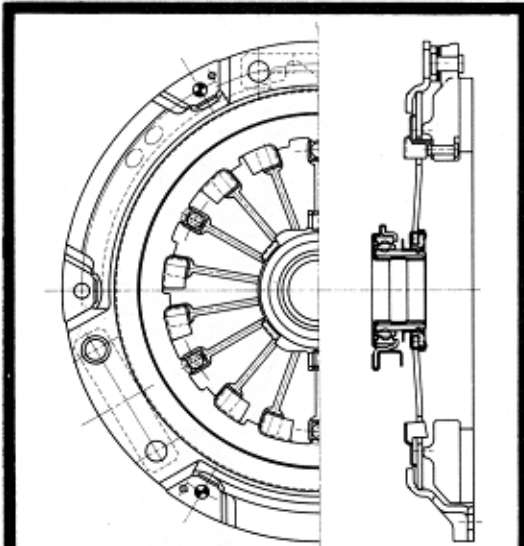

PATENTS PENDING
 One for Pull Clutch
 Four for Release Bearing Mechanism

INSTALLATION AND SNAP-IN PROCESS

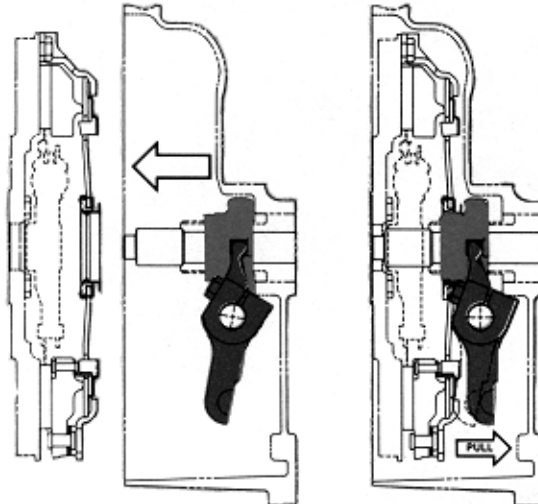

Install Bearing on to clutch fork, install transmission (G/Box) then the release fork must be pulled in the direction reverse to the release firmly. The bearing is then snapped in.

DISASSEMBLY

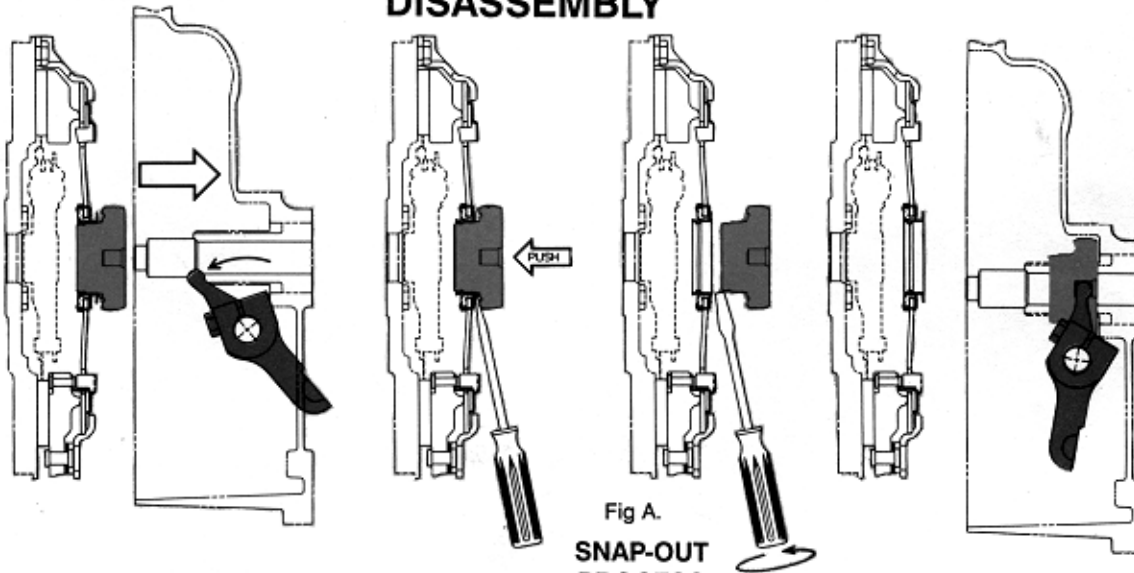

Fig A.
SNAP-OUT PROCESS

Move Bellhousing back approximately 30 to 40mm, insert screwdriver and twist as in figure A. Bearing will then snap out from clip mechanism.

5

BED IN PROCEDURE DRIVER EDUCATION TO BE FOLLOWED

IMPORTANT NOTICE

AFTER INSTALLATION OF THIS CLUTCH PLEASE NOTE DUE TO HIGH PERFORMANCE T5000 FRICTION MATERIAL BEING USED IN YOUR DISC YOU MAY ENCOUNTER SLIGHT CLUTCH SHUDDER AS WITH ANY CERAMETALLIC CLUTCH SYSTEM THERE WILL BE SOME COMPROMISE OF START UP DRIVEABILITY AS COMPARED TO A STOCK CLUTCH (CHATTER ON LIGHT THROTTLE, AT LOW RPM START UPS.)

THESE CHARACTERISTICS ARE GENERALLY ACCEPTABLE IN MODIFIED PERFORMANCE CARS. DRIVERS WHO CHOOSE CERAMETALLIC CLUTCHES MUST BE AWARE OF THIS.

NOTES:

5

**For Exedy Sport & Performance Listings
please refer to our 2020-21 Sports Catalog**

**Stage 1 - Single Plate
Organic**

**Stage 2 - Single Plate
Cerametallic, Thick & Thin**

Stage 3 - Hyper Single Plate

Stage 4 - Hyper Twin Plate

**Stage 5 - Hyper Triple Plate,
Carbon Series**

D-Core Series

Replacement Parts



EXEDY



Friction • Damper • Fluid

TECHNICS

EXEDY FDF



Focus on Basics

EXEDY



EXEDY Globalparts Corporation USA Service Directory

Customer Service

(800) 346-6091
(734) 397-3333

East Region Sales

(770) 910-5237

West Region Sales

(801) 232-4695

California Warehouse

1951 E. 48th Street
Vernon, CA 90058
Phone: (323) 582-3800
Fax: (323) 582-3840

Colorado Warehouse

501 Kalamath Street
Denver, CO 80204
Phone: (303) 825-2000
Fax: (303) 825-0132

South Carolina Warehouse

324 Cameron Circle, Unit 8
Myrtle Beach, SC 29579

TECH SUPPORT — MON.-FRI. 8:30AM-5:00PM EST
(734) 397-6633 • (734) 740-1986

EXEDY GLOBALPARTS MAIN WAREHOUSE & NORTH AMERICAN OPERATIONS

8601 Haggerty Rd. • Van Buren Twp., MI 48111 • (800) 346-6091 • Fax: (734) 397-7300

DISTRIBUTED BY:

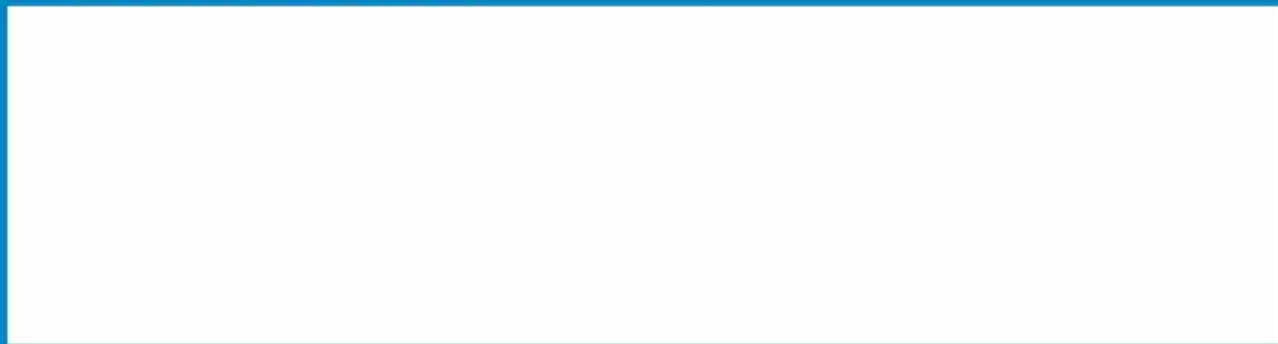

www.exedyusa.com