



EXEDY
RACING CLUTCH

**Performance
Race • Sport**

Clutches & Flywheels

2020-2021



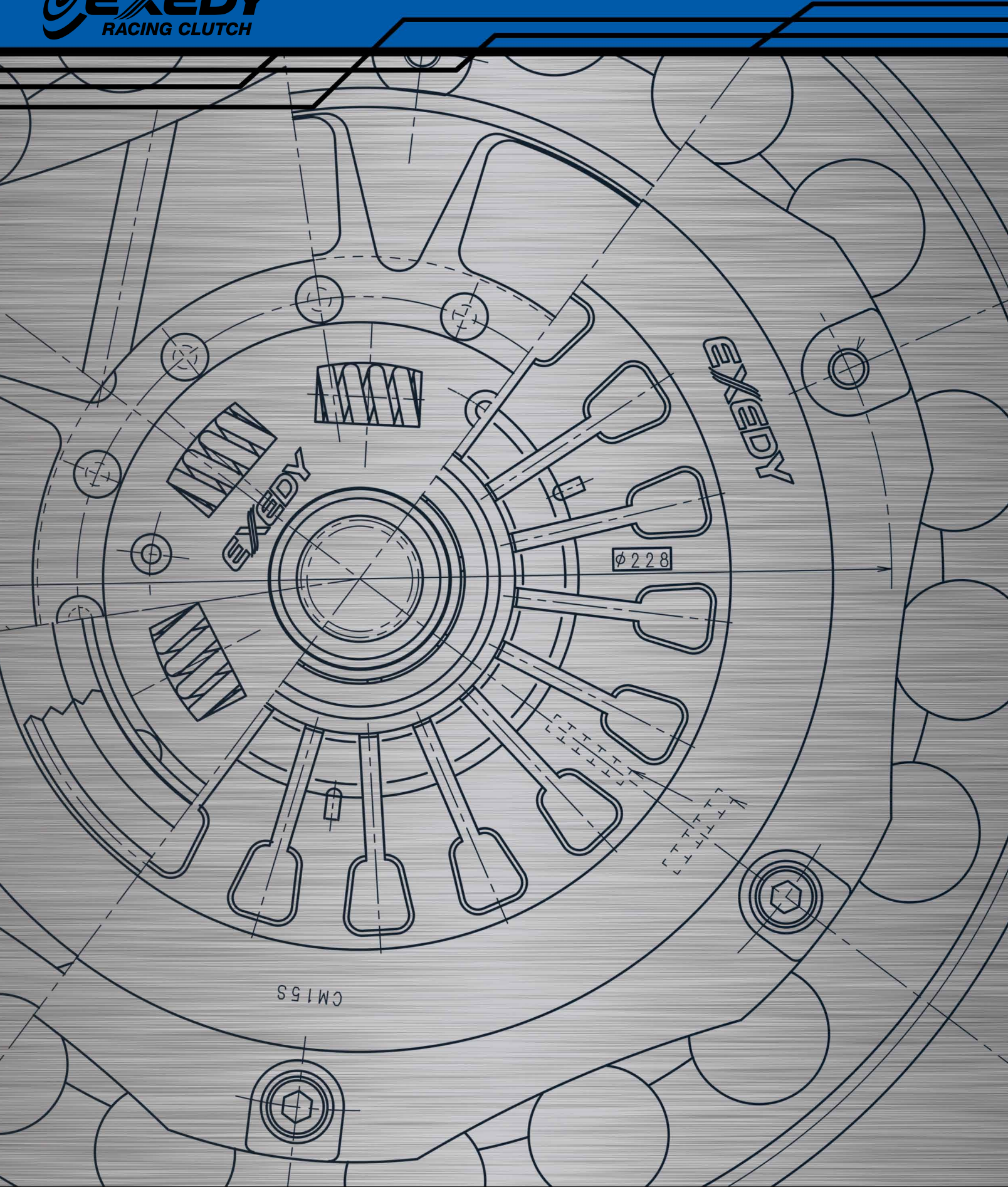

EXEDY has an App on IOS!

With the App you will be able to search and browse EXEDY's massive product line-up of OEM Replacement Clutches, Performance Clutches and Transmission Parts.

This app will help you find the clutch you need for your application as well as answer some frequently asked questions.

App available through your App store.

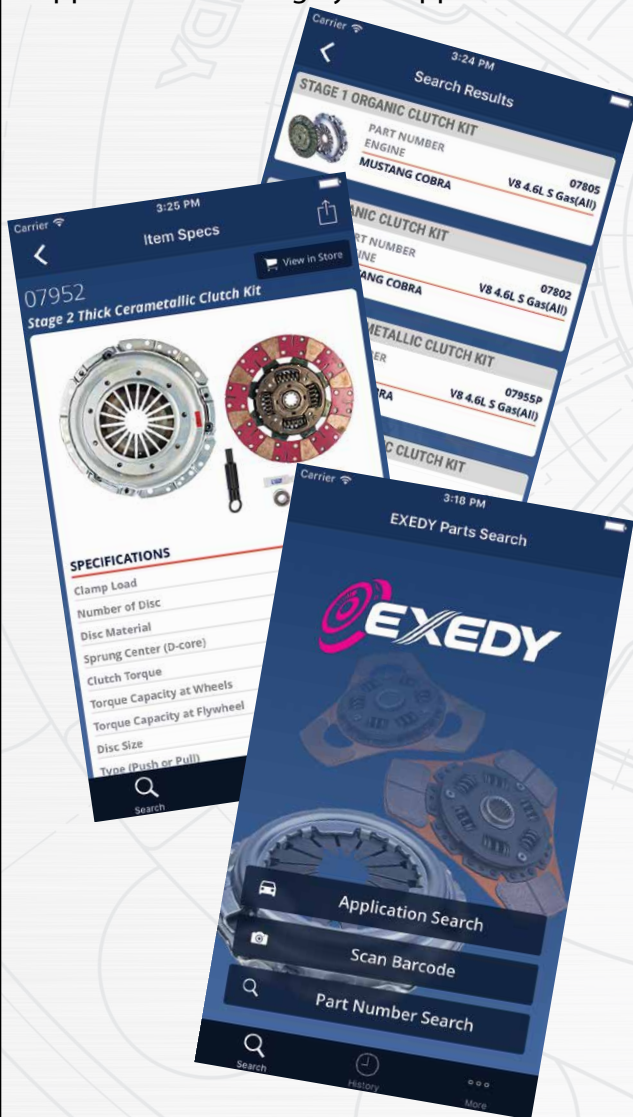

Table of Contents

About EXEDY	5
Technology	5-6
EXEDY Globalparts Corporation	7
Corporate Profile	8
Worldwide Network	9
EXEDY Customer Portal	10
Part Number Legend	11
Terms and Conditions	12-13
Attention - Installation Warning	13
Choosing the Correct Clutch	14-16
Stage 1 - Organic Single Plate Clutch	17
Stage 2 - Cerametallic Single Plate Clutch	18
Flywheels	19
Application Guide Stage 1, 2 and Flywheels.....	20-43
Stage 3 - Hyper Single Plate Clutch	44-45
Stage 4 & 5 - Hyper Multi Plate Clutch	46-47
Hyper Carbon Series Clutch.....	48-49
Hyper Carbon-D Series Clutch	50-51
Application Guide Hyper Series Clutches.....	52-67
Hyper Accessory Kits.....	68-74
Hyper Builder Series	76-77
Hyper Single Repair Parts	78
Hyper Carbon Single Repair Parts	79
Hyper Multi-Plate Repair Parts	80-81
Hyper Builder Series Repair Parts	82
Hyper Carbon Multi-Plate Repair Parts	84-85
Conversions	86-88

A sheet of white lined paper is centered on a dark blue background. The paper has horizontal lines for writing. In the background, there is a faint, light gray technical drawing of a mechanical part, possibly a hub or a rotor. The drawing includes various components like bolts, a central hub, and the 'EXEDY' logo. The paper is slightly offset to the right and bottom.

The Pursuit of Excellence

World's Largest Manufacturer of Sports/Performance/Racing Clutch Products. Your prerequisite to WIN!

About EXEDY

EXEDY Corporation of Japan (formerly known as Daikin Manufacturing Company) is one of the largest independent OEM suppliers. We supply all of the major Japanese vehicle manufacturer's as well as Ford and GM in the US. We are also the leading manufacturer of racing clutches in Japan and supply all six factory vehicle manufacturer's race teams. Unlike our competitors, our clutches are NOT rebuilt OE, or modified stock clutches. All EXEDY racing and performance clutches are engineered, designed and built from the ground up as race clutches, in the shadow of the OEM products. EXEDY's product innovations are patented worldwide and developed in house using state of the art design, inspection and testing equipment. Before any design goes into production it goes through rigorous tests that simulate severe driving conditions, which ensure perfect performance in your vehicle. Additionally, no part will leave the EXEDY factory without a robotic and visual inspection, which guarantees quality you can stand behind.

Design

In addition to accumulated know-how as a clutch specialist, the latest CAD equipment has been introduced. By utilizing CATIA (3D Design) and FEA (Finite Element Analysis) engineering, the most appropriate designs

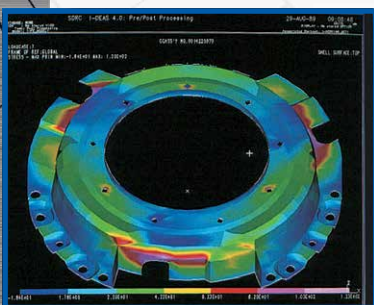

and configurations are tailored to meet each customer's individual requirements. Diaphragm springs are a key component of the clutch assembly, they are designed and made by EXEDY for ultimate performance.

Attestation

We have developed a quality management system to continue offering high quality products and services. In August, 2004 we were certified by the International Automotive Task Force (IATF) with the ISO/TS16949 for our quality standards.

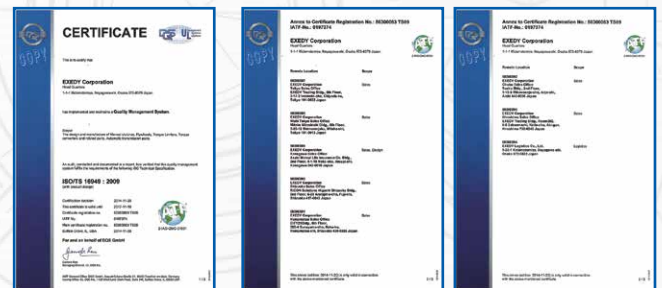

Inspection

EXEDY Multi Plate Clutches are assembled by hand with the finished products being individually assessed for clamp load and release characteristics ensuring the highest quality at all times.

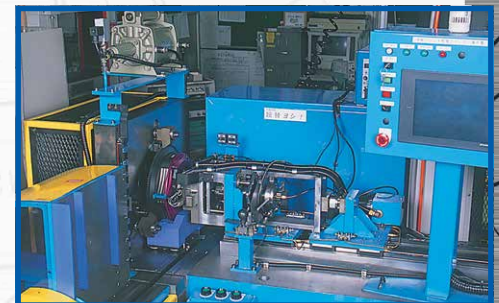

Vehicle Test

At the EXEDY test track, various driving conditions, from normal to severe, are evaluated with information being fed back to the clutch design department. In the actual vehicle, clutch systems are tuned to attain the best clutch performance for the given circumstances.



Expert Check

Clutches developed for mass production have been tested in the field before being introduced into the market place. Experts in each category perform a thorough evaluation of performance clutches which ensures the products will be fit for sale after they pass these given tests.



Bench Test

Various benches have been developed by EXEDY. Tests far too dangerous to be conducted in a vehicle are reproduced on these test benches with the reliability of products being evaluated.



Burst Tester

Evaluation of rotational intensity at extreme high-speed tester.

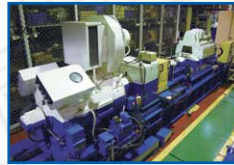

High Speed Full Sized Tester

Evaluation of friction characteristic and durability of clutch disc.



Release Durability Tester

Evaluation of the intensity and fatigue of a diaphragm spring.



Torsional Durability Tester

Evaluation of the durability of clutch disc damper.



Low Inertia and High Torque Transient Dynamometer

Evaluation can be simulated to test: Damper attenuation rate. Rattling noise when the engine is idling. Performance when starting up from a stop. Acceleration shock. Cranking evaluation at engine start-up. Low temperature ATF tests at -30° C.



EXEDY Globalparts Corporation USA

USA, Canada, Central & South America Aftermarket Division

Warehouse Location

Van Buren Twp., Michigan

10 minutes from
Detroit Metropolitan Airport

Warehouse: 120K sqf

Land: 470K sqf

Employees: 60

Complete Aftermarket testing facility, which includes balancer, clamp load tester and hardness tester, hydraulic car lift.

In addition:

OEM Sales

OEM Engineering, Designing and CAE Analysis

OEM Testing and Inspection

Aftermarket Sales and Marketing



Product Lines:

Sports/Performance: Clutch Kits, Flywheels, Hyper Accessory Kits, Hyper Builders Series and Repair Parts

OEM Replacement: Clutch Kits, Clutch Covers, Clutch Discs, Hydraulic Systems and Flywheels

Dynax Wet Friction to Leading Transmission WDs

Corporate Profile

- 1950 Incorporated as DAIKIN Manufacturing Co., Ltd.
- 1973 Established DYNAX Corporation in Hokkaido.
- 1975 Ueno Division Started in Mie.
- 1977 Established DAIKIN Clutch U.S.A., Inc.(present EGP)
- 1981 Kawagoe plant started in Saitama.
- 1995 Changed Corporate name from "Daikin Mfg. Co., Ltd." to "EXEDY Corporation"
- 1997 Listed on 1st Section of Tokyo Stock Exchange.
- 1999 **QS-9000 & ISO9001** Certified in March
- 2000 ISO14001 Certified in June
- 2001 Strategic Alliance with Aisin Seiki Co., Ltd.
- 2004 **ISO/TS16949** Certified in June
- 2012 New headquarter building is complete



Expectation of the new head building

Established July 1950

Net Sales
(For the 2016 Fiscal Year)
Exchange Rate: \$1= ¥110.30

¥266 Billion \$2.41 Billion
(EXEDY Group)

¥119 Billion \$1.07 Billion
(EXEDY Corp.)

Number of Employees
(As of March 31, 2017)
*Includes an average taken for temporary employees

18,040 (EXEDY Group)

3,894 (EXEDY Corp.)

Annual Sales Growth

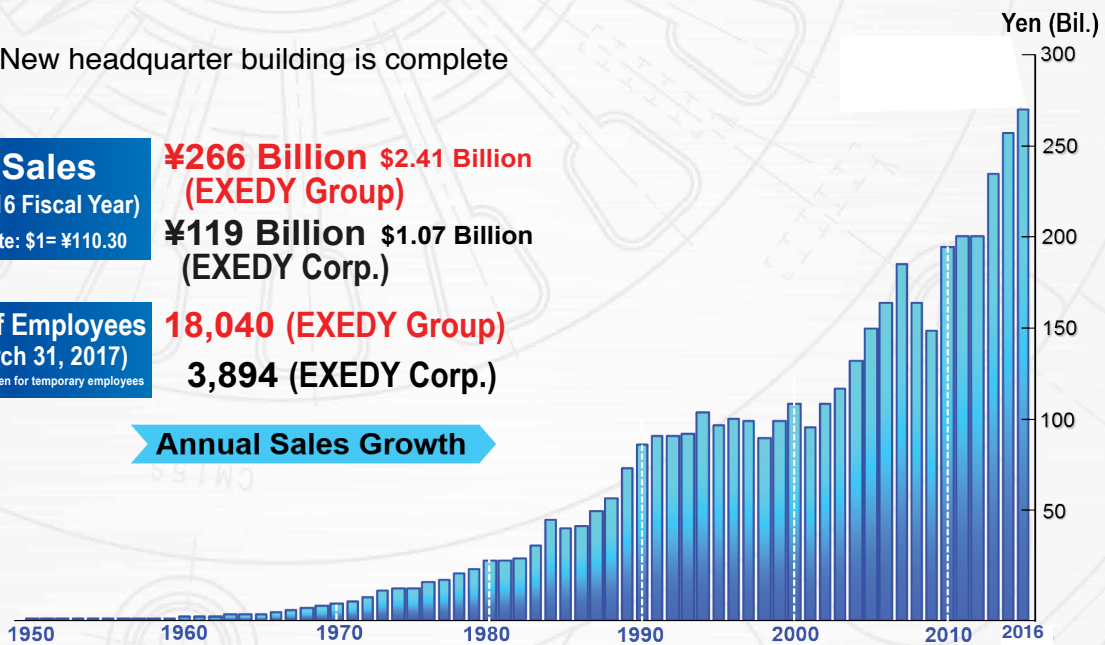

Worldwide Network

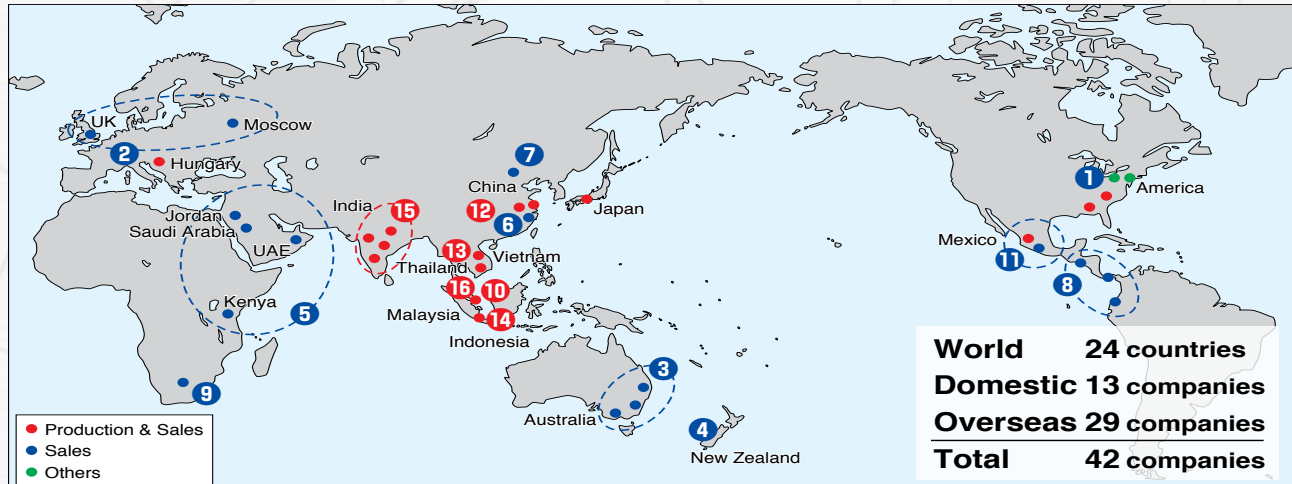

Aftermarket Group

① EXEDY Globalparts Corporation Michigan, U.S.A.



8601 Haggerty Road S.,
Belleville, MI 48111, U.S.A.
TEL:1-734-397-3333
FAX:1-734-397-7300

② EXEDY Clutch Europe Ltd. Cheshire, U.K.



Unit2, Rokeby Court,
Manor Park,
Runcorn, Cheshire,
WA7 1RW, U.K.
TEL:44-1928-571850
FAX:44-1928-571852

③ EXEDY Australia Pty.Ltd. Melbourne, Australia



21 Fiveways Boulevard,
Keaysborough,
Victoria 3173, AUSTRALIA.
TEL:61-3-9701-5556
FAX:61-3-9701-5684

④ EXEDY New Zealand Ltd. (Auckland, New Zealand)



151 Wairau Road Glenfield
Auckland,
NEW ZEALAND
TEL:64-9-444-0901
FAX:64-9-444-0903

⑤ EXEDY Middle East Fzco (Dubai, U.A.E.)



P.O.BOX 18199, Warehouse
No. ZE5 & ZE6 Jebel Ali Free
Zone, Jebel Ali Dubai,
U.A.E.
TEL:971-4-883-2244
FAX:971-4-883-2500

⑥ EXEDY Guangzhou Co., Ltd. (Guangzhou, China)

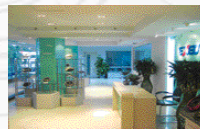

No.406 E-Area, Longfu Car
Accessories Centre, Hengfu
Road, Guangzhou, CHINA
TEL:86-20-83489166
FAX:86-20-83489370

⑦ EXEDY Beijing Co., Ltd. (Beijing, China)



Parts wholesale hall
No.3063-3065,
Wufangtianya Auto
Accessories&Parts Market ,
Chaoyang district, Beijing,
CHINA
TEL:86-10-67297987

⑧ EXEDY Latin America S.A.



P.H. World Trade Center,
Piso 3, Oficina 303
Marbella, Panama City,
Republic of Panama
TEL:507-395-7122/7123
FAX:507-395-7124

⑨ EXEDY SOUTH AFRICA (PTY) LTD



49 Loper Avenue, Aeroport,
Kempton Park, South Africa

⑩ EXEDY SINGAPORE PTE. LTD.



37 Ubi Crescent, Singapore
408586
TEL:65-6749-1395
FAX:65-6742-6936

⑪ EXEDY Mexico Aftermarket Sales, S.A. de C.V.



Via Adolfo Lopez Mateos 9,
Col. Lomas Verdes,
Naucalpan, Edo. De
Mexico, 53120,
Mexico
TEL:52-55-5572-5127

⑫ EXEDY Chongqing Co., Ltd. (Chongqing, China)



No.4 Longjing Road, North
New Economic
Development Zone,
Chongqing, 401142, CHINA
TEL:86-23-62924439
FAX:86-23-62900348

⑬ EXEDY (Thailand) Co.,Ltd. (Chonburi, Thailand)



700/316 Moo 6, Bangna-
Trad Road, Tumbon Don
Hua Roh, Amphur Muang,
Chonburi 20000,
THAILAND.
TEL:66-38-214-423
FAX:66-38-214-422

⑭ P.T.EXEDY Manufacturing Indonesia (Karawang, Indonesia)



Jl. Permata V Lot EE 3
Kawasan Industri KIIC
Karawang 41361 Jawa
Barat, Indonesia
TEL:62-21-89114666
FAX:62-21-89114568

⑮ EXEDY India Ltd. (Greater Noida, India)



Plot No.L-4, M.I.D.C.
Industrial Area,
Chikalthana, Aurangabad
431 210, Maharashtra, not
M.H.INDIA
TEL:91-240-2484014
FAX:91-240-2484403

⑯ EXEDY India Ltd. (Aurangabad, India)



Plot No.9, Udyog Kendra
Industrial Area, Greater
Noida, 201 304, U.P., INDIA
TEL:91-750-3131000
FAX:91-120-2397086

⑰ EXEDY (Malaysia) Sdn.Bhd. (Negeri Sembilan, Malaysia)



PT 16748, Jalan Permata
1/5, Arab-Malaysian
Industrial Park 71800 Nilai,
Negeri Sembilan,
MALAYSIA
TEL:60-6-7992988
FAX:60-6-7996388

EXEDY Customer Portal

Customers can place PO's anytime, Check Stock & Track Orders - 24 hours, 365 days, No Human Error, No Retyping from Fax, No phone calls for inventory inquiry.

ADVANTAGES TO USING THE PORTAL...

Orders

Create New Order - Upload Excel/CSV/TSV files.
Manage Orders - View Open Orders and Completed Orders.

Inventory

Item Inquiry - Check Availability of Product.

Pricing

View Price List - Check Current Pricing.
Download Price List - Available in Excel/CSV/PDF formats.

Statement

View Statement - View Open Invoices.
Download Statement - Available in Excel/CSV/PDF formats.

Admin

User Maintenance - Setup Users, Change Passwords.
Shipping Settings - Setup Shipping Address and Ship Method.
File Upload Settings - Upload Orders from Any Spreadsheet Program.

Help

Help & Guides - Information to Help You to use the Portal successfully.
Contact Us - Give Us Your Comments, Suggestions and Inquiries.

Points & Rewards

Get points by Web Order & Exchange your point to Rewards or Discounts.

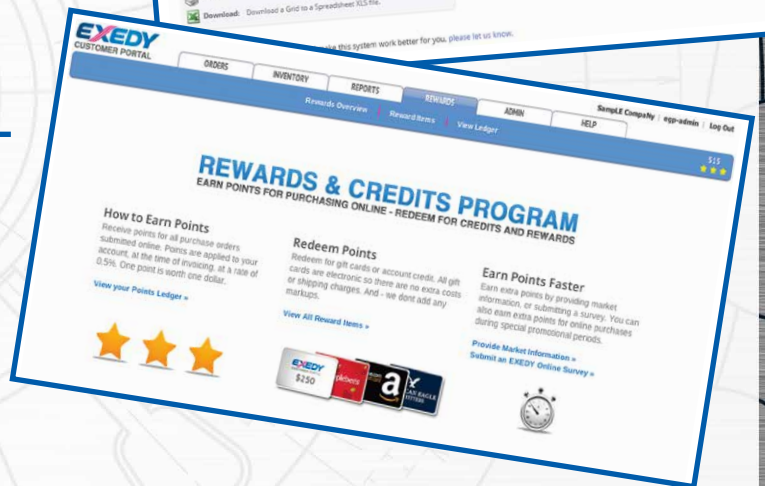

Sign-up for the portal by calling Customer Service at 1-800-346-6091 or emailing portal@exedyusa.com

Part Number Legend

LEGEND													
MT Sports Product	1	2	3	4	5	6	7	8	9	10	11	12	Note
	Maker		Type	EXD/EGP Number Rule									
Cover (EGP#)	H	C		5	0	1							EGP Cover design
Disc (EGP#)	H	D		5	0	1	D						EGP Disc design
Flywheel-Sport (EGP#)	M		F	5	0	1							Flywheel EGP design
Flywheel-Sport (EXD#)	M		F	0	4								Flywheel EXD design
Kit-Sport Organic	0	4		8	0	0							Organic
Kit-Sport Thin Ceramic	0	4		9	0	0							Thin Ceramic
Kit-Sport Thick Ceramic	0	4		9	5	0							Thick Ceramic
Kit Suffixs-Sport							H	D					Heavy Duty
Kit Suffixs-Sport							X	H	D				Extreme Heavy Duty
Kit Suffixs-Sport							F	W	X	H	D		Flywheel included, Extreme Heavy Duty
Kit Suffixs-Sport							F	W					Flywheel included
Kit Suffixs-Sport							F	W	H	D			Heavy Duty w/ Flywheel
Kit Suffixs-Sport							L	B					Less Bearing
Kit Suffixs-Sport							C	S	C				Includes CSC
Kit Suffixs-Sport							P						Puck Type Disc
Kit Suffixs-Sport							P	C	S	C			Puck Type Disc, Includes CSC
Kit Suffixs-Sport							C	B					Cushion Button
Kit Suffixs-Sport							P	4					4 Puck Disc
Kit Suffixs-Sport							A						Bearing Difference
Kit Suffixs-Sport							B						Bearing Difference
Kit Suffixs-Sport							C						Bearing Difference
Accessory Kit	H	C	A	K	1	0	0						Bearing and Pilot Bearing Kit

* Kit Number rules as above applies only suffix changes as necessary
EGP number meaning 800-Organic, 900-Thin Ceramic, 950-Thick Ceramic

Meaning of Kit Suffixs	
HD-Heavy Duty	P-Puck Type Disc
FW-Flywheel included	P4-4 Puck Disc
FWHD-Heavy Duty with Flywheel	A,B,C-Bearing Difference
LB-Less Bearing	XHD-Extreme Heavy Duty
CSC-Includes CSC	FWXHD-Flywheel included, Extreme Heavy Duty
CB-Cushion Button	PCSC-Puck Type Disc, Includes CSC

Legend for Sport Kit

First Number Characters
04-General Motors
05-Mitsubishi
06-Nissan
07-Ford
08-Acura/Honda
10-Mazda
15-Subaru
16-Toyota
17-Volkswagen

Legend for Maker

AU-Audi
BM-BMW
CR-Chrysler
DW-Daihatsu/Daewoo
FM-Ford
GM-General Motors
HC-Acura/Honda
IS-Isuzu
KI-Kia
MB-Mitsubishi
MF-Mitsubishi Fuso
ZC-Mazda
ND-Nissan Diesel
NS-Nissan
OP-Opel
PG-Peugeot
RN-Renault
TY-Toyota
VW-Volkswagen

Legend for Flywheel Sport

HF-Acura/Honda
EF-Ford
GF-GM
ZF-Mazda
MB-Mitsubishi
FF-Subaru
NF-Nissan
TY-Toyota



SFI CERTIFICATION

SFI Foundation Inc. sets special specifications in automotive parts to protect both the driver and spectator. Many racing organizations and tracks now require SFI specifications for different classes and parts used. In general, as cars produce more power and go faster, these specifications become more and more strict. To ensure our customers can race without risk of disqualification EXEDY has tested and certified many of our clutch kits and flywheels such as Stages 1, 2, 3, 4, 5, Carbon Series and the Lightweight Flywheels.

Terms & Conditions

1. All orders accepted by, and goods/products supplied by, EXEDY GLOBALPARTS CORPORATION, hereafter referred to as the Company, are subject to the following Terms and Conditions of Sale. Any exceptions and/or variations must be specifically agreed to in writing by both parties on sports and performance clutch products, warranties offered by the company on standard clutch products, do not apply to sports and performance clutch products.
2. Manufacturers' Names, Part Numbers, Symbols or any other references appearing in the Company's listing and/or on the Company Packaging, are used for reference purposes only and in no way indicate the goods/products are made by, for, and/or guaranteed by such manufacturers.
3. All data, applications and/or interchanges, contained in the Company's listing have been compiled as carefully as possible from reliable and official sources of information available at the time of printing and appears as a general guide only. The information contained herein is correct to the best of the Company's knowledge and belief. However, the Company cannot, and will not, assume any responsibility for possible errors contained in this publication.
4. All goods/products supplied by the Company are warranted against faulty material and/or workmanship but will not cover maltreatment and damage caused by collision, incorrect fitting or normal wear and tear sustained and which is common in a sports clutch application.

Due to the intended use and nature of these goods/products, they are warranted as follows:

Stage 1, Stage 2 and Flywheels - 60 days from date of purchase

Stage 3, Stage 4 and Stage 5 - No Warranty available

Individual components - No Warranty available

5. When the Company's clutch cover, clutch discs, or bearings are repackaged with another manufacturer's parts all warranties are void.
6. Claims will be rejected where clutch kits and/or clutch components have been fitted to incorrect or unlisted applications.
7. Flywheel must be resurfaced/machined to manufacturers specifications before new clutch kit is fitted otherwise warranty will be void.
8. Correct Selection of Products is the Responsibility of the Purchaser.
9. Any goods/products deemed by the Distributor to be faulty must contact our **Technical Support Department** at **800-346-6091** or by email: **TechSupport@exedyusa.com** to obtain an **Inspection Request Form**. A completed Inspection Request Form shall be returned for review, if approved a RGA number will be issued. The goods/products being returned must be sent to the Company **freight prepaid**.
10. No Claim Credit will be issued until the said goods/products have been tested and deemed faulty by the Company.

11. The Company will not pay any claim for goods/products repaired by the Customer and/or claims sight unseen.
12. The Company will not be liable for any labor charges or other expenses incurred nor shall it be liable for any damages or injury to persons or property resulting from misuse or improper installation.
13. It is the responsibility of the Company's Distributor to advise their customer on all aspects of this warranty and/or warranty procedures on any claim.
14. In the event the original purchaser of the clutch needs an urgent replacement kit, the purchaser must buy a new clutch kit from the original distributor. The Company will credit the price of this clutch if the said part sent in for a warranty claim is found to be faulty. A credit will be issued for the value at distributors pricing. Under no circumstance is the distributor without written authorization from the Company to issue a credit to the said purchaser of a faulty clutch.
15. All special ordered goods/products will not be accepted back for return.
16. The Company reserves the right to update or amend these Terms and Conditions at any time without prior notice.

COPYRIGHT/TRADEMARK INFRINGEMENT

1. "EXEDY" and/or its Logos are Registered Trademarks with the United States Patent & Trademark Office, (Registration No. 76482354, WIPO No. 1046491).
2. Trademark infringement is a serious violation of Federal law, subject to severe civil penalties; including, without limitation, injunctive relief, destruction of the infringing products, recovery of the infringer's profits and any actual damages caused by the infringement.
3. Distributor is not allowed to use EXEDY" and/or its Logos, without expressed written consent.

ATTENTION - Installation Warning

Please read before installation and advise driver of vehicle

All Sports & Performance Clutches & Flywheels

When installing a sports/performance clutch in certain vehicles, there can be an increase in transferred harmonic noises from the engine to the gearbox. This may also cause gearbox rattle. These transmitted noises in no way affect the performance of the clutch or the vehicle, and is accepted in the performance industry, where engine and/or clutch modifications have been carried out.

For example:

Replacing an OEM clutch assembly, dual mass flywheel, flex type flywheel, EXEDY silent design or a long travel clutch disc with a high torque center EXEDY sports/performance clutch disc can be the cause of some additional transmitted noise and/or harmonics.

Choosing the Correct EXEDY Sports Clutch

1. What vehicle does the customer have? You will want to know the following.

- a. Manufactures exact model and model year.
- b. Engine size and engine code.
- c. If they have altered the vehicle by doing a engine swap or a transmission swap.
- d. If they have updated or back dated any of the engine and/or transmission components.
- e. Good to know information if at all possible
 1. Input shaft size (measure the outer most diameter of the input shaft spline)
 2. Disc size outer diameter
 3. Vehicle chassis code

2. How much power does the vehicle make? Always ask the customer for torque output at the wheels. Horsepower is a very subjective figure so try to avoid using this figure.

- a. If your customer is unsure about their torque output you will need to find out what modifications they have done to the vehicle. Knowing the vehicles base line torque output and basic research on how much additional power each component has added you can figure out the estimated torque output.
- b. Since your estimated torque output will generally be a flywheel torque figure you will want to remove 20% from your estimated torque output to come up with your estimated wheel torque figure.
- c. If the customer has not done any modifications there is no need for a sports/ racing clutch. Sport/racing clutches are intended to handle a increase in torque above and beyond the capacity of the OEM clutch. Sports/racing clutches are not going to last longer than that of a OEM clutch even if the vehicle is stock as that is not the purpose of a sports/racing clutch.

3. What type of driving is the customer going to be doing?

- a. Street driving
- b. Street / Strip / Weekend racer
- c. Dedicated race car

Choosing the Correct EXEDY Sports Clutch

4. Now that we know the vehicle model, torque output and type of driving the vehicle is being used for we can give the customer a good recommendation on clutch type (stage).

- a. EXEDY Stage 1 clutch is great for the customer looking for a very smooth engaging clutch that is going to drive similar to the OEM unit but capable to handle moderate levels of modifications. This is a great option for the "street driver".
- b. EXEDY Stage 2, 3, 4 Cerametallic disc with sprung hub center section is a great choice for the "street / strip / weekend racer" with applications to handle moderate to aggressive levels of modifications. These units offer a very consistent operation whether being raced or daily driven. The sprung hub center offers ease of engagement and absorbs many of the driveline vibrations at idle and during acceleration/ deceleration.
- c. EXEDY Stage 4, 5 Cerametallic disc with solid hub center section is a great choice for the "dedicated race car" or very highly modified "street / strip / weekend racer" who doesn't not mind sacrificing drivability for performance. This type of clutch will offer a very consistent operation however chatter and driveline vibrations will be experienced due to the solid hub center section.
- d. EXEDY Stage 3, 4 Carbon** disc with sprung hub center section is a great choice for the "dedicated race car" who wants a very smooth engaging clutch with little to no driveline vibrations. The carbon disc is a very lightweight resulting in extremely quick shifts.
- e. EXEDY Stage 3, 4, 5 Carbon** disc with solid hub center section is a great choice for the "dedicated race car" who wants a very smooth engaging clutch that is very lightweight for extremely quick shifts.

***Carbon clutches are not recommended for street use due to the inconsistent friction coefficient from hot to cold. Carbon clutches require a warm up procedure before being driven aggressively. Due to this nature we only recommend carbon clutches for race only applications or to customers who completely understand the characteristics of a carbon clutch. A very big misconception of a carbon clutch is that the vehicle is warm so isn't the clutch? These units work excellent on dedicated race cars due to the driver being able to do the warm up procedure prior to the start of the race and every time driver upshifts or downshifts at higher RPM he is continuing to add heat to the clutch disc. In a street car you often stop at lights, drive in a specific gear, or shift at a lower RPM not allowing adequate heat to be given to the clutch disc. Without heat in a carbon clutch the friction coefficient is significantly lower than when heated. It is at these points in a street car that the customer may decide to put the pedal to the metal causing the clutch to slip and wear out prematurely due to inadequate heat being in the clutch disc.*

Choosing the Correct EXEDY Sports Clutch

5. Lightweight flywheels for the Stage 1, 2 clutch kits are great options to;

- a. Improve throttle response.
- b. Allow the engine to rev more quickly.
- c. Allow the clutch to operate cooler.
- d. Burst tested and SFI approved. Rated to 10,000+RPM.
- e. Remove the OEM dual mass flywheels.

All EXEDY lightweight flywheels are made from a one piece forged chromoly steel which utilize a nitrate hardening process, unique cooling ducts and distribute the weight evenly to allow for better drivability on the street.

6. How to set-up and what to expect from an EXEDY sport/racing product.

- a. Break in period should be that of 500 miles of city type driving, double the break in period for highway driving. No aggressive driving. No hole shots or drag launches. Gear changes should be made at 4,000 RPM or less. No speed shifting.
- b. Installing a sports/racing clutch to suit various vehicles can transfer harmonic noises from the engine to the gearbox. This is also called gearbox rattle. This can occur at idle and during acceleration/deceleration.
- c. Clutch engagement can be compromised by installing a sports/racing clutch. This is due to the heavier torsional dampening springs and/or the solid hub center on the clutch disc. Another factor is due to reduction in cushion plate thickness within an organic clutch disc and/or no cushion plate on the cerametallic and carbon clutch discs. The best way to remedy this situation is a take off at a slightly higher RPM and/or let the clutch out a bit quicker.
- d. Since most of the Stage 4 and 5 multi-plate clutch kits have a free floating pressure plate and intermediate plate there will be a metal on metal noise when the clutch is depressed. This is common on most multi-plate clutches and is acceptable within the racing industry.

Stage 1 - Organic Friction Disc

Ultra Fiber Disc

This advanced facing material provides the high heat resistance essential for motorsports. It was developed by reviewing both the copper wire ratio and the composition of the high strength fiber. The Ultra Fiber Disc maintains the superior half-engagement feeling specific to the Organic material. With improved high heat resistance, it provides the functionality essential for street performance and mild racing applications.

Organic Disc

Newly developed asbestos free friction facing is used, which has high heat resistance and high burst strength characteristics. No steel back is required which can cause high RPM "lock-out" and/or synchro damage. Superior in shift operations and half-engagement feel, this clutch disc is recommended for any sports/performance use.

Clutch Cover

These clutch covers are designed to achieve a clamping load that is approx. 40% higher than the genuine part allowing a higher torque transmitting capacity. Ductile material is used for all pressure plates and, high burst strength can be achieved in all temperature ranges with this material. EXEDY covers are finished by an electroplating process that is environmentally friendly.

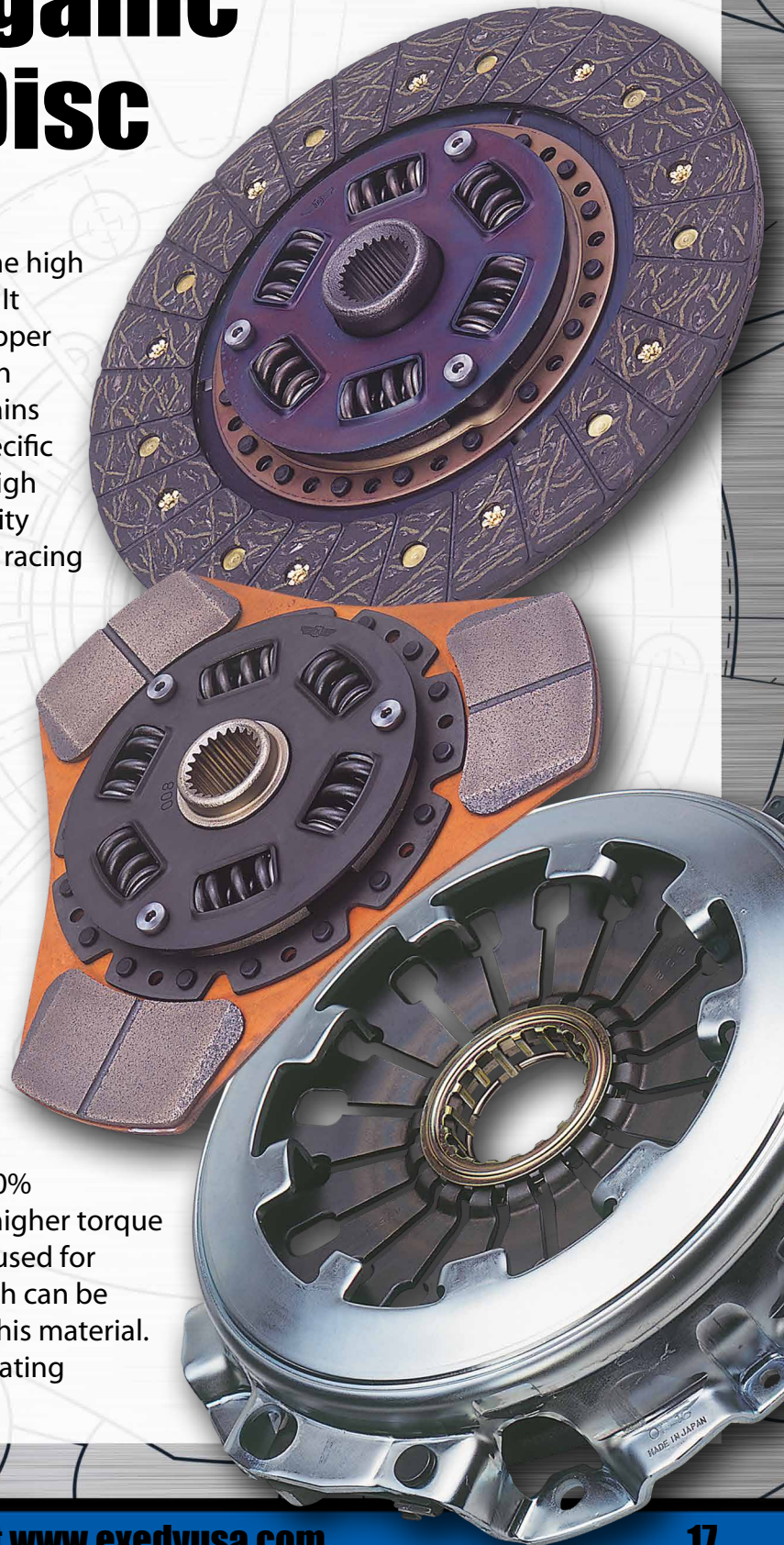

Stage 2 - Cerametallic Friction Disc

EXEDY cerametallic clutches are designed to handle the abuse of high power modified engines. Our cerametallic friction material can handle much more abuse than stock type disc assemblies without slipping and fading.

All EXEDY Stage 2 cerametallic clutch discs have sprung center dampers to reduce the impact and shock loads transmitted through the drivetrain. We offer two types of cerametallic discs, "thick" and "thin."

Thick Disc

The "thick" discs have better heat capacity and therefore better durability in demanding applications. Even with the "thick" disc, our three and four puck designs typically have less inertia than a stock disc and work well for street, rally and track use.

Thin Disc

The "thin" discs offer greatly reduced inertia to improve shift effort, allow for quicker shifting, and improve synchro durability. These discs are approximately 1/2 the thickness of a stock disc and are recommended for circuit track use only.

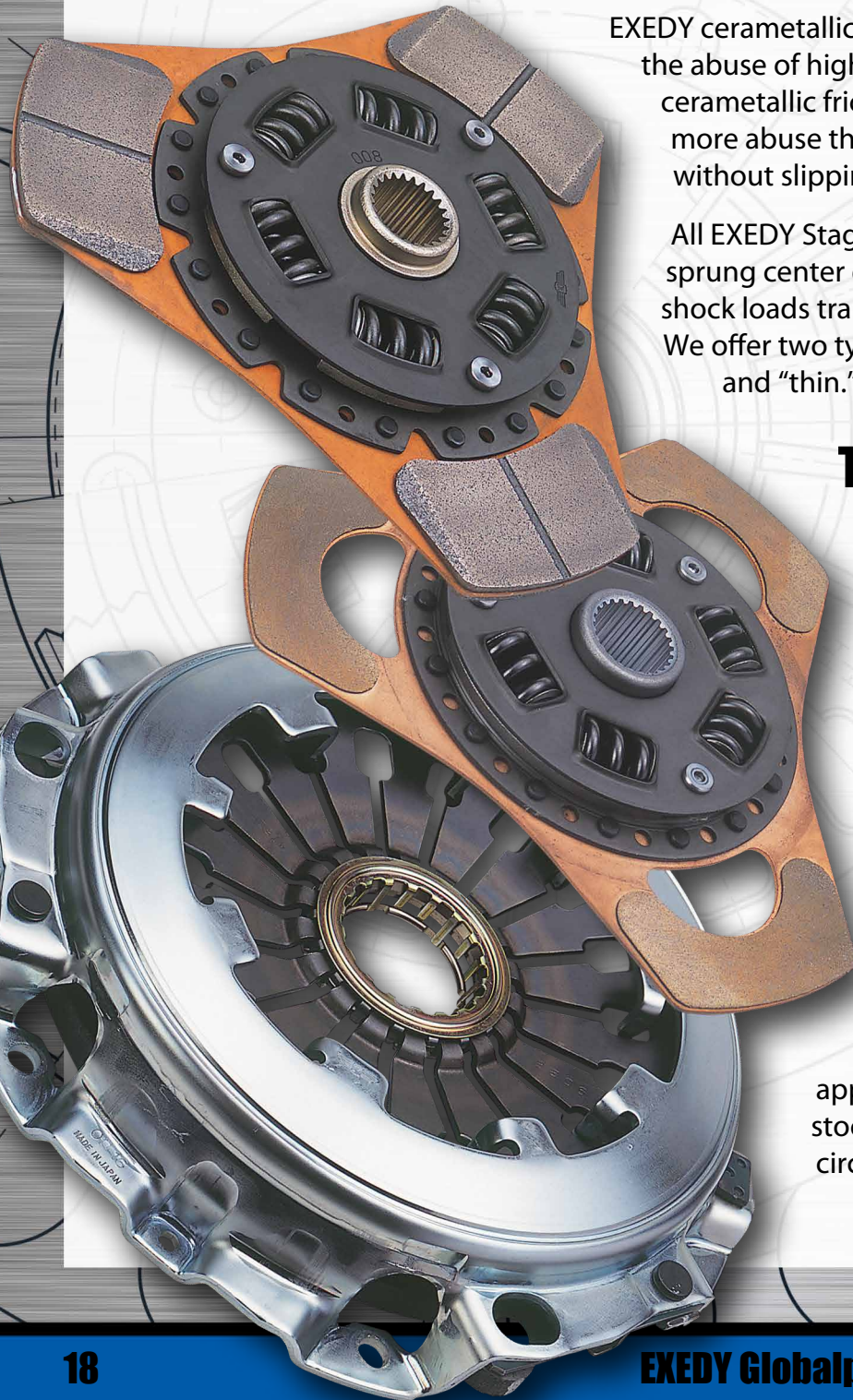

Flywheels - Lightweight One Piece Chromoly

EXEDY flywheels combine low weight, low inertia and high thermal capacity. They are designed for lightly tuned racing cars for drag racing, autocross and rally events, as well as street usage. They are made from solid one-piece billet chromoly steel or chromoly steel forgings. They are specifically designed to reduce weight and inertia for better engine response. Most incorporate special design features to enhance the airflow which improves the cooling of the clutch. The ring gear teeth are integrated onto the flywheel unlike an aluminum flywheel where the ring gear is pressed onto the flywheel and has the possibility of separating from the flywheel due to the different expansion coefficients of aluminum versus steel. EXEDY steel billet and forged steel flywheels have passed engineering tests to 15,000-18,000 rpm. They are guaranteed not to fail to the said rpm, and are all SFI approved.



Stage 1 - Stage 2 - Flywheels

Stage 1 & 2 clutches have a 10-30% higher pedal effort than stock due to higher clamp load.
 Stage 2 thin are for circuit track only! Not for street, rally or drag use.

Application	Engine Size	Year	Engine Code	Clamp Load	STAGE 1				STAGE 2 Thick Pad			
					Kit Part #	Clutch Torque	Flywheel TQ@	Wheels TQ@	Kit Part #	Clutch Torque	Flywheel TQ@	Wheels TQ@
Acura												
CL	2.2L/2.3L	97-99	F22B1/F23	1542	08805	298	238	191	08952	355	276	221
					---	---	---	---	08952P4	355	276	221
Integra	1.8L	90-91	B18A1	1538	08804	297	233	187	08953	355	271	221
Integra	1.7L/1.8L	92-93	B17A/B18A	1538	08800A	297	233	187	08950A	355	271	217
					---	---	---	---	08950AP4	355	271	217
Integra	1.8L	94-01	B18B/B18C	1538	08800B	297	233	187	08950B	355	271	217
					---	---	---	---	08950BP4	355	271	217
RSX Type S	2.0L	02-07	K20	1596	08806	303	241	193	08951	361	280	224
					---	---	---	---	08951P4	361	280	224
RSX	2.0L	02-07	K20	1596	08806FW	303	241	193	08951FW	361	280	224
					---	---	---	---	08951P4FW	361	280	224
TSX	2.4L	03-08	K24	1596	08806FW	303	241	193	08951FW	361	280	224
					---	---	---	---	08951P4FW	361	280	224
Chevrolet												
Camaro, Z28	5.7L	98-02	LS-1	3372	04805FW	820	622	498	04954FW	1014	640	533
Camaro SS	6.2L	10-15	LS-3	3372	04804	820	622	498	04953	1014	640	533
Cavalier	2.3L/2.4L	95-99	LD9	1785	04800	349	277	222	---	---	---	---
Cobalt	2.2L	05-10	L61	1866	04801	360	290	232	04950	435	337	270
Cobalt SS	2.4L	05-10	LE5	1866	04801	360	290	232	04950	435	337	270
Corvette	5.7L	97-04	LS-1/LS-6	3372	04805FW	820	622	498	04954FW	1014	640	533
Corvette	6.0L	05-08	LS-2	3372	04803	820	622	498	04952	930	734	587
Corvette	7.0L	06-13	LS-7	3372	04803	820	622	498	04952	930	734	587
Corvette	6.2L	09-13	LS-3	3372	04803	820	622	498	04952	930	734	587
HHR	2.4L	06-07	LE5	1866	04801	360	290	232	04950	435	337	270
Nova	1.6L	85-88	4ALC	1212	16804B	212	169	133	16954B	253	196	157
Chrysler												
Conquest	2.6L	88-90	G54B	1895	10803B	390	310	248	10952B	453	361	295
Conquest	2.6L	88-90	G54B	2360	10803BHD	486	387	310	10952BHD	564	450	360

STAGE 2 Thin Pad				Disc Size (mm)	Spline Teeth/ Major Dia (mm)	Light Weight Flywheel		Notes	Standard Clutch Kit Part #
Kit Part #	Clutch Torque	Flywheel TQ@	Wheels TQ@			Part #	Weight (lb)		
08901	355	276	221	220	24T/26	---	---	---	08014
---	---	---	---	220	24T/26	---	---	4 Puck design disc	08014
08903	355	275	220	220	24T/25	HF01	9.5	Cable type clutch	08017
08900A	355	275	220	220	24T/26	HF01	9.5	GSR/VTEC, Cable clutch	08028
---	---	---	---	220	24T/26	HF01	9.5	4 Puck design disc, GSR/VTEC, Cable clutch	08028
08900B	355	275	220	220	24T/26	HF01	9.5	Hydraulic clutch	KHC05
---	---	---	---	220	24T/26	HF01	9.5	4 Puck design disc	KHC05
08905	361	307	246	215	24T/26	HF02	8.9	6 Speed	KHC10
---	---	---	---	215	24T/26	HF02	8.9	6 Speed, 4 Puck design disc	KHC10
---	---	---	---	215	24T/26	HF02	8.9	5 Speed, RSX (non Type S), Must use HF02 flywheel, Kit includes flywheel, Light flywheel requires tuning/re-flash for use	KHC09
---	---	---	---	215	24T/26	HF02	8.9	6 Speed, RSX (non Type S), Must use HF02 flywheel, Kit includes flywheel, Light flywheel requires tuning/re-flash for use	KHC09
---	---	---	---	215	24T/26	HF02	8.9	Must use HF02 flywheel, Kit includes flywheel, Light flywheel requires tuning/re-flash for use	HCK1001
---	---	---	---	215	24T/26	HF02	8.9	Must use HF02 flywheel, Kit includes flywheel, Light flywheel requires tuning/re-flash for use	HCK1001
---	---	---	---	290	26T/29	GF502A	18	Cushion button type Stage 2 disc, 6 Speed, Must change flywheel to GF502 when using performance clutch kit (#04805FW, #04954FW), Includes flywheel	04173
---	---	---	---	290	26T/29.4	GF502A	18	Kit includes the CSC hydraulic slave cylinder assembly (BRG0175)	GMK1036
---	---	---	---	225	14T/25	---	---	---	04158
---	---	---	---	225	14T/25	GF501A	10.5	Natural aspirated, Does not include CSC hydraulic slave cylinder (BRG0143)	GMK1010
---	---	---	---	225	14T/25	GF501A	10.5	Natural aspirated, Does not include CSC hydraulic Slave Cylinder (BRG0143)	GMK1010
---	---	---	---	280	26T/29	GF502A	18	C5, 6 Speed, Must change flywheel to GF502A when using performance clutch kit. Kit includes flywheel	04173
---	---	---	---	290	26T/29.4	GF502A	18	Kit includes the CSC hydraulic slave cylinder assembly, C6, 6 Speed (BRG0167)	GMK1035
---	---	---	---	290	26T/29.4	GF502A	18	Kit includes the CSC hydraulic slave cylinder assembly (BRG0167)	GMK1035
---	---	---	---	290	26T/29.4	GF502A	18	Kit includes the CSC hydraulic slave cylinder assembly (BRG0167)	GMK1035
---	---	---	---	225	14T/25	GF501A	10.5	Natural aspirated, Does not include CSC hydraulic slave cylinder (BRG0143)	GMK1010
---	---	---	---	200	21T/24.1	---	---	Fuel injected	16042
10902B	453	361	295	236	23T/26.2	---	---	Turbo	05049
---	---	---	---	236	23T/26.2	---	---	Turbo, If 1988-90 flywheel is used, these clutches can be applied to 1984-87 models (originally 225mm clutch)	05049

Stage 1 - Stage 2 - Flywheels

Application	Engine Size	Year	Engine Code	Clamp Load	STAGE 1				STAGE 2 Thick Pad				
					Kit Part #	Clutch Torque	TQ@ Flywheel	TQ@ Wheels	Kit Part #	Clutch Torque	TQ@ Flywheel	TQ@ Wheels	
Dodge													
Colt Vista	2.4L	92-94	4G64	2136	05800	413	329	264	05950	492	381	305	
Dakota	3.9L	92-99	---	2473	01800	550	417	314	01950	639	490	374	
Stealth	3.0L	91-96	6G72	2136	05800	413	329	264	05950	492	381	305	
					---	---	---	---	05950P4	492	381	305	
Ram Truck	5.9L	01-04	---	3260	---	---	---	---	CRK1004HD	995	890	675	
Ram Truck	5.9L	01-04	---	4036	05805XHD	1336	840	635	05954XHD	1336	1000	760	
Ram Truck	5.9L	05-10	---	3260	---	---	---	---	CRK1005FWHD	995	890	975	
Ram Truck	5.9L	05-17	---	4036	05806FWXHD	1336	840	635	05955FWXHD	1336	1000	760	
Eagle													
Summit	2.4L	92-96	4G64	2136	05800	413	329	264	05950	492	381	305	
					---	---	---	---	05950P4	492	381	305	
Talon	2.0L	90-94	4G63	1544	05801	283	225	180	05951	328	261	209	
Talon	2.0L	90-4/92	4G63T	2136	05800	413	329	264	05950	492	381	305	
					---	---	---	---	05950P4	492	381	305	
Talon	2.0L	5/92-98	4G63T	2136	05800	413	329	264	05950	492	381	305	
					---	---	---	---	05950P4	492	381	305	
Talon	2.0L	90-4/92	4G63T	2136	05800	413	329	264	05950	492	381	305	
					---	---	---	---	05950P4	492	381	305	
Talon	2.0L	5/92-98	4G63T	2136	05800	413	329	264	05950	492	381	305	
					---	---	---	---	05950P4	492	381	305	
Ford													
Escort/ZX2	2.0L	97-03	Zetec	1543	10801	298	238	191	10958	356	276	221	
F250-F350	7.3L	99-03	---	2997	---	---	---	---	FMK1008HD	998	816	680	
Focus	2.0/2.3L	04-07	Duratec	1566	07804	304	241	193	07954	361	280	224	
Fusion	2.3L	06-07	L3-VE	1543	10807	302	242	202	10956	361	276	221	
Mustang	4.0L	05-10	---	2271	07808FW	481	383	307	---	---	---	---	
Mustang	5.0L	86-95	---	2608	07800	586	438	365	07950	699	498	415	
Mustang	5.0L	86-95	---	2608	07801	586	438	365	07951	699	498	415	

STAGE 2 Thin Pad				Disc Size (mm)	Splines Teeth/ Major Dia (mm)	Light Weight Flywheel		Notes	Standard Clutch Kit Part #
Kit Part #	Clutch Torque	Flywheel TQ@	TQ@ Wheels			Part #	Weight (lb)		
05900	479	347	278	225	20T/22.4	---	---	---	05048A
---	---	---	---	265	10T/28.5	---	---	---	05065
05900	479	347	278	225	20T/22.4	---	---	2WD, Non-Turbo	05048
---	---	---	---	225	20T/22.4	---	---	4 Puck design disc, 2WD, Non-Turbo	05048
---	---	---	---	330	10T/35	---	---	Turbo diesel, 6 Speed, Cushion button disc	---
---	---	---	---	330	10T/35	---	---	Turbo diesel, 6 Speed, Cushion button disc	---
---	---	---	---	330	10T/35	---	---	6 Speed turbo diesel, Solid FW replacement for OEM dual mass FW, Includes master and slave cylinder hydraulic system, Includes solid flywheel, Cushion button disc	---
---	---	---	---	330	10T/35	---	---	6 Speed turbo diesel, Solid FW replacement for OEM dual mass FW, Includes master and slave cylinder hydraulic system, Includes solid flywheel, Cushion button disc	---
05900	479	347	278	225	20T/22.4	---	---	Including wagon	05071
---	---	---	---	225	20T/22.4	---	---	4 Puck design disc, Including wagon	05071
---	---	---	---	215	20T/22.4	---	---	Non-Turbo	05051
05900	479	347	278	225	20T/22.4	---	---	Turbo 2WD, 6 bolt crank	05048
---	---	---	---	225	20T/22.4	---	---	4 Puck design disc, Turbo 2WD, 6 bolt crank	05048
05900	479	347	278	225	20T/22.4	---	---	Turbo 2WD, 7 bolt crank	05048
---	---	---	---	225	20T/22.4	---	---	4 Puck design disc, Turbo 2WD, 7 bolt crank	05048
05900	479	347	278	225	20T/22.4	MF03	12.0	Turbo AWD, 6 bolt crank	05048
---	---	---	---	225	20T/22.4	MF03	12.0	4 Puck design disc, Turbo AWD, 6 bolt crank	05048
05900	479	347	278	225	20T/22.4	MF01	12.0	Turbo AWD, 7 bolt crank	05048
---	---	---	---	225	20T/22.4	MF01	12.0	4 Puck design disc, Turbo AWD, 7 bolt crank	05048
---	---	---	---	225	22T/24.3	---	---	SOHC/DOHC	07083
---	---	---	---	330	10T/35	---	---	Turbo diesel, 6 Speed with direct fuel injection. EXEDY version includes solid FW. This kit must be installed as a matched set, Includes cushion button disc	---
---	---	---	---	225	23T/26.2	ZF502	12.5	OEM flywheel (dual mass flywheel) must be changed to ZF502 when using performance clutch kit (#07804, #07954) Also need 6-crank bolts (part #1S7Z-6379-AA) from Dealer.	FMK1009
---	---	---	---	225	22T/24.3	ZF502	12.5	---	FMK1004
---	---	---	---	225	22T/24.3	EF506	22.5	Includes flywheel, Must be used with EF506, Will not work on OEM flywheel, Includes CSC hydraulic slave cylinder	---
---	---	---	---	265	10T/27.5	EF504	13.3 13.0	Contains both 28oz. and 50oz. counter weight	07042
---	---	---	---	265	26T/29	EF504	13.3 13.0	Tremec transmission, Contains both 28oz. and 50oz. counter weight	---

Stage 1 - Stage 2 - Flywheels

Application	Engine Size	Year	Engine Code	Clamp Load	STAGE 1				STAGE 2 Thick Pad			
					Kit Part #	Clutch Torque	Flywheel TQ@	Wheels TQ@	Kit Part #	Clutch Torque	Flywheel TQ@	Wheels TQ@
Ford continued												
Mustang	4.6L	96-04	---	2765	07805	639	510	408	07955	763	576	461
					---	---	---	---	07955P	763	576	461
				2765	07806	639	510	408	07956	763	576	461
					---	---	---	---	07956P	763	576	461
Mustang	4.6L	96-04	---	3372	07802	780	622	498	07952	930	734	587
					---	---	---	---	07952P	930	734	587
Mustang	4.6L	96-04	---	3372	07803	780	622	498	07953	930	734	587
					---	---	---	---	07953P	930	734	587
Mustang	4.6L	05-10	---	2765	07805CSC	639	510	408	07955CSC	763	576	461
					---	---	---	---	07955PCSC	763	576	461
				2765	07806CSC	639	510	408	07956CSC	763	576	461
					---	---	---	---	07956PCSC	763	576	461
Mustang	4.6L	05-10	---	3372	07803CSC	780	622	498	07953CSC	930	734	587
					---	---	---	---	07953PCSC	930	734	587
Mustang	4.6L	05-10	---	3372	07802CSC	780	622	498	07952CSC	930	734	587
					---	---	---	---	07952PCSC	930	734	587
Mustang GT500	5.4L	07-14	---	3372	---	---	---	---	07953FW	930	734	587
				3372	---	---	---	---	07953PFW	930	734	587
Mustang GT	5.0L	11-17	---	3372	07807CSC	780	622	498	07959CSC	930	734	587
				3372	---	---	---	---	07959PCSC	930	734	587
Probe	2.2L	89-92	FE2/FE3	1895	10803A	390	310	248	10952A	435	361	295
Probe	2.2L	89-92	FE2/FE3	2360	10803AHD	486	387	310	10952AHD	580	450	360
GEO												
Prizm	1.6L	89-4/91	4AFE	1212	16804B	212	169	133	16954B	253	196	157
Prizm	1.6L	5/91-92	4AFE	1212	16804C	212	169	133	16954C	253	196	157
Prizm	1.6L	90-97	4AFE	1543	16800	283	225	180	16950	337	261	209
Prizm	1.8L	93-97	3TC	1543	16800	283	225	180	16950	337	261	209

STAGE 2 Thin Pad				Disc Size (mm)	Splines Teeth/ Major Dia (mm)	Light Weight Flywheel		Notes	Standard Clutch Kit Part #
Kit Part #	Clutch Torque	TQ@ Flywheel	TQ@ Wheels			Part #	Weight (lb)		
---	---	---	---	280	10T/27.5	EF503A (6 Bolt)	16.1	GT, Shelby GT, Bullitt, Cushion button disc	FMK1011
---	---	---	---	280	10T/27.5	EF502A (8 Bolt)	16.1	GT, Shelby GT, Bullitt, Paddle style disc	FMK1011
---	---	---	---	280	26T/29	EF503A (6 Bolt)	16.1	GT, Shelby GT, Bullitt, Tremec transmission, Cushion button disc	FMK1012
---	---	---	---	280	26T/29	EF502A (8 Bolt)	16.1	GT, Shelby GT, Bullitt, Tremec transmission, Paddle style disc	FMK1012
---	---	---	---	280	10T/27.5	EF503A (6 Bolt)	16.1	Cobra, GT, Mach-1, Cushion button disc	KFM10
---	---	---	---	280	10T/27.5	EF502A (8 Bolt)	16.1	Cobra, GT, Mach-1, Paddle style disc	KFM10
---	---	---	---	280	26T/29	EF503A (6 Bolt)	16.1	Tremec transmission, Cushion button disc	---
---	---	---	---	280	26T/29	EF502A (8 Bolt)	16.1	Tremec transmission, Paddle style disc	---
---	---	---	---	280	10T/27.5	EF503A (6 Bolt)	16.1	GT, Shelby GT, Bullitt, Cushion button disc	FMK1011
---	---	---	---	280	10T/27.5	EF502A (8 Bolt)	16.1	GT, Shelby GT, Bullitt, Paddle Style Disc	FMK1011
---	---	---	---	280	26T/29	EF503A (6 Bolt)	16.1	GT, Shelby GT, Bullitt, Tremec transmission, Cushion button disc	FMK1012
---	---	---	---	280	26T/29	EF502A (8 Bolt)	16.1	GT, Shelby GT, Bullitt, Tremec transmission, Paddle style disc	FMK1012
---	---	---	---	280	26T/29	EF503A (6 Bolt)	16.1	Tremec transmission, Cushion button disc, Includes hydraulic concentric slave cylinder	FMK1012
---	---	---	---	280	26T/29	EF502A (8 Bolt)	16.1	Tremec transmission, Paddle style disc, Includes hydraulic concentric slave cylinder	FMK1012
---	---	---	---	280	10T/27.5	EF503A (6 Bolt)	16.1	Cobra, GT, Mach-1, Cushion button disc, Includes hydraulic concentric slave cylinder	FMK1011
---	---	---	---	280	10T/27.5	EF502A (8 Bolt)	16.1	Cobra, GT, Mach-1, Paddle style disc, Includes hydraulic concentric slave cylinder	FMK1011
---	---	---	---	280	26T/29	EF502A (8 Bolt)	16.1	Shelby GT500/GT500KR, Cushion button disc, Includes CSC hydraulic slave cylinder, Includes flywheel	---
---	---	---	---	280	26T/29	EF502A (8 Bolt)	16.1	Shelby GT500/ GT500KR, Paddle style disc, Includes CSC hydraulic slave cylinder, Includes flywheel	---
---	---	---	---	280	23T/26.2	EF502A (8 Bolt)	16.1	Cushion button Stage 2 disc, Includes hydraulic concentric slave cylinder	---
---	---	---	---	280	23T/26.2	EF502A (8 Bolt)	16.1	Paddle style Stage 2 disc, Includes hydraulic concentric slave cylinder	---
10902A	435	361	295	236	23T/26.2	---	---	Turbo	07067
---	---	---	---	236	23T/26.2	---	---	Turbo	07067
---	---	---	---	200	21T/24.1	---	---	SOHC	16070
---	---	---	---	200	21T/24.1	---	---	SOHC	16070
---	---	---	---	215	21T/24.1	---	---	---	KTY03
---	---	---	---	215	21T/24.1	---	---	---	KTY03

Stage 1 - Stage 2 - Flywheels

Application	Engine Size	Year	Engine Code	Clamp Load	STAGE 1				STAGE 2 Thick Pad			
					Kit Part #	Clutch Torque	TQ@ Flywheel	TQ@ Wheels	Kit Part #	Clutch Torque	Flywheel TQ@	Wheels TQ@
Honda Accord	2.2L	90-97	F22	1542	08805	298	238	191	08952	355	276	221
					---	---	---	---	08952P4	355	276	221
Honda Accord	2.3L	90-02	F23	1542	08805	298	238	191	08952	355	276	221
					---	---	---	---	08952P4	355	276	221
Honda Accord	2.4L	03-07	K24	1596	08806FW	303	241	193	08951FW	361	280	224
					---	---	---	---	08951P4FW	361	280	224
Honda Civic	1.5L	88	D15	991	08802	181	138	111	---	---	---	---
Honda Civic	1.5L	89	D15	991	08803	181	138	111	---	---	---	---
Honda Civic	1.5L	90-91	D15	1454	08801B	284	227	182	---	---	---	---
Honda Civic	1.5L	92-95	D15	1454	08801A	284	227	182	---	---	---	---
Honda Civic	1.6L	89	D16	991	08803	181	138	111	---	---	---	---
Honda Civic	1.6L	90-91	D16	1454	08801B	284	227	182	---	---	---	---
Honda Civic	1.6L	92-00	D16	1454	08801A	284	227	182	---	---	---	---
Honda Civic	1.7L	01-05	D17	1454	08801A	284	227	182	---	---	---	---
Honda Civic	1.8L	06-15	R18	1567	08808	294	220	294	08955	345	259	345
Honda Civic	1.5L	16-19	L15B7	1651	08809	378	270	235	08956	382	295	255
Honda Civic SI	1.6L	99-00	B16A	1538	08800B	297	233	187	08950B	355	271	217
					---	---	---	---	08950BP4	355	271	217
Honda Civic SI	2.0L	02-05	K20	1596	08806FW	303	241	193	08951FW	361	280	224
					---	---	---	---	08951P4FW	361	280	224
Honda Civic SI	2.0L	06-11	K20	1596	08806	303	241	193	08951	361	280	224
					---	---	---	---	08951P4	361	280	224
Honda Civic SI	2.4L	12-15	K24	1596	08806FW	303	241	193	08951FW	361	280	224
					---	---	---	---	08951P4FW	361	280	224
Honda Civic SI	1.5L	17-19	L15B7	1651	08809	378	270	235	08956	382	295	255
Honda Civic Wagon	1.5L	88	D15	991	08802	181	138	111	---	---	---	---
Honda Civic Wagon	1.5L	89	D15	991	08803	181	138	111	---	---	---	---
Honda Civic Wagon	1.5L	90-91	D15	1454	08801B	284	227	182	---	---	---	---
Honda Civic Wagon	1.6L	90-91	D16	1454	08801C	284	227	182	---	---	---	---
Honda CRX	1.5L	88	D15	991	08802	181	138	111	---	---	---	---
Honda CRX	1.5L	89	D15	991	08803	181	138	111	---	---	---	---
Honda CRX	1.5L	90-91	D15	1454	08801B	284	227	182	---	---	---	---
Honda CRX	1.6L	88	D16	991	08802	181	138	111	---	---	---	---
Honda CRX	1.6L	89	D16	991	08803	181	138	111	---	---	---	---

STAGE 2 Thin Pad				Disc Size (mm)	Spline Teeth/ Major Dia (mm)	Light Weight Flywheel		Notes	Standard Clutch Kit Part #
Kit Part #	Clutch Torque	TQ@ Flywheel	TQ@ Wheels			Part #	Weight (lb)		
08901	355	276	221	220	24T/26	---	---	---	08014
---	---	---	---	220	24T/26	---	---	4 Puck design disc	08014
08901	355	276	221	220	24T/26	---	---	---	HCK1000
---	---	---	---	220	24T/26	---	---	4 Puck design disc	HCK1001
---	---	---	---	215	24T/26	HF02	8.9	5 Speed, Must use HF02, Kit includes flywheel, Light flywheel requires tuning/re-flash for use	HCK1005
---	---	---	---	215	24T/26	HF02	8.9	5 Speed, 4 Puck design disc, Must use HF02, Kit includes flywheel, Light flywheel requires tuning/re-flash for use	HCK1006
---	---	---	---	200	21T/22	---	---	---	08009
---	---	---	---	200	20T/22	---	---	If the HF501 is used, the higher capacity clutch can be used (# 08801B, #08902B)	08011
08902B	322	266	213	212	20T/22	HF501	10.9	---	08012
08902A	322	266	213	212	20T/22	HF501	10.9	---	08022
---	---	---	---	200	20T/22	---	---	If the HF501 is used, the higher capacity clutch can be used (# 08801B, #08902B)	08011
08902B	322	266	213	212	20T/22	HF501	10.9	SOHC	08012
08902A	322	266	213	212	20T/22	HF501	10.9	SOHC	08022
08902A	322	266	213	212	20T/22	HF501	10.9	SOHC	KHC08
---	---	---	---	215	20T/22	HF02	8.9	---	HCK1002
---	---	---	---	230	24T / 26	HF03	---	Works with OEM dual-mass FW or EXEDY lightweight solid flywheel	---
08900B	322	275	220	220	24T/26	HF01	9.5	VTEC / DOHC	KHC05
---	---	---	---	220	24T/26	HF01	9.5	4 Puck design disc, VTEC / DOHC	KHC05
---	---	---	---	215	24T/26	HF02	8.9	5 Speed, Must use HF02, Kit includes flywheel, Light flywheel requires tuning/re-flash for use	KHC09
---	---	---	---	215	24T/26	HF02	8.9	4 Puck design disc, 5 speed, Must use HF02, Kit includes flywheel, Light flywheel requires tuning/re-flash for use	KHC09
08905	361	307	246	215	24T/26	HF02	8.9	6 speed	KHC10
---	---	---	---	215	24T/26	HF02	8.9	4 Puck design disc, 6 Speed	KHC10
---	---	---	---	215	24T/26	HF02	8.9	6 Speed include flywheel, Light flywheel requires tuning/re-flash for use	---
---	---	---	---	215	24T/26	HF02	8.9	6 Speed include flywheel, Light flywheel requires tuning/re-flash for use	---
---	---	---	---	230	24T / 26	HF03	19.4	Works with OEM dual-mass FW or EXEDY lightweight solid flywheel	---
---	---	---	---	200	21T/22	---	---	2WD	08009
---	---	---	---	200	20T/22	---	---	If the HF501 is used, the higher capacity clutch can be used (# 08801B, #08902B)	08011
08902B	322	266	213	212	20T/22	HF501	10.9	2WD	08012
08902C	322	266	213	212	20T/22	HF501	10.9	AWD	08020
---	---	---	---	200	21T/22	---	---	---	08009
---	---	---	---	200	20T/22	---	---	If the HF501 is used, the higher capacity clutch can be used (# 08801B, #08902B)	08011
08902B	322	266	213	212	20T/22	HF501	10.9	---	08012
---	---	---	---	200	21T/22	---	---	Fuel Injected	08010
---	---	---	---	200	20T/22	---	---	If the HF501 is used, the higher capacity clutch can be used (# 08801B, #08902B)	08011

Stage 1 - Stage 2 - Flywheels

Application	Engine Size	Year	Engine Code	Clamp Load	STAGE 1				STAGE 2 Thick Pad				
					Kit Part #	Clutch Torque	Flywheel TQ@	TQ@ Wheels	Kit Part #	Clutch Torque	Flywheel TQ@	TQ@ Wheels	
Honda continued													
CRX	1.6L	90-91	D16	1454	08801B	284	227	182	---	---	---	---	
Del Sol	1.5/1.6L	93-95	D15/D16	1454	08801A	284	227	182	---	---	---	---	
Del Sol	1.6L	96-97	D16	1454	08801A	284	227	182	---	---	---	---	
Del Sol	1.6L	94-97	B16A	1538	08800B	297	233	187	08950B	355	271	217	
					---	---	---	---	08950BP4	355	271	217	
Fit	1.5L	06-08	L15A1	1259	08807	208	166	133	08954	249	197	158	
Prelude	2.2L	92-01	F22/H22	1542	08805	298	238	191	08952	355	276	221	
					---	---	---	---	08952P4	355	276	221	
Prelude	2.3L	92-96	H23A	1542	08805	298	238	191	08952	355	276	221	
					---	---	---	---	08952P4	355	276	221	
Infiniti													
G20	2.0L	91-96	SR20DE	1544	06802	289	230	184	---	---	---	---	
G35	3.5L	03-06	VQ35DE	2271	06804	481	383	307	06952	574	444	355	
G35	3.5L	03-06	VQ35DE	2271	06804FW	481	383	307	06952FW	574	444	355	
G35	3.5L	07	VQ35DE	2271	06804	481	383	307	06952	574	444	355	
G35	3.5L	07	VQ35DE	2271	06804FW	481	383	307	06952FW	574	444	355	
G35	3.5L	07	VQ35HR	2271	06807	481	383	307	06956	574	444	355	
G37	3.7L	08-15	VQ37VHR	2271	06807	481	383	307	06956	574	444	355	
Jeep													
Cherokee	4.2L	87-89	---	2473	01802	550	417	314	01952	639	490	374	
Cherokee	4.0/4.2L	89-93	---	2473	01803	550	417	314	01953	639	490	374	
Cherokee	4.0L	94-01	---	2473	01800	550	417	314	01950	639	490	374	
Cherokee	4.0/4.2L	84-11	---	2473	01801LB	550	417	314	01951LB	639	490	374	
Liberty	3.7	02-04	---	2473	01800	550	417	314	01950	639	490	374	
Liberty	3.7	02-04	---	2473	01801LB	550	417	314	01951LB	639	490	374	
Wrangler	4.2L	87-89	---	2473	01802	550	417	314	01952	639	490	374	
Wrangler	4.0/4.2L	89-93	---	2473	01803	550	417	314	01953	639	490	374	
Wrangler	4.0L	94-06	---	2473	01800	550	417	314	01950	639	490	374	
Wrangler	3.8L	07-11	---	2473	01800	550	417	314	01950	639	490	374	
Wrangler	3.8/4.0/4.2L	72-11	---	2473	01801LB	550	417	314	01951LB	639	490	374	
Lexus													
ES250	2.5L	90-91	2VZFE	2093	16803C	431	343	275	16953C	515	399	319	
ES300	3.0L	92-93	3VZFE	2093	16803A	431	343	275	16953A	515	399	319	

STAGE 2 Thin Pad				Disc Size (mm)	Spline Teeth/ Major Dia (mm)	Light Weight Flywheel		Notes	Standard Clutch Kit Part #
Kit Part #	Clutch Torque	Flywheel TQ@	Wheels TQ@			Part #	Weight (lb)		
08902B	322	266	213	212	20T/22	HF501	10.9	---	08012
08902A	322	266	213	212	20T/22	HF501	10.9	SOHC	08022
08902A	322	266	213	212	20T/22	HF501	10.9	S, Si, SOHC, Must change flywheel to HF501 for performance clutch kit (# 08801A, #08902A).	08031
08900B	355	275	220	220	24T/26	HF01	9.5	VTEC/DOHC	KHC05
---	---	---	---	220	24T/26	HF01	9.5	4 Puck design disc, VTEC/DOHC	KHC05
---	---	---	---	190	20/22.2	---	---	L15A1	HCK1006
08901	355	276	221	220	24T/26	---	---	---	KHC03
---	---	---	---	220	24T/26	---	---	4 Puck design disc	KHC03
08901	355	276	221	220	24T/26	---	---	---	KHC03
---	---	---	---	220	24T/26	---	---	4 Puck design disc	KHC03
06902	270	203	154	215	18T/20.6	---	---	---	KNS02
---	---	---	---	250	24T/25.6	NF04	19.6	Coupe and Sedan (6 Speed only), Recommended for use with EXEDY solid flywheel (NF04), will also work with OE dual-mass flywheel.	NSK1000
---	---	---	---	250	24T/25.6	NF04	19.6	Coupe and Sedan (6 Speed only), Includes NF04 flywheel	NSK1000FW
---	---	---	---	250	24T/25.6	NF04	19.6	Coupe only, Recommended for use with EXEDY solid flywheel (NF04), will also work with OE dual-mass flywheel.	NSK1000
---	---	---	---	250	24T/25.6	NF04	19.6	Coupe only, Includes NF04 flywheel	NSK1000FW
---	---	---	---	250	24T/25.6	NF05	19.6	Sedan only, Includes NF05 flywheel, NF05 flywheel only works with EXEDY clutch kits	NSK1024FW
---	---	---	---	250	24T/25.6	NF05	19.6	Includes NF05 flywheel, NF05 flywheel only works with EXEDY clutch kits, DOES NOT include CSC hydraulic slave cylinder (BRG0163)	NSK1024FW
---	---	---	---	265	10T/28.5	---	---	Stage 2 cushion button disc; Peugeot transmission	01034
---	---	---	---	265	10T/28.5	---	---	Stage 2 cushion button disc; Aisin transmission	01035
---	---	---	---	265	10T/28.5	---	---	Stage 2 cushion button disc	05065
---	---	---	---	265	10T/28.5	---	---	Stage 2 cushion button disc; Kits DO NOT include bearings	05065
---	---	---	---	265	10T/28.5	---	---	Stage 2 cushion button disc	05065
---	---	---	---	265	10T/28.5	---	---	Stage 2 cushion button disc; Kits DO NOT include bearings	05065
---	---	---	---	265	10T/28.5	---	---	Stage 2 cushion button disc; Peugeot transmission	01034
---	---	---	---	265	10T/28.5	---	---	Stage 2 cushion button disc; Aisin transmission	01035
---	---	---	---	265	10T/28.5	---	---	Stage 2 cushion button disc	05065
---	---	---	---	265	10T/28.5	---	---	Stage 2 cushion button disc	KJP02
---	---	---	---	265	10T/28.5	---	---	Stage 2 cushion button disc; Kits DO NOT include bearings	05065
---	---	---	---	240	21T/29.8	---	---	---	16082
---	---	---	---	240	21T/29.8	---	---	---	16082

Stage 1 - Stage 2 - Flywheels

Application	Engine Size	Year	Engine Code	Clamp Load	STAGE 1				STAGE 2 Thick Pad			
					Kit Part #	Clutch Torque	Flywheel TQ@	TQ@ Wheels	Kit Part #	Clutch Torque	Flywheel TQ@	TQ@ Wheels
Lotus												
ELISE	1.8L	05-07	2ZZ-GE	1543	16800	283	225	180	16950	328	261	209
EXIGE	1.8L	06-07	2ZZ-GE	1543	16800	283	225	180	16950	328	261	209
Mazda												
Mazda 3	2.0/2.3L	04-07	LF-DE/L3-VE	1566	10809	302	241	193	10955	351	280	224
Mazda 5	2.3L	06-08	---	1566	10809	302	241	193	10955	351	280	224
Mazda 6	2.3L	03-08	L3-VE	1543	10807	298	238	191	10956	346	276	221
Mazda 6	3.0L	03-08	AJV	1978	10808	407	324	259	---	---	---	---
626/MX6	2.2L	88-92	F2	1895	10803A	390	310	248	10952A	435	361	295
626/MX6	2.2L	88-92	F2	2360	10803AHD	486	387	310	10952AHD	564	450	360
929	3.0L	88-91	JE	1895	10803A	390	310	248	10952A	435	361	295
929	3.0L	88-91	JE	2360	10803AHD	486	387	310	10952AHD	564	450	360
Miata	1.6L	90-93	B6-ZE	1169	10804	204	163	131	10950	237	189	152
MX-5 Miata	1.8L	94-05	BP-ZE	1322	10805	256	204	164	10951	297	236	189
MX-5 Miata	2.0L	06-15	VE	1543	10811	298	238	191	10959	351	262	202
MX-5 Miata	2.0L	06-15	VE	1543	10810	298	238	191	---	---	---	---
MX-5 Miata	2.0L	16-18	Skyactiv	1675	10814	320	240	195	10960	370	280	225
Protégé	2.0L	04	FS-DE/ZE	1543	10807	298	238	191	10956	346	276	221
Protégé	2.0L	03-04	FS-DET	1543	10807	298	238	191	10956	346	276	221
RX-7	1.2/1.3L	84-91	12A/13B	1574	10806	304	242	196	10954	405	322	258
RX-7	1.3L	86-91	13B-RE	1895	10803A	390	310	248	10952A	435	361	295
RX-7	1.3L	86-91	13B-RE	2360	10803AHD	486	387	310	10952AHD	564	450	360
RX-7	1.3L	93-95	13B-REW	2093	10802	431	343	275	10953	501	400	320
RX-7	1.3L	93-95	13B-REW	2653	10802HD	546	435	348	10953HD	635	506	405
RX-8	1.3L	03-08	13B-MSP	2001	10812	395	306	232	---	---	---	---
RX-8	1.3L	09-12	13B-MSP	2001	10813	395	306	232	---	---	---	---
Mazda Truck												
B2600	2.6L	87-89	G6	1895	10803A	390	310	248	10952A	435	361	295
B2600	2.6L	87-89	G6	2360	10803AHD	486	387	310	10952AHD	564	450	360
Mercury												
Milan	2.3L	06-07	L3-VE	1543	10807	298	238	191	10956	346	276	221

STAGE 2 Thin Pad				Disc Size (mm)	Spline Teeth/ Major Dia (mm)	Light Weight Flywheel		Notes	Standard Clutch Kit Part #
Kit Part #	Clutch Torque	TQ@ Flywheel	TQ@ Wheels			Part #	Weight (lb)		
---	---	---	---	215	21T/24.1	---	---	---	---
---	---	---	---	215	21T/24.1	---	---	---	---
---	---	---	---	225	22T/24.3	ZF501A	13.0	Non-Turbo	MZK1003
---	---	---	---	225	22T/24.3	ZF501A	13.0	Non-Turbo	MZK1003
---	---	---	---	225	22T/24.3	ZF502	12.5	Non-Turbo	MZK1000
---	---	---	---	240	23T/26.2	ZF503	16.5	---	MZK1001
10902A	435	361	295	236	23T/26.2	---	---	Turbo	07067
---	---	---	---	236	23T/26.2	---	---	Turbo	07067
10902A	435	361	295	236	23T/26.2	---	---	---	10032
---	---	---	---	236	23T/26.2	---	---	---	10032
10903	237	189	152	200	22T/24.3	---	---	If later model 1.8L flywheel is used, the higher capacity 1.8L clutch (# 10805, #10950) can be used	10036
10901	297	236	189	215	22T/24.3	ZF505	16.5	Includes Mazdaspeed version	KMZ03
---	---	---	---	215	22T/24.3	---	---	5 Speed	MZK1005
---	---	---	---	215	23T/26.2	ZF501A	13.0	6 Speed	MZK1006
---	---	---	---	215	22T/24.3	---	---	6 Speed	MZK1017
---	---	---	---	225	22T/24.3	---	---	---	KMZ08
---	---	---	---	225	22T/24.3	---	---	Mazdaspeed Turbo	---
---	---	---	---	225	22T/24.3	---	---	---	10038
10902A	435	361	295	236	23T/26.2	ZF01	12.0	Turbo, FC3S, When using ZF01 flywheel in vehicles built prior to 1/89 use adapter/counterweight N327-11-521A. Vehicles after 1/89 use adapter/counterweight N351-11-521.	10037
---	---	---	---	236	23T/26.2	ZF01	12.0	Turbo, FC3S, When using ZF01 flywheel in vehicles built prior to 1/89 use adapter/counterweight N327-11-521A. Vehicles after 1/89 use adapter/counterweight N351-11-521.	10037
10900	501	400	320	236	23T/26.4	ZF01	12.0	Turbo, FD3S, When using ZF01 flywheel, use adapter/counterweight N351-11-521.	KMZ01
---	---	---	---	236	23T/26.4	ZF01	12.0	Turbo, FD3S, When using ZF01 flywheel, use adapter/counterweight N351-11-521.	KMZ01
---	---	---	---	236	23T/26.2	ZF01	12.0	When using ZF01 flywheel, use adapter/counterweight N322-11-52X.	MZK1002
---	---	---	---	236	23T/26.2	ZF01	12.0	When using ZF01 flywheel, use adapter/counterweight N322-11-52X.	MZK1014
---	---	---	---	236	23T/26.2	---	---	Carbureted	07067
---	---	---	---	236	23T/26.2	---	---	Carbureted	07067
---	---	---	---	225	22T/24.3	ZF502	12.5	---	FMK1004

Stage 1 - Stage 2 - Flywheels

Application	Engine Size	Year	Engine Code	Clamp Load	STAGE 1				STAGE 2 Thick Pad			
					Kit Part #	Clutch Torque	TQ@ Flywheel	TQ@ Wheels	Kit Part #	Clutch Torque	TQ@ Flywheel	TQ@ Wheels
Mitsubishi												
3000GT	3.0L	91-99	6G72	2136	05800	412	329	264	05950	479	381	305
					---	---	---	---	05950P4	479	381	305
Eclipse	2.0L	90-94	4G63	1544	05801	283	225	180	05951	328	261	209
Eclipse	2.0L	90-4/92	4G63T	2136	05800	412	329	264	05950	479	381	305
					---	---	---	---	05950P4	479	381	305
Eclipse	2.0L	5/92-99	4G63T	2136	05800	412	329	264	05950	479	381	305
					---	---	---	---	05950P4	479	381	305
Eclipse	2.0L	90-4/92	4G63T	2136	05800	412	329	264	05950	479	381	305
					---	---	---	---	05950P4	479	381	305
Eclipse	2.0L	5/92-99	4G63T	2136	05800	412	329	264	05950	479	381	305
					---	---	---	---	05950P4	479	381	305
Eclipse	2.4L	96-99	4G64	2136	05800	412	329	264	05950	479	381	305
					---	---	---	---	05950P4	479	381	305
Eclipse Spyder	2.0L	96-99	4G63T	2136	05800	412	329	264	05950	479	381	305
					---	---	---	---	05950P4	479	381	305
Eclipse Spyder	2.4L	96-99	4G64	2136	05800	412	329	264	05950	479	381	305
					---	---	---	---	05950P4	479	381	305
Eclipse Spyder	3.0L	00-05	6G72	1653	05804	341	272	218	05953	396	315	352
Expo/Expo LRV	2.4L	92-95	4G64	2136	05800	412	329	264	05950	479	381	305
					---	---	---	---	05950P4	479	381	305
Galant	2.0L	91-92	4G63T	2136	05800	412	329	264	05950	479	381	305
					---	---	---	---	05950P4	479	381	305
Galant	2.4L	94-97	4G64	2136	05800	412	329	264	05950	479	381	305
					---	---	---	---	05950P4	479	381	305
Lancer Evo 4-7	2.0L	01-02	4G63T	3012	05803	620	495	396	05952	721	575	460
Lancer Evo 4-7	2.0L	01-02	4G63T	3597	05803HD	741	590	472	05952HD	860	685	548
Lancer Evo 8/MR/9	2.0L	03-07	4G63T	3012	05803	620	495	396	05952	721	575	460
Lancer Evo 8/MR/9	2.0L	03-07	4G63T	3597	05803HD	741	590	472	05952HD	860	685	548
Lancer Evo 10	2.0L	08-15	4B11T	3012	05803A	620	495	396	05952A	721	575	460
Lancer Evo 10	2.0L	08-15	4B11T	3597	05803AHD	741	590	472	05952AHD	860	685	548
Starion	2.6L	88-90	G54B	1895	10803B	390	310	248	10952B	453	361	295
Starion	2.6L	88-90	G54B	2360	10803BHD	486	387	310	10952BHD	564	450	360
Nissan												
200SX	2.2L	82-83	Z22E	1798	06805A	347	276	221	06953A	403	320	256
200SX	2.0L	95-99	SR20DE	1544	06802	289	230	184	---	---	---	---
200SX	3.0L	87-88	VG30	2017	06801A	422	335	268	06955A	490	390	312
240SX	2.4L	89-6/90	KA24E	1798	06805A	347	276	221	06953A	403	320	256
240SX	2.4L	7/90-1/94	KA24DE	1798	06805B	347	276	221	06953B	403	320	256
240SX	2.4L	2/94-2/96	KA24DE	1798	06805A	347	276	221	06953A	403	320	256
240SX	2.4L	3/96-98	KA24DE	1798	06805B	347	276	221	06953B	403	320	256
280Z	2.8L	75-78	L28E	1798	06805A	347	276	221	06953A	403	320	256

STAGE 2 Thin Pad				Disc Size (mm)	Splines Teeth/ Major Dia (mm)	Light Weight Flywheel		Notes	Standard Clutch Kit Part #
Kit Part #	Clutch Torque	TA@ Flywheel	TA@ Wheels			Part #	Weight (lb)		
05900	479	347	278	225	20T/22.4	---	---	2WD, Non-Turbo	05048
---	---	---	---	225	20T/22.4	---	---	4 Puck design, 2WD, Non-Turbo	05048
---	---	---	---	215	20T/22.4	---	---	Non-Turbo	05051
05900	479	347	278	225	20T/22.4	---	---	2WD Turbo, 6 bolt crank	05048
---	---	---	---	225	20T/22.4	---	---	4 Puck design, 2WD Turbo, 6 bolt crank	05048
05900	479	347	278	225	20T/22.4	---	---	2WD Turbo, 7 bolt crank	05048
---	---	---	---	225	20T/22.4	---	---	4 Puck design disc, 2WD Turbo, 7 bolt crank	05048
05900	479	347	278	225	20T/22.4	MF03	12.0	AWD Turbo, 6 bolt crank	05048
---	---	---	---	225	20T/22.4	MF03	12.0	4 Puck design disc, AWD Turbo, 6 bolt crank	05048
05900	479	347	278	225	20T/22.4	MF01	12.0	AWD Turbo, 7 bolt crank	05048
---	---	---	---	225	20T/22.4	MF01	12.0	4 Puck design disc, AWD Turbo, 7 bolt crank	05048
05900	479	347	278	225	20T/22.4	---	---	---	05048
---	---	---	---	225	20T/22.4	---	---	4 Puck design disc	05048
05900	479	347	278	225	20T/22.4	---	---	2WD Turbo, 7 bolt crank	05048
---	---	---	---	225	20T/22.4	---	---	4 Puck design disc, 2WD Turbo, 7 bolt crank	05048
05900	479	347	278	225	20T/22.4	---	---	---	05048
---	---	---	---	225	20T/22.4	---	---	4 Puck design disc	05048
---	---	---	---	236	23T/26.2	---	---	Pull type	KMB02/ MBK1003
05900	479	347	278	225	20T/22.4	---	---	---	05048
---	---	---	---	225	20T/22.4	---	---	4 Puck design disc	05048
05900	479	347	278	225	20T/22.4	MF03	12.0	DOHC, Turbo, VR4	05048
---	---	---	---	225	20T/22.4	MF03	12.0	4 Puck design disc, DOHC, Turbo, VR4	05048
05900	479	347	278	225	20T/22.4	---	---	---	05048
---	---	---	---	225	20T/22.4	---	---	4 Puck design disc	05048
---	---	---	---	240	23T/26.2	MF04	12.0	Non US model, Must use MF04 for this application	MBK1002
---	---	---	---	240	23T/26.2	MF04	12.0	Non US model, Must use MF04 for this application	MBK1002
---	---	---	---	240	23T/26.2	MF04	12.0	Pull type, 5 Speed, 6 Speed	MBK1001
---	---	---	---	240	23T/26.2	MF04	12.0	Pull type, 5 Speed, 6 Speed	MBK1001
---	---	---	---	240	23T/26.2	MF05A	12.0	Pull type, 5 Speed	MBK1009
---	---	---	---	240	23T/26.2	MF05A	12.0	Pull type, 5 Speed	MBK1009
10902C	453	323	269	236	23T/26.2	---	---	Turbo	05049
---	---	---	---	236	23T/26.2	---	---	Turbo, If 1988-90 flywheel is used, these clutches can be applied to 1984-87 models (originally 225mm clutch)	05049
---	---	---	---	225	24T/25.6	---	---	SOHC	06004
06902	270	203	154	215	18T/20.6	---	---	---	KNS02
06900A	496	390	312	240	24T/25.6	---	---	---	06031
---	---	---	---	225	24T/25.6	---	---	SOHC	06009
---	---	---	---	225	24T/25.6	---	---	DOHC	06054
---	---	---	---	225	24T/25.6	---	---	DOHC	06009
---	---	---	---	225	24T/25.6	---	---	DOHC	06054
---	---	---	---	225	24T/25.6	---	---	2 Seater, Non-Turbo only	06009

Stage 1 - Stage 2 - Flywheels

Application	Engine Size	Year	Engine Code	Clamp Load	STAGE 1				STAGE 2 Thick Pad			
					Kit Part #	Clutch Torque	TQ@ Flywheel	TQ@ Wheels	Kit Part #	Clutch Torque	Flywheel TQ@	Wheels TQ@
Nissan conintued												
280Z	2.8L	75-78	L28	2017	06801A	422	335	268	06955A	496	390	312
280ZX	2.8L	79-83	L28E	1798	06805A	347	276	221	06953A	403	320	256
280ZX	2.8L	79-83	L28E	2017	06801A	422	335	268	06955A	496	390	312
280ZX	2.8L	82-83	L28ET	2017	06801A	422	335	268	06955A	496	390	312
300ZX	3.0L	84-86	VG30T	2017	06801A	422	335	268	06955A	496	390	312
300ZX	3.0L	84-89	VG30	2017	06801A	422	335	268	06955A	496	390	312
300ZX	3.0L	90-96	VG30DE	2017	06801B	422	335	268	06955B	496	390	312
300ZX	3.0L	90-96	VG30DETT	2021	06806	428	437	364	06954	511	496	413
350Z	3.5L	03-06	VQ35DE	2271	06804	480	383	307	06952	574	444	355
350Z	3.5L	03-06	VQ35DE	2271	06804FW	480	383	307	06952FW	574	444	355
350Z	3.5L	07-09	VQ35HR	2271	06807	480	383	307	06956	574	444	355
370Z	3.7L	09-19	VQ37VHR	2271	06807	480	383	307	06956	574	444	355
810	2.4L	77-81	L24E	1798	06805A	347	276	221	06953A	403	320	256
Altima	3.5L	02-06	VQ35DE	2271	06804A	480	383	307	06952A	574	444	355
Bluebird	2.0L	90-98	SR20DET	1765	06803A	369	295	236	06950A	429	343	275
Maxima	2.4L	81-84	L24E	1798	06805A	347	276	221	06953A	403	320	256
Maxima	2.8L	82-84	LD28	1798	06805A	347	276	221	06953A	403	320	256
Maxima	3.0L	85-01	VG30D/DE/ VQ30	1765	06803A	369	295	236	06950A	429	343	275
Maxima	3.5L	02-06	VQ35DE	2271	06804A	480	383	307	06952A	558	444	355
NX Coupe	2.0L	91-93	SR20DE	1544	06802	289	230	184	---	---	---	---
Pulsar GTI-R	2.0L	90-98	SR20DET	1765	06803A	369	295	236	06950A	429	343	275
Sentra	2.0L	91-99	SR20DE	1544	06802	289	230	184	---	---	---	---
Skyline GTR R32 (early)	2.6L	8/89-2/93	RB26DETT	2020	06810	500	375	300	06957	580	440	350
Skyline GTR R32 (late)	2.6L	3/93-94	RB26DETT	2654	06811	570	425	340	06958	660	490	400
Skyline GTR R33	2.6L	95-98	RB26DETT	2654	06811	570	425	340	06958	660	490	400
Silvia S13/S14	2.0L	93-99	SR20DET	1765	06803B	369	295	236	06950B	429	343	275
Silvia S15	2.0L	3/99-00	SR20DET	1765	06803B	369	295	236	06950B	429	343	275
Nissan Truck												
Axxess	2.4L	89-90	KA24	2017	06801A	422	335	268	06955A	496	390	312
Frontier	2.4L	99-02	KA24DE	2017	06801B	422	335	268	06955B	496	390	312
Pathfinder	2.4L	87-93	Z24	2017	06801A	422	335	268	06955A	496	390	312
Pick-Up (620/720)	2.0L, 2.2L	75-83	L20B/Z20/ Z22/SD22	1798	06805A	347	276	221	06953A	403	320	256
Pick-Up	2.0L	83-85	Z20	2017	06801A	422	335	268	06955A	469	390	312
Pick-Up	2.4L	9/86-90	Z24L	1798	06805A	347	276	221	06953A	403	320	256
Pick-Up	2.4L	83-92	Z24/KA24	2017	06801A	422	335	268	06955A	496	390	312
Pick-Up	2.4L	93-98	Z24/KA24E	2017	06801A	422	335	268	06955A	496	390	312

STAGE 2 Thin Pad				Disc Size (mm)	Splines Teeth/ Major Dia (mm)	Light Weight Flywheel		Notes	Standard Clutch Kit Part #
Kit Part #	Clutch Torque	TQ@ Flywheel	TQ@ Wheels			Part #	Weight (lb)		
06900A	496	390	312	240	24T/25.6	---	---	2+2	06030
---	---	---	---	225	24T/25.6	---	---	2 Seater, Non-Turbo only	06009
06900A	496	390	312	240	24T/25.6	---	---	2+2	06030
06900A	496	390	312	240	24T/25.6	---	---	Turbo	06031
06900A	496	390	312	240	24T/25.6	---	---	Single Turbo	06032
06900A	496	390	312	240	24T/25.6	---	---	Non-Turbo	06031
06900B	496	390	312	240	24T/25.6	---	---	Non-Turbo	06045
---	---	---	---	250	24T/25.6	---	---	Twin-Turbo	06046
---	---	---	---	250	24T/25.6	NF04	19.6	Recommended for use with EXEDY solid flywheel (NF04), will also work with OE dual-mass flywheel	NSK1000
---	---	---	---	250	24T/25.6	NF04	19.6	Includes NF04 flywheel	NSK1000FW
---	---	---	---	250	24T/25.6	NF05	19.6	Includes NF05 flywheel, NF05 flywheel only works with EXEDY clutch kits, DOES NOT include CSC hydraulic slave cylinder (BRG0163)	NSK1024FW
---	---	---	---	250	24T/25.6	NF05	19.6	Includes NF05 flywheel, NF05 flywheel only works with EXEDY clutch kits, DOES NOT include CSC hydraulic slave cylinder (BRG0163)	NSK1024FW
---	---	---	---	225	24T/25.6	---	---	---	06004
---	---	---	---	250	24T/25.6	---	---	Includes SE-R	NSK1002
---	---	---	---	240	24T/25.6	---	---	AWD, Turbo, Non US model	---
---	---	---	---	225	24T/25.6	---	---	---	06009
---	---	---	---	225	24T/25.6	---	---	Diesel	06034
---	---	---	---	240	24T/25.6	---	---	---	06044
---	---	---	---	250	24T/25.6	---	---	---	NSK1002
06902	270	203	154	215	18T/20.6	---	---	---	KNS02
---	---	---	---	240	24T/25.6	---	---	AWD, Turbo, Non US model	---
06902	270	203	154	215	18T/20.6	---	---	---	KNS02
---	---	---	---	240	24T/25.6	NF01	---	Push type, AWD, Turbo, Non US model	---
---	---	---	---	250	24T/25.6	---	---	Pull type, AWD, Turbo, Non US model	NSK1038
---	---	---	---	250	24T/25.6	---	---	Pull type, AWD, Turbo, Non US model	NSK1038
06901B	429	390	312	240	24T/25.6	NF02	13.9	5 Speed, Turbo, Non US model	---
06901B	429	390	312	240	24T/25.6	---	---	6 Speed, Turbo, Non US model	---
06900A	496	390	312	240	24T/25.6	---	---	AWD	06051
06900B	496	390	312	240	24T/25.6	---	---	2WD & AWD	06059
06900A	496	390	312	240	24T/25.6	---	---	---	06006
---	---	---	---	225	24T/25.6	---	---	2WD & 4WD	06004
06900A	496	390	312	240	24T/25.6	---	---	2WD & AWD	06006
---	---	---	---	225	24T/25.6	---	---	---	06034
06900A	496	390	312	240	24T/25.6	---	---	2WD & AWD	06006
06900A	496	390	312	240	24T/25.6	---	---	2WD & AWD	KNS03

Stage 1 - Stage 2 - Flywheels

Application	Engine Size	Year	Engine Code	Clamp Load	STAGE 1				STAGE 2 Thick Pad				
					Kit Part #	Clutch Torque	TQ@ Flywheel	TQ@ Wheels	Kit Part #	Clutch Torque	Flywheel TQ@	Wheels TQ@	
Oldsmobile													
Alero	2.3L/2.4L	95-99	LD2/LD9	1785	04800	349	277	222	---	---	---	---	---
Plymouth													
Laser	2.0L	90-4/92	4G63T	2136	05800	412	329	264	05950	479	381	305	---
Laser	2.0L	5/92-94	4G63T	2136	05800	412	329	264	05950	479	381	305	---
Laser	2.0L	92-4/92	4G63T	2136	05800	412	329	264	05950	479	381	305	---
Laser	2.0L	5/92-94	4G63T	2136	05800	412	329	264	05950	479	381	305	---
Laser	2.0L	90-94	4G63	1544	05801	283	225	180	05951	328	261	209	---
Pontiac													
Firebird, Trans-Am	5.7L	98-02	LS-1	3372	04805FW	820	622	498	04954FW	1014	640	533	---
G5	2.2L	07-09	---	1866	04801	364	290	232	04950	423	337	270	---
G5	2.4L	07-09	---	1866	04801	364	290	232	04950	423	337	270	---
Grand AM	2.3L/2.4L	95-99	LD2/LD9	1785	04800	349	277	222	---	---	---	---	---
GTO	5.7L/6.0L	04-06	LS-3	3372	04805FW	820	622	498	04954FW	1014	640	533	---
Solstice	2.4L	06-09	---	1866	04802	364	290	232	04951	423	337	270	---
Sunfire	2.3L/2.4L	95-99	LD2/LD9	1785	04800	349	277	222	---	---	---	---	---
Vibe	1.8L	03-06	1ZZ-FE/ 2ZZ-GE	1543	16800	283	225	180	16950	328	261	209	---
Saab													
9-2X	2.0L	05	---	2315	15802	454	361	289	15950	527	420	336	---
					---	---	---	---	15950P4	527	420	336	---
9-2X	2.0L	05	---	2563	15802HD	502	399	319	15950HD	583	463	371	---
					---	---	---	---	15950HDP4	583	463	371	---
9-2X	2.5L	05	---	1652	15801	319	254	203	---	---	---	---	---
9-2X	2.5L	06	---	2383	15804	472	376	301	15952	548	437	350	---
Saturn													
Sky	2.4L	07	---	1866	04802	364	290	232	04951	423	337	270	---
Scion													
xA	1.5L	03-06	1NZ-FE	1543	16800A	283	225	180	16950	328	261	209	---
xB	1.5L	03-06	1NZ-FE	1543	16800A	283	225	180	16950	328	261	209	---
xB	2.4L	08-15	2AZ-FE	2093	16803A	431	343	275	16953A	501	399	319	---
tC	2.4L	05-10	2AZ-FE	2093	16803A	431	343	275	16953A	501	399	319	---
FR-S	2.0L	13-16	D-4S	1349	15806	259	207	166	15955	311	248	199	---

STAGE 2 Thin Pad				Disc Size (mm)	Splines Teeth/ Major Dia (mm)	Light Weight Flywheel		Notes	Standard Clutch Kit Part #
Kit Part #	Clutch Torque	Flywheel TQ@	Wheels TQ@			Part #	Weight (lb)		
---	---	---	---	225	14T/25	---	---	---	KGM04
05900	435	347	278	225	20T/22.4	---	---	Turbo 2WD, 6 bolt crank	05048
05900	435	347	278	225	20T/22.4	---	---	Turbo 2WD, 7 bolt crank	05048
05900	435	347	278	225	20T/22.4	MF03	12.0	Turbo AWD, 6 bolt crank	05048
05900	435	347	278	225	20T/22.4	MF01	12.0	Turbo AWD, 7 bolt crank	05048
---	---	---	---	215	20T/22.4	---	---	Non-Turbo	05051
---	---	---	---	290	26T/29	GF502A	18.0	Cushion button type Stage 2 Disc, 6 Speed, Must change flywheel to GF502A when using performance clutch kit (#04805FW, #04954FW), Includes flywheel	04173
---	---	---	---	225	14T/25	GF501	10.5	Natural aspirated, Does not include CSC hydraulic slave cylinder (BRG0143)	GMK1010
---	---	---	---	225	14T/25	GF501	10.5	Natural aspirated, Does not include CSC hydraulic slave cylinder (BRG0143)	GMK1010
---	---	---	---	225	14T/25	---	---	---	04162
---	---	---	---	290	26T/29	GF502A	18.0	Cushion button type Stage 2 Disc, 6 Speed, Must change flywheel to GF502A when using performance clutch kit (#04805FW, #04954FW), Includes flywheel	04173
---	---	---	---	225	26T/29	GF501	10.5	Natural aspirated, Does not include CSC hydraulic slave cylinder	GMK1032
---	---	---	---	225	14T/25	---	---	---	04158
---	---	---	---	215	21T/24.1	---	---	5 Speed, 6 Speed	KTY03/ TYK1500
15900	527	420	336	230	24T/25.2	FF01	12.7	Aero, Turbo, Pull type	KSB03
---	---	---	---	230	24T/25.2	FF01	12.7	4 Puck design disc, Aero, Turbo, Pull type	KSB03
---	---	---	---	230	24T/25.2	FF01	12.7	Aero, Turbo, Pull Type	KSB03
---	---	---	---	230	24T/25.2	FF01	12.7	4 Puck design disc, Aero, Turbo, Pull type	KSB03
---	---	---	---	225	24T/25.2	FF02	12.7	Linear, Non-Turbo, SOHC	KSB04
---	---	---	---	230	24T/25.2	FF502A	12.7	Aero, Turbo, Push type	FJK1001
---	---	---	---	225	26T/29	---	---	Natural aspirated, Does not include CSC hydraulic slave cylinder	---
---	---	---	---	215	21T/24.1	---	---	---	KTY15
---	---	---	---	215	21T/24.1	---	---	---	KTY15
---	---	---	---	240	21T/29.8	---	---	---	TYK1506
---	---	---	---	240	21T/29.8	---	---	---	TYK1506
---	---	---	---	230	24T/25.2	TF02	12.7	---	FJK1005

Stage 1 - Stage 2 - Flywheels

Application	Engine Size	Year	Engine Code	Clamp Load	STAGE 1				STAGE 2 Thick Pad			
					Kit Part #	Clutch Torque	TQ@ Flywheel	TQ@ Wheels	Kit Part #	Clutch Torque	TQ@ Flywheel	TQ@ Wheels
Subaru												
BAJA	2.5L	03-05	EJ25	1652	15801	319	254	203	15954	399	300	228
BAJA	2.5L	04-05	EJ25T	2315	15802	454	361	289	15950	527	420	336
					---	---	---	---	15950P4	527	420	336
BAJA	2.5L	04-05	EJ25T	2563	15802HD	502	399	319	15950HD	583	463	371
					---	---	---	---	15950HDP4	583	463	371
BRZ	2.0L	13-19	FA20	1349	15806	259	207	166	15955	311	248	199
Forester	2.5L	98-13	EJ25	1652	15801	319	254	203	15954	399	300	228
Forester	2.5L	04-05	EJ25T	2315	15802	454	361	289	15950	527	420	336
					---	---	---	---	15950P4	527	420	336
Forester	2.5L	04-05	EJ25T	2563	15802HD	502	399	319	15950HD	583	463	371
					---	---	---	---	15950HDP4	583	463	371
Forester	2.5L	06-11	EJ25T	2383	15804	472	376	301	15952	548	437	350
Impreza	2.0L	12-16	FB20	1652	15801	319	254	203	15954	399	300	228
Impreza	2.5L	97-11	EJ25	1652	15801	319	254	203	15954	399	300	228
Impreza WRX	2.0L	02-05	EJ20T	2315	15802	454	361	289	15950	527	420	336
					---	---	---	---	15950P4	527	420	336
Impreza WRX	2.0L	02-05	EJ20T	2563	15802HD	502	399	319	15950HD	583	463	371
					---	---	---	---	15950HDP4	583	463	371
Impreza WRX	2.5L	06-14	EJ25T	2383	15804	472	376	301	15952	548	437	350
Impreza WRX	2.0L	15-17	FA20DIT	2383	15804	472	376	301	15952	548	437	350
Impreza WRX STI	2.5L	04-19	EJ25T	2536	15803	522	415	332	15951	607	482	386
					---	---	---	---	15951P4	607	482	386
Impreza WRX STI	2.5L	04-19	EJ25T	3597	15803HD	741	590	472	15951HD	860	685	548
					---	---	---	---	15951HDP4	860	685	548
Legacy	2.2L	91-94	EJ22T	2315	15802	454	361	289	15950	527	420	336
					---	---	---	---	15950P4	527	420	336
Legacy	2.2L	91-94	EJ22T	2563	15802HD	502	399	319	15950HD	583	463	371
					---	---	---	---	15950HDP4	583	463	371
Legacy	2.5L	96-09	EJ25	1652	15801	319	254	203	15954	399	300	228
Legacy GT	2.5L	05-06	EJ25T	2383	15804	472	376	301	15952	548	437	350
Legacy GT	2.5L	07-12	EJ25T	2383	15804	472	376	301	15952	548	437	350
Legacy GT Spec B	2.5L	07-09	EJ25T	2536	15803	522	415	332	15951	607	482	386
					---	---	---	---	15951P4	607	482	386

STAGE 2 Thin Pad				Disc Size (mm)	Splines Teeth/ Major Dia (mm)	Light Weight Flywheel		Notes	Standard Clutch Kit Part #
Kit Part #	Clutch Torque	TQ@ Flywheel	TQ@ Wheels			Part #	Weight (lb)		
---	---	---	---	225	24T/25.2	FF02	12.7	Non-Turbo, SOHC, Stage 2 is Cushion button type disc	KSB04
15900	527	420	336	230	24T/25.2	FF01	12.7	Turbo, DOHC, Pull type	KSB03
---	---	---	---	230	24T/25.2	FF01	12.7	4 Puck design disc, Turbo, DOHC, Pull type	KSB03
---	---	---	---	230	24T/25.2	FF01	12.7	Turbo, DOHC, Pull type	KSB03
---	---	---	---	230	24T/25.2	FF01	12.7	4 Puck design disc, Turbo, DOHC, Pull type	KSB03
---	---	---	---	230	24T/25.2	TF02	12.7	---	FJK1005
---	---	---	---	225	24T/25.2	FF02	12.7	Non-Turbo, SOHC, Stage 2 is Cushion button type disc	KSB04
15900	527	420	336	230	24T/25.2	FF01	12.7	Turbo, DOHC, Pull type	KSB03
---	---	---	---	230	24T/25.2	FF01	12.7	4 Puck design disc, Turbo, DOHC, Pull type	KSB03
---	---	---	---	230	24T/25.2	FF01	12.7	Turbo, DOHC, Pull type	KSB03
---	---	---	---	230	24T/25.2	FF01	12.7	4 Puck design disc, Turbo, DOHC, Pull type	KSB03
---	---	---	---	230	24T/25.2	FF502A	12.7	Turbo, Push type, Must change flywheel to FF502A for performance clutch kit (#15804, #15952)	FJK1001
---	---	---	---	225	24T/25.2	FF02	12.7	Non-Turbo, Stage 2 is Cushion button type disc	KSB04
---	---	---	---	225	24T/25.2	FF02	12.7	Non-Turbo, SOHC, Stage 2 is Cushion button type disc	KSB04
15900	527	420	336	230	24T/25.2	FF01	12.7	Turbo, Pull type, (GC8, GF8, GDA)	KSB03
---	---	---	---	230	24T/25.2	FF01	12.7	4 Puck design disc, Turbo, Pull type, (GC8, GF8, GDA)	KSB03
---	---	---	---	230	24T/25.2	FF01	12.7	Turbo, Pull type, (GC8, GF8, GDA)	KSB03
---	---	---	---	230	24T/25.2	FF01	12.7	4 Puck design disc, Turbo, Pull type, (GC8, GF8, GDA)	KSB03
---	---	---	---	230	24T/25.2	FF502A	12.7	Turbo, Push type	FJK1001
---	---	---	---	230	24T/25.2	FF502A	12.7	Turbo, Push type	FJK1001
---	---	---	---	240	24T/25.2	FF501A	13.3	Turbo, Pull Type, US model	FJK1000
---	---	---	---	240	24T/25.2	FF501A	13.3	4 Puck design disc, Turbo, Pull type, US model	FJK1000
---	---	---	---	240	24T/25.2	FF501A	13.3	Turbo, Pull Type, US model	FJK1000
---	---	---	---	240	24T/25.2	FF501A	13.3	4 Puck design disc, Turbo, Pull type, US model	FJK1000
15900	527	420	336	230	24T/25.2	FF01	12.7	Turbo, DOHC, Pull type	KSB01
---	---	---	---	230	24T/25.2	FF01	12.7	4 Puck design disc, Turbo, DOHC, Pull type	KSB01
---	---	---	---	230	24T/25.2	FF01	12.7	Turbo, DOHC, Pull type	KSB01
---	---	---	---	230	24T/25.2	FF01	12.7	4 Puck design disc, Turbo, DOHC, Pull type	KSB01
---	---	---	---	225	24T/25.2	FF02	12.7	Non-Turbo, SOHC, Stage 2 is Cushion button type disc	KSB04
---	---	---	---	230	24T/25.2	FF502A	12.7	Turbo, Push Type, Must change flywheel to FF502A for performance clutch kit (#15804, #15952)	FJK1001FW
---	---	---	---	230	24T/25.2	FF502A	12.7	Turbo, Push type	FJK1001
---	---	---	---	240	24T/25.2	FF501A	13.3	6 Speed Transmission, Spec B, Must use FF501A	FJK1002
---	---	---	---	240	24T/25.2	FF501A	13.3	4 Puck design disc, 6 Speed transmission, Spec B, Must use FF501A	FJK1002

Stage 1 - Stage 2 - Flywheels

Application	Engine Size	Year	Engine Code	Clamp Load	STAGE 1				STAGE 2 Thick Pad			
					Kit Part #	Torque Clutch	TQ@ Flywheel	TQ@ Wheels	Kit Part #	Torque Clutch	TQ@ Flywheel	TQ@ Wheels
Subaru continued												
Legacy GT Spec B	2.5L	07-09	EJ25T	3597	15803HD	741	590	472	15951HD	860	685	548
					---	---	---	---	15951HDP4	860	685	548
Legacy	3.0L	05	EZ30D	1652	15801	319	254	203	15954	399	300	228
Outback XT	2.5L	05-06	EJ25T	2383	15804	472	376	301	15952	548	437	350
Outback XT	2.5L	07-09	EJ25T	2383	15804	472	376	301	15952	548	437	350
XV Crosstrek	2.0L	13-17	FB20	1652	15801	319	254	203	15954	399	300	228
Toyota												
Camry	2.5L	88-91	2VZF	2093	16803A	431	343	275	16953A	501	399	319
Camry	3.0L	92-01	3VZ/1MZFE	2093	16803A	431	343	275	16953A	501	399	319
Celica	1.8L	94-00	7A-FE/1ZZ-FE	1543	16800	283	225	180	16950	328	261	209
Celica	2.0L	88-89	3S-GTE	2093	16803C	431	343	275	16953C	501	399	319
Celica	2.0L	90-94	3S-GTE	2093	16803A	431	343	275	16953A	501	399	319
Celica GT-S	1.8L	00-05	1ZZ-FE/2ZZ-GE	1543	16800	283	225	180	16950	328	261	209
Corolla	1.6L	80-82	3TC	1212	16804A	212	169	133	16954A	246	196	157
Corolla	1.6L	8/83-87	4ALC	1212	16804A	212	169	133	16954A	246	196	157
Corolla	1.6L	8/83-89	4ALC	1212	16804B	212	169	133	16954B	246	196	157
Corolla GT-S	1.6L	85-87	4AGE	1212	16804A	212	169	133	16954A	246	196	157
Corolla GT-S	1.6L	88-7/89	4AGE	1212	16804B	212	169	133	16954B	246	196	157
Corolla GT-S	1.6L	8/89-92	4AGE	1543	16800	283	225	180	16950	328	261	209
Corolla	1.6L	89-4/91	4AFE	1212	16804B	212	169	133	16954B	246	196	157
Corolla	1.6L	5/91-8/92	4AFE	1212	16804C	212	169	133	16954C	246	196	157
Corolla FX	1.6L	9/86-8/88	4AGELC	1212	16804B	212	169	133	16954B	246	196	157
Corolla FX	1.6L	2/87-8/88	4ALC	1212	16804B	212	169	133	16954B	246	196	157
Corolla	1.8L	93-04	7A-FE	1543	16800	283	225	180	16950	328	261	209
ECHO	1.5L	00-05	1NZ-FE	1543	16800A	283	225	180	16950A	328	261	209
GT86	2.0L	13-17	4U-GSE	1349	15806	259	207	166	15955	311	248	199
Matrix	1.8L	03-07	1ZZ-FE/ 2ZZ-GE	1543	16800	283	225	180	16950	328	261	209
MR-2	1.6L	85	4AGELC	1212	16804B	212	169	133	16954B	246	196	157
MR-2	1.6L	86-89	4AGE	1543	16800	283	225	180	16950	328	261	209
MR-2	1.6L SC	88-89	4AGZ	1549	16802	299	238	191	16952	347	277	222
MR-2	2.0L	90-95	3S-GTE	2093	16803A	431	343	275	16953A	501	399	319
MR-2 Spyder	1.8L	00-05	1ZZ-FE	1543	16800	283	225	180	16950	328	261	209

STAGE 2 Thin Pad				Disc Size (mm)	Spline Teeth/ Major Dia (mm)	Light Weight Flywheel		Notes	Standard Clutch Kit Part #
Kit Part #	Clutch Torque	TA@ Flywheel	TA@ Wheels			Part #	Weight (lb)		
---	---	---	---	240	24T/25.2	FF501A	13.3	6 Speed transmission, Spec B, Must use FF501A flywheel	FJK1002
---	---	---	---	240	24T/25.2	FF501A	13.3	4 Puck design disc, 6 Speed transmission, Spec B, Must use FF501A flywheel	FJK1002
---	---	---	---	225	24T/25.2	FF02	12.7	Non-Turbo, DOHC, Stage 2 is Cushion button type disc	KSB04
---	---	---	---	230	24T / 25.2	FF502A	12.7	Turbo, Push type, Must use FF502A flywheel	FJK1001FW
---	---	---	---	230	24T / 25.2	FF502A	12.7	Turbo, Push type, 5 Speed	FJK1001FW
---	---	---	---	225	24T / 25.2	FF02	12.7	5 Speed, Stage 2 is Cushion button type disc	KSB04
---	---	---	---	240	21T/29.8	---	---	---	16082
---	---	---	---	240	21T/29.8	---	---	---	16082
---	---	---	---	215	21T/24.1	---	---	---	KTY18
---	---	---	---	240	21T/29.8	---	---	Turbo	16062
---	---	---	---	240	21T/29.8	---	---	Turbo	KTY11
---	---	---	---	215	21T/24.1	---	---	VVLT-I	KTY14
---	---	---	---	200	21T/24.1	---	---	4 Door 4 Speed & All w/5 Speed	16070
---	---	---	---	200	21T/24.1	---	---	RWD, Except GTS	16070
---	---	---	---	200	21T/24.1	---	---	FWD, Except GTS	16042
---	---	---	---	200	21T/24.1	---	---	---	16070
---	---	---	---	200	21T/24.1	---	---	---	16070
---	---	---	---	215	21T/24.1	TF01	10.8	---	16074
---	---	---	---	200	21T/24.1	---	---	FWD, Except GTS	16070
---	---	---	---	200	21T/24.1	---	---	FWD, 2WD, Except GTS	16070
---	---	---	---	200	21T/24.1	---	---	FX16	KTY06
---	---	---	---	200	21T/24.1	---	---	---	16042
---	---	---	---	215	21T/24.1	---	---	---	KTY18
---	---	---	---	215	21T/24.1	---	---	---	KTY15
---	---	---	---	230	24T/25.2	TF02	12.7	---	FJK1005
---	---	---	---	215	21T/24.1	---	---	5 Speed, 6 Speed	KTY03/ TYK1500
---	---	---	---	200	21T/24.1	---	---	---	16029
---	---	---	---	215	21T/24.1	TF01	10.8	---	16074
---	---	---	---	225	21T/29.8	---	---	Supercharged	16075
---	---	---	---	240	21T/29.8	---	---	Turbo	16062
---	---	---	---	215	21T/24.1	---	---	---	KTY03

Stage 1 - Stage 2 - Flywheels

Application	Engine Size	Year	Engine Code	Clamp Load	STAGE 1				STAGE 2 Thick Pad				
					Kit Part #	Clutch Torque	TQ@ Flywheel	TQ@ Wheels	Kit Part #	Clutch Torque	TQ@ Flywheel	TQ@ Wheels	
Toyota continued													
Paseo	1.5L	92-99	5E-FE	1212	16804B	212	169	133	16954B	246	196	157	
Supra	2.6L	79-80	4ME	1753	16801B	339	270	216	16951B	393	313	251	
Supra	2.8L	81	5ME	1753	16801B	339	270	216	16951B	393	313	251	
Tercel	1.5L	91-94	3E-E	1212	16804B	212	169	133	16954B	246	196	157	
Tercel	1.5L	95-98	5E-FE	1212	16804B	212	169	133	16954B	246	196	157	
Yaris	1.5L	06	1NZ-FE	1543	16800A	283	225	180	16950A	328	261	209	
Toyota Truck													
4-Runner	2.4L	85-87	22REC	1753	16801B	339	270	216	16951B	393	313	251	
4-Runner	2.4L	89-92	22RE/22REC	1753	16801A	339	270	216	16951A	393	313	251	
4-Runner	2.4L	93-95	22RE/22REC	1753	16801A	339	270	216	16951A	393	313	251	
4-Runner	2.7L	96-00	3RZ-FE	1985	16806A	420	326	272	16956A	502	371	309	
4-Runner	3.0L	88-95	3VZE	1852	16803B	369	294	235	16953B	441	399	319	
4-Runner	3.4L	96-02	5VZ-FE	1985	16805	420	326	272	---	---	---	---	
FJ Cruiser	4.0L	07-14	1GR-FE	2068	---	---	---	---	16957	563	450	360	
Pick-Up	2.4L	81-88	22R/22REC	1753	16801B	339	270	216	16951B	393	313	251	
Pick-Up	2.4L	89-92	22R/22RE	1753	16801A	339	270	216	16951A	393	313	251	
Pick-Up	2.4L	93-95	22R/22RE	1753	16801A	339	270	216	16951A	393	313	251	
T100	2.7L	94-98	3RZ-FE	1985	16806A	420	326	272	16956A	502	371	309	
T100	3.0L	93-94	3VZE	1852	16803B	369	294	235	16953B	441	399	319	
T100	3.0L	93-94	3VZE	1985	16806B	420	326	272	16956B	502	371	309	
T100	3.4L	95-98	5VZ-FE	1985	16805	420	326	272	---	---	---	---	
Tacoma	2.4L	01-04	2RZ-FE	1985	16806A	420	326	272	16956A	502	371	309	
Tacoma	2.7L	95-04	3RZ-FE	1985	16806A	420	326	272	16956A	502	371	309	
Tacoma	3.4L	95-04	5VZ-FE	1985	16805	420	326	272	---	---	---	---	
Tacoma	4.0L	05-11	1GR-FE	2068	---	---	---	---	16957A	563	450	360	
Tundra	3.4L	00-04	5VZ-FE	1985	16805	420	326	272	---	---	---	---	
Tundra	4.0L	05-06	1GR-FE	2068	---	---	---	---	16957	563	450	360	
Volkswagen													
Corrado	2.8L	92-95	---	2091	17800	404	321	257	17950	474	377	302	
Golf/Golf III/ GTI	2.8L	95-02	AAA/AFP	2091	17800	404	321	257	17950	474	377	302	
Jetta/ Jetta III	2.8L	94-02	AAA/AFP	2091	17800	404	321	257	17950	474	377	302	
Passat	2.8L	93-97	AAA	2091	17800	404	321	257	17950	474	377	302	

STAGE 2 Thin Pad				Disc Size (mm)	Splines Teeth/ Major Dia (mm)	Light Weight Flywheel		Notes	Standard Clutch Kit Part #
Kit Part #	Clutch Torque	Flywheel TQ@	Wheels TQ@			Part #	Weight (lb)		
---	---	---	---	200	21T/24.1	---	---	---	16029
---	---	---	---	225	21T/29.8	---	---	---	16016
---	---	---	---	225	21T/29.8	---	---	---	16016
---	---	---	---	200	21T/24.1	---	---	4 Speed Only	16070
---	---	---	---	200	21T/24.1	---	---	---	16070
---	---	---	---	215	21T/24.1	---	---	---	---
---	---	---	---	225	21T/29.8	---	---	Non-Turbo	16057
---	---	---	---	225	21T/29.8	---	---	2WD & 4WD	16058
---	---	---	---	225	21T/29.8	---	---	2WD	16058
---	---	---	---	250	21T/29.8	---	---	---	16090
---	---	---	---	240	21T/29.8	---	---	2WD & 4WD	16059
---	---	---	---	250	21T/29.8	---	---	---	16087
---	---	---	---	275	21T/29.8	---	---	---	TYK1503
---	---	---	---	225	21T/29.8	---	---	Non-Turbo	16057
---	---	---	---	225	21T/29.8	---	---	2WD & 4WD	16058
---	---	---	---	225	21T/29.8	---	---	2WD	16058
---	---	---	---	250	21T/29.8	---	---	---	16090
---	---	---	---	250	21T/29.8	---	---	2WD	16059
---	---	---	---	250	21T/29.8	---	---	4WD	KTY16
---	---	---	---	250	21T/29.8	---	---	---	16087
---	---	---	---	250	21T/29.8	---	---	4WD	16090
---	---	---	---	250	21T/29.8	---	---	---	16090
---	---	---	---	250	21T/29.8	---	---	---	16087
---	---	---	---	275	21T/29.8	---	---	---	TYK1515
---	---	---	---	250	21T/29.8	---	---	---	16087
---	---	---	---	275	21T/29.8	---	---	---	TYK1503
---	---	---	---	228	28T/22.2	---	---	VR6, 5 Speed	17036
---	---	---	---	228	28T/22.2	---	---	VR6, 5 Speed	17036
---	---	---	---	228	28T/22.2	---	---	VR6, 5 Speed	17036
---	---	---	---	228	28T/22.2	---	---	VR6, 5 Speed	17036

Stage 3

HYPER *Single*

The Hyper Single Clutch is engineered to optimize the performance of cars that are moderately modified, but do not require the clutch capacity of a multi-plate clutch. Similar to our multi-plate clutches, it has a purple anodized, forged aluminum cover. The aluminum cover is stiffer than a stamped cover and therefore allows a higher lever ratio to maintain the pedal efforts at a reasonable level. There is no clamp load deflection as found in a pressed metal type cover.

All Hyper Single clutches come with a chromoly steel flywheel, 6-puck cerametallic facing and a spring center damper disc assembly. The disc is generally smaller and thinner than the OEM disc making for lower inertia and therefore quicker, easier shifting and less wear and tear on the transmission synchros. The higher clamp load and cerametallic friction facings give approximately twice the holding torque of the OEM clutch and generally higher than other single plate clutches. An additional feature of the pressure plate is a series of turbine-like, air flow enhancing vanes that keep the clutch cooler under extreme operating conditions to improve wear life.

- High friction coefficient, low wear, and a special heat resistant material (T5001) has been developed enabling clutch size to be reduced and increased durability to be achieved.
- Durability is improved with the use of a stronger, smaller damper disc, specifically redesigned for the Hyper Single Clutch.
- A lower level of inertia is achieved over the genuine fitment clutch which improves shift response for faster gear changes particularly for racing applications.



Pull Type Clutch

The pull type clutch accommodates higher torque, in conjunction with lighter pedal efforts to produce a superior clutch operation, when adapted to most high-powered vehicles. An EXEDY Original design.

Advantages

- Unlike the push type cover, when a pull type cover flexes, it will flex in the direction of disengagement, assisting in positive pedal feel.
- A longer lever ratio achieves a direct decrease in pedal effort.

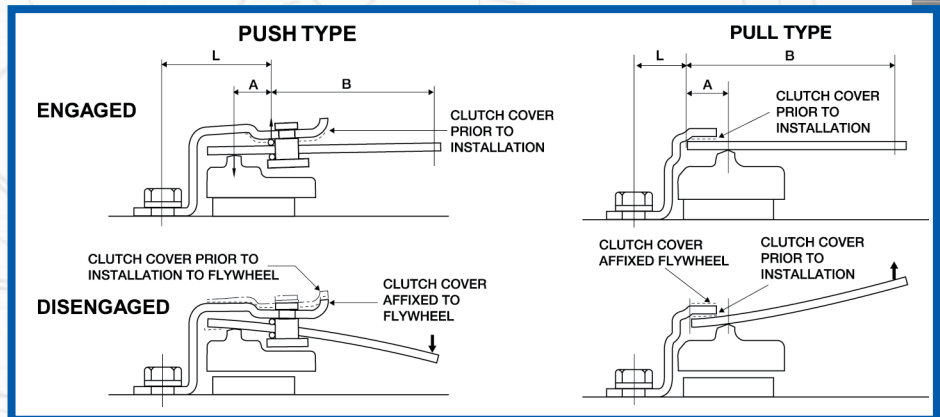

Patented One Touch Snap in Function

The problem of detachment difficulties is solved by the use of EXEDY original one-touch snap in bearing design. Detachment can easily be accomplished with the use of a screwdriver, alternatively, the bearing can be snapped back into place while activating the release fork.

What is Inertia?

Inertia is the tendency of the clutch and flywheel to maintain rotation even when not connected to the engine torque. This affects the responsiveness of the engine and also the feel of low rpm torque and start up driveability.

In the case of the clutch disc, lower inertia is always better to improve shift efforts and reduce the wear on the transmission synchros.



Stage 4 & 5

HYPER *Multi Plate*

Twin and Triple Plate

For high-powered applications, EXEDY offers twin and triple Multi-Plate Clutches. These are designed for high power street action as well as drag, road and rally racing.

The twin plate clutches are rated for approximately 500 ft.lbs. TQ @ FW. The triple plate clutches are rated for up to and over 800 ft.lbs. TQ @ FW. Twins come with both spring damper discs or solid discs depending on application. Triples are all solid discs and not recommended for street use.

All of our multi-plate clutches come with a lightweight, chromoly steel flywheel and the famous purple anodized forged aluminum clutch cover. Depending on the application, we have both strap drive and lug drive models. All have T5001 cerametallic friction materials for extreme heat resistance.

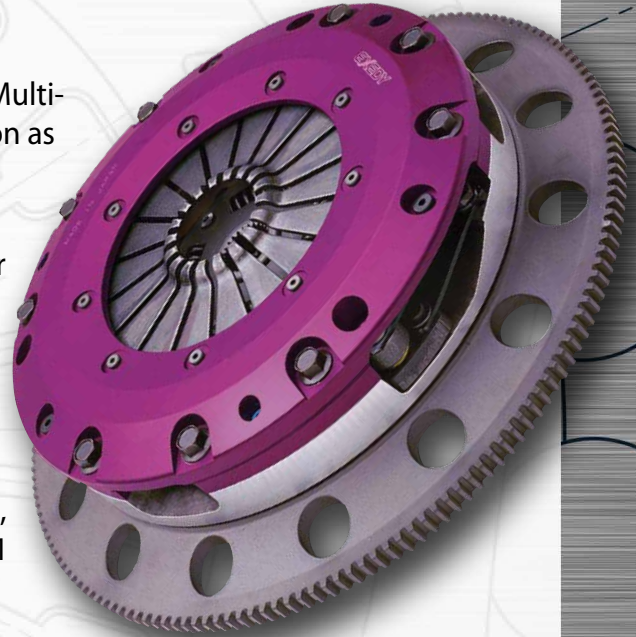

SD Type

This model has been developed for high powered street cars and race cars with up to approximately 600TQ @ FW. They feature ventilated, thick intermediate plates for improved life and spring damper discs to protect your transmission and drive line.

600TQ @ FW. The combination of ultra lightweight solid discs and a lightweight chromoly flywheel gives the driver a lightened pedal effort and quick response. This can improve your times when running at the drag strip or road course. They feature ventilated, thick intermediate plates for improved life.

SR Type

This model has twin or triple plates developed to be lightweight for quick response. The Triple plate model is available for over 800TQ @ FW and the twin plate model is rated to approximately

HR Type

This model has three plates and is developed specifically for high power applications such as over 800TQ @ FW for drag racing. It handles high torque loads and shifts smooth, and because of the lightweight clutch discs, you can reduce your shift times.

Patented Clutch Cushioning Function

The “cushion” function is a new innovation unique to EXEDY. The half engaged “zone” is expanded as a result of a decrease in rigidity of the pivot ring. Ideal pedal effort is achieved as a result of a longer lever ratio of the diaphragm spring coupled with the cushion reaction force.

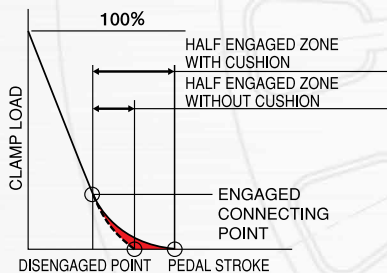
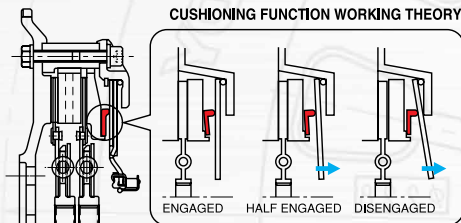

Engine Modifications

Cam, timing, turbo modifications etc., cause engine pulsation and vibrations. These vibrations can cause clutch rattle when the clutch pedal is depressed by movement on the intermediate separator plate, in some applications. These noises will in no way affect the performance of the EXEDY Multi Plate Clutch. This rattle is well accepted in the performance industry where engine modifications have been carried out.

Patented Center Plate Self Leveling Function

The amount of center plate travel during release is always maintained in a neutral position by the reaction force of the lifting plate attached to both sides of the center plate.

- Improved disengagement (accelerated separation from friction surface).
- Improved disc life by eliminating unbalanced wear at the T/M and F/W side.
- Prevents and lowers mechanical noise.

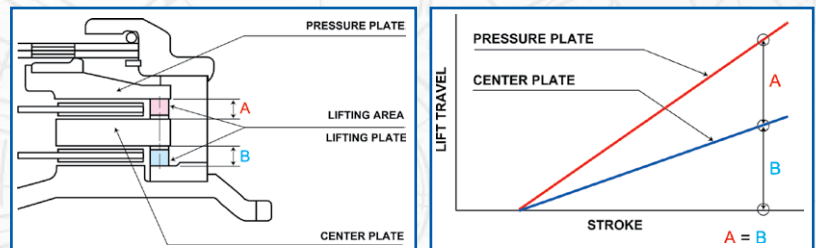

Working Theory

Due to high temperatures generated by the clutch system during operation, the pressure plate tends to absorb a large portion of that heat, accelerating the wear of the pressure plate side disc. The Lifting plate location remains steady between the location area on the pressure plate shown as (A) and F/W location area shown as (B) on the chart above. Accordingly, the wear of the pressure plate side disc is accelerated, resulting in the F/W side disc automatically being engaged earlier than the pressure plate side, which in turn increases the F/W side disc’s work and wear rate. Therefore, due to an increase in workload during half engaged operations, wear on the F/W side disc will be accelerated causing a reduction in the overall friction material thickness, resulting in the F/W disc registering a similar thickness friction material to that on the pressure plate side.

HYPET

Carbon Series

The flagship model of EXEDY clutches, the Carbon Steel Multi Plate Clutch. These Clutches are lightweight, durable and resilient to high heat, contributing to an improvement in track times.

Warm Up Procedure

Due to the inherent properties of the carbon material, we must specify the proper way to bring the discs up to operating temperature.

This Process will heat the discs so they will hold the specified torque rating. The correct method is three, five second "slips" of the clutch within 30 seconds at low RPM.

High Heat Resistance

Carbon materials are baked at more than 3600°F, which allows the carbon material to dissipate heat far better than conventional metallic material. Heat expansion rate is 1/20th of iron therefore eliminating a change in clutch feel that may happen due to distortion caused by expansion during driving. Carbon material not only has a high heat resistance but also a "non-stick" characteristic that eliminates disengagement problems.

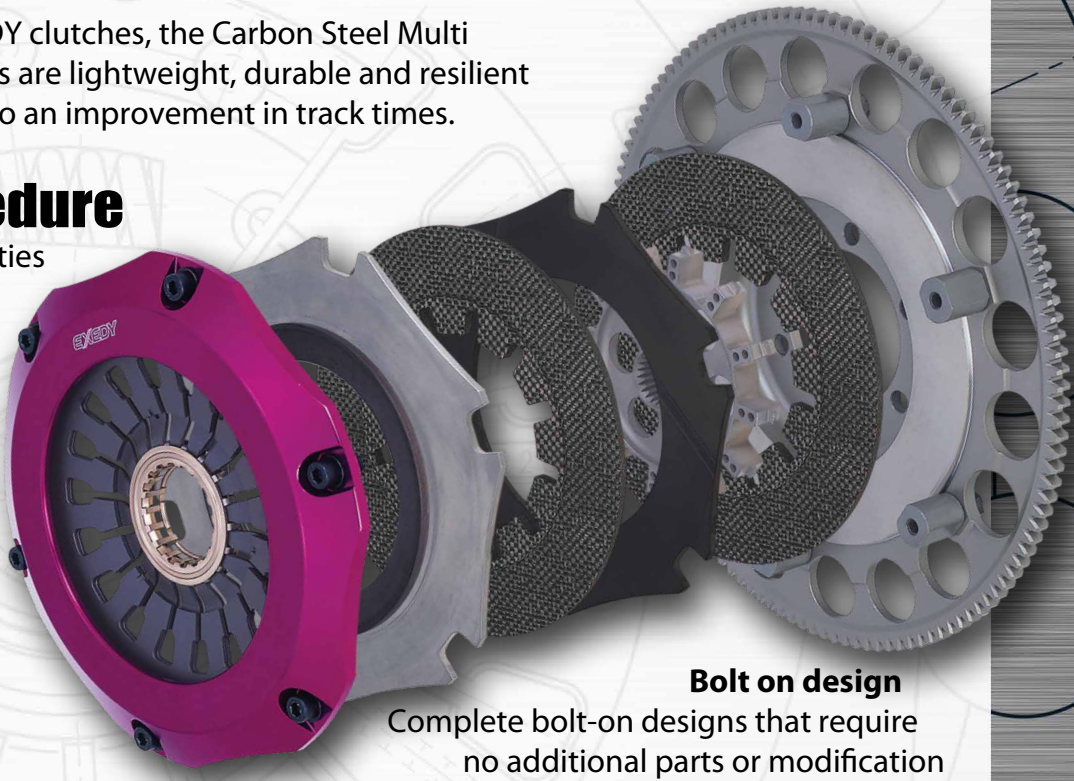

Bolt on design
Complete bolt-on designs that require no additional parts or modification



Light in Weight

The heaviest components of the clutch system are the clutch cover, intermediate plates and flywheel. Semi-Carbon clutches incorporate an improved cover configuration and lightened flywheel also contributing to a reduction in vehicle rotating weight.

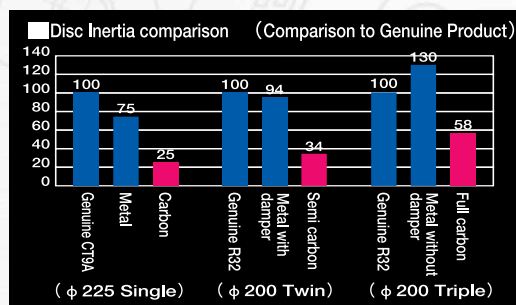

Low Inertia Design

The weight of a carbon clutch disc is one third that of a metallic disc. Utilizing a high friction coefficient Hyper Carbon disc which allows for quicker shift response. Low inertia discs allow the transmission to synchronize in a shorter space of time eliminating time loss during shift changing while also reducing the applied load to the synchronizer.

Easy to Handle

By controlling the carbon fibers and baking temperature, the cross layer type carbon material, which is the most appropriate for high revolution strength and high torque transmission, is applied to tuning car clutches. Semi-carbon clutches offer lightweight, high heat resistance and a stable friction coefficient.

EXEDY Carbon clutches are tuned so that at a lower temperature, engagement feeling is improved and conversely at high temperatures, engagement is ideal for spirited driving.

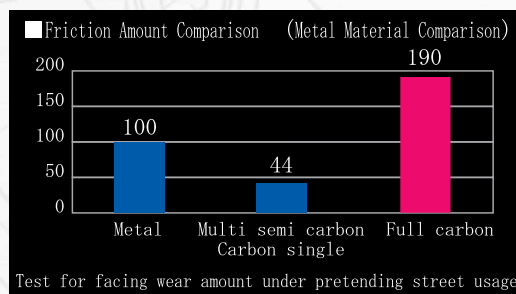
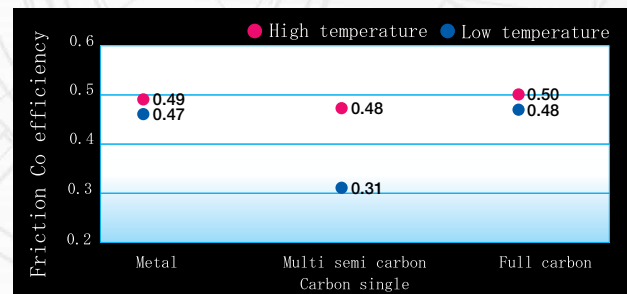

Long Life

Semi-Carbon clutches allow double the life when compared to conventional metallic type material, which equates to an improved cost performance thanks to longer overhaul cycles. Full carbon clutches have more wear than metallic however, when used with over-sized pressure plates, the life is identical to metallic.

HYPER *Carbon Series-D*

Introducing the Next Generation ...

...of clutch systems by EXEDY – Carbon-D,
the revolutionary Carbon Clutch System.

Carbon-D was developed to achieve the ultimate goal of comfort and streetability by absorbing noise and vibration emitted from drivetrain components such as the differential, transmission and engine. The Carbon-D system is designed to protect the drivetrain by absorbing and dissipating “shock torque” by utilizing EXEDY Patented Technology. Superior engineering enables the Carbon-D clutch system to possess an ideal clutch engagement position, increased clamp loads and lower pedal effort, while the unique Carbon Fiber friction material allows comfortable half-engaged clutch operation and responsive gear changes.

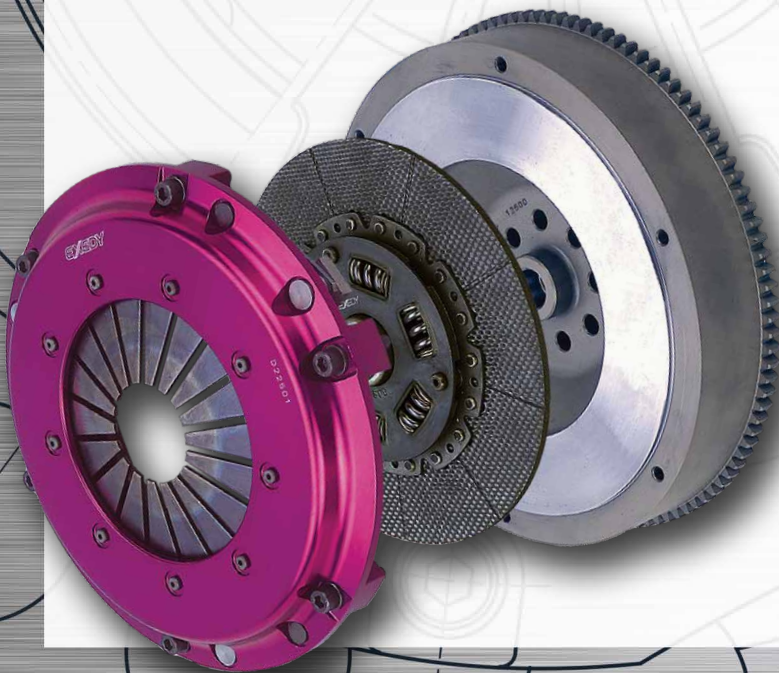

Carbon-D Single

- Introduction of a damper to absorb and dissipate noise and vibration
 - High clamp load, lower pedal effort and ideal clutch engagement is obtained with the use of the re-engineered diaphragm spring
 - Quiet Strap Drive design to minimize mechanical noise
- Patent Pending Disc System

Carbon-D Twin

- Introduction of a damper to absorb and dissipate noise and vibration
- With a reduction in pedal effort and an increase in disc size to 225mm, the Carbon-D Twin clutch is ideally suited to high performance street vehicles
- By optimizing the weight and inertia of the Carbon-D Clutch System, driveability is improved at low speeds



Gear Noise and Fluctuations in Engine Rotation (rpm)

Even engines that seem to run very smoothly always have some amount of fluctuation in engine rotation. These fluctuations, when transferred from the engine to the transmission, cause gear teeth carrying no torque to strike mating teeth, resulting in noise (“tooth hammer”). The noise is louder in the interior as well as outside the vehicle because the clutch housing acts as a speaker and magnifies the noise. Although the noise level and noise-generating speed depend on the type and model of car, such noise is more frequent in a 6-speed vehicle than in a 5-speed vehicle.

Vibration-Absorbing Damper

The conventional damper used in most sports clutches is designed to protect the transmission from shock torque caused by abrupt clutch engagement, so it does little to absorb vibration. Efficient absorption of fluctuations in engine speed requires a very flexible spring and proper setting of the hysteresis torque. The flexibility of the spring, however, is likely to run counter to the damper capacity. For this reason, Carbon-D is equipped with a new dual stage damper, a low-load stage and rapid-acceleration stage, both of which are perfectly tuned for each car type. This tuning technology is available only from EXEDY, the specialist in high performance clutch systems.

Stage 3 - Stage 4 - Stage 5

Stage 3 - Single Cerametallic ■ Single Carbon ■ Stage 4 - Twin Cerametallic ■ Twin Carbon ■ Twin Organic ■ Stage 5 - Triple Cerametallic ■ Triple Carbon ■

Application	Liter	Year	Engine	Clamp Load	Part #	Number of Disc	Disc Material	Sprung Center (D-core)	Clutch Torque	
Acura										
Integra	1.8L	90-91	B18A1	2023	HH06SD	SINGLE	CERA	YES	422	
					HM042SR	TWIN	CERA	NO	767	
Integra	1.7/1.8L	92-93	B17A/B18A	2203	HH02SBMC1	SINGLE	CARBON	NO	422	
					HH02SD	SINGLE	CERA	YES	422	
					HM022SR	TWIN	CERA	NO	767	
Integra	1.8L	94-01	B18B/B18C	2203	HH02SBMC1	SINGLE	CARBON	NO	422	
					HH02SD	SINGLE	CERA	YES	422	
					HM022SR	TWIN	CERA	NO	767	
NSX	3.0L	91-96	C30A1	2922	HH04SD1	SINGLE	CERA	YES	647	
					2653	HH04SDMC	SINGLE	CARBON	YES	559
					2630	HM012SBMC1	TWIN	CARBON	NO	1009
					1765	HMG12SD	TWIN	ORGANIC	YES	596
NSX	3.2L	97-05	C32B1	2922	HH04SD1	SINGLE	CERA	YES	647	
					2653	HH04SDMC	SINGLE	CARBON	YES	559
					2630	HM012SBMC1	TWIN	CARBON	NO	1009
					1765	HMG12SD	TWIN	ORGANIC	YES	596
RSX	2.0L	02-07	K20	2023	HH03SD	SINGLE	CERA	YES	422	
					2113	HH03SBMC	SINGLE	CARBON	NO	405
					2428	HM032SBL	TWIN	CERA	NO	1012
TSX	2.4L	03-08	K24	2023	HH03SD	SINGLE	CERA	YES	422	
					2113	HH03SBMC	SINGLE	CARBON	NO	405
					2428	HM032SBL	TWIN	CERA	NO	1012
BMW										
323i, 323is, 323Ci	2.5L	98	M52	2653	BH02SD	SINGLE	CERA	YES	612	
323is, 323Ci	2.5L	99	M52	2653	BH02SD	SINGLE	CERA	YES	612	
328i, 328Ci	2.8L	96-99	M52	2653	BH02SD	SINGLE	CERA	YES	612	
Z3	2.8L	97-98	M52	2653	BH02SD	SINGLE	CERA	YES	612	

Hyper Series Clutch Kits Do Not Include Bearing

TQ Capac @Whls	Disc Size (mm)	Type (Push or Pull)	Spline Teeth/Major Dia (mm)	Flywheel to Crank Bolt ft-lb	PP Assby. to Flywheel ft-lb	Notes	Standard Clutch Kit Part #
235	200	PUSH	24T/25	77	23	Cable clutch	08017
427	184	PUSH	24T/25	77	23	Cable clutch	---
168	200	PUSH	24T/26	77	23	Cable clutch	08028
235	200	PUSH	24T/26	77	23	Cable clutch	---
427	184	PUSH	24T/26	77	23	Cable clutch	---
168	200	PUSH	24T/26	77	23	Hydraulic clutch	KHC05
235	200	PUSH	24T/26	77	23	Hydraulic clutch	---
427	184	PUSH	24T/26	77	23	Hydraulic clutch	---
375	225	PULL	24T/26	77	23	Flywheel crank bolts required Part # 90011-PR7-000 (8pcs), Input shaft must be changed on transmission to 91-96 model	---
223	225	PULL	24T/26	77	23	Flywheel crank bolts required Part # 90011-PR7-000 (8pcs), Input shaft must be changed on transmission to 91-96 model	---
402	200	PULL	24T/26	77	23	Flywheel crank bolts required Part # 90011-PR7-000 (8pcs), Input shaft must be changed on transmission to 91-96 model	---
340	200	PULL	24T/26	77	23	Strap drive, Organic disc, Input shaft must be changed on transmission to 91-96 model	---
375	225	PULL	24T/26	77	23	Flywheel crank bolts required Part # 90011-PR7-000 (8pcs), Input shaft must be changed on transmission to 91-96 model	---
223	225	PULL	24T/26	77	23	Flywheel crank bolts required Part # 90011-PR7-000 (8pcs), Input shaft must be changed on transmission to 91-96 model	---
402	200	PULL	24T/26	77	23	Flywheel crank bolts required Part # 90011-PR7-000 (8pcs), Input shaft must be changed on transmission to 91-96 model	---
340	200	PULL	24T/26	77	23	Strap drive, Organic disc, Input shaft must be changed on transmission to 91-96 model	---
235	200	PUSH	24T/26	91	23	5 Speed/6 Speed	KHC09/KHC10
162	200	PUSH	24T/26	91	23	5 Speed/6 Speed	---
563	200	PUSH	24T/26	91	23	5 Speed/6 Speed	---
235	200	PUSH	24T/26	91	23	6 Speed	HCK1001
162	200	PUSH	24T/26	91	23	6 Speed	---
563	200	PUSH	24T/26	91	23	6 Speed	---
340	225	PUSH	10T/29	78	23	E36	03011
340	225	PUSH	10T/29	78	23	E36	03011
340	225	PUSH	10T/29	78	23	E36	KBM11
340	225	PUSH	10T/29	78	23	E36/7	KBM11

Stage 3 - Stage 4 - Stage 5

Stage 3 - Single Cerametallic ■ Single Carbon ■ Stage 4 - Twin Cerametallic ■ Twin Carbon ■ Twin Organic ■ Stage 5 - Triple Cerametallic ■ Triple Carbon ■

Application	Liter	Year	Engine	Clamp Load	Part #	Number of Disc	Disc Material	Sprung Center (D-core)	Clutch Torque	
Chevrolet										
Camaro	5.7L	98-02	LS-1	3597	GH01SD1	SINGLE	CERA	YES	918	
					2428	GT04SD	TWIN	CERA	YES	1087
					2608	GM013SBMC1	TRIPLE	CARBON	NO	1346
					3035	GT04XD	TWIN	CERA	YES	1415
Camaro SS	6.2L	10-15	LS-3	2428	GT04SD	TWIN	CERA	YES	1087	
					3035	GT04XD	TWIN	CERA	YES	1415
					2608	GM013SBMC1	TRIPLE	CARBON	NO	1346
Corvette	5.7L/6.0L	97-08	LS-1/LS-2/LS-6	3597	GH01SD1	SINGLE	CERA	YES	918	
					2428	GT04SD	TWIN	CERA	YES	1087
					2608	GM013SBMC1	TRIPLE	CARBON	NO	1346
					3035	GT04XD	TWIN	CERA	YES	1415
Corvette	7.0L	06-13	LS-7	3035	GT04XD	TWIN	CERA	YES	1415	
					2608	GM013SBMC1	TRIPLE	CARBON	NO	1346
Corvette	6.2L	09-13	LS-3	2428	GT04SD	TWIN	CERA	YES	1087	
					3035	GT04XD	TWIN	CERA	YES	1415
					2608	GM013SBMC1	TRIPLE	CARBON	NO	1346
Ford										
Focus	2.0L	00-03	Zetec	2653	EH01SD	SINGLE	CERA	YES	612	
Mustang	4.6L	96-10	---	3597	EH02SD1	SINGLE	CERA	YES	909	
					2428	ET01SD	TWIN	CERA	YES	1087
Mustang	4.6L	96-10	---	2428	ET02SD	TWIN	CERA	YES	1087	
Mustang	4.6L	96-10	---	3597	EH04SD1	SINGLE	CERA	YES	909	
					2428	ET03SD	TWIN	CERA	YES	1087
					3035	ET03XD	TWIN	CERA	YES	1317
					1867	ET05SRFA	TWIN	ORGANIC	YES	900
					1867	ET05SRFB	TWIN	ORGANIC	YES	900
Mustang	5.0L	11-16	---	3597	EH06SD1	SINGLE	CERA	YES	909	
					1867	ET05SRFD	TWIN	ORGANIC	YES	900
					3035	ET04XD	TWIN	CERA	YES	1317
Mustang	5.4L	07-14	---	3035	ET03XD	TWIN	CERA	YES	1317	
					1867	ET05SRFC	TWIN	ORGANIC	YES	900
Honda										
Accord	2.2L	94-97	H22A	2023	HH05SD	SINGLE	CERA	YES	422	
Civic SI	1.6L	99-00	B16A	2203	HH02SBMC1	SINGLE	CARBON	NO	422	
					2203	HH02SD	SINGLE	CERA	YES	422
					2023	HM022SR	TWIN	CERA	NO	767

Hyper Series Clutch Kits Do Not Include Bearing

TQ Capac @Whls	Disc Size (mm)	Type (Push or Pull)	Spline Teeth/Major Dia (mm)	Flywheel to Crank Bolt ft-lb	PP Assby. to Flywheel ft-lb	Notes	Standard Clutch Kit Part #
506	250	PUSH	26T/29	74	23	6 Speed, Strap drive type. All others are lug drive type.	04173
604	215	PUSH	26T/29	74	23	6 Speed, Strap drive type.	---
690	225	PUSH	26T/29	74	23	6 Speed	---
847	225	PUSH	26T/29	74	23	6 Speed, Strap drive type.	---
604	215	PUSH	26T/29	74	23	Strap drive type. All others are lug drive type.	---
847	225	PUSH	26T/29	74	23	Strap drive type.	---
690	225	PUSH	26T/29	74	23	Strap drive type.	---
506	250	PUSH	26T/29	74	23	6 Speed, Strap drive type. All others are lug drive type.	04173
604	215	PUSH	26T/29	74	23	C5, Strap drive type.	---
690	225	PUSH	26T/29	74	23	Strap drive type.	---
847	225	PUSH	26T/29	74	23	Strap drive type.	---
847	225	PUSH	26T/29	74	23	Z06, C6, 6 Speed, Strap drive type. All others are lug drive type.	---
690	225	PUSH	26T/29	74	23	Strap drive type.	---
604	215	PUSH	26T/29	74	23	C6, 6 Speed, Strap drive type. All others are lug drive type.	---
847	225	PUSH	26T/29	74	23	Strap drive type.	---
690	225	PUSH	26T/29	74	23	Strap drive type.	---
340	225	PUSH	23T/25	61	23	DOHC, 5 Speed, Not SVT	KFM01
506	250	PUSH	10T/27.5	59	23	8 Bolt Crank, SOHC/DOHC, Strap drive type. All others are lug drive type.	KFM08HP
604	215	PUSH	10T/27.5	59	23	8 Bolt Crank	---
604	215	PUSH	10T/27.5	59	23	6 Bolt Crank, SOHC, Strap drive type. All others are lug drive type.	KFM08HP
506	250	PUSH	26T/29	59	23	8 Bolt Crank, TREMAC TRANS, Strap drive type. All others are lug drive type.	---
604	215	PUSH	26T/29	59	23	8 Bolt Crank	---
847	225	PUSH	26T/29	59	23	Supercharged	---
580	240	PUSH	10T/27.5	59	---	6 Bolt Crank 10-Spline	---
580	240	PUSH	10T/27.5	59	---	8 Bolt Crank 10-Spline	---
506	250	PUSH	23T/26.2	59	23	Also fits BOSS 302	---
580	240	PUSH	23T/26.2	59	---	8 Bolt Crank 23-Spline	---
847	225	PUSH	23T/26.2	59	23	---	---
847	225	PUSH	26T/29	59	23	Shelby GT500/GT500KR, 8 Bolt crank	---
580	240	PUSH	26T/29	59	---	8 Bolt Crank 26-Spline	---
235	200	PUSH	24T/26	---	---	---	KHC03
168	200	PUSH	24T/26	77	23	---	KHC05
235	200	PUSH	24T/26	77	23	---	---
427	184	PUSH	24T/26	77	23	---	---

** needs additional 25 degree turn

Stage 3 - Stage 4 - Stage 5

Stage 3 - Single Cerametallic ■ Single Carbon ■ Stage 4 - Twin Cerametallic ■ Twin Carbon ■ Twin Organic ■ Stage 5 - Triple Cerametallic ■ Triple Carbon ■

Application	Liter	Year	Engine	Clamp Load	Part #	Number of Disc	Disc Material	Sprung Center (D-core)	Clutch Torque	
Honda continued										
Civic SI	2.0L/2.4L	02-15	K20/K24	2023	HH03SD	SINGLE	CERA	YES	422	
					2113	HH03SBMC	SINGLE	CARBON	NO	405
					2428	HM032SBL	TWIN	CERA	NO	1012
Del Sol	1.6L	94-97	B16A	2113	HH02SBMC1	SINGLE	CARBON	NO	405	
					2023	HH02SD	SINGLE	CERA	YES	422
					2023	HM022SR	TWIN	CERA	NO	767
S2000	2.0L/2.2L	00-08	F20C/F22C	2203	HH01SD	SINGLE	CERA	YES	459	
					2270	HH01SDV	SINGLE	CERA/ORG	YES	461
					2540	HH01SDMC1	SINGLE	CARBON	YES	563
					2338	HM052SR	TWIN	CERA	NO	974
Prelude	2.2L	94-97	H22A	2023	HH05SD	SINGLE	CERA	YES	422	
Hyundai										
Genesis	2.0L	10-12		2428	RM012SD	TWIN	CERA	YES	1012	
Infiniti										
G35	3.5L	03-07	VQ35DE	2653	NM072HD	TWIN	CERA	YES	1106	
					3035	NT01HDMC	TWIN	CARBON	YES	1315
Mazda										
MX-5 Miata	1.6L/1.8L	90-05	B6/BP-ZE	2113	ZH03SBMC	SINGLE	CARBON	NO	405	
RX-7	1.3L	86-91	13B-RE	2653	ZH02SBMC	SINGLE	CARBON	NO	508	
					2653	ZH02SD	SINGLE	CERA	YES	562
					2023	ZH02SDMC	SINGLE	CARBON	YES	387
					2428	ZM012SBMC1	TWIN	CARBON	NO	930
					2205	ZM012SD	TWIN	CERA	YES	919
					2205	ZM013SR	TRIPLE	CERA	NO	1378
RX-7	1.3L	93-95	13B-REW	2428	ZM022SBL	TWIN	CERA	NO	985	
					2205	ZM022SD	TWIN	CERA	YES	919
					2653	ZM022SDMC1	TWIN	CARBON	YES	1150
					2428	ZM023SBMC	TRIPLE	CARBON	NO	1394
					2653	ZH02SBMC	SINGLE	CARBON	NO	508
RX-8	1.3L	03-11	13B-MSP	2653	ZH02SD	SINGLE	CERA	YES	562	
					2023	ZH02SDMC	SINGLE	CARBON	YES	387
					2428	ZM012SBMC1	TWIN	CARBON	NO	930
					2205	ZM012SD	TWIN	CERA	YES	919
					2205	ZM013SR	TRIPLE	CERA	NO	1378
					2653	ZH02SBMC	SINGLE	CARBON	NO	508

Hyper Series Clutch Kits Do Not Include Bearing

TQ Capac @Whls	Disc Size (mm)	Type (Push or Pull)	Spline Teeth/Major Dia (mm)	Flywheel to Crank Bolt ft-lb	PP Assy. to Flywheel ft-lb	Notes	Standard Clutch Kit Part #
235	200	PUSH	24T/26	91	23	---	KHC09
162	200	PUSH	24T/26	91	23	---	---
563	200	PUSH	24T/26	91	23	---	---
162	200	PUSH	24T/26	77	23	---	KHC06
235	200	PUSH	24T/26	77	23	---	---
427	184	PUSH	24T/26	77	23	---	---
255	200	PULL	24T/26	95	23	AP-1	KHC06
263	200	PULL	24T/26	95	23	---	KHC06
213	200	PULL	24T/26	95	23	---	---
542	200	PULL	24T/26	95	23	---	---
235	200	PUSH	24T/26	---	---	---	KHC03
563	200	PUSH	23T/26.2	---	---	Turbo	---
615	200	PUSH	24T/25.6	66	23	---	---
516	225	PUSH	24T/25.6	66	23	High clamp load and strap plate driven for high torque and eliminate rattling noise at shifting.	---
162	200	PUSH	22T/24.3	75	23	---	---
223	200	PUSH	23T/26.2	48	23	Turbo, FC3S, Includes Flywheel bolts, Need adapter/counterweight N327-11-521A (Built prior to 1/1989) or N351-11-521 (Built after 1/1989)	10037
340	225	PUSH	23T/26.2	48	23	Need adapter/counterweight N327-11-521A (Built prior to 1/1989) or N351-11-521 (Built after 1/1989)	---
159	200	PUSH	23T/26.2	48	23	Need adapter/counterweight N327-11-521A (Built prior to 1/1989) or N351-11-521 (Built after 1/1989)	---
373	200	PUSH	23T/26.2	48	23	Need adapter/counterweight N327-11-521A (Built prior to 1/1989) or N351-11-521 (Built after 1/1989)	---
511	200	PUSH	23T/26.2	48	23	Need adapter/counterweight N327-11-521A (Built prior to 1/1989) or N351-11-521 (Built after 1/1989)	---
767	200	PUSH	23T/26.2	48	23	Need adapter/counterweight N327-11-521A (Built prior to 1/1989) or N351-11-521 (Built after 1/1989)	---
591	200	PULL	23T/26.4	48	23	Ultra light design, solid hub, Competition use only Need adapter/counterweight N351-11-521.	---
511	200	PULL	23T/26.4	48	23	Need adapter/counterweight N351-11-521.	---
458	225	PULL	23T/26.4	48	23	Need adapter/counterweight N351-11-521.	---
568	200	PULL	23T/26.4	48	23	Need adapter/counterweight N351-11-521.	---
223	200	PUSH	23T/26.2	48	23	Need adapter/counterweight N3Z2-11-52X.	MZK1002
340	225	PUSH	23T/26.2	48	23	Need adapter/counterweight N3Z2-11-52X.	---
159	200	PUSH	23T/26.2	48	23	Need adapter/counterweight N3Z2-11-52X.	---
373	200	PUSH	23T/26.2	48	23	Need adapter/counterweight N3Z2-11-52X.	---
511	200	PUSH	23T/26.2	48	23	Need adapter/counterweight N3Z2-11-52X.	---
767	200	PUSH	23T/26.2	48	23	Need adapter/counterweight N3Z2-11-52X.	---

Stage 3 - Stage 4 - Stage 5

Stage 3 - Single Cerametallic ■ Single Carbon ■ Stage 4 - Twin Cerametallic ■ Twin Carbon ■ Twin Organic ■ Stage 5 - Triple Cerametallic ■ Triple Carbon ■

Application	Liter	Year	Engine	Clamp Load	Part #	Number of Disc	Disc Material	Sprung Center (D-core)	Clutch Torque
-------------	-------	------	--------	------------	--------	----------------	---------------	------------------------	---------------

Mitsubishi

Lancer Evo 4/5/6/7	2.0L	8/96-02	4G63T	2653	MM022HD	TWIN	CERA	YES	1106
				2205	MM022SD	TWIN	CERA	YES	919
				2428	MM022HR	TWIN	CERA	NO	1070
				2428	MM022SBL	TWIN	CERA	NO	984
				2428	MM022SDF	TWIN	ORGANIC	YES	921
				2653	MM023HR	TRIPLE	CERA	NO	1659
				2205	MM023SR	TRIPLE	CERA	NO	1378
Lancer Evo 8/MR/9	2.0L	03-07	4G63T	2653	MM022HD	TWIN	CERA	YES	1106
				2205	MM022SD	TWIN	CERA	YES	919
				2428	MM022HR	TWIN	CERA	NO	1070
				2428	MM022SBL	TWIN	CERA	NO	984
				2428	MM022SDF	TWIN	ORGANIC	YES	921
				2653	MM023HR	TRIPLE	CERA	NO	1659
				2205	MM023SR	TRIPLE	CERA	NO	1378
Lancer Evo 10	2.0L	08-15	4B11T	2205	MM062SD	TWIN	CERA	YES	919
				2653	MM062HD	TWIN	CERA	YES	1106
				2428	MM062SBL	TWIN	CERA	NO	984
				2428	MM062SDF	TWIN	ORGANIC	YES	921
				2205	MM063SB	TRIPLE	CERA	YES	1378
				2653	MM063HB	TRIPLE	CERA	YES	1659

Nissan

240SX	2.4L	89-98	KA24E/DE	2922	NH08SD	SINGLE	CERA	YES	674
				2653	NM092HD	TWIN	CERA	YES	1106
				2653	NM093HB	TRIPLE	CERA	YES	1659
300 ZX	3.0L	90-96	VG30DETT	2428	NM063SBMC	TRIPLE	CARBON	NO	---
				2205	NM063SR	TRIPLE	CERA	NO	1378
350Z	3.5L	03-06	VQ35DE	2653	NM072HD	TWIN	CERA	YES	1106
				3035	NT01HDMC	TWIN	CARBON	YES	1315

Hyper Series Clutch Kits Do Not Include Bearing

TQ Capac @Whls	Disc Size (mm)	Type (Push or Pull)	Spline Teeth/Major Dia (mm)	Flywheel to Crank Bolt ft-lb	PP Assby. to Flywheel ft-lb	Notes	Standard Clutch Kit Part #
615	200	PULL	23T/26.2	99	23	---	---
511	200	PULL	23T/26.2	99	23	---	---
642	215	PULL	23T/26.2	99	23	---	---
590	200	PULL	23T/26.2	99	23	Ultra light design, solid hub, Competition use only	---
553	215	PULL	23T/26.2	90	23	---	---
923	200	PULL	23T/26.2	99	23	---	---
767	200	PULL	23T/26.2	99	23	---	---
615	200	PULL	23T/26.2	99	23	---	---
511	200	PULL	23T/26.2	99	23	---	---
642	215	PULL	23T/26.2	99	23	---	---
590	200	PULL	23T/26.2	99	23	Ultra light design, solid hub, Competition use only	---
553	215	PULL	23T/26.2	90	23	---	---
923	200	PULL	23T/26.2	99	23	---	---
767	200	PULL	23T/26.2	99	23	---	---
511	200	PULL	23T/26.2	99	23	---	MBK1009
615	200	PULL	23T/26.2	99	23	---	---
590	200	PULL	23T/26.2	99	23	Ultra light design, solid hub, Competition use only	---
553	215	PULL	23T/26.2	99	23	---	---
767	200	PULL	23T/26.2	99	23	---	---
923	200	PULL	23T/26.2	99	23	---	---
375	225	PUSH	24T/25.6	112	23	---	06009/ 06054
615	200	PUSH	24T/25.6	112	23	---	---
923	225	PUSH	24T/25.6	112	23	---	---
568	200	PUSH	24T/25.6	66	23	---	---
767	200	PUSH	24T/25.6	66	23	---	---
615	200	PUSH	24T/25.6	66	23	---	---
516	225	PUSH	24T/25.6	66	23	High clamp load, strap plate driven for high torque and eliminate rattling noise at shifting.	---

Stage 3 - Stage 4 - Stage 5

Stage 3 - Single Cerametallic ■ Single Carbon ■ Stage 4 - Twin Cerametallic ■ Twin Carbon ■ Twin Organic ■ Stage 5 - Triple Cerametallic ■ Triple Carbon ■

Application	Liter	Year	Engine	Clamp Load	Part #	Number of Disc	Disc Material	Sprung Center (D-core)	Clutch Torque
-------------	-------	------	--------	------------	--------	----------------	---------------	------------------------	---------------

Nissan continued

GTR R32 (early)	2.6L	8/89-2/93	RB26DETT	2922	NH03SD1	SINGLE	CERA	YES	674
				2428	NM032SBMC	TWIN	CARBON	NO	931
				2205	NM032SD	TWIN	CERA	YES	919
				2428	NM032SBL	TWIN	CERA	NO	984
				2653	NM032SDMC1	TWIN	CARBON	YES	1150
				2653	NM033HRWH	TRIPLE	CERA	NO	1659
				2428	NM033SBMC	TRIPLE	CARBON	NO	1397
GTR R32 (late), R33	2.6L	2/93-98	RB26DETT	2428	NM042SBMC	TWIN	CARBON	NO	931
				2205	NM042SD	TWIN	CERA	YES	919
				2653	NM042SDMC1	TWIN	CARBON	YES	1150
				2630	NM043SBMC1	TRIPLE	CARBON	NO	1513
				2205	NM043SR	TRIPLE	CERA	NO	1378
GTR R34	2.6L	99-02	RB26DETT	2428	NM052SBMC	TWIN	CARBON	NO	931
				2205	NM052SD	TWIN	CERA	YES	919
				2653	NM052SDMC1	TWIN	CARBON	YES	1150
				2428	NM053SBMC	TRIPLE	CARBON	NO	1397
				2205	NM053SR	TRIPLE	CERA	NO	1378
Skyline R32/R33	2.0L/2.5L	5/89-98	RB20, 25DET	2428	NM032SBMC	TWIN	CARBON	NO	931
				2205	NM032SD	TWIN	CERA	YES	919
				2428	NM032SBL	TWIN	CERA	NO	984
				2653	NM032SDMC1	TWIN	CARBON	YES	1150
				2653	NM033HRWH	TRIPLE	CERA	NO	1659
				2428	NM033SBMC	TRIPLE	CARBON	NO	1397

Hyper Series Clutch Kits Do Not Include Bearing

TQ Capac @Whls	Disc Size (mm)	Type (Push or Pull)	Spline Teeth/Major Dia (mm)	Flywheel to Crank Bolt ft-lb	PP Assy. to Flywheel ft-lb	Notes	Standard Clutch Kit Part #
375	225	PUSH	24T/25.6	110	23	---	---
371	200	PUSH	24T/25.6	110	23	Requires changing the release bearing to part no. 30502-14601 (BRG002), BRG002: 45mm contact diameter, to improve pedal effort than stock bearing 62mm diameter, Model not sold in the USA, Includes flywheel bolts	---
511	200	PUSH	24T/25.6	110	23	Requires changing the release bearing to part no. 30502-14601 (BRG002), Includes flywheel bolts	---
590	200	PUSH	24T/25.6	110	23	Ultra light design, rigid discs, competition use only	---
458	225	PUSH	24T/25.6	110	23	Requires changing the release bearing to part no. 30502-14601 (BRG002), Includes flywheel bolts	---
923	200	PUSH	26T/29.4	110	23	Recommended for drag, Requires changing the release bearing to part no. 30502-14601 (BRG002), BRG002: 45mm contact diameter, to improve pedal effort than stock bearing 62mm diameter. Model not sold in the USA, Includes flywheel bolts, Set up for HKS transmission	---
568	200	PUSH	21T/29.8	110	23	Requires changing the release bearing to part no. 30502-14601 (BRG002), Includes flywheel bolts	---
371	200	PULL	24T/25.6	110	23	Model not sold in the USA, Includes flywheel bolts	---
511	200	PULL	24T/25.6	110	23	Model not sold in the USA, Includes flywheel bolts	---
458	225	PULL	24T/25.6	110	23	Model not sold in the USA, Includes flywheel bolts	---
616	200	PULL	24T/25.6	110	23	Model not sold in the USA, Includes flywheel bolts	---
767	200	PULL	24T/25.6	110	23	Model not sold in the USA, Includes flywheel bolts	---
371	200	PULL	24T/25.6	110	23	Model not sold in the USA, Includes flywheel bolts	---
511	200	PULL	24T/25.6	110	23	Model not sold in the USA, Includes flywheel bolts	---
458	225	PULL	24T/25.6	110	23	Model not sold in the USA, Includes flywheel bolts	---
568	200	PULL	24T/25.6	110	23	Model not sold in the USA, Includes flywheel bolts	---
767	200	PULL	24T/25.6	110	23	Model not sold in the USA, Includes flywheel bolts	---
371	200	PUSH	24T/25.6	110	23	Non-GTR, 225mm, Requires changing the release bearing to part no. 30502-14601 (BRG002), BRG002: 45mm contact diameter, to improve pedal effort than stock bearing 62mm diameter. Model not sold in the USA, Includes flywheel bolts	---
511	200	PUSH	24T/25.6	110	23	Requires changing the release bearing to part no. 30502-14601 (BRG002), Includes flywheel bolts	---
590	200	PUSH	24T/25.6	110	23	Ultra light design, rigid discs, competition use only	---
458	225	PUSH	24T/25.6	110	23	Requires changing the release bearing to part no. 30502-14601 (BRG002), Includes flywheel bolts	---
923	200	PUSH	26T/29.4	110	23	Recommended for drag, Requires changing the release bearing to part no. 30502-14601 (BRG002), BRG002: 45mm contact diameter, to improve pedal effort than stock bearing 62mm diameter. Model not sold in the USA, Includes flywheel bolts, Set up for HKS transmission	---
568	200	PUSH	21T/29.8	110	23	Requires changing the release bearing to part no. 30502-14601 (BRG002), Includes flywheel bolts	---

Stage 3 - Stage 4 - Stage 5

Stage 3 - Single Cerametallic ■ Single Carbon ■ Stage 4 - Twin Cerametallic ■ Twin Carbon ■ Twin Organic ■ Stage 5 - Triple Cerametallic ■ Triple Carbon ■

Application	Liter	Year	Engine	Clamp Load	Part #	Number of Disc	Disc Material	Sprung Center (D-core)	Clutch Torque
-------------	-------	------	--------	------------	--------	----------------	---------------	------------------------	---------------

Nissan continued

Skyline R34	2.5L	5/99-00	RB25DET	2428	NM042SBMC	TWIN	CARBON	NO	931
				2205	NM042SD	TWIN	CERA	YES	919
				2653	NM042SDMC1	TWIN	CARBON	YES	1150
				2630	NM043SBMC1	TRIPLE	CARBON	NO	1513
				2205	NM043SR	TRIPLE	CERA	NO	1378
Silvia S13/S14	2.0L	93-99	SR20DET	2922	NH01SBMC	SINGLE	CARBON	NO	633
				2922	NH01SD1	SINGLE	CERA	YES	674
				2205	NM012SD	TWIN	CERA	YES	919
				2428	NM013SBMC	TRIPLE	CARBON	NO	1397
				2653	NM013HB	TRIPLE	CERA	NO	1659
Silvia S15	2.0L	3/99-00	SR20DET	2653	NH02SBMC	SINGLE	CARBON	NO	575
				2922	NH02SD1	SINGLE	CERA	YES	674
				2922	NH02SDMC1	SINGLE	CARBON	YES	---
				2428	NM022SBMC1	TWIN	CARBON	NO	931
				2205	NM022SD	TWIN	CERA	YES	919

Pontiac

Firebird	5.7L	98-02	LS-1	3597	GH01SD1	SINGLE	CERA	YES	918
				2428	GT04SD	TWIN	CERA	YES	1087
				3035	GT04XD	TWIN	CERA	YES	1415
				2608	GM013SBMC1	TRIPLE	CARBON	NO	1346
GTO	5.7L/6.0L	04-06	LS-1/LS-2	3597	GH01SD1	SINGLE	CERA	YES	918
				2428	GT04SD	TWIN	CERA	YES	1087
				3035	GT04XD	TWIN	CERA	YES	1415
				2608	GM013SBMC1	TRIPLE	CARBON	NO	1346
G8 GXP	6.2L	08-09	LS-3	2428	GT04SD	TWIN	CERA	YES	1087
				3035	GT04XD	TWIN	CERA	YES	1415
				2608	GM013SBMC1	TRIPLE	CARBON	NO	1346

Hyper Series Clutch Kits Do Not Include Bearing

TQ Capac @Whls	Disc Size (mm)	Type (Push or Pull)	Spline Teeth/Major Dia (mm)	Flywheel to Crank Bolt ft-lb	PP Assy. to Flywheel ft-lb	Notes	Standard Clutch Kit Part #
371	200	PULL	24T/25.6	110	23	Non-GTR, Model not sold in the USA, Includes flywheel bolts	---
511	200	PULL	24T/25.6	110	23	Non-GTR, Model not sold in the USA, Includes flywheel bolts	---
458	225	PULL	24T/25.6	110	23	Non-GTR, Model not sold in the USA, Includes flywheel bolts	---
616	200	PULL	24T/25.6	110	23	Non-GTR, Model not sold in the USA, Includes flywheel bolts	---
767	200	PULL	24T/25.6	110	23	Non-GTR, Model not sold in the USA, Includes flywheel bolts	---
246	225	PUSH	24T/25.6	66	23	5 Speed, Turbo, Model not sold in the USA	---
375	225	PUSH	24T/25.6	66	23	5 Speed, Turbo, Model not sold in the USA	---
511	200	PUSH	24T/25.6	66	23	5 Speed, Turbo, Requires changing the release bearing to part no. 30502-14601 (BRG002), BRG002: 45mm contact diameter, to improve pedal effort than stock bearing 62mm diameter. Model not sold in the USA, Includes flywheel bolts	---
568	200	PUSH	24T/25.6	66	23	5 Speed, Turbo, Requires changing the release bearing to part no. 30502-14601 (BRG002), BRG002: 45mm contact diameter, to improve pedal effort than stock bearing 62mm diameter. Model not sold in the USA, Includes flywheel bolts	---
923	200	PUSH	24T/25.6	66	66	5 Speed, Turbo, Requires changing the release bearing to part no. 30502-14601 (BRG002), BRG002: 45mm contact diameter, to improve pedal effort than stock bearing 62mm diameter. Model not sold in the USA, Includes flywheel bolts	---
223	225	PUSH	24T/25.6	66	23	6 Speed, Turbo, Model not sold in the USA, Includes flywheel bolts	---
375	225	PUSH	24T/25.6	66	23	6 Speed, Turbo, Model not sold in the USA, Includes flywheel bolts	---
246	225	PUSH	24T/25.6	66	23	6 Speed, Turbo, Requires changing the release bearing to part no. 30502-14601 (BRG002), BRG002: 45mm contact diameter, to improve pedal effort than stock bearing 62mm diameter. Model not sold in the USA, Includes flywheel bolts	---
371	200	PUSH	24T/25.6	66	23	6 Speed, Turbo, Requires changing the release bearing to part no. 30502-14601 (BRG002), BRG002: 45mm contact diameter, to improve pedal effort than stock bearing 62mm diameter. Model not sold in the USA, Includes flywheel bolts	---
511	200	PUSH	24T/25.6	66	23	6 Speed, Turbo, Requires changing the release bearing to part no. 30502-14601 (BRG002), BRG002: 45mm contact diameter, to improve pedal effort than stock bearing 62mm diameter. Model not sold in the USA, Includes flywheel bolts	---
506	250	PUSH	26T/29	74	23	6 Speed, Strap drive type. All others are lug drive type.	04173
604	215	PUSH	26T/29	74	23	6 Speed, Strap drive type. All others are lug drive type.	---
847	225	PUSH	26T/29	74	23	6 Speed, Strap drive type. All others are lug drive type.	---
690	225	PUSH	26T/29	74	23	6 Speed, Strap drive type. All others are lug drive type.	---
506	250	PUSH	26T/29	74	23	6 Speed, Strap drive type. All others are lug drive type.	04173
604	215	PUSH	26T/29	74	23	6 Speed, Strap drive type. All others are lug drive type.	---
847	225	PUSH	26T/29	74	23	6 Speed, Strap drive type. All others are lug drive type.	---
690	225	PUSH	26T/29	74	23	6 Speed, Strap drive type. All others are lug drive type.	---
604	215	PUSH	26T/29	74	23	6 Speed, Strap drive type. All others are lug drive type.	---
847	225	PUSH	26T/29	74	23	6 Speed, Strap drive type. All others are lug drive type.	---
690	225	PUSH	26T/29	74	23	6 Speed, Strap drive type. All others are lug drive type.	---

Stage 3 - Stage 4 - Stage 5

Stage 3 - Single Cerametallic ■ Single Carbon ■ Stage 4 - Twin Cerametallic ■ Twin Carbon ■ Twin Organic ■ Stage 5 - Triple Cerametallic ■ Triple Carbon ■

Application	Liter	Year	Engine	Clamp Load	Part #	Number of Disc	Disc Material	Sprung Center (D-core)	Clutch Torque
-------------	-------	------	--------	------------	--------	----------------	---------------	------------------------	---------------

Porsche

911	3.6L	---	---	2518	PM012SDMC1	TWIN	CARBON	YES	1099
				2518	PM013SBMC1	TRIPLE	CARBON	NO	1648

Saab

9-2X	2.0L	05	---	2922	FH01SD1	SINGLE	CERA	YES	689
				2630	FM012SBMC1	TWIN	CARBON	NO	1009
				2205	FM012SD	TWIN	CERA	YES	919
	2.5L	06	---	2428	FM032SD	TWIN	CERA	YES	1012

Scion

xA	1.5L	03-06	1NZ-FE	2113	TH06SBMC	SINGLE	CARBON	YES	405
xB	1.5L	03-06	1NZ-FE	2113	TH06SBMC	SINGLE	CARBON	YES	405
FR-S	2.0L	13-16	D-4S	2203	TH08SDV	SINGLE	CERA/ORG	YES	459
				2653	TM052SD	TWIN	CERA	YES	1106

Subaru

BAJA	2.5L	04-05	EJ25T	2922	FH01SD1	SINGLE	CERA	YES	689
				2630	FM012SBMC1	TWIN	CARBON	NO	1009
				2205	FM012SBL	TWIN	CERA	NO	919
				2205	FM012SD	TWIN	CERA	YES	919
				2205	FM012SDL	TWIN	CERA	YES	919
BRZ	2.0L	13-19	FA20	2203	TH08SDV	SINGLE	CERA/ORG	YES	459
				2653	TM052SD	TWIN	CERA	YES	1106
Forester	2.5L	04-05	EJ25T	2922	FH01SD1	SINGLE	CERA	YES	689
				2630	FM012SBMC1	TWIN	CARBON	NO	1009
				2205	FM012SBL	TWIN	CERA	NO	919
				2205	FM012SD	TWIN	CERA	YES	919
				2205	FM012SDL	TWIN	CERA	YES	919
Impreza WRX	2.0L	02-05	EJ20T	2922	FH01SD1	SINGLE	CERA	YES	689
				2630	FM012SBMC1	TWIN	CARBON	NO	1009
				2428	FM012SBL	TWIN	CERA	NO	984
				2205	FM012SD	TWIN	CERA	YES	919
				2428	FM012SDL	TWIN	CERA	YES	984
				2630	FM013SBMC1	TRIPLE	CARBON	YES	1513
				2653	FM013HB	TRIPLE	CERA	YES	1659
				2428	FM032SD	TWIN	CERA	YES	1012

Hyper Series Clutch Kits Do Not Include Bearing

TQ Capac @Whls	Disc Size (mm)	Type (Push or Pull)	Spline Teeth/Major Dia (mm)	Flywheel to Crank Bolt ft-lb	PP Assby. to Flywheel ft-lb	Notes	Standard Clutch Kit Part #
475	225	PULL	23T/26.2	---	---	964, 993, 996 (GT3 only), Additional OE items required (Release bearing: 944 116 080 01, Guide tube: 950 116 813 30, Crank bolts: 928 102 151 01, Pilot bearing: 931 102 111 00)	---
665	225	PULL	23T/26.2	---	---	993, 996, Turbo, Additional OE items required (Release bearing: 944 116 080 01, Guide tube: 950 116 813 30, Crank bolts: 928 102 151 01, Pilot bearing: 931 102 111 00)	---
375	225	PULL	24T/25.2	55	23	Aero, Turbo	KSB03
402	200	PULL	24T/25.2	55	23	---	---
511	200	PULL	24T/25.2	55	23	---	---
563	200	PUSH	24T/25.2	55	23	Turbo	FJK1001
162	200	PUSH	21T/24.1	66	23	---	KTY15
162	200	PUSH	21T/24.1	66	23	---	KTY15
255	200	PUSH	24T/25.2	55	23	---	FJK1005
615	200	PUSH	24T/25.2	55	23	---	---
375	225	PULL	24T/25.2	55	23	Turbo	KSB03
402	200	PULL	24T/25.2	55	23	---	---
511	200	PULL	24T/25.2	55	23	Includes flywheel bolts, Ultra light design, solid hub, Competition use only	---
511	200	PULL	24T/25.2	55	23	---	---
511	200	PULL	24T/25.2	55	23	Includes flywheel bolts, Ultra light design, Dampened discs	---
255	200	PUSH	24T/25.2	55	23	---	FJK1005
615	200	PUSH	24T/25.2	55	23	---	---
375	225	PULL	24T/25.2	55	23	Turbo	KSB03
402	200	PULL	24T/25.2	55	23	---	---
511	200	PULL	24T/25.2	55	23	Includes flywheel bolts	---
511	200	PULL	24T/25.2	55	23	Includes flywheel bolts, Ultra light design, Solid hub, Competition use only	---
511	200	PULL	24T/25.2	55	23	Includes flywheel bolts	---
375	225	PULL	24T/25.2	55	23	Turbo, (GC8, GF8, GDA)	KSB03
402	200	PULL	24T/25.2	55	23	---	---
590	200	PULL	24T/25.2	55	23	Includes flywheel bolts, Ultra light design, Solid hub, Competition use only	---
511	200	PULL	24T/25.2	55	23	Includes flywheel bolts	---
590	200	PULL	24T/25.2	55	23	Includes flywheel bolts, Ultra light design, Dampened discs	---
616	200	PULL	24T/25.2	55	23	---	---
923	200	PULL	24T/25.2	55	23	---	---
563	200	PUSH	24T/25.2	55	23	5 Speed	---

** needs additional 25 degree turn

Stage 3 - Stage 4 - Stage 5

Stage 3 - Single Cerametallic ■ Single Carbon ■ Stage 4 - Twin Cerametallic ■ Twin Carbon ■ Twin Organic ■ Stage 5 - Triple Cerametallic ■ Triple Carbon ■

Application	Liter	Year	Engine	Clamp Load	Part #	Number of Disc	Disc Material	Sprung Center (D-core)	Clutch Torque
-------------	-------	------	--------	------------	--------	----------------	---------------	------------------------	---------------

Subaru continued

Impreza WRX STI	2.5L	04-19	EJ25T	2922	FH02SD1	SINGLE	CERA	YES	689	
					2203	FM022SD	TWIN	CERA	YES	919
					2428	FM022SDL	TWIN	CERA	YES	984
					2653	FM022HD	TWIN	CERA	YES	1106
					2428	FM022HR	TWIN	CERA	NO	1070
					2428	FM022SBL	TWIN	CERA	NO	984
					2428	FM022SDF	TWIN	ORGANIC	YES	921
					2203	FM023SB	TRIPLE	CERA	NO	1378
Legacy GT	2.5L	05-11	EJ25T	2428	FM032SD	TWIN	CERA	YES	1012	
Legacy GT Spec B	2.5L	07-09	EJ25T	2922	FH02SD1	SINGLE	CERA	YES	689	
					2203	FM022SD	TWIN	CERA	YES	919
					2428	FM022SDL	TWIN	CERA	YES	984
					2653	FM022HD	TWIN	CERA	YES	1106
					2428	FM022HR	TWIN	CERA	NO	1070
					2428	FM022SBL	TWIN	CERA	NO	984
					2428	FM022SDF	TWIN	ORGANIC	YES	921
					2203	FM023SB	TRIPLE	CERA	NO	1378

Toyota

Celica	2.0L	90-94	3S-GTE	2653	TH02SBMC	SINGLE	CARBON	NO	559				
					2653	TH02SD	SINGLE	CERA	YES	612			
Corolla	1.6L	85-89	4A-GE	2023	TH01SD	SINGLE	CERA	YES	422				
GT86	2.0L	13-17	4U-GSE	2203	TH08SDV	SINGLE	CERA/ORG	YES	459				
					2653	TM052SD	TWIN	CERA	YES	1106			
MR-2	1.6L	86-89	4A-GE	2023	TH01SD	SINGLE	CERA	YES	422				
					2.0L	90-95	3S-GTE	2653	TH02SBMC	SINGLE	CARBON	NO	559
								2653	TH02SD	SINGLE	CERA	YES	612
Supra	3.0L	91-92	1JZ-GTE	2653	TH04SD	SINGLE	CERA	YES	612				
					2248	TM032SD	TWIN	CERA	YES	937			
					2630	TM033SBMC1	TRIPLE	CARBON	NO	1513			
Supra	3.0L	93-98	2JZ-GTE	2248	TM042SD	TWIN	CERA	YES	937				
					2810	TM043HBMC	TRIPLE	CARBON	NO	1826			
					2630	TM043SBMC1	TRIPLE	CARBON	NO	1513			
					2248	TM043SR	TRIPLE	CERA	NO	1405			

Hyper Series Clutch Kits Do Not Include Bearing

TQ Capac @Whls	Disc Size (mm)	Type (Push or Pull)	Spline Teeth/Major Dia (mm)	Flywheel to Crank Bolt ft-lb	PP Assby. to Flywheel ft-lb	Notes	Standard Clutch Kit Part #
375	225	PULL	24T/25.2	55	23	Turbo, Also fits JDM (and European) STI 2.0L Turbo (GDB 6 Speed)	FJK1000
511	200	PULL	24T/25.2	55	23	---	---
590	200	PULL	24T/25.2	55	23	Ultra light design, Dampened discs	---
615	200	PULL	24T/25.2	55	23	---	---
642	215	PULL	24T/25.2	55	23	---	---
590	200	PULL	24T/25.2	55	23	Ultra light design, Solid hub, Competition use only	---
553	215	PULL	24T/25.2	55	23	---	---
766	200	PULL	24T/25.2	55	23	---	---
563	200	PUSH	24T/25.2	55	23	Turbo, 5 Speed	FJK1001FW
375	225	PULL	24T/25.2	55	23	Turbo, 6 Speed	FJK1002
511	200	PULL	24T/25.2	55	23	---	---
590	200	PULL	24T/25.2	55	23	Ultra light design, Dampened discs	---
615	200	PULL	24T/25.2	55	23	---	---
642	215	PULL	24T/25.2	55	23	---	---
590	200	PULL	24T/25.2	55	23	Ultra light design, Solid hub, Competition use only	---
553	215	PULL	24T/25.2	55	23	---	---
766	200	PULL	24T/25.2	55	23	---	---
223	225	PUSH	21T/29.8	80	23	Turbo, Includes flywheel bolts, bearing, sleeve	KTY11
340	225	PUSH	21T/29.8	80	23	---	---
235	200	PUSH	21T/24.1	55	23	AE86/AE92/AE101/AE111, GTS	16070
255	200	PUSH	24T/25.2	55	23	---	---
615	200	PUSH	24T/25.2	55	23	---	---
235	200	PUSH	21T/24.1	55	23	---	16074
223	225	PUSH	21T/29.8	80	23	Turbo, Includes flywheel bolts, bearing, sleeve	16062
340	225	PUSH	21T/29.8	80	23	---	---
340	225	PULL	21T/30	36*	23	Turbo	16085
521	200	PULL	21T/30	36*	23	---	---
616	200	PULL	21T/30	36*	23	---	---
521	200	PULL	14T/32	36*	23	8 flywheel crank bolts required. Part Number 90910-02103.	---
743	225	PULL	14T/32	36*	23	---	---
616	200	PULL	14T/32	36*	23	---	---
782	200	PULL	14T/32	36*	23	---	---

* needs additional 90 degree turn ** needs additional 25 degree turn

Hyper Accessory Kits

EXEDY Hyper Accessory Kits gives you the parts you need when installing your EXEDY Hyper clutch kit. Each kit includes bearings, an alignment tool, and any additional accessories required for the installation. All the parts you need in one convenient package.

Application	Liter	Year	Engine	Part #	Accessory Kit #
Acura					
Integra	1.8L	90-91	B18A1	HH06SD	HCAK100
				HM042SR	HCAK100
Integra	1.7 / 1.8L	92-93	B17A / B18A	HH02SBMC1	HCAK100
				HH02SD	HCAK100
				HM022SR	HCAK100
Integra	1.8L	94-01	B18B / B18C	HH02SBMC1	HCAK101
				HH02SD	HCAK101
				HM022SR	HCAK101
NSX	3.0L	91-96	C30A1	HH04SD1	HCAK102
				HH04SDMC	HCAK102
				HM012SBMC1	HCAK102
				HM012SD	HCAK102
				HM013SB	HCAK102
NSX	3.2L	97-05	C32B1	HH04SD1	HCAK102
				HH04SDMC	HCAK102
				HM012SBMC1	HCAK102
				HM012SD	HCAK102
				HM013SB	HCAK102
RSX	2.0L	02-07	K20	HH03SD	HCAK103
				HH03SBMC	HCAK103
				HM032SBL	HCAK103
TSX	2.4L	03-08	K24	HH03SD	HCAK103
				HH03SBMC	HCAK103
				HM032SBL	HCAK103
BMW					
Mini Cooper-S	1.6L	01-06	W11B16	BH01SD	BMAK100
323i, 323is, 323Ci	2.5L	98	M52	BH02SD	BMAK101
323is, 323Ci	2.5L	99	M52	BH02SD	BMAK101
Chevrolet					
Camaro	5.7L	98-02	LS-1	GH01SD1	GMAK100
				GT04SD	GMAK100
				GM013SBMC1	GMAK100
				GT04XD	GMAK100

Application	Liter	Year	Engine	Part #	Accessory Kit #
Chevrolet continued					
Corvette	5.7L	97-04	LS-1/6	GH01SD1	GMAK100
				GT01SD	GMAK100
				GT04SD	GMAK100
				GM013SBMC1	GMAK100
				GT04XD	GMAK100
Ford					
Mustang	4.6L	96-04	---	EH02SD1	FMAK101
				ET02SD	FMAK101
Honda					
Accord	2.2L	94-97	H22A	HH05SD	HCAK104
Civic SI	1.6L	99-00	B16A	HH02SBMC1	HCAK101
				HH02SD	HCAK101
				HM022SR	HCAK101
Civic SI	2.0L/2.4L	02-15	K20/K24	HH03SD	HCAK103
				HH03SBMC	HCAK103
				HM032SBL	HCAK103
Del Sol	1.6L	94-97	B16A	HH02SBMC	HCAK101
				HH02SD	HCAK101
				HM022SR	HCAK101
S2000	2.0L/2.2L	00-08	F20C / F22C	HH01SD	HCAK105
				HH01SDMC1	HCAK105
				HM052SBMC	HCAK105
				HM052SR	HCAK105
Prelude	2.2L	1994-97	H22A	HH05SD	HCAK104
Hyundai					
Genesis	2.0L	10-12	4B11	RM012SD	HYAK100
Infiniti					
G35	3.5L	03-07	VQ35DE	NM072SBMC1	NSAK100
				NM072SDMC1	NSAK100
				NM072HD	NSAK100
				NT01HDMC	NSAK100
				NMA73HBMC1	NSAK100

Hyper Accessory Kits

Application	Liter	Year	Engine	Part #	Accessory Kit #
Mazda					
MX-5 Miata	1.6L/1.8L	90-05	B6 / BP-ZE	ZH03SBMC	MZAK100
				ZH03SDMC1	MZAK100
RX-7	1.3L	86-91	13B-RE	ZH02SBMC	MZAK101
				ZH02SD	MZAK101
				ZH02SDMC	MZAK101
				ZM012SBMC	MZAK101
				ZM012SD	MZAK101
				ZM013SR	MZAK101
RX-7	1.3L	93-95	13B-REW	ZH01SD1	MZAK102
				ZM022SBMC1	MZAK102
				ZM022SD	MZAK102
				ZM022SDMC1	MZAK102
				ZM023SBMC	MZAK102
				ZM023SR	MZAK102
RX-8	1.3L	03-07	13B-MSP	ZH02SBMC	MZAK101
				ZH02SD	MZAK101
				ZH02SDMC	MZAK101
				ZM012SBMC	MZAK101
				ZM012SD	MZAK101
				ZM013SR	MZAK101
Mitsubishi					
Lancer Evo 4/5/6/7	2.0L	8/96-02	4G63T	MM022HBMC	MBAK100
				MM022HD	MBAK100
				MM022SD	MBAK100
				MM022SDF	MBAK100
				MM022HR	MBAK100
				MM022SBL	MBAK100
				MM023HBMC1	MBAK100
				MM023HR	MBAK100
				MM023SR	MBAK100
				Lancer Evo 8/MR/9	2.0L
MM022HD	MBAK100				
MM022SD	MBAK100				
MM022SDF	MBAK100				
MM022HR	MBAK100				
MM022SBL	MBAK100				
MM023HBMC1	MBAK100				
MM023HR	MBAK100				
MM023SR	MBAK100				

Application	Liter	Year	Engine	Part #	Accessory Kit #
Mitsubishi continued					
Lancer Evo 10	2.0L	08-15	4B11T	MM062SD	MBAK101
				MM062HD	MBAK101
				MM062SDF	MBAK101
				MM062SBL	MBAK101
				MM062SDMC1	MBAK101
				MM063SB	MBAK101
				MM063HB	MBAK101
Nissan					
240SX	2.4L	89-98	KA24E/ DE	NH08SD	NSAK101
				NM092HD	NSAK101
				NM093HB	NSAK101
300 ZX	3.0L	90-96	VG30DETT	NM062SBMC	NSAK101
				NM062SD	NSAK101
				NM063SBMC	NSAK101
				NM063SR	NSAK101
350Z	3.5L	03-06	VQ35DE	NM072SBMC1	NSAK100
				NM072SDMC1	NSAK100
				NM072HD	NSAK100
				NT01HDMC	NSAK100
				NMA73HBMC1	NSAK100
GTR R32 (early)	2.6L	8/89-2/93	RB26DETT	NH03SD1	NSAK101
				NM032SBMC	NSAK102
				NM032SD	NSAK102
				NM032SDMC1	NSAK102
				NM033HRW	NSAK102
				NM033HRWH	NSAK102
				NM033HRWT	NSAK102
				NM033SBMC	NSAK102
GTR R32 (late), R33	2.6L	2/93-98	RB26DETT	NM042SBMC	NSAK103
				NM042SD	NSAK103
				NM042SDMC1	NSAK103
				NM043SBMC1	NSAK103
				NM043SR	NSAK103
GTR R34	2.6L	99-02	RB26DETT	NM052SBMC	NSAK103
				NM052SD	NSAK103
				NM052SDMC1	NSAK103
				NM053SBMC	NSAK103
				NM053SR	NSAK103

Hyper Accessory Kits

Application	Liter	Year	Engine	Part #	Accessory Kit #
Nissan continued					
Skyline R32/R33	2.0L/2.5L	5/89-98	RB20, 25DET	NM032SBMC	NSAK102
				NM032SD	NSAK102
				NM032SDMC1	NSAK102
				NM033HRW	NSAK102
				NM033HRWH	NSAK102
				NM033HRWT	NSAK102
				NM033SBMC	NSAK102
Skyline R34	2.5L	5/99-00	RB25DET	NM042SBMC	NSAK103
				NM042SD	NSAK103
				NM042SDMC1	NSAK103
				NM043SBMC1	NSAK103
				NM043SR	NSAK103
Silvia S13/S14	2.0L	93-99	SR20DET	NH01SBMC1	NSAK102
				NH01SD1	NSAK102
				NM012SBMC	NSAK102
				NM012SD	NSAK102
				NM013SBMC	NSAK102
				NM013HB	NSAK102
Silvia S15	2.0L	3/99-00	SR20DET	NH02SBMC1	NSAK102
				NH02SD1	NSAK102
				NH02SDMC1	NSAK102
				NM022SBMC	NSAK102
				NM022SD	NSAK102
Pontiac					
Firebird	5.7L	98-02	LS-1	GH01SD1	GMAK100
				GT04SD	GMAK100
				GT04XD	GMAK100
				GM013SBMC1	GMAK100
GTO	5.7L/6.0L	04-06	LS-1/LS-2	GH01SD1	GMAK100
				GT04SD	GMAK100
				GT04XD	GMAK100
				GM013SBMC1	GMAK100

Application	Liter	Year	Engine	Part #	Accessory Kit #
Saab					
9-2X	2.0L	05	---	FH01SD1	FJAK100
				FM012SBMC1	FJAK100
				FM012SD	FJAK100
				FM012SDMC1	FJAK100
9-2X	2.5L	06	---	FM032SD	FJAK101
Scion					
xA	1.5L	03-06	1NZ-FE	TH06SBMC	TYAK100
				TH06SD	TYAK100
xB	1.5L	03-06	1NZ-FE	TH06SBMC	TYAK100
				TH06SD	TYAK100
FR-S	2.0L	13-16	D-4S	TM052SD	FJAK102
Tc	2.4L	05-10	2AZ-FE	TM012SR	TYAK104
Subaru					
BAJA	2.5L	04-05	EJ25T	FH01SD1	FJAK100
				FM012SBMC1	FJAK100
				FM012SD	FJAK100
				FM012SDMC1	FJAK100
BRZ	2.0L	13-17	FA20	TM052SD	FJAK102
Forester	2.5L	04-05	EJ25T	FH01SD1	FJAK100
				FM012SBMC1	FJAK100
				FM012SD	FJAK100
				FM012SDMC1	FJAK100
Impreza WRX	2.0L	02-05	EJ20T	FH01SD1	FJAK100
				FM012SBMC1	FJAK100
				FM012SD	FJAK100
				FM012SDMC1	FJAK100
				FM013SBMC1	FJAK100
				FM013HB	FJAK100
Impreza WRX	2.5L	06-17	EJ20T	FM032SD	FJAK100
Impreza WRX STI	2.5L	04-17	EJ25T	FH02SD1	FJAK100
				FM022SBMC1	FJAK100
				FM022SD	FJAK100
				FM022HD	FJAK100
				FM022SBL	FJAK100
				FM022HR	FJAK100
				FM022SDF	FJAK100
				FM022SDMC1	FJAK100
				FM023SB	FJAK100
				FM023SBMC1	FJAK100

Hyper Accessory Kits

Application	Liter	Year	Engine	Part #	Accessory Kit #
Subaru continued					
Legacy GT	2.5L	05-11	EJ25T	FM032SD	FJAK101
Legacy GT Spec B	2.5L	07-09	EJ25T	FH02SD1	FJAK100
				FM022SBMC1	FJAK100
				FM022SD	FJAK100
				FM022HD	FJAK100
				FM022HR	FJAK100
				FM022SDF	FJAK100
				FM022SDMC1	FJAK100
				FM023SB	FJAK100
				FM023SBMC1	FJAK100
Toyota					
Celica	2.0L	90-94	3S-GTE	TH02SBMC	TYAK104
				TH02SD	TYAK104
				TM012SR	TYAK104
Corolla	1.6L	85-89	4A-GE	TH01SD	TYAK101
ECHO	1.5L	00-05	1NZ-FE	TH06SD	TYAK100
GT86	2.0L	13-17	4U-GSE	TM052SD	FJAK102
MR-2	1.6L	86-89	4A-GE	TH01SD	FJAK102
MR-2	2.0L	90-95	3S-GTE	TH02SBMC	TYAK104
				TH02SD	TYAK104
				TM012SBMC1	TYAK104
				TM012SR	TYAK104
				TM032SBMC1	TYAK102
Supra	3.0L	91-92	1JZ-GTE	TH04SD	TYAK102
				TM032SBMC1	TYAK102
				TM032SD	TYAK102
				TM032SDMC	TYAK102
				TM033SBMC1	TYAK102
Supra	3.0L	93-98	2JZ-GTE	TM042SBMC1	TYAK103
				TM042SD	TYAK103
				TM042SDMC1	TYAK103
				TM043HBMC	TYAK103
				TM043SBMC1	TYAK103
				TM043SR	TYAK103
				TM043SR	TYAK103
Yaris	1.5L	07-08	1NZ-FE	TH06SD	TYAK100

The page features a large white rectangular area with horizontal lines for writing. This area is overlaid on a faint, light gray technical drawing of a mechanical part, likely a flywheel or a similar component. The drawing includes various parts, bolts, and labels. Visible labels include 'EXEDY' on the left side, 'BSSQ' in the middle-left, and 'CW122' in the bottom-right. The background of the page is a dark blue color with a pattern of white circles and lines, suggesting a technical or engineering theme.

Hyper Builder Series

The EXEDY Hyper Builder Series allows the racer or custom car builder to assemble a clutch kit to fit their specific application. These kits can be used with any of the available flywheels or can be used with your custom made flywheel. These all come as a HD clamp load, push type diaphragm for use with a 44-46mm release bearing. The cerametallic clutch discs are all 200mm diameter with solid hub for reduced mass and high torque holding capacities.

Application	Clamp Load	Part #	Number of Disc	Disc Material	Sprung Center (D-core)	Clutch Torque	Torque Capacity @ Wheels	Disc Size (mm)	Type (Push or Pull)
23 Spline (Getrag)	2653	MMR200	TWIN	CERA	NO	1106	615	200	PUSH
	2653	MMR300	TRIPLE	CERA	NO	1659	923	200	PUSH
26 Spline (Tremec)	2653	GMR200	TWIN	CERA	NO	1106	615	200	PUSH
	2653	GMR300	TRIPLE	CERA	NO	1659	923	200	PUSH
24 Spline (Honda)	2653	HMR200	TWIN	CERA	NO	1106	615	200	PUSH
	2653	HMR300	TRIPLE	CERA	NO	1659	923	200	PUSH
24 Spline (Nissan)	2653	NSR200	TWIN	CERA	NO	1106	615	200	PUSH
	2653	NSR300	TRIPLE	CERA	NO	1659	923	200	PUSH
24 Spline (Subaru)	2653	FJR200	TWIN	CERA	NO	1106	615	200	PUSH
	2653	FJR300	TRIPLE	CERA	NO	1659	923	200	PUSH
21 Spline (Toyota)	2653	TYR200	TWIN	CERA	NO	1106	615	200	PUSH
	2653	TYR300	TRIPLE	CERA	NO	1659	923	200	PUSH



Spline Teeth/ Major Dia (mm)	PP Assby. to Flywheel ft-lb	Notes
23T / 26.2	23	Does not include flywheel, will require custom clutch actuation, bearing contact 44-46mm, bearing stroke 7.5mm
23T / 26.2	23	Does not include flywheel, will require custom clutch actuation, bearing contact 44-46mm, bearing stroke 7.5mm
26T / 29	23	Does not include flywheel, will require custom clutch actuation, bearing contact 44-46mm, bearing stroke 7.5mm
26T / 29	23	Does not include flywheel, will require custom clutch actuation, bearing contact 44-46mm, bearing stroke 7.5mm
24T / 26	23	Does not include flywheel, will require custom clutch actuation, bearing contact 44-46mm, bearing stroke 7.5mm
24T / 26	23	Does not include flywheel, will require custom clutch actuation, bearing contact 44-46mm, bearing stroke 7.5mm
24T / 25.6	23	Does not include flywheel, will require custom clutch actuation, bearing contact 44-46mm, bearing stroke 7.5mm
24T / 25.6	23	Does not include flywheel, will require custom clutch actuation, bearing contact 44-46mm, bearing stroke 7.5mm
24T / 25.2	23	Does not include flywheel, will require custom clutch actuation, bearing contact 44-46mm, bearing stroke 7.5mm
24T / 25.2	23	Does not include flywheel, will require custom clutch actuation, bearing contact 44-46mm, bearing stroke 7.5mm
21T / 29.8	23	Does not include flywheel, will require custom clutch actuation, bearing contact 44-46mm, bearing stroke 7.5mm
21T / 29.8	23	Does not include flywheel, will require custom clutch actuation, bearing contact 44-46mm, bearing stroke 7.5mm

Flywheel Options	Part #
Subaru (EJ, FA)	FM13
Acura NSX	FM14
Mitsubishi Evo IV-IX	FM12
Mitsubishi Evo X	FM59
Nissan Silvia S13, S14	FM01
Nissan Silvia S15	FM02
Nissan Skyline R32, R33	FM03
Nissan Skyline R34	FM04
Nissan 300ZX	FM05
Nissan 350Z	FM34
Nissan 240SX	FM56
Hyundai Genesis 10-12	FM65
Toyota Supra (1JZ, 2JZ)	FM09
Mazda RX7 Turbo (FC, FD)	FM10
Toyota MR2 Turbo (3SGTE)	FM06
Toyota Celica (3SGTE)	FM06
Scion TC 04-10	FM06

Hyper Single Repair Parts

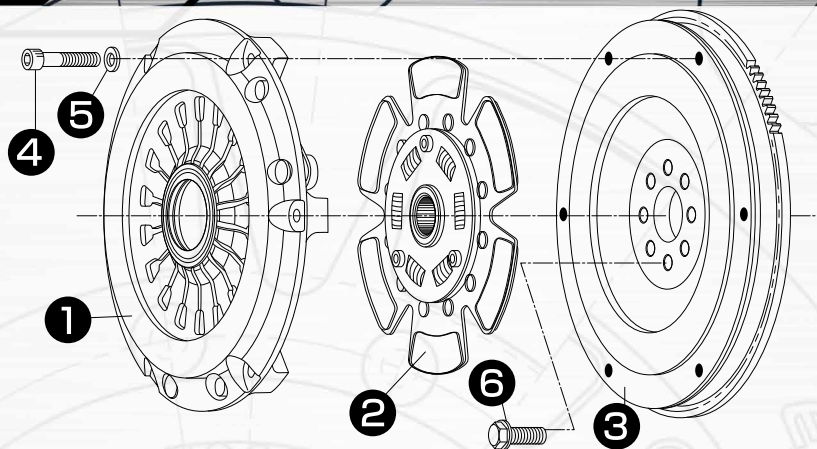

PART NO.	C.COVER Assy	CD Assy	FLYWHEEL	COVER BOLT SE	FLYWHEEL BOLT
	1	2	3	4 & 5	6
BH01SD	CH22S	DH18D	FH31	BS04	BF10
BH02SD	CH21S	DH19D	FH32	BS03	---
EH01SD	CH21S	DH01D	---	BS03	---
EH02SD1	CH14S	DH08D	FH25	BS10	---
EH03SD	CH14S	DH08D	TBA	BS10	---
EH04SD	CH14S	DH09D	FH25	BS10	---
EH05SD	CH21S	DH03D	FM100	BS03	BS50
FH01SD1	CH02S1	DH02S1	FH02	BS03	---
FH01SD	CH02S	DH02D	FH02	BS03	---
FH02SD	CH02S	DH02D	FH08	BS03	---
FH02SD1	CH02S1	DH02D1	FH08	BS03	---
GH01SD	CH14S	DH09D	FH26	BS10	---
GH01SD1	CH14S1	DH09D1	FH26	BS0	---
GH02SD	CH21S	DH25D	FH36	BS03	---
HH01SD	CH03S	DH04D	FH07	BS04	---
HH01SDV	CH56S	DH35D	FH07	BS04	---
HH02SD	CH06S	DH04D	FH09	BS04	---
HH03SD	CH07S	DH04D	FH10	BS04	---
HH04SD	CH13S	DH10D	FH19	BS04	---
HH04SD1	CH13S1	DH10D1	FH19	BS04	---
HH05SD	CH06S	DH04D	FH09	BS04	---
HH06SD	CH06S	DH13D	FH09	BS04	---
NH01SD	CH04S	DH05D	FH05	BS03	---
NH01SD1	CH04S1	DH05D1	FH05	BS03	---
NH02SD	CH04S	DH05D	FH06	BS03	BF08
NH02SD1	CH04S1	DH05D1	FH06	BS03	BF08
NH03SD	CH04S	DH05D	FH04	BS03	---
NH03SD1	CH04S1	DH05D1	FH04	BS03	---
NH04SD	CH02S	DH05D	FH04	BS03	---
NH08SD	CH04S	DH26D	FH37	BS03	---
TH01SD	CH08S	DH06D	FH11	BS04	---
TH02SD	CH12S	DH07D	FH15	BS03	BF04
TH03SD	CH11S	DH07D	FH14	BS03	BF09
TH04SD	CH10S	DH07D	FH13	BS03	---
TH06SD	CH07S	DH06D	FH16	BS04	---
TH08SDV	CH60S	DH37D	FH54	BS04	---
ZH01SD	CH02S	DH03D	FH03	BS03	BF07
ZH01SD1	CH02S1	DH03D1	FH03	BS03	BF07
ZH02SD	CH05S	DH03D	FH03	BS03	BF07

Hyper Carbon Single Repair Parts

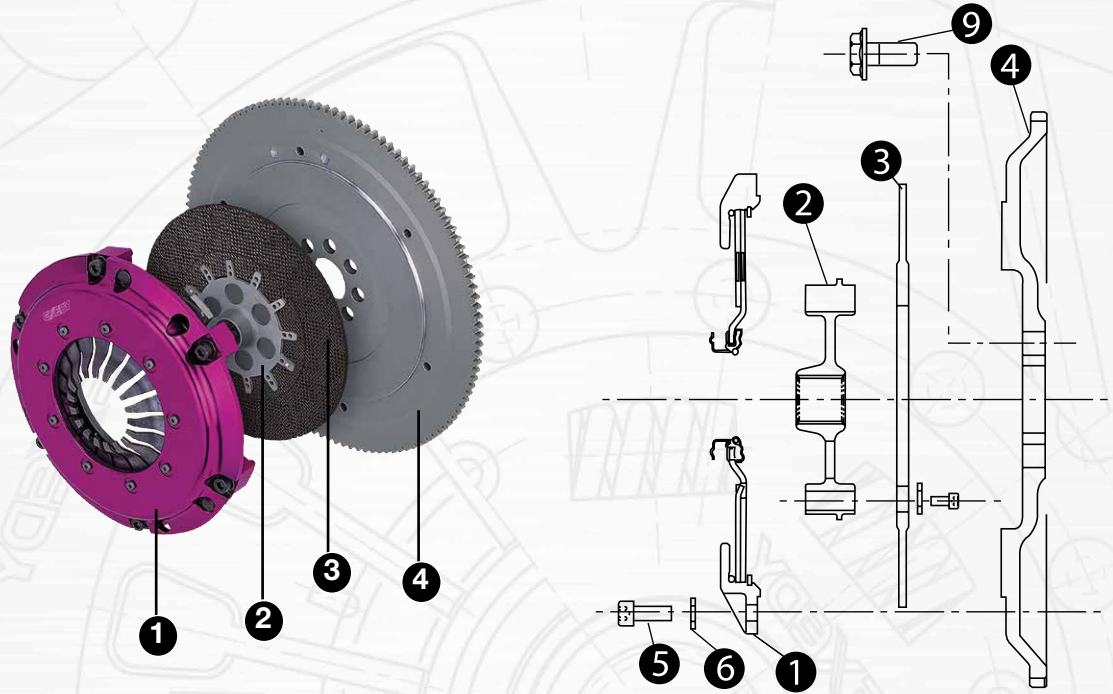

PART NO.	C. COVER ASSY	SPLINE HUB	DISC ASSY	FLYWHEEL	BOLT SET	BOLT F/W	SCREW SET
	1	2	3	4	5 & 6	9	
HH01SDMC1	CH33S	---	DH24D	FH35	BS03	---	---
HH02SBMC	CH06S	SH13	DP01	FH09	BS04	---	SS01
HH02SBMC1	CH36S	SH13	DP01	FH09	BS04	---	SS01
HH03SBMC	CH07S	SH13	DP01	FH10	BS04	---	SS01
HH04SDMC	CH20S	---	DH17D	FH19	BS03	---	---
HH05SBMC	CH06S	SH13	DP01	FH21	BS11	---	SS01
NH01SBMC	CH04S	SH09	DP02	FH05	BS11	---	SS01
NH02SDMC1	CH25S	---	DH21D	FH06	BS03	BF08	---
TH02SBMC	CH12S	SH10	DP02	FH15	BS03	BF04	SS01
TH06SBMC	CH31S	SH18	DP01	FH16	BS04	---	SS01
TH07SBMC	CH31S	SH18	DP01	FH17	BS04	---	SS01
ZH01SBMC	CH27S	SH11	DP02	FH03	BS11	BF07	SS01
ZH02SBMC	CH29S	SH11	DP02	FH03	BS03	BF07	SS01
ZH02SDMC	CH17S	---	DH14D	FH28	BS04	BF07	---
ZH03SBMC	CH31S	SH20	DP01	FH24	BS04	---	SS01
ZH03SDMC	CH28S	---	DH15D	FH29	BS04	---	---

Hyper Multi-Plate Repair Parts

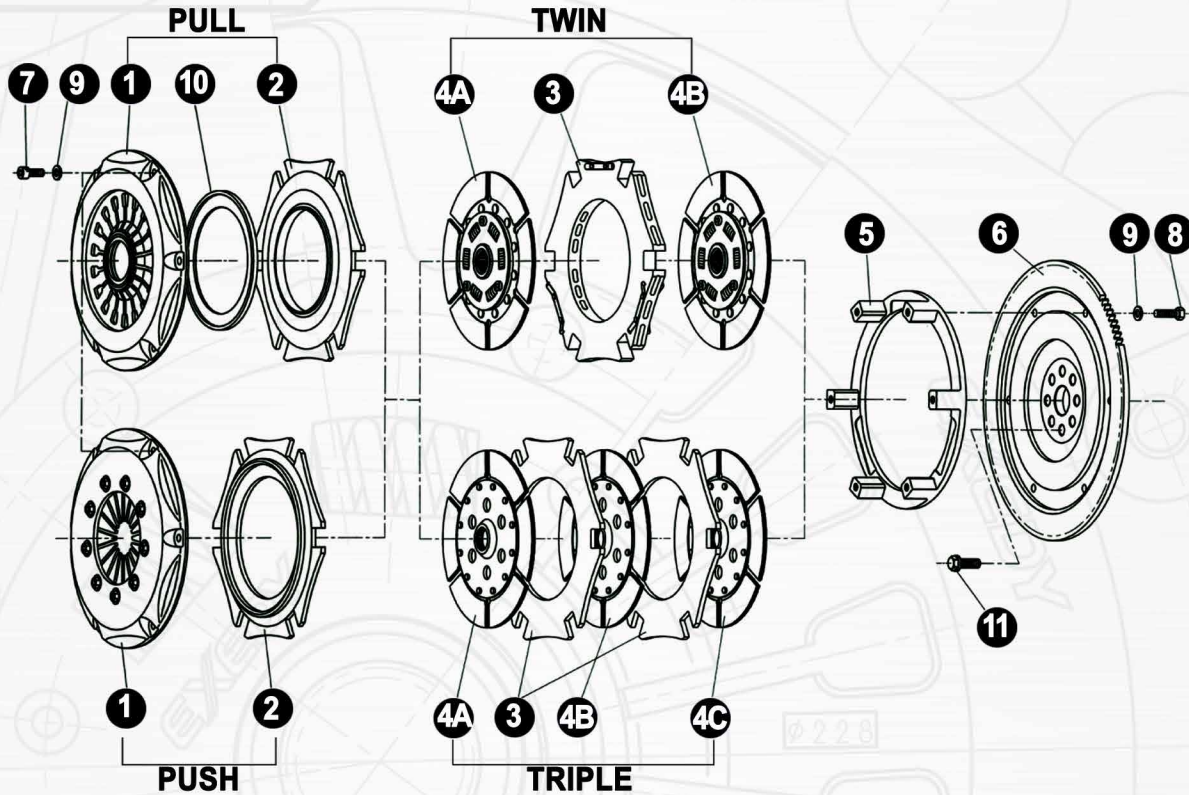

PART NO.	C.COVER	P. PLATE	I.M. PLATE	DISC Assy	DISC Assy	DISC Assy	SPLINE HUB	D.BOSS SET	F/W RING	FLY-WHEEL	COVER BOLT SET	BOLT SET	PIVOT RING	FLYWHEEL BOLT	SPECIAL SLEEVE/ BEARING
	1	2	3	4-A	4-B	4-C			5	6	7,9	7,8,9	10	11	
ET01SD	CT01S	---	IM07	DT01D	DT01D	---	---	---	---	FT01	BS09	---	---	---	---
ET02SD	CT01S	---	IM07	DT01D	DT01D	---	---	---	---	FT03	BS09	---	---	---	---
ET03SD	CT01S	---	IM07	DT02D	DT02D	---	---	---	---	FT01	BS09	---	---	---	---
ET03XD	CT01H	---	IM14	DT05DA	DT05DB	---	---	---	---	FT06	BS17	---	---	BF12	---
ET04XD	CT01H	---	IM14	DT06DA	DT06DB	---	---	---	---	FT06	BS17	---	---	BF12	---
FM012SD	CM02S	PP02	IM01	DM16DA	DM16DB	---	---	---	FR01	FM13	BS05	BS01	PR01	BF08	---
FM013HB	CM02H	PP02	IM02	DL03R	DL03R	DL03R	---	---	FR01	FM13	BS05	BS01	PR01	BF08	---
FM022HD	CM29H	PP02	IM01	DM16DA	DM16DB	---	---	---	FR01	FM13	BS05	BS01	PR01	BF08	---
FM022HR	CM64S	PP45	TBA	TBA	TBA	---	---	TBA	---	TBA	TBA	TBA	PR02	BF08	---
FM022SBL	CM34S	PP09	IM05	DL01R	DL01R	---	CH08	DB02	---	FM24	---	BS05	PR02	BF08	---
FM022SD	CM03S	PP02	IM01	DM16DA	DM16DB	---	---	---	FR01	FM13	BS05	BS01	PR01	BF08	---
FM022SDF	CM64S	PP45	IM17	DM40DA	DM40DB	---	---	TBA	---	TBA	TBA	TBA	PR02	BF08	---
FM022SDL	CM34S	PP09	IM05	DM35DA	DM35DB	---	---	DB02	---	FM24	BS05	---	PR03	BF08	---
FM023SB	CM03S	PP02	IM02	DL03R	DL03R	DL03R	---	---	FR01	FM13	BS05	BS01	PR01	BF08	---
FM032SD	CM61S	PP41	IM01	DM16DA	DM16DB	---	---	---	FR01	FM13	BS05	BS01	---	BF08	---
GT01SD	CT01S	---	IM07	DT02D	DT02D	---	---	---	---	FT02	BS09	---	---	---	---
GT04SD	CT01S	---	IM07	DT04D	DT04D	---	---	---	---	FT02	BS09	---	---	---	---
GT04XD	CT01H	---	IM14	DT05DA	DT05DB	---	---	---	---	FT07	BS16	---	---	---	---
HM012SD	CM08S	PP04	IM01	DM19DA	DM19DB	---	---	---	FR01	FM14	BS05	BS01	---	---	---
HM022SR	CM09S	PP05	IM04	DM22RA	DM22RB	---	---	DB05	---	FM15	BS05	BS01	---	---	---
HM032SBL	CM49S	PP06	IM05	DL05R	DL05R	---	CH11	DB02	---	FM55	BS05	---	---	---	---

PART NO.	C.COVER	P. PLATE	I.M. PLATE	DISC Assy	DISC Assy	DISC Assy	SPLINE HUB	D.BOSS SET	F/W RING	FLY-WHEEL	COVER BOLT SET	BOLT SET	PIVOT RING	FLYWHEEL BOLT	SPECIAL SLEEVE/ BEARING
	1	2	3	4-A	4-B	4-C			5	6	7,9	7,8,9	10	11	
HM042SR	CM09S	PP05	IM04	DM23RA	DM23RB	---	---	DB05	---	FM15	BS05	BS01	---	---	---
HM052SR	CM08S	PP42	IM02	DL05R	DL05R	---	---	---	---	FM66	BS05	BS01	PR05	---	---
HMG12SD	CT06S	---	IM16	DT08DA	DT08DB	---	---	---	---	TBA	---	TBA	---	---	---
MM022HD	CM06H	PP02	IM01	DM13DA	DM13DB	---	---	---	FR01	FM12	BS05	BS01	PR01	---	---
MM022HR	CM63S	PP45	TBA	DM36RA	DM36RB	---	---	TBA	---	TBA	TBA	TBA	PR02	---	---
MM022SBL	CM35S	PP09	IM05	DL01R	DL01R	---	CH07	DB02	---	FM23	---	BS05	PR02	---	---
MM022SD	CM06S	PP02	IM01	DM13DA	DM13DB	---	---	---	FR01	FM12	BS05	BS01	PR01	---	---
MM022SDF	CM63S	PP45	IM17	DM39DA	DM39DB	---	---	TBA	---	TBA	TBA	TBA	PR02	---	---
MM023HR	CM06H	PP02	IM02	DL03R	DL03R	DL03R	CH16	---	FR01	FM12	BS05	BS01	PR01	---	---
MM023SR	CM06S	PP02	IM02	DL03R	DL03R	DL03R	CH16	---	FR01	FM12	BS05	BS01	PR01	---	---
MM062HD	CM06H	PP02	IM01	DM09DA	DM09DB	---	---	---	FR01	FM59	BS05	BS01	PR01	---	---
MM062SBL	CM35S	PP09	IM05	DL01R	DL01R	---	CH07	DB02	---	FM60	---	BS05	PR02	---	---
MM062SD	CM06S	PP02	IM01	DM09DA	DM09DB	---	---	---	FR01	FM59	BS05	BS01	PR01	---	---
MM062SDF	CM63S	PP45	IM17	DM39DA	DM39DB	---	---	TBA	---	TBA	TBA	TBA	PR02	---	---
MM063HB	CM06H	PP02	IM02	DL03R	DL03R	DL03R	CH16	---	FR01	FM59	BS05	BS01	PR01	---	---
MM063SB	CM06S	PP02	IM02	DL03R	DL03R	DL03R	CH16	---	FR01	FM59	BS05	BS01	PR01	---	---
NM012SD	CM01S	PP01	IM01	DM01DA	DM01DB	---	---	---	FR01	FM01	BS05	BS01	---	BF01	---
NM022SD	CM01S	PP01	IM01	DM01DA	DM01DB	---	---	---	FR01	FM02	BS05	BS01	---	BF08	---
NM032SBL	CM39S	PP08	IM05	DL01R	DL01R	---	CH01	DB01	---	FM18	BS05	---	---	BF03	---
NM032SD	CM01S	PP01	IM01	DM01DA	DM01DB	---	---	---	FR01	FM03	BS05	BS01	---	BF03	---
NM033HRW	CM01H	PP01	IM02	DL03R	DL03R	DL03R	---	---	FR01	FM03W	BS05	BS01	---	BF03	---
NM033HRWH	CM01H	PP01	IM02	DM03R	DM03R	DM03R	---	---	FR01	FM03W	BS05	BS01	---	BF03	---
NM033HRWT	CM01H	PP01	IM02	DL03R	DL03R	DL03R	---	---	FR01	FM03W	BS05	BS01	---	BF03	---
NM033SR	CM01S	PP01	IM02	DL03R	DL03R	DL03R	CH12	---	FR01	FM03	BS05	BS01	---	BF03	---
NM042SD	CM02S	PP02	IM01	DM01DA	DM01DB	---	---	---	FR01	FM03	BS05	BS01	PR01	BF03	---
NM043SR	CM02S	PP02	IM02	DL03R	DL03R	DL03R	CH12	---	FR01	FM03	BS05	BS01	PR01	BF03	---
NM052SD	CM03S	PP02	IM01	DM01DA	DM01DB	---	---	---	FR01	FM04	BS05	BS01	PR01	BF03	---
NM053SR	CM03S	PP02	IM02	DL03R	DL03R	DL03R	CH12	---	FR01	FM04	BS05	BS01	PR01	BF03	---
NM062SD	CM01S	PP01	IM01	DM01DA	DM01DB	---	---	---	FR01	FM05	BS05	BS01	---	---	---
NM063SR	CM01S	PP01	IM02	DL03R	DL03R	DL03R	CH12	---	FR01	FM05	BS05	BS01	---	---	---
NM072HD	CM01H	PP01	IM01	DM01DA	DM01DB	---	---	---	---	FM34	BS05	BS01	---	---	---
NM092SD	CM01H	PP01	IM01	DM01DA	DM01DB	---	---	---	FR01	FM56	BS05	BS01	---	BF03	---
NM093HB	CM01H	PP01	IM02	DL03R	DL03R	DL03R	CH12	---	FR01	FM56	BS05	BS01	---	BF03	---
RM012SD	CM60H	PP41	IM01	DM38DA	DM38DB	---	---	---	---	FM65	BS05	BS01	---	---	---
TM012SR	CM01S	PP01	IM03	DM04RA	DM04RB	---	---	---	FR02	FM06	BS06	---	---	BF04	RB01
TM032SD	CM04S	PP03	IM01	DM05DA	DM05DA	---	---	---	FR01	FM09	BS05	BS01	---	---	---
TM042SD	CM05S	PP03	IM01	DM07DA	DM07DA	---	---	---	FR01	FM09	BS05	BS01	---	---	---
TM043SR	CM05S	PP03	IM02	DL03R	DL03R	DL03R	CH15	---	FR01	FM09	BS05	BS01	---	---	---
TM052SD	CM60H	PP41	IM01	DM16DA	DM16DB	---	---	---	FR01	FM13	BS05	BS01	---	BF08	---
ZM012SD	CM01S	PP01	IM01	DM09DA	DM09DB	---	---	---	FR01	FM10	BS05	BS01	---	BF07	---
ZM013HR	CM01H	PP01	IM02	DL03R	DL03R	DL03R	CH16	---	FR01	FM10	BS05	BS01	---	BF07	---
ZM013SR	CM01S	PP01	IM02	DL03R	DL03R	DL03R	CH16	---	FR01	FM10	BS05	BS01	---	BF07	---
ZM022SBL	CM40S	PP09	IM05	DL01R	DL01R	---	CH07	DB02	---	FM22	BS05	---	PR02	BF07	---
ZM022SBL	CM40S	PP09	IM05	DM32DA	DM32DB	---	---	DB02	---	FM22	BS05	---	PR02	BF07	---
ZM022SD	CM02S	PP02	IM01	DM09DA	DM09DB	---	---	---	FR01	FM10	BS05	BS01	PR01	BF07	---
ZM023HR	CM02H	PP02	IM02	DL03R	DL03R	DL03R	CH16	---	FR01	FM10	BS05	BS01	PR01	BF07	---
ZM023SR	CM02S	PP02	IM02	DL03R	DL03R	DL03R	CH16	---	FR01	FM10	BS05	BS01	PR01	BF07	---

Hyper Builder Series Repair Parts

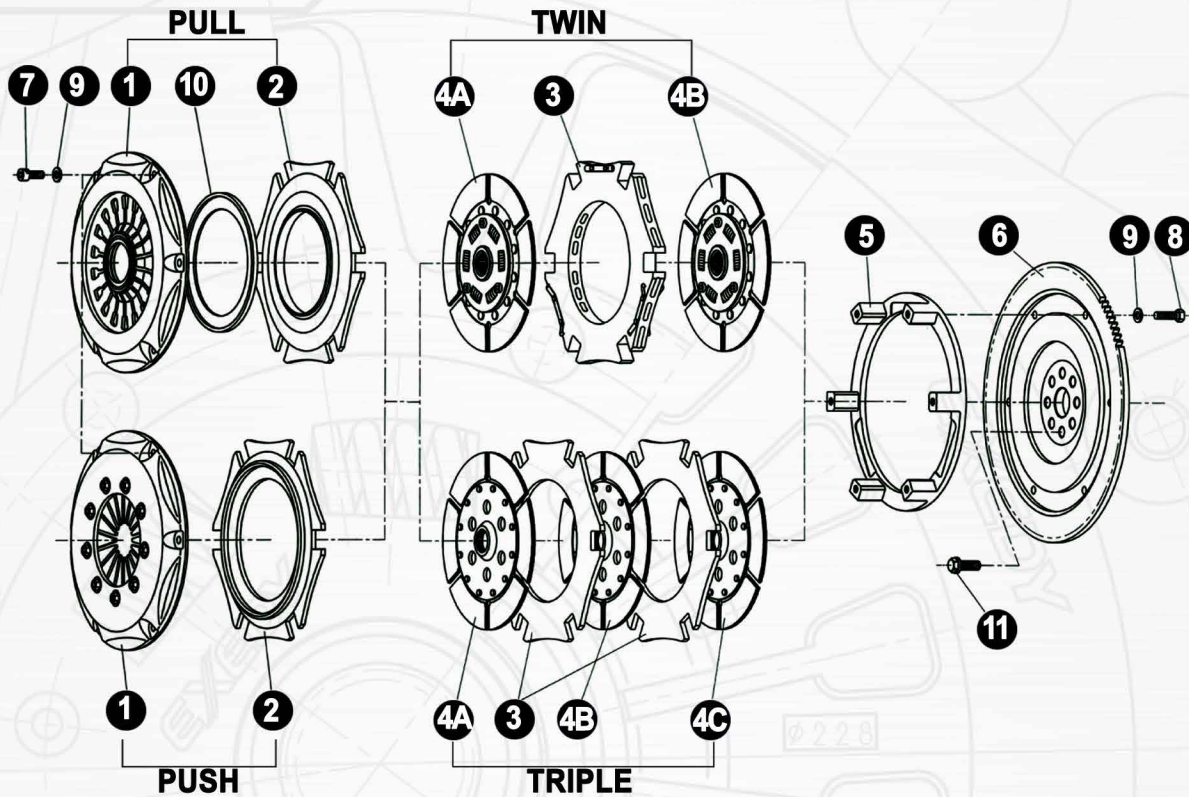

PART NO.	C.COVER	P. PLATE	I.M. PLATE	DISC Assy	DISC Assy	DISC Assy	SPLINE HUB	D.BOSS SET	F/W RING	FLY-WHEEL	COVER BOLT SET	BOLT SET	PIVOT RING	FLYWHEEL BOLT	SPECIAL SLEEVE/ BEARING
	1	2	3	4-A	4-B	4-C			5	6	7,9	7,8,9	10	11	
FJR200	CM01H	PP01	IM02	DL03R	DL03R	---	CH08	---	FR02	---	BS05	BS01	---	---	---
FJR300	CM01H	PP01	IM02	DL03R	DL03R	DL03R	CH10	---	FR01	---	BS05	BS01	---	---	---
GMR200	CM01H	PP01	IM02	DM03R	DM03R	---	---	---	FR02	---	BS05	BS01	---	---	---
GMR300	CM01H	PP01	IM02	DM03R	DM03R	DM03R	---	---	FR01	---	BS05	BS01	---	---	---
HMR200	CM01H	PP01	IM02	DL03R	DL03R	---	CH11	---	FR02	---	BS05	BS01	---	---	---
HMR300	CM01H	PP01	IM02	DL03R	DL03R	DL03R	TBA	---	FR01	---	BS05	BS01	---	---	---
MMR200	CM01H	PP01	IM02	DM11R	DM11R	---	---	---	FR02	---	BS05	BS01	---	---	---
MMR300	CM01H	PP01	IM02	DM11R	DM11R	DM11R	---	---	FR01	---	BS05	BS01	---	---	---
NSR200	CM01H	PP01	IM02	DM02R	DM02R	---	---	---	FR02	---	BS05	BS01	---	---	---
NSR300	CM01H	PP01	IM02	DM02R	DM02R	DM02R	---	---	FR01	---	BS05	BS01	---	---	---
TYR200	CM01H	PP01	IM02	DM04RA	DM04RB	---	---	---	FR02	---	BS05	BS01	---	---	---
TYR300	CM01H	PP01	IM02	DM21R	DM21R	DM21R	---	---	FR01	---	BS05	BS01	---	---	---

A large white rectangular area with horizontal lines for writing, set against a background of a faint technical drawing of a mechanical assembly. The drawing includes various components, bolts, and labels such as 'EXEDY', 'BSSQ', and 'CW122'.

Hyper Carbon Multi-Plate Repair Parts

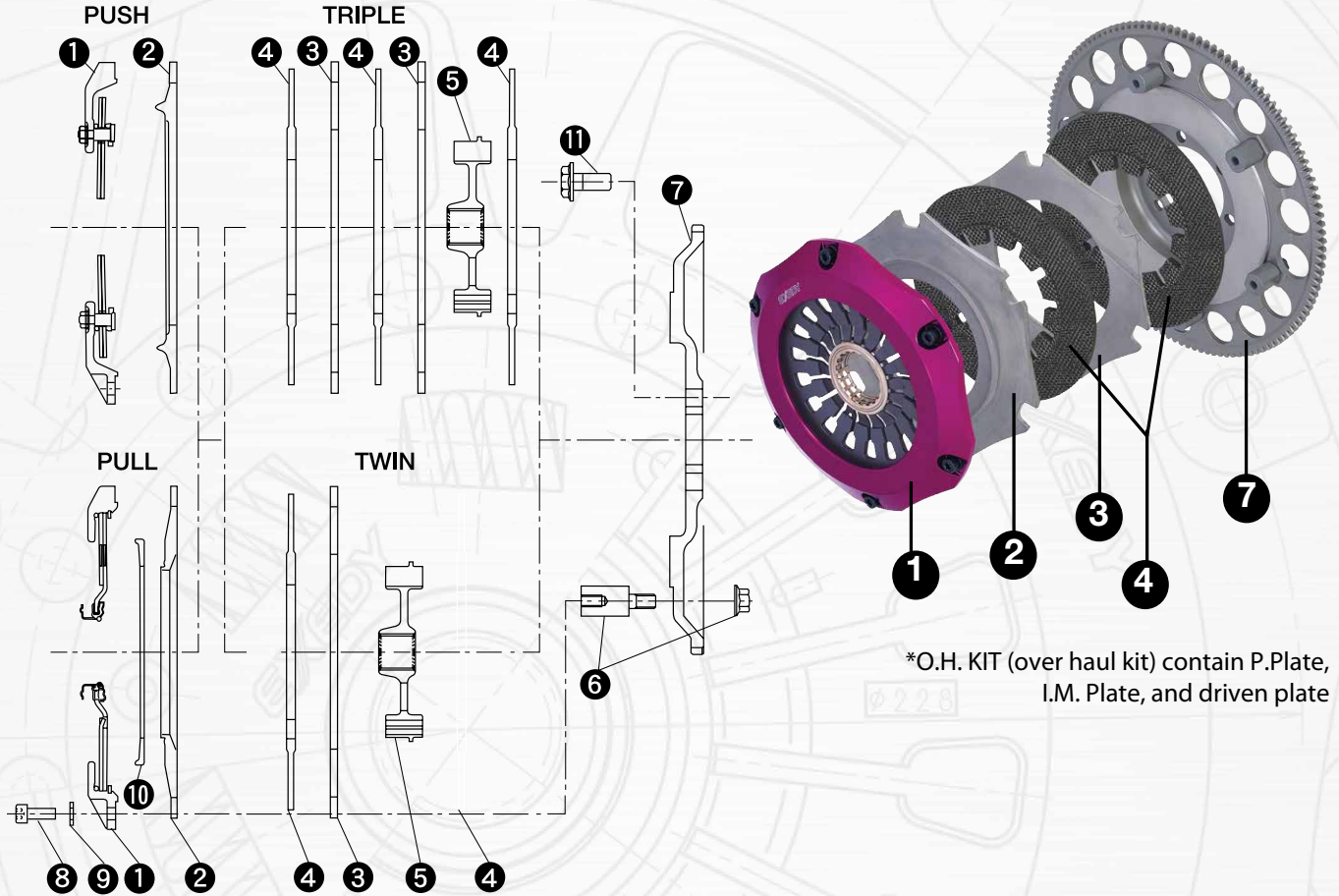

*O.H. KIT (over haul kit) contain P. Plate, I.M. Plate, and driven plate

PART NO.	C.COVER	PRESS PLATE	I.M. PLATE	DRVN PLATE	SPLINE HUB/ DAMPER	D. BOSS SET	F/W	BOLT SET	PVT. RING	BOLT F/W
	1	2	3	4	5	6	7	8 & 9	10	11
FM012SBMC	CM40S	PP09	IM12	DP01	SH08	DB02	FM24	BS05	PR05	BF08
FM012SDMC1	CM32S	PP19	IM11	DP03	DD03	BU03	FM38	BS07	PR06	BF08
FM022SBMC1	CM34S	PP09	IM12	DP01	SH08	DB02	FM24	BS05	PR05	BF08
FM022SDMC1	CM46S	PP19	IM11	DP03	DD03	BU03	FM38	BS07	PR06	BF08
FM023SBMC1	CM40S	PP09	IM12	DP01	SH36	DB01	FM54	BS05	PR05	BF08
GM013SBMC1	CM27S	PP23	IM11	DP02	SH21	BU02	FM45	BS07	---	---
HM012SBMC1	CM38S	PP27	IM12	DP01	SH23	DB01	FM25	BS05	---	---
HM052SBMC	CM38S	PP28	IM12	DP01	SH23	DB02	FM46	BS05	---	---
MM022HBMC	CM13H	PP09	IM05	DP01	SH07	DB02	FM23	BS05	PR02	---
MM023HBMC1	CM19H	PP09	IM05	DP01	SH19	DB01	FM32	BS05	PR02	---
MM062SDMC1	CM45S	PP19	IM11	DP03	DD02	BU03	FM61	BS07	PR06	---

PART NO.	C.COVER	PRESS PLATE	I.M. PLATE	DRVN PLATE	SPLINE HUB/ DAMPER	D. BOSS SET	F/W	BOLT SET	PVT. RING	BOLT F/W
	1	2	3	4	5	6	7	8 & 9	10	11
NM012SBMC	CM39S	PP25	IM12	DP01	SH04	DB02	FM16	BS05	---	BF01
NM013SBMC	CM39S	PP25	IM12	DP01	---	DB01	FM30	BS05	---	BF01
NM022SBMC1	CM39S	PP26	IM12	DP01	SH04	DB01	FM17	BS05	---	BF08
NM032SBMC	CM39S	PP26	IM12	DP01	SH33	DB01	FM18	BS05	---	BF03
NM032SDMC	CM31S	PP32	IM11	DP03	DD01	BU02	FM36	BS07	---	BF03
NM033SBMC	CM39S	PP25	IM12	DP01	SH33	DB01	FM18	BS05	---	BF03
NM042SBMC	CM40S	PP07	IM12	DP01	SH33	DB01	FM18	BS05	PR05	BF03
NM042SDMC1	CM48S	PP15	IM11	DP03	DD01	BU02	FM36	BS07	PR06	BF03
NM043SBMC	CM40S	PP09	IM12	DP01	SH33	DB01	FM18	BS05	PR05	BF03
NM052SBMC	CM34S	PP07	IM12	DP01	SH33	DB01	FM20	BS05	PR05	BF03
NM052SDMC1	CM46S	PP15	IM11	DP03	DD01	BU02	FM33	BS07	PR06	BF03
NM053SBMC	CM34S	PP09	IM12	DP01	SH33	DB01	FM20	BS05	PR05	BF03
NM062SBMC	CM39S	PP26	IM12	DP01	SH33	DB01	FM31	BS05	---	BF10
NM063SBMC	CM39S	PP25	IM12	DP01	SH33	DB01	FM31	BS05	---	BF10
NM072SBMC1	CM39S	PP26	IM12	DP01	SH33	DB01	FM27	BS05	---	BF08
NM072SDMC1	CM31S	PP32	IM11	DP03	DD01	BU02	FM40	BS07	---	---
NMA73HBMC1	CM52H	PP23	IM11	DP02	SH38	BU02	FM58	BS07	---	---
NT01HDMC	CT04H	---	IM13	DP03	DD06	---	FT05	---	---	---
PM012SDMC1	CM53S	PP43	IM11	DP03	DD07	---	FM67	BS12	PR06	---
PM013SBMC1	CM53S	PP44	IM11	DP03	SH40	---	FM67	BS12	PR06	---
TM032SBMC	CM36S	PP27	IM12	DP01	SH06	DB01	FM26	BS05	---	---
TM032SDMC	CM47S	PP15	IM11	DP03	DD04	BU02	FM39	BS07	PR06	---
TM033SBMC1	CM36S	PP28	IM12	DP01	SH06	DB01	FM26	BS05	---	---
TM042SBMC1	CM37S	PP27	IM12	DP01	SH15	DB01	FM26	BS05	---	---
TM042SDMC1	CM33S	PP15	IM11	DP03	DD05	BU02	FM39	BS07	PR06	---
TM043SBMC1	CM37S	PP28	IM12	DP01	SH15	DB01	FM26	BS05	---	---
TM043HBMC	CM51H	PP24	IM08	DP02	SH15	BU02	FM39	BS07	---	---
ZM012SBMC1	CM39S	PP25	IM12	DP01	SH07	DB02	FM22	BS05	---	BF07
ZM022SBMC1	CM40S	PP09	IM12	DP01	SH07	DB02	FM22	BS05	PR05	BF07
ZM022SDMC1	CM46S	PP19	IM11	DP03	DD02	BU03	FM37	BS07	PR06	BF07
ZM023SBMC	CM40S	PP09	IM12	DP01	SH31	DB01	FM29	BS05	PR05	BF07

Conversions

To Convert	Formula
Cubic Inches to Liters	LITERS times 61.024 equals CUBIC INCHES
Liters to Cubic Inches	CUBIC INCHES divided by 61.024 equals LITERS

LITERS	CC/CI	LITERS	CC/CI	LITERS	CC/CI	LITERS	CC/CI
1.0L	61	1.6L	97	1.9L	116	2.2L	2180
1.0L	948	1.6L	98	1.9L	119	2.2L	2184
1.0L	995	1.6L	1565	1.9L	1858	2.2L	2187
1.0L	1000	1.6L	1573	1.9L	1872	2.2L	2189
1.0L	1146	1.6L	1586	1.9L	1895	2.2L	2195
1.1L	1100	1.6L	1587	1.9L	1896	2.2L	2197
1.1L	1116	1.6L	1588	1.9L	1898	2.2L	2200
1.1L	1146	1.6L	1588	1.9L	1900	2.2L	2212
1.2L	1166	1.6L	1589	1.9L	1915	2.2L	2226
1.2L	1189	1.6L	1590	1.9L	1949	2.2L	2237
1.2L	1196	1.6L	1595	2.0L	121	2.3L	138
1.2L	1200	1.6L	1596	2.0L	122	2.3L	140
1.2L	1237	1.6L	1597	2.0L	1952	2.3L	173
1.3L	79	1.6L	1599	2.0L	1955	2.3L	2253
1.3L	81	1.6L	1600	2.0L	1958	2.3L	2254
1.3L	1272	1.6L	1606	2.0L	1967	2.3L	2259
1.3L	1275	1.6L	1639	2.0L	1968	2.3L	2290
1.3L	1289	1.7L	104	2.0L	1970	2.3L	2295
1.3L	1290	1.7L	1678	2.0L	1971	2.3L	2299
1.3L	1295	1.7L	1700	2.0L	1972	2.3L	2300
1.3L	1300	1.7L	1715	2.0L	1974	2.3L	2302
1.3L	1301	1.7L	1721	2.0L	1975	2.3L	2307
1.3L	1308	1.8L	107	2.0L	1983	2.3L	2309
1.3L	1328	1.8L	110	2.0L	1984	2.3L	2316
1.3L	1335	1.8L	112	2.0L	1985	2.3L	2341
1.3L	1342	1.8L	113	2.0L	1986	2.4L	145
1.4L	85	1.8L	1590	2.0L	1989	2.4L	146
1.4L	1393	1.8L	1597	2.0L	1990	2.4L	148
1.4L	1397	1.8L	1751	2.0L	1991	2.4L	150
1.4L	1400	1.8L	1754	2.0L	1994	2.4L	2351
1.4L	1410	1.8L	1760	2.0L	1997	2.4L	2366
1.4L	1415	1.8L	1762	2.0L	1998	2.4L	2389
1.5L	90	1.8L	1770	2.0L	2792	2.4L	2393
1.5L	92	1.8L	1780	2.1L	126	2.4L	2398
1.5L	1452	1.8L	1781	2.1L	2056	2.4L	2400
1.5L	1456	1.8L	1790	2.1L	2100	2.4L	2435
1.5L	1457	1.8L	1793	2.1L	2109	2.4L	2438
1.5L	1468	1.8L	1795	2.1L	2119	2.5L	148
1.5L	1471	1.8L	1796	2.1L	2127	2.5L	150
1.5L	1475	1.8L	1797	2.2L	132	2.5L	151
1.5L	1487	1.8L	1798	2.2L	133	2.5L	152
1.5L	1488	1.8L	1800	2.2L	134	2.5L	153
1.5L	1489	1.8L	1809	2.2L	135	2.5L	173
1.5L	1490	1.8L	1817	2.2L	2109	2.5L	262
1.5L	1491	1.8L	1829	2.2L	2144	2.5L	2451
1.5L	1493	1.8L	1834	2.2L	2147	2.5L	2458
1.5L	1495	1.8L	1836	2.2L	2155	2.5L	2459
1.5L	1497	1.8L	1839	2.2L	2156	2.5L	2475
1.5L	1500	1.8L	1840	2.2L	2163	2.5L	2492
1.5L	1508	1.8L	1845	2.2L	2164	2.5L	2493

To Convert	Formula
Cubic Inches to Liters	LITERS times 61.024 equals CUBIC INCHES
Liters to Cubic Inches	CUBIC INCHES divided by 61.024 equals LITERS

LITERS	CC/CI	LITERS	CC/CI	LITERS	CC/CI	LITERS	CC/CI
2.5L	2494	3.0L	2966	3.8L	230	5.5L	330
2.5L	2497	3.0L	2967	3.8L	231	5.6L	340
2.5L	2498	3.0L	2969	3.8L	232	5.6L	343
2.5L	2500	3.0L	2972	3.8L	3800	5.6L	5576
2.5L	2508	3.0L	2980	3.9L	235	5.7L	347
2.6L	156	3.0L	2983	3.9L	240	5.7L	348
2.6L	2555	3.0L	2985	3.9L	2950	5.7L	350
2.6L	2557	3.0L	2988	3.9L	3900	5.7L	351
2.6L	2559	3.0L	2997	3.9L	3950	5.8L	351
2.6L	2563	3.0L	2999	4.0L	242	5.8L	352
2.6L	2565	3.0L	3000	4.0L	244	5.8L	354
2.6L	2588	3.1L	189	4.0L	3950	5.8L	5800
2.6L	2597	3.1L	191	4.0L	3982	5.9L	360
2.6L	2599	3.1L	3137	4.0L	4016	5.9L	361
2.6L	2600	3.2L	194	4.1L	250	6.0L	363
2.6L	2606	3.2L	196	4.2L	255	6.1L	370
2.7L	165	3.2L	198	4.2L	258	6.2L	379
2.7L	167	3.2L	3165	4.2L	4172	6.3L	383
2.7L	294	3.2L	3179	4.2L	4196	6.4L	389
2.7L	2656	3.2L	3200	4.2L	4200	6.4L	390
2.7L	2671	3.2L	3206	4.3L	260	6.4L	391
2.7L	2672	3.3L	185	4.3L	261	6.5L	395
2.7L	2673	3.3L	200	4.3L	262	6.5L	396
2.7L	2675	3.3L	3210	4.3L	265	6.6L	400
2.7L	2688	3.3L	3230	4.3L	4294	6.6L	401
2.7L	2693	3.3L	3275	4.4L	265	6.6L	402
2.7L	2694	3.3L	3294	4.4L	267	6.6L	403
2.7L	2700	3.3L	3300	4.4L	270	6.6L	406
2.8L	170	3.4L	204	4.5L	273	6.7L	409
2.8L	171	3.4L	207	4.6L	281	6.8L	413
2.8L	173	3.4L	3378	4.6L	283	6.8L	415
2.8L	231	3.4L	3400	4.7L	285	6.9L	420
2.8L	2753	3.4L	3431	4.7L	287	6.9L	421
2.8L	2754	3.5L	212	4.7L	289	7.0L	425
2.8L	2771	3.5L	3430	4.8L	290	7.0L	427
2.8L	2788	3.5L	3453	4.8L	292	7.0L	428
2.8L	2792	3.5L	3475	4.8L	294	7.0L	429
2.8L	2793	3.5L	3500	4.9L	300	7.2L	439
2.8L	2800	3.5L	3524	4.9L	301	7.2L	440
2.8L	2827	3.5L	3540	5.0L	302	7.3L	446
2.8L	2849	3.5L	3543	5.0L	304	7.4L	454
2.9L	177	3.6L	221	5.0L	305	7.4L	455
2.9L	179	3.6L	223	5.0L	307	7.5L	455
3.0L	181	3.6L	3562	5.0L	4950	7.5L	460
3.0L	182	3.6L	3590	5.2L	316	7.8L	477
3.0L	183	3.6L	3596	5.2L	318	8.0L	488
3.0L	2954	3.6L	3606	5.3L	326	8.0L	490
3.0L	2959	3.7L	225	5.4L	327	8.1L	496
3.0L	2960	3.7L	226	5.4L	329	8.3L	505
3.0L	2961	3.8L	229	5.4L	330		

Conversions

To Convert	Formula
Millimeters to Inches	MILLIMETERS divided by 25.4 equals INCHES
Inches to Millimeters	INCHES times 25.4 equals MILLIMETERS

DISC (IN)	DISC (MM)	DISC (IN)	DISC (MM)	DISC (IN)	DISC (MM)	DISC (IN)	DISC (MM)
6-1/4	159	8-5/16	211	9-3/8	238	10-7/8	276
6-5/16	160	8-3/8	213	9-7/16	240	11	279
6-1/2	165	8-7/16	214	9-1/2	241	11-1/2	292
6-11/16	170	8-1/2	216	9-5/8	244	11-3/4	298
6-3/4	172	8-5/8	219	9-11/16	246	11-13/16	300
7	178	8-3/4	222	9-3/4	248	11-7/8	302
7-1/8	181	8-13/16	224	9-7/8	248	12	305
7-1/4	184	8-7/8	225	10	254	12-1/4	311
7-3/8	187	9	229	10-1/8	257	12-3/4	324
7-1/2	190	9-1/16	230	10-1/4	260	12-13/16	325
7-7/8	200	9-1/8	232	10-3/8	264	13	330
8	203	9-1/4	235	10-1/2	267	14	356
8-1/4	210	9-5/16	237	10-3/4	273	15	381

To Convert	Formula
Millimeters to Inches	MILLIMETERS divided by 25.4 equals INCHES
Inches to Millimeters	INCHES times 25.4 equals MILLIMETERS

DISC (MM)	DISC (IN)	DISC (MM)	DISC (IN)	DISC (MM)	DISC (IN)	DISC (MM)	DISC (IN)
159	6-1/4	213	8-3/8	241	9-1/2	298	11-3/4
160	6-5/16	214	8-7/16	244	9-5/8	300	11-13/16
165	6-1/2	216	8-1/2	246	9-11/16	302	11-7/8
170	6-11/16	219	8-5/8	248	9-3/4	305	12
172	6-3/4	222	8-3/4	248	9-7/8	311	12-1/4
178	7	224	8-13/16	254	10	324	12-3/4
181	7-1/8	225	8-7/8	257	10-1/8	325	12-13/16
184	7-1/4	229	9	260	10-1/4	330	13
187	7-3/8	230	9-1/16	264	10-3/8	352	13-7/8
190	7-1/2	232	9-1/8	267	10-1/2	356	14
200	7-7/8	235	9-1/4	273	10-3/4	381	15
203	8	237	9-5/16	276	10-7/8	14	356
210	8-1/4	238	9-3/8	279	11	15	381

A white sheet of lined paper with horizontal ruling lines, placed over a background of technical drawings and sketches of mechanical parts. The drawings include various components like gears, shafts, and housings, with some text labels such as "EXEDY", "BSSQ", and "CW122" visible.

A sheet of lined paper with a faint technical drawing of a mechanical part in the background. The drawing includes various components like a central hub, spokes, and a rim, with some parts labeled 'EXEDY' and '6000'. The paper has horizontal lines for writing.

A large white rectangular area with horizontal lines for writing, overlaid on a faint technical drawing of a mechanical component. The drawing includes various parts, bolts, and labels such as 'EXEDY', 'BSSQ', and 'CW122'.

Worldwide Network

● Direct Investment (Production) ● Direct Investment (Sales/Production)

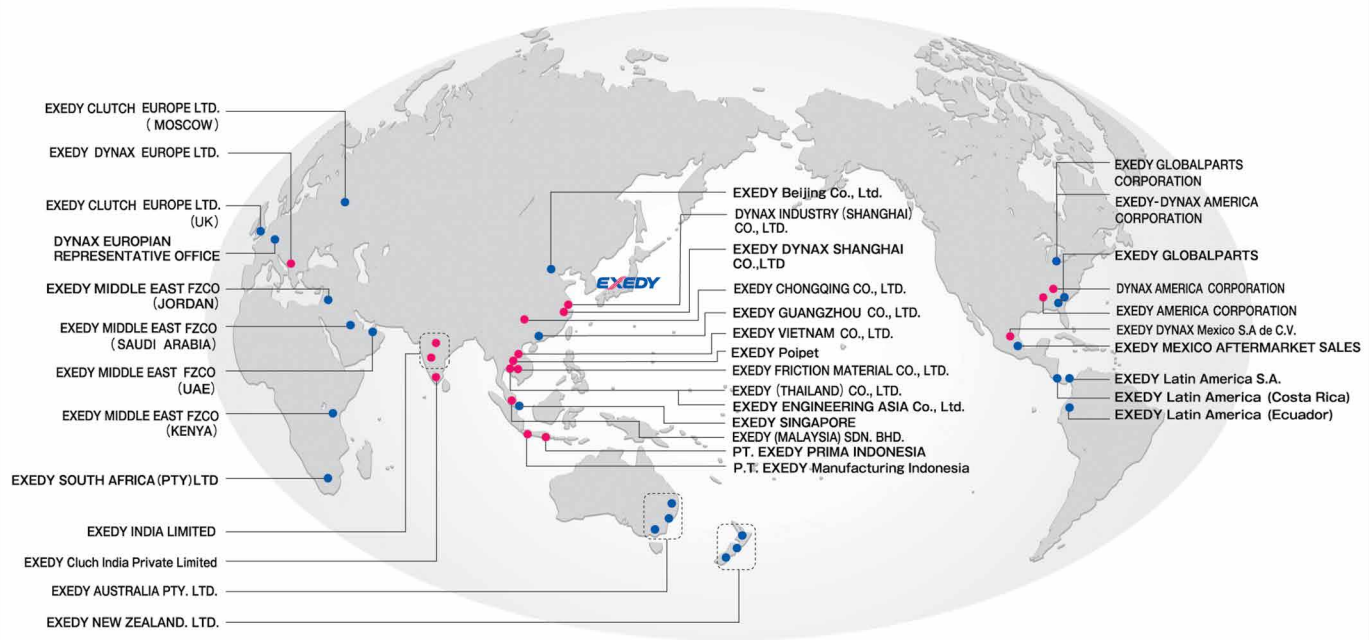

EXEDY GLOBALPARTS CORPORATION
8601 HAGGERTY RD. SOUTH
VAN BUREN TWP., MI 48111

www.exedyusa.com
800.346.6091

TECHNICAL SUPPORT — MON.-FRI. 8:30AM-5:00PM EST
CALL/TEXT INQUIRES TO 734.740.1986