

STAINLESS VALVES

Manley Performance is universally acknowledged as the leading manufacturer of performance and racing valves in the world.

The reason for Manley's overwhelming success is simple: **QUALITY**. We offer the best materials in the industry - exclusive materials our competitors do not possess. Our stems are hard coated with .0002" thick chrome rather than a few millionths of flash. Our hard tips are superior to competitors' puddled stellite which can crack and erode off the stem. Our valve head and underhead shapes have been in the forefront of the quest for improved flow since the late 1960's. And always each Manley valve has been price targeted to specific markets to ensure the best possible value to the customer.

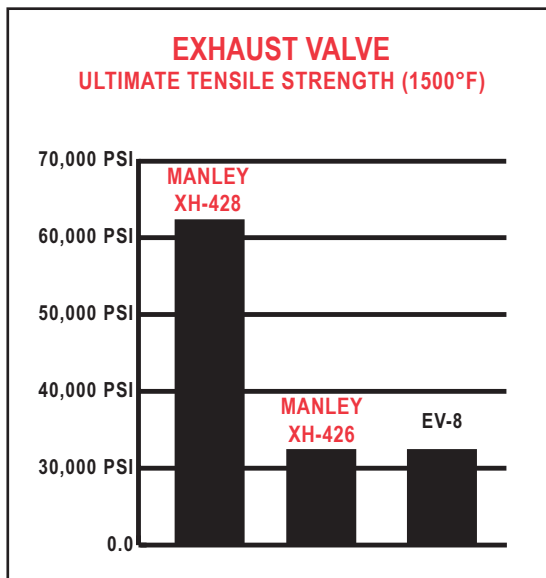

PERFORMANCE & STREET SERIES VALVES

Designed for the enthusiast preparing a stock or mildly modified street engine, or a bracket racer seeking maximum value for his dollar, the Performance or Street Series valves are the perfect choice. These dependable valves are also offered in Street Flo versions providing significant flow gains without head porting. All valves in both these series feature chrome stems, hard tips, swirl polished underhead areas, and fully machined combustion faces.

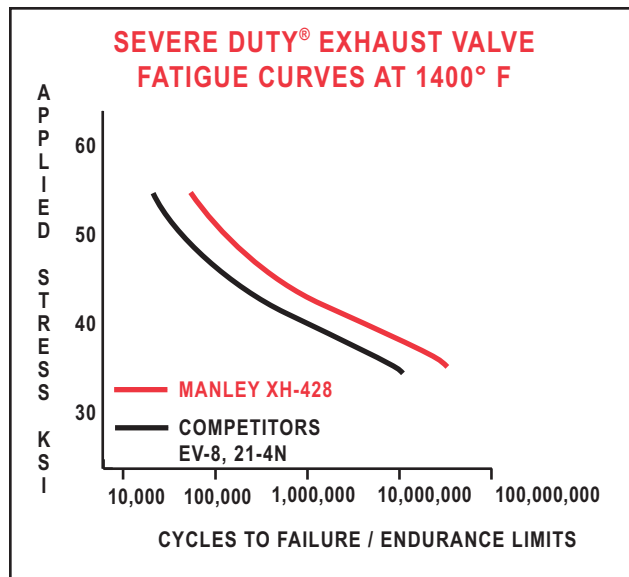

RACE MASTER VALVES

Race Master, and the Pro Flo versions identified as Race Flo valves, are manufactured of XH-426 material for the exhausts and NK-842 for the intakes. This series of valves is targeted at the bracket, drag and oval track racers operating below 8000 rpm - above which engine speed titanium valves are generally required. Any engine builder successfully using EV-8 alloy (21-4N) valves will find in this series of Manley valves a superior piece at a most attractive price. The Ultimate Tensile Strength charts on this page and the next, show the Manley Race Series to be equal to the best that the competitors have to offer.

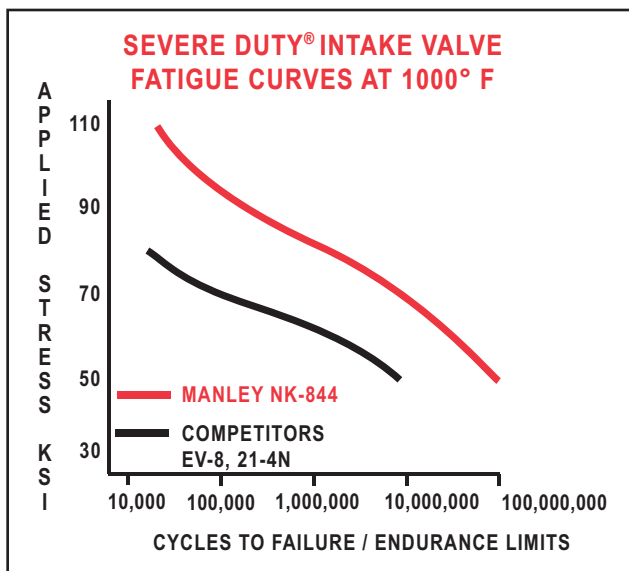

SEVERE DUTY® VALVES

The Severe Duty® series of valves is the Manley signature in the performance and racing industry. Exhaust material XH-428 and intake material NK-844 is offered by no competitor in the world. And no pair of materials show such clear dominance over all others. Ultimate tensile strength of XH-428 at 1500°F is nearly double the competitors' EV-8. At 1000°F the Manley NK-844 displays more than four times the ultimate tensile of the competition's best intake material.

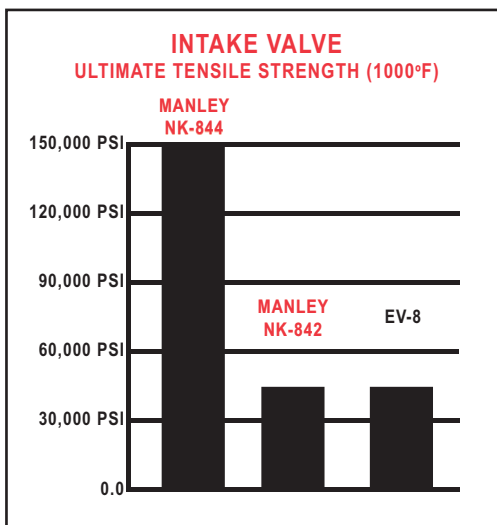

Further proof of the superiority of the Manley Severe Duty® valves is evident in our comprehensive fatigue tests. In normal operation where valve float is non-existent, a valve will experience 20,000 to 25,000 lbs of applied stress. However, when valves bounce on the seat the stress immediately soars to 40,000 to 60,000 lbs. Manley exhaust valves (at 40,000 psi and 1400°F) ran to 100,000,000 (one hundred million) cycles while competitors' offerings failed at 100,000 cycles. That's 1000 times better fatigue life.

EXTREME DUTY VALVES

Top Fuel and Funny Car drag racers, Big Block Chevy marine enthusiasts, and Small Block Chevy restricted carburetor circle track competitors will all benefit by the use of XtremeAlloy exhaust valves. Exotic steel is required simply because of the enormous heat imposed on the exhaust valves in these applications.

The accompanying graph illustrates the complete superiority of our "exotic" steels over our own XH-428 as well as competitor's EV-8.

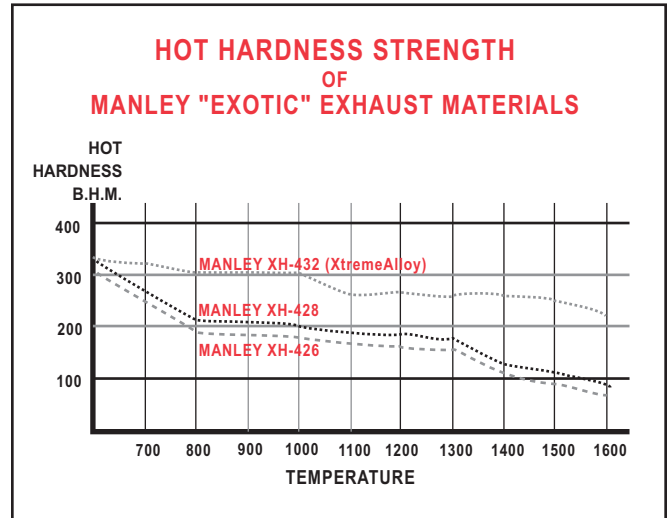

In addition to the vastly superior strength and fatigue characteristics of Manley NK-844, our exclusive intake material exhibits an uncanny ability to resist chordal fractures. In an excellent sealing combustion chamber, the intake valve is actually deformed by the fuel explosion and pushed up into the port. The effect of this continuous deformation on competitors' material eventually is a chordal fracture propagating from the circumference of the valve and quickly becoming a missing pie-shaped piece. Manley NK-844 is the absolute best choice of material to combat disastrous chordal fractures.

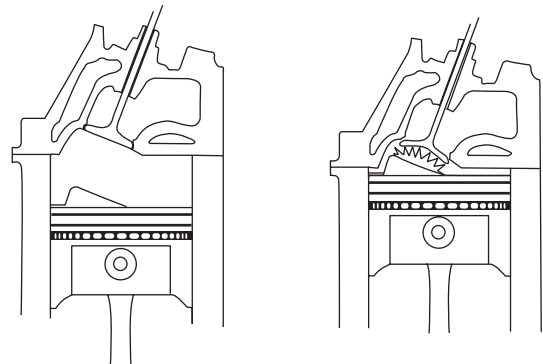

The illustration above shows an intake valve seated in the head with normal shape. The right illustration shows the valve being deformed under high combustion pressure.

STAINLESS VALVES

A Manley Valve For Every Application

Choose from one of five series of stainless valves

PERFORMANCE SERIES

- ▶ Stainless Steel (XH-422 Exhaust and NK-840 Intake)
- ▶ Chrome Stems and Hard Tips
- ▶ Swirl Polished and Fully Machined
- ▶ Stock and .100" Longer Lengths Available



STREET SERIES

- ▶ Stainless Steel (XH-424 Exhaust and NK-841 Intake)
- ▶ Chrome Stems and Hard Tips
- ▶ Swirl Polished and Fully Machined
- ▶ Street Master (Straight Stem) and Street Flo Shapes Available



RACE SERIES

- ▶ Stainless Steel (XH-426 Exhaust and NK-842 Intake)
- ▶ Chrome Stems and Hard Tips
- ▶ Swirl Polished and Fully Machined
- ▶ Race Master (Straight Stem) and Race Flo Shapes Available
- ▶ Recommended Exhaust Valves for Alcohol Engines



SEVERE DUTY® SERIES

- ▶ Superior Stainless for High Temperature Gasoline Engines
- ▶ Exhaust Material XH-428 with Double the Ultimate Tensile Strength (at 1500°F) over the competition
- ▶ Chrome Stems and Hard Tips
- ▶ Swirl Polished and Fully Machined
- ▶ Intake Material NK-844 with 1000 Times Better Fatigue Strength than competitors' offerings



EXTREME DUTY SERIES

- ▶ Top Fuel, Funny Car and Marine Engine Exhaust Valves
- ▶ More Hot Hardness and High Temperature Strength than any competitive offerings
- ▶ Chrome Stems and Hard Tips
- ▶ Swirl Polished and Fully Machined
- ▶ XH-432 XtremeAlloy



EXHAUST VALVE TEMPERATURE RANGE CHART

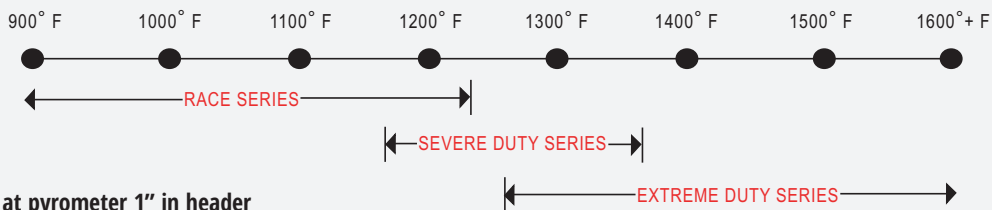

The "Pro Flo" Shape

A Manley Original

- ▶ Up to 40% flow increase in small port OE style cylinder heads
- ▶ Proven performance improvement on the flow bench

Test for: Hot Rod Magazine
 Tests performed by: Edelbrock
 Type of cylinder head: 1969 Camaro

AMOUNT OF NET VALVE LIFT	INTAKE IMPROVEMENT IN FLOW	EXHAUST IMPROVEMENT IN FLOW
.150"	42%	93%
.200"	37%	27%
.250"	25%	23%
.300"	12%	22%
.350"	7%	19%
.400"	5%	14%



Available in Three Series of Valves

Series	"Pro Flo" Designation
Street	Street Flo
Race	Race Flo
Severe Duty	Pro Flo

Stainless Steel & Titanium Valve Buyers Guide

Valve Type	Replacement and Mild Street Performance	Engine Builders Using EV-8 High Perf Street Bracket Racers Oval Track Sportsman Racers	Naturally Aspirated Alcohol Burning Engines	Drag Racing Over 8000 RPM	Offshore Powerboat and Hi Performance Marine	Sprint Car Dirt Late Model
Performance Series	Acceptable					
Street Series	Preferred					
Race Series	Extra Insurance	Acceptable	Preferred Exhaust When Titanium is Not Allowed		Not Recommended	
Severe Duty®		Preferred	Preferred Intake When Titanium is Not Allowed		Required Intake	
Extreme Duty		Preferred with Restricted Carburetor		Top Fuel Funny Car Exhaust Only	Required Exhaust	
Titanium			Preferred	Required Other Than Top Fuel or Funny Car	Race Only	Required

STAINLESS VALVES

VALVES

LS-1 / LS-2 (LS-6 Head) Small Block Chevy

Race Flo / Race Master Valves

- ▶ XH-426 Stainless Exhaust Material
- ▶ Chrome Stems and Hard Tips
- ▶ Intakes are "Pro Flo" for Improved Flow
- ▶ NK-842 Stainless Intake Material
- ▶ Swirl Polished and Machined
- ▶ O.E. Style Radius Keeper Grooves



Part No.	Type	Head Diam.	Stem Diameter	Installed Height	O / A Length	Tip Length	Underhead Angle / Radius	Margin	Seat Width	Top of Head	Wgt / Grams
11361-8	Exh.	1.550	.3136	Stock	4.923	.175	25° x 7/16"	.065	.115	18° Dish	87
11363-8	Exh.	1.575	.3136	Stock	4.923	.175	25° x 7/16"	.065	.115	18° Dish	89
11365-8	Exh.	1.600	.3136	Stock	4.923	.175	25° x 7/16"	.065	.115	18° Dish	91
11360-8	Int.	2.000	.3133	Stock	4.874	.175	Pro Flo: 12° x 3/8"	.050	.095	7° Dish	103
11360H-8	Int.	2.000	.3133	Stock	4.874	.175	Pro Flo: 12° x 3/8"	.050	.095	7° Dish	91
			Hollow Stem								
11362-8	Int.	2.020	.3133	Stock	4.874	.175	Pro Flo: 12° x 3/8"	.050	.095	7° Dish	105
11362H-8	Int.	2.020	.3133	Stock	4.874	.175	Pro Flo: 12° x 3/8"	.050	.095	7° Dish	93
			Hollow Stem								
11390-8	Int.	2.055	.3133	Stock	4.874	.175	Pro Flo: 12° x 3/8"	.050	.095	7° Dish	106
11390H-8	Int.	2.055	.3133	Stock	4.874	.175	Pro Flo: 12° x 3/8"	.050	.095	7° Dish	94
			Hollow Stem								
11398-8	Int.	2.080	.3133	Stock	4.874	.175	Pro Flo: 12° x 3/8"	.050	.095	7° Dish	107
11398H-8	Int.	2.080	.3133	Stock	4.874	.175	Pro Flo: 12° x 3/8"	.050	.095	7° Dish	95
			Hollow Stem								
11350-8	Int.	2.100	.3133	Stock	4.874	.175	Pro Flo: 12° x 3/8"	.050	.095	7° Dish	109
11350H-8	Int.	2.100	.3133	Stock	4.874	.175	Pro Flo: 12° x 3/8"	.050	.095	7° Dish	97
			Hollow Stem								

Severe Duty / Pro Flo Valves

- ▶ XH-428 Stainless Exhaust Material
- ▶ Chrome Stems and Hard Tips
- ▶ Intakes are "Pro Flo" for Improved Flow
- ▶ NK-844 Stainless Intake Material
- ▶ Swirl Polished and Machined
- ▶ O.E. Style Radius Keeper Grooves

Part No.	Type	Head Diam.	Stem Diameter	Installed Height	O / A Length	Tip Length	Underhead Angle / Radius	Margin	Seat Width	Top of Head	Wgt / Grams
11673-8	Exh.	1.550	.3136	Stock	4.923	.175	25° x 7/16"	.065	.115	18° Dish	88
11675-8	Exh.	1.575	.3136	Stock	4.923	.175	25° x 7/16"	.065	.115	18° Dish	90
11677-8	Exh.	1.600	.3136	Stock	4.923	.175	25° x 7/16"	.065	.115	18° Dish	92
11680-8	Int.	2.055	.3133	Stock	4.874	.175	Pro Flo: 12° x 3/8"	.050	.095	7° Dish	107
11680H-8	Int.	2.055	.3133	Stock	4.874	.175	Pro Flo: 12° x 3/8"	.050	.095	7° Dish	95
			Hollow Stem								
11682-8	Int.	2.080	.3133	Stock	4.874	.175	Pro Flo: 12° x 3/8"	.050	.095	7° Dish	108
11682H-8	Int.	2.080	.3133	Stock	4.874	.175	Pro Flo: 12° x 3/8"	.050	.095	7° Dish	96
			Hollow Stem								
11684-8	Int.	2.100	.3133	Stock	4.874	.175	Pro Flo: 12° x 3/8"	.050	.095	7° Dish	110
11684H-8	Int.	2.100	.3133	Stock	4.874	.175	Pro Flo: 12° x 3/8"	.050	.095	7° Dish	98
			Hollow Stem								

Extreme Duty Exhaust Valves

- ▶ XH-432 XtremeAlloy Material
- ▶ Chrome Stems and Hard Tips
- ▶ Swirl Polished and Machined
- ▶ O.E. Style Radius Keeper Grooves

Part No.	Type	Head Diam.	Stem Diameter	Installed Height	O / A Length	Tip Length	Underhead Angle / Radius	Margin	Seat Width	Top of Head	Wgt / Grams
11681-8	Exh.	1.575	.3136	Stock	4.923	.175	25° x 7/16"	.065	.115	18° Dish	95
11683-8	Exh.	1.600	.3136	Stock	4.923	.175	25° x 7/16"	.065	.115	18° Dish	97

LS-3 / L-99 (L-92 Head) Small Block Chevy

Race Flo / Race Master Valves

- ▶ XH-426 Stainless Exhaust Material
- ▶ Chrome Stems and Hard Tips
- ▶ Intakes are "Pro Flo" for Improved Flow
- ▶ NK-842 Stainless Intake Material
- ▶ Swirl Polished and Machined
- ▶ O.E. Style Radius Keeper Grooves



Part No.	Type	Head Diam.	Stem Diameter	Installed Height	O / A Length	Tip Length	Underhead Angle / Radius	Margin	Seat Width	Top of Head	Wgt / Grams
11621-8	Exh.	1.590	.3136	Stock	4.923	.160	25° x 7/16"	.070	.115	18° Dish	93
12353-8	Exh.	1.600	.3136	.300 Longer	5.215	.160	25° x 7/16"	.065	.115	18° Dish	95
11620-8	Int.	2.165	.3133	Stock	4.900	.160	Pro Flo: 12° x 3/8"	.055	.100	7° Dish	117
11620H-8	Int.	2.165	.3133	Stock	4.900	.160	Pro Flo: 12° x 3/8"	.055	.100	7° Dish	108
			Hollow Stem								
12350-8	Int.	2.165	.3133	.300 Longer	5.200	.160	Pro Flo: 12° x 3/8"	.055	.100	7° Dish	119
12350H-8	Int.	2.165	.3133	.300 Longer	5.200	.160	Pro Flo: 12° x 3/8"	.055	.100	7° Dish	110
			Hollow Stem								

Severe Duty / Pro Flo Valves

- ▶ XH-428 Stainless Exhaust Material
- ▶ Chrome Stems and Hard Tips
- ▶ Intakes are "Pro Flo" for Improved Flow
- ▶ NK-844 Stainless Intake Material
- ▶ Swirl Polished and Machined
- ▶ O.E. Style Radius Keeper Grooves

Part No.	Type	Head Diam.	Stem Diameter	Installed Height	O / A Length	Tip Length	Underhead Angle / Radius	Margin	Seat Width	Top of Head	Wgt / Grams
11661-8	Exh.	1.590	.3136	Stock	4.923	.160	25° x 7/16"	.070	.115	18° Dish	94
12355-8	Exh.	1.600	.3136	.300 Longer	5.215	.160	25° x 7/16"	.065	.115	18° Dish	96
11686-8	Int.	2.165	.3133	Stock	4.900	.160	Pro Flo: 12° x 3/8"	.055	.100	7° Dish	118
11686H-8	Int.	2.165	.3133	Stock	4.900	.160	Pro Flo: 12° x 3/8"	.055	.100	7° Dish	109
			Hollow Stem								
12354-8	Int.	2.165	.3133	.300 Longer	5.200	.160	Pro Flo: 12° x 3/8"	.055	.100	7° Dish	120
12354H-8	Int.	2.165	.3133	.300 Longer	5.200	.160	Pro Flo: 12° x 3/8"	.055	.100	7° Dish	111
			Hollow Stem								

Extreme Duty Exhaust Valves

- ▶ XH-432 XtremeAlloy Material
- ▶ Swirl Polished and Machined
- ▶ Chrome Stems and Hard Tips
- ▶ O.E. Style Radius Keeper Grooves

Part No.	Type	Head Diam.	Stem Diameter	Installed Height	O / A Length	Tip Length	Underhead Angle / Radius	Margin	Seat Width	Top of Head	Wgt / Grams
11685-8	Exh.	1.590	.3136	Stock	4.923	.160	25° x 7/16"	.070	.115	18° Dish	94
12357-8	Exh.	1.600	.3136	.300 Longer	5.215	.160	25° x 7/16"	.065	.115	18° Dish	96

STAINLESS VALVES

VALVES

LS-7 Small Block Chevy

Severe Duty / Pro Flo / Race Master Valves

- ▶ Chrome Stems and Hard Tips
- ▶ Intakes are "Pro Flo" for Improved Flow
- ▶ Swirl Polished and Machined
- ▶ O.E. Style Radius Keeper Grooves



Part No.	Type	Head Diam.	Stem Diameter	Installed Height	O / A Length	Tip Length	Underhead Angle / Radius	Margin	Seat Width	Top of Head	Wgt / Grams
RACE MASTER											
11689-8	Exh.	1.615	.3136	Stock	5.230	.290	25° x 7/16"	.075	.100	18° Dish	98
SEVERE DUTY / PRO FLO VALVES											
11679-8	Exh.	1.615	.3136	Stock	5.230	.290	25° x 7/16"	.075	.100	18° Dish	103
11688-8	Int.	2.205	.3133	Stock	5.200	.300	Pro Flo: 12° x 3/8"	.050	.100	7° Dish	120
11688H-8	Int.	2.205	.3133	Stock	5.200	.300	Pro Flo: 12° x 3/8"	.050	.100	7° Dish	110
Hollow Stem											

Extreme Duty Exhaust Valves

- ▶ XH-432 XtremeAlloy Material
- ▶ Swirl Polished and Machined
- ▶ Chrome Stems and Hard Tips
- ▶ O.E. Style Radius Keeper Grooves

Part No.	Type	Head Diam.	Stem Diameter	Installed Height	O / A Length	Tip Length	Underhead Angle / Radius	Margin	Seat Width	Top of Head	Wgt / Grams
11687-8	Exh.	1.615	.3136	Stock	5.230	.290	25° x 7/16"	.075	.100	18° Dish	103

Trick Flow Specialties (TFS) Chevy LS Cylinder Heads and Valve Application Chart

TFS Head	Int. Head Diam.	Manley Intake P/N's		Exh Head Diam.	Manley Exhaust P/N's		
		Race Series	Severe Duty		Race Series	Severe Duty	Xtreme Duty
LS1 205	2.000"	11360, 11360H	-----	1.575"	11363	11675	11681
LS1 215, 220	2.040"	Custom from Gen II	Custom from Gen II	1.575"	11363	11675	11681
LS 225, LS2 220	2.055"	11390, 11390H	11680, 11680H	1.575"	11363	11675	11681
LS 235	2.080"	11398, 11398H	11682, 11682H	1.600"	11365	11677	11683
LS 245	2.100"	11350, 11350H	11684, 11684H	1.600"	11365	11677	11683
LS3	2.165"	12350, 12350H	12354, 12354H	1.600"	12353	12355	12357
LS7	2.200"	-----	11688, 11688H	1.600"	12353	12355	12357

In the case where multiple part numbers options exist, choose from either our Race Series, Severe Duty or Xtreme Duty material depending on your application.
Note: "H" suffix indicates hollow stem

L83 5.3L Small Block Chevy 2014-Up

Race Flo / Race Master & Pro Flo / Severe Duty Valves

- ▶ Chrome Stems and Hard Tips
- ▶ Swirl Polished and Machined
- ▶ Intakes are "Pro Flo" for Improved Flow
- ▶ O.E. Style Radius Keeper Grooves

Part No.	Type	Head Diam.	Stem Diameter	Installed Height	O / A Length	Tip Length	Underhead Angle / Radius	Margin	Seat Width	Top of Head	Wgt / Grams
RACE FLO / RACE MASTER VALVES											
12359-8	Exh.	1.560	.3136	Stock	5.208	.160	25° x 7/16"	.065	.110	18°	92
12356-8*	Int.	1.930	.3133	Stock	5.232	.160	Pro Flo 12° x 3/8"	.050	.100	7°	112
PRO FLO / SEVERE DUTY											
12361-8	Exh.	1.560	.3136	Stock	5.208	.160	25° x 7/16"	.065	.110	18°	93
12358-8*	Int.	1.930	.3133	Stock	5.232	.160	Pro Flo 12° x 3/8"	.050	.100	7°	113

* Valves 12356 and 12358 have a back cut of .050" x 30°

Extreme Duty Exhaust Valves

- ▶ XH-432 XtremeAlloy Material
- ▶ Chrome Stems and Hard Tips
- ▶ Swirl Polished and Machined
- ▶ O.E. Style Radius Keeper Grooves

Part No.	Type	Head Diam.	Stem Diameter	Installed Height	O / A Length	Tip Length	Underhead Angle / Radius	Margin	Seat Width	Top of Head	Wgt / Grams
12363-8	Exh.	1.560	.3136	Stock	5.208	.160	25° x 7/16"	.065	.110	18°	98

LT1 6.2L Small Block Chevy 2014-Up

Race Flo / Race Master & Pro Flo / Severe Duty Valves

- ▶ Chrome Stems and Hard Tips
- ▶ Swirl Polished and Machined
- ▶ Intakes are "Pro Flo" for Improved Flow
- ▶ O.E. Style Radius Keeper Grooves



Part No.	Type	Head Diameter	Stem Diameter	Installed Height	O/A Length	Tip Length	Underhead Angle/Radius	Margin	Seat Width	Top of Head	Wgt/ Grams
RACE FLO / RACE MASTER VALVES											
12345-8	Exh.	1.590	.3136	Stock	5.205	.160	25° x 7/16"	.075	.100	18° Dish	97
12348-8*	Int.	2.120	.3133	Stock	5.253	.170	Pro Flo 12° x 3/8"	.050	.070	7° Dish	124
PRO FLO / SEVERE DUTY											
12347-8	Exh.	1.590	.3136	Stock	5.205	.160	25° x 7/16"	.075	.100	18° Dish	97
12352-8*	Int.	2.120	.3133	Stock	5.253	.170	Pro Flo 12° x 3/8"	.050	.070	7° Dish	124

* Valves 12348 and 12352 have a back cut of .075" x 30°

Extreme Duty Exhaust Valves

- ▶ XH-432 XtremeAlloy Material
- ▶ Chrome Stems and Hard Tips
- ▶ Swirl Polished and Machined
- ▶ O.E. Style Radius Keeper Grooves

Part No.	Type	Head Diam.	Stem Diameter	Installed Height	O / A Length	Tip Length	Underhead Angle / Radius	Margin	Seat Width	Top of Head	Wgt / Grams
12349-8	Exh.	1.590	.3136	Stock	5.205	.160	25° x 7/16"	.075	.100	18° Dish	102

STAINLESS VALVES

VALVES

Small Block Chevrolet

Budget Replacement Valves

- ▶ XH-422 Stainless Exhaust Material
- ▶ NK-840 Stainless Intake Material
- ▶ Chrome Stems and Hard Tips
- ▶ Original Underhead Shapes and Finishes



Part No.	Type	Head Diameter	Stem Diameter	Installed Height	O / A Length	Tip Length	Underhead Angle / Radius	Margin	Seat Width	Top of Head	Wgt / Grams
10077-8	Exh.	1.500	.3415	Stock	4.920	.290	0° x 11/32"	.100	.150	Dimple	106
10649-8	Exh.	1.600	.3415	Stock	4.910	.290	0° x 1/2"	.070	.150	Dimple	105
10476-8	Int.	1.940	.3415	Stock	4.880	.250	10° x 3/8"	.065	.125	Dimple	116
10650-8	Int.	2.020	.3415	Stock	4.880	.260	10° x 3/8"	.060	.120	Flat Face	117

Small Block Chevrolet

Budget Performance Valves

- ▶ XH-422 Stainless Exhaust Material
- ▶ NK-840 Stainless Intake Material
- ▶ Chrome Stems and Hard Tips
- ▶ Swirl Polished and Fully Machined



Part No.	Type	Head Diameter	Stem Diameter	Installed Height	O / A Length	Tip Length	Underhead Angle / Radius	Margin	Seat Width	Top of Head	Wgt / Grams
10577-8	Exh.	1.500	.3415	Stock	4.911	.250	15° x 1/2"	.060	.100	10° Dish	96
10549-8	Exh.	1.600	.3415	Stock	4.911	.250	15° x 1/2"	.060	.100	10° Dish	101
10551-8	Exh.	1.600	.3415	.100 Longer	5.011	.250	15° x 1/2"	.060	.100	10° Dish	103
10548-8	Int.	1.900	.3415	Stock	4.911	.250	10° x 3/8"	.050	.080	6° Dish	105
10576-8	Int.	1.940	.3415	Stock	4.911	.250	10° x 3/8"	.050	.080	6° Dish	105
10550-8	Int.	2.020	.3415	Stock	4.911	.250	10° x 3/8"	.050	.080	6° Dish	109
10552-8	Int.	2.020	.3415	.100 Longer	5.011	.250	10° x 3/8"	.050	.080	6° Dish	111
10554-8	Int.	2.055	.3415	Stock	4.911	.250	10° x 3/8"	.050	.080	6° Dish	110
10556-8	Int.	2.055	.3415	.100 Longer	5.011	.250	10° x 3/8"	.050	.080	6° Dish	112

Small Block Chevrolet Street Flo Valves

- ▶ XH-424 Stainless Exhaust Material
- ▶ Chrome Stems and Hard Tips
- ▶ Increased Flow with "Pro Flo" Underhead
- ▶ NK-841 Stainless Intake Material
- ▶ Swirl Polished and Fully Machined



Part No.	Type	Head Diameter	Stem Diameter	Installed Height	O / A Length	Tip Length	Underhead Angle / Radius	Margin	Seat Width	Top of Head	Wgt / Grams
10721-8	Exh.	1.500	.3415	Stock	4.911	.250	Pro Flo: 12° x 3/8"	.060	.100	7° Dish	89
10705-8	Exh.	1.500	.3415	.100 Longer	5.035	.290	Pro Flo: 15° x 1/2"	.060	.100	9° Dish	93
10765-8	Exh.	1.600	.3415	Stock	4.911	.250	Pro Flo: 12° x 3/8"	.060	.100	7° Dish	94
10745-8	Exh.	1.600	.3415	.100 Longer	5.065	.290	Pro Flo: 15° x 1/2"	.090	.100	9° Dish	95
10755-8	Exh.	1.600	.3415	.200 Longer	5.165	.290	Pro Flo: 15° x 1/2"	.090	.100	9° Dish	96
10797-8	Exh.	1.625	.3415	.100 Longer	5.065	.290	Pro Flo: 15° x 1/2"	.090	.100	9° Dish	98
10722-8	Int.	1.940	.3415	Stock	4.911	.250	Pro Flo: 12° x 3/8"	.050	.080	5° Dish	107
10724-8	Int.	1.940	.3415	.100 Longer	5.025	.290	Pro Flo: 12° x 3/8"	.050	.080	7° Dish	108
10764-8	Int.	2.000	.3415	Stock	4.911	.250	Pro Flo: 10° x 3/8"	.050	.080	6° Dish	108
10766-8	Int.	2.020	.3415	Stock	4.911	.250	Pro Flo: 12° x 3/8"	.050	.080	5° Dish	109
10796-8	Int.	2.020	.3415	.100 Longer	5.040	.290	Pro Flo: 12° x 3/8"	.065	.080	7° Dish	115
10798-8	Int.	2.020	.3415	.200 Longer	5.125	.290	Pro Flo: 12° x 3/8"	.050	.080	7° Dish	116
10768-8	Int.	2.055	.3415	Stock	4.911	.250	Pro Flo: 12° x 3/8"	.050	.080	5° Dish	115
10746-8	Int.	2.055	.3415	.100 Longer	5.040	.290	Pro Flo: 12° x 3/8"	.065	.080	7° Dish	116
10760-8	Int.	2.080	.3415	.100 Longer	5.040	.290	Pro Flo: 12° x 3/8"	.065	.080	7° Dish	117
10762-8	Int.	2.080	.3415	.200 Longer	5.140	.290	Pro Flo: 12° x 3/8"	.065	.080	7° Dish	118
10770-8	Int.	2.100	.3415	.100 Longer	5.040	.290	Pro Flo: 12° x 3/8"	.065	.080	7° Dish	118

The 10764 will work on the new Chevy Vortec Bowtie cylinder head casting numbers 25534351C and 25534371C.

Small Block Chevrolet Street Master Valves

- ▶ XH-424 Stainless Exhaust Material
- ▶ Chrome Stems and Hard Tips
- ▶ Straight Stems
- ▶ NK-841 Stainless Intake Material
- ▶ Swirl Polished and Fully Machined



Part No.	Type	Head Diameter	Stem Diameter	Installed Height	O / A Length	Tip Length	Underhead Angle / Radius	Margin	Seat Width	Top of Head	Wgt / Grams
10777-8	Exh.	1.500	.3415	Stock	4.911	.250	15° x 1/2"	.060	.100	10° Dish	96
10747-8	Exh.	1.560	.3415	Stock	4.911	.250	15° x 1/2"	.060	.100	10° Dish	99
10749-8	Exh.	1.600	.3415	Stock	4.911	.250	15° x 1/2"	.060	.100	10° Dish	101
10751-8	Exh.	1.600	.3415	.100 Longer	5.011	.250	15° x 1/2"	.060	.100	10° Dish	103
10776-8	Int.	1.940	.3415	Stock	4.911	.250	10° x 3/8"	.050	.080	6° Dish	105
10750-8	Int.	2.020	.3415	Stock	4.911	.250	10° x 3/8"	.050	.080	6° Dish	109
10752-8	Int.	2.020	.3415	.100 Longer	5.011	.250	10° x 3/8"	.050	.080	6° Dish	111
10754-8	Int.	2.055	.3415	Stock	4.911	.250	10° x 3/8"	.050	.080	6° Dish	110
10756-8	Int.	2.055	.3415	.100 Longer	5.011	.250	10° x 3/8"	.050	.080	6° Dish	112

The 10747 will work on the new Chevy Vortec Bowtie cylinder head casting numbers 25534351C and 25534371C.

STAINLESS VALVES

VALVES

Small Block Chevrolet Race Flo Valves

- ▶ XH-426 Stainless Exhaust Material
- ▶ NK-842 Stainless Intake Material
- ▶ Chrome Stems and Hard Tips
- ▶ Swirl Polished and Fully Machined
- ▶ Increased Flow with "Pro Flo" Underhead



Part No.	Type	Head Diameter	Stem Diameter	Installed Height	O / A Length	Tip Length	Underhead Angle / Radius	Margin	Seat Width	Top of Head	Wgt / Grams
11521-8	Exh.	1.500	.3415	Stock	4.911	.250	Pro Flo: 12° x 3/8"	.060	.100	7° Dish	89
11505-8	Exh.	1.500	.3415	.100 Longer	5.035	.290	Pro Flo: 15° x 1/2"	.060	.100	9° Dish	93
11501-8	Exh.	1.560	.3415	Stock	4.911	.250	Pro Flo: 12° x 3/8"	.060	.100	7° Dish	91
11565-8	Exh.	1.600	.3415	Stock	4.911	.250	Pro Flo: 12° x 3/8"	.060	.100	7° Dish	94
11545-8	Exh.	1.600	.3415	.100 Longer	5.065	.290	Pro Flo: 15° x 1/2"	.090	.100	9° Dish	95
11555-8	Exh.	1.600	.3415	.200 Longer	5.165	.290	Pro Flo: 15° x 1/2"	.090	.100	9° Dish	96
11559-8	Exh.	1.600	.3415	.300 Longer	5.265	.290	Pro Flo: 15° x 1/2"	.090	.100	9° Dish	97
11797-8	Exh.	1.625	.3415	.100 Longer	5.065	.290	Pro Flo: 15° x 1/2"	.090	.100	9° Dish	98
11799-8	Exh.	1.625	.3415	.200 Longer	5.165	.290	Pro Flo: 15° x 1/2"	.090	.100	9° Dish	99
11506-8	Int.	1.840	.3415	Stock	4.911	.250	Pro Flo: 10° x 3/8"	.060	.080	5° Dish	104
11522-8	Int.	1.940	.3415	Stock	4.911	.250	Pro Flo: 10° x 3/8"	.050	.080	5° Dish	107
11356-8	Int.	1.940	.3415	.100 Longer	5.040	.290	Pro Flo: 12° x 3/8"	.050	.100	7° Dish	108
11500-8	Int.	2.000	.3415	Stock	4.911	.250	Pro Flo: 12° x 3/8"	.050	.080	7° Dish	109
11566-8	Int.	2.020	.3415	Stock	4.911	.250	Pro Flo: 12° x 3/8"	.050	.080	5° Dish	113
11796-8	Int.	2.020	.3415	.100 Longer	5.040	.290	Pro Flo: 12° x 3/8"	.065	.080	7° Dish	115
11798-8	Int.	2.020	.3415	.200 Longer	5.125	.290	Pro Flo: 12° x 3/8"	.050	.080	7° Dish	116
11568-8	Int.	2.055	.3415	Stock	4.911	.250	Pro Flo: 12° x 3/8"	.050	.080	5° Dish	115
11546-8	Int.	2.055	.3415	.100 Longer	5.040	.290	Pro Flo: 12° x 3/8"	.065	.080	7° Dish	116
11552-8	Int.	2.055	.3415	.200 Longer	5.140	.290	Pro Flo: 12° x 3/8"	.065	.080	7° Dish	117
11556-8	Int.	2.055	.3415	.300 Longer	5.240	.290	Pro Flo: 12° x 3/8"	.065	.080	7° Dish	118
11558-8	Int.	2.080	.3415	Stock	4.940	.290	Pro Flo: 12° x 3/8"	.065	.080	7° Dish	115
11560-8	Int.	2.080	.3415	.100 Longer	5.040	.290	Pro Flo: 12° x 3/8"	.065	.080	7° Dish	117
11564-8	Int.	2.080	.3415	.200 Longer	5.140	.290	Pro Flo: 12° x 3/8"	.065	.080	7° Dish	118
11574-8	Int.	2.080	.3415	.300 Longer	5.240	.290	Pro Flo: 12° x 3/8"	.065	.080	7° Dish	119
11576-8	Int.	2.100	.3415	.100 Longer	5.040	.290	Pro Flo: 12° x 3/8"	.065	.080	7° Dish	118
11584-8	Int.	2.100	.3415	.200 Longer	5.140	.290	Pro Flo: 12° x 3/8"	.065	.080	7° Dish	119
11594-8	Int.	2.100	.3415	.300 Longer	5.240	.290	Pro Flo: 12° x 3/8"	.065	.080	7° Dish	120
11774-8	Int.	2.125	.3415	.100 Longer	5.040	.290	Pro Flo: 12° x 3/8"	.050	.080	7° Dish	119
11776-8	Int.	2.125	.3415	.200 Longer	5.140	.290	Pro Flo: 12° x 3/8"	.050	.080	7° Dish	120
11778-8	Int.	2.125	.3415	.300 Longer	5.240	.290	Pro Flo: 12° x 3/8"	.050	.080	7° Dish	121

Exhaust valve P/N's 11501, 11521, 11565, and intake valve P/N's 11500, 11522, 11566, and 11568 have a Pro Flo start of 1.400" from the head. All others have a Pro Flo start of 1.600" from the head.

Need a different length? Head diameter not listed? Prefer a BeadLoc® groove?
See pages 42 & 43 for Gen II blanks to construct a valve to your exact specifications.

Small Block Chevrolet Race Master Valves

- ▶ XH-426 Stainless Exhaust Material
- ▶ NK-842 Stainless Intake Material
- ▶ Chrome Stems and Hard Tips
- ▶ Swirl Polished and Fully Machined
- ▶ Straight Stems



Part No.	Type	Head Diameter	Stem Diameter	Installed Height	O / A Length	Tip Length	Underhead Angle / Radius	Margin	Seat Width	Top of Head	Wgt / Grams
11861-8	Exh.	1.500	.3415	Stock	4.951	.290	15° x 1/2"	.060	.100	9° Dish	96
11301-8	Exh.	1.500	.3415	.100 Longer	5.065	.290	15° x 1/2"	.090	.100	9° Dish	103
11863-8	Exh.	1.600	.3415	Stock	4.951	.290	15° x 1/2"	.060	.100	9° Dish	102
11877-8	Exh.	1.600	.3415	.100 Longer	5.065	.290	15° x 1/2"	.090	.100	9° Dish	109
11321-8	Exh.	1.600	.3415	.200 Longer	5.165	.290	15° x 1/2"	.090	.100	9° Dish	110
11323-8	Exh.	1.600	.3415	.300 Longer	5.265	.290	15° x 1/2"	.090	.100	9° Dish	111
11325-8	Exh.	1.600	.3415	.400 Longer	5.365	.290	15° x 1/2"	.090	.100	9° Dish	112
11327-8	Exh.	1.600	.3415	.500 Longer	5.465	.290	15° x 1/2"	.090	.100	9° Dish	113
11329-8	Exh.	1.625	.3415	Stock	4.965	.290	15° x 1/2"	.090	.100	9° Dish	103
11879-8	Exh.	1.625	.3415	.100 Longer	5.065	.290	15° x 1/2"	.090	.100	9° Dish	110
11331-8	Exh.	1.625	.3415	.200 Longer	5.165	.290	15° x 1/2"	.090	.100	9° Dish	112
11333-8	Exh.	1.625	.3415	.300 Longer	5.265	.290	15° x 1/2"	.090	.100	9° Dish	114
11860-8	Int.	1.940	.3415	Stock	4.951	.290	10° x 3/8"	.050	.080	5° Dish	109
11300-8	Int.	1.940	.3415	.100 Longer	5.040	.290	10° x 3/8"	.050	.080	5° Dish	111
11864-8	Int.	2.020	.3415	Stock	4.951	.290	10° x 3/8"	.050	.080	5° Dish	114
11318-8	Int.	2.020	.3415	.100 Longer	5.040	.290	10° x 3/8"	.050	.080	5° Dish	116
11316-8	Int.	2.020	.3415	.200 Longer	5.140	.290	12° x 3/8"	.065	.080	7° Dish	122
11806-8	Int.	2.055	.3415	Stock	4.940	.290	12° x 3/8"	.065	.080	7° Dish	118
11810-8	Int.	2.055	.3415	.100 Longer	5.040	.290	12° x 3/8"	.065	.080	7° Dish	120
11808-8	Int.	2.080	.3415	Stock	4.940	.290	12° x 3/8"	.065	.080	7° Dish	124
11812-8	Int.	2.080	.3415	.100 Longer	5.040	.290	12° x 3/8"	.065	.080	7° Dish	126
11320-8	Int.	2.080	.3415	.200 Longer	5.140	.290	12° x 3/8"	.065	.080	7° Dish	127
11322-8	Int.	2.080	.3415	.300 Longer	5.240	.290	12° x 3/8"	.065	.080	7° Dish	129
11324-8	Int.	2.080	.3415	.400 Longer	5.340	.290	12° x 3/8"	.065	.080	7° Dish	131
11326-8	Int.	2.080	.3415	.500 Longer	5.440	.290	12° x 3/8"	.065	.080	7° Dish	133
11328-8	Int.	2.100	.3415	.100 Longer	5.040	.290	12° x 3/8"	.065	.080	7° Dish	127
11330-8	Int.	2.100	.3415	.200 Longer	5.140	.290	12° x 3/8"	.065	.080	7° Dish	128
11332-8	Int.	2.100	.3415	.300 Longer	5.240	.290	12° x 3/8"	.065	.080	7° Dish	129
11334-8	Int.	2.100	.3415	.400 Longer	5.340	.290	12° x 3/8"	.065	.080	7° Dish	132
11336-8	Int.	2.100	.3415	.500 Longer	5.440	.290	12° x 3/8"	.065	.080	7° Dish	134
11340-8	Int.	2.125	.3415	.100 Longer	5.040	.290	12° x 3/8"	.065	.080	7° Dish	130
11342-8	Int.	2.125	.3415	.200 Longer	5.140	.290	12° x 3/8"	.065	.080	7° Dish	132
11344-8	Int.	2.125	.3415	.300 Longer	5.240	.290	12° x 3/8"	.065	.080	7° Dish	134
11346-8	Int.	2.125	.3415	.400 Longer	5.340	.290	12° x 3/8"	.065	.080	7° Dish	136
11348-8	Int.	2.125	.3415	.500 Longer	5.440	.290	12° x 3/8"	.065	.080	7° Dish	138

Need a different length? Head diameter not listed? Prefer a BeadLoc® groove?
See pages 42 & 43 for Gen II blanks to construct a valve to your exact specifications.

STAINLESS VALVES

VALVES

Small Block Chevrolet

AFR 180cc, 190cc, 195cc, 210cc, 220cc, 227cc, 235cc, 245cc Series Cylinder Heads

Race Flo / Race Master & Pro Flo / Severe Duty Valves

- ▶ Lightweight 8mm stems
- ▶ LS (.060" single radius) style keeper grooves

Use Manley valve lock P/N 13098-16 (7°) or 13153-16 (10°) depending on your spring/retainer choice. Manley stem sizes are .3136" (exh.) and .3133" (int.) respectively. AFR heads have guides sized to .3147" (nominal). Manley strongly recommends that all guides be checked and correctly sized (machine work required) for the Manley valve stem sizes listed to achieve the proper clearances. We can also build any of these exhaust valves from our Extreme Duty valve P/N 11275, found on page 42.



Part No.	Type	Head Diameter	Stem Diameter	Installed Height	O / A Length	Tip Length	Underhead Angle / Radius	Margin	Seat Width	Top of Head	Wgt / Grams
RACE FLO / RACE MASTER VALVES											
12301-8	Exh.	1.600	.3136	Stock	4.950	.260	25° x 7/16"	.070	.100	18° Dish	94
12303-8	Exh.	1.600	.3136	.100 Longer	5.050	.260	25° x 7/16"	.070	.100	18° Dish	95
12300-8	Int.	2.020	.3133	Stock	4.935	.260	Pro Flo 12° x 3/8"	.055	.100	7° Dish	108
12302-8	Int.	2.020	.3133	.100 Longer	5.035	.260	Pro Flo 12° x 3/8"	.055	.100	7° Dish	110
12304-8	Int.	2.050	.3133	Stock	4.935	.260	Pro Flo 12° x 3/8"	.055	.100	7° Dish	112
12306-8	Int.	2.050	.3133	.100 Longer	5.035	.260	Pro Flo 12° x 3/8"	.055	.100	7° Dish	112
12308-8	Int.	2.080	.3133	Stock	4.935	.260	Pro Flo 12° x 3/8"	.055	.100	7° Dish	113
12310-8	Int.	2.080	.3133	.100 Longer	5.035	.260	Pro Flo 12° x 3/8"	.055	.100	7° Dish	114
12312-8	Int.	2.100	.3133	.100 Longer	5.035	.260	Pro Flo 12° x 3/8"	.055	.100	7° Dish	115
PRO FLO / SEVERE DUTY VALVES											
12335-8	Exh.	1.600	.3136	Stock	4.950	.260	25° x 7/16"	.070	.100	18° Dish	94
12337-8	Exh.	1.600	.3136	.100 Longer	5.050	.260	25° x 7/16"	.070	.100	18° Dish	95
12334-8	Int.	2.080	.3133	Stock	4.935	.260	Pro Flo 12° x 3/8"	.055	.100	7° Dish	113
12336-8	Int.	2.080	.3133	.100 Longer	5.035	.260	Pro Flo 12° x 3/8"	.055	.100	7° Dish	114
12338-8	Int.	2.100	.3133	.100 Longer	5.035	.260	Pro Flo 12° x 3/8"	.055	.100	7° Dish	115
12346-8	Int.	2.125	.3133	.100 Longer	5.035	.260	Pro Flo 12° x 3/8"	.055	.100	7° Dish	117

Small Block Chevrolet

Race Master Valves 5/16" (.311") Stem

- ▶ No Need for Inserted Tips or Wear Caps
- ▶ Chrome Stems and Hard Tips
- ▶ Swirl Polished and Fully Machined
- ▶ Thin Stem for Increased Flow and Light Weight

These .311" stem valves are ONLY available with Bead Loc® keeper grooves. Bead Loc® valve locks are REQUIRED.



Part No.	Type	Head Diameter	Stem Diameter	Installed Height	O / A Length	Tip Length	Underhead Angle / Radius	Margin	Seat Width	Top of Head	Wgt / Grams
11305-8	Exh.	1.600	.3110	.100 Longer	5.040	.290	15° x 1/2"	.080	.100	9° Dish	94
11319-8	Exh.	1.600	.3110	.200 Longer	5.140	.290	15° x 1/2"	.080	.100	9° Dish	95
11335-8	Exh.	1.600	.3110	.300 Longer	5.240	.290	15° x 1/2"	.080	.100	9° Dish	96
11341-8	Exh.	1.600	.3110	.600 Longer	5.540	.290	15° x 1/2"	.080	.100	9° Dish	99
11343-8	Exh.	1.600	.3110	.700 Longer	5.640	.290	15° x 1/2"	.080	.100	9° Dish	100
11303-8	Exh.	1.625	.3110	.100 Longer	5.040	.290	15° x 1/2"	.080	.100	9° Dish	97
11345-8	Exh.	1.625	.3110	.300 Longer	5.240	.290	15° x 1/2"	.080	.100	9° Dish	99
11347-8	Exh.	1.625	.3110	.600 Longer	5.540	.290	15° x 1/2"	.080	.100	9° Dish	102
11349-8	Exh.	1.625	.3110	.700 Longer	5.640	.290	15° x 1/2"	.080	.100	9° Dish	103
11302-8	Int.	1.940	.3110	.100 Longer	5.010	.290	10° x 3/8"	.050	.080	5° Dish	105
11304-8	Int.	2.020	.3110	.100 Longer	5.010	.290	10° x 3/8"	.050	.080	5° Dish	108
11306-8	Int.	2.055	.3110	.100 Longer	5.010	.290	10° x 3/8"	.050	.080	5° Dish	110
11704-8	Int.	2.055	.3110	.200 Longer	5.110	.290	10° x 3/8"	.050	.080	5° Dish	112
11706-8	Int.	2.080	.3110	.100 Longer	5.010	.290	10° x 3/8"	.050	.080	5° Dish	112
11708-8	Int.	2.080	.3110	.200 Longer	5.110	.290	10° x 3/8"	.050	.080	5° Dish	113
12314-8	Int.	2.100	.3110	.100 Longer	5.010	.290	10° x 3/8"	.050	.080	5° Dish	114
12316-8	Int.	2.100	.3110	.200 Longer	5.110	.290	10° x 3/8"	.050	.080	5° Dish	115
12318-8	Int.	2.125	.3110	.100 Longer	5.010	.290	10° x 3/8"	.050	.080	5° Dish	116
12320-8	Int.	2.125	.3110	.200 Longer	5.110	.290	10° x 3/8"	.050	.080	5° Dish	117
12322-8	Int.	2.180	.3110	.100 Longer	5.010	.290	10° x 3/8"	.050	.080	5° Dish	119
12324-8	Int.	2.180	.3110	.200 Longer	5.110	.290	10° x 3/8"	.050	.080	5° Dish	120
12326-8	Int.	2.200	.3110	.100 Longer	5.010	.290	10° x 3/8"	.050	.080	5° Dish	121
12328-8	Int.	2.200	.3110	.200 Longer	5.110	.290	10° x 3/8"	.050	.080	5° Dish	122

Small Block Chevrolet

Severe Duty® Valves

7mm (.274") Stem

- ▶ No Need for Inserted Tips or Wear Caps
- ▶ NK-844 Stainless Intake Material
- ▶ Swirl Polished and Fully Machined
- ▶ XH-428 Stainless Material
- ▶ Chrome Stems and Hard Tips
- ▶ Thin Stem for Increased Flow and Light Weight

These .274" stem valves are ONLY available with Bead Loc® keeper grooves. Bead Loc® valve locks are REQUIRED.

See page 61 for guides, seals and cutters required for installation of these valves.



Part No.	Type	Head Diameter	Stem Diameter	Installed Height	O / A Length	Tip Length	Underhead Angle / Radius	Margin	Seat Width	Top of Head	Wgt / Grams
11235-8	Exh.	1.600	.2740	.100 Longer	5.040	.290	15° x 1/2"	.080	.100	9° Dish	84
11236-8	Int.	1.940	.2740	.100 Longer	5.010	.290	10° x 3/8"	.050	.080	5° Dish	95
11238-8	Int.	2.020	.2740	.100 Longer	5.010	.290	10° x 3/8"	.050	.080	5° Dish	98
11240-8	Int.	2.055	.2740	.100 Longer	5.010	.290	10° x 3/8"	.050	.080	5° Dish	100

Small Block Chevrolet

Severe Duty® Valves

5/16" (.311") Stem

- ▶ No Need for Inserted Tips or Wear Caps
- ▶ NK-844 Stainless Intake Material
- ▶ Swirl Polished and Fully Machined
- ▶ XH-428 Stainless Material
- ▶ Chrome Stems and Hard Tips
- ▶ Thin Stem for Increased Flow and Light Weight

Hollow .311" stem Gen II blank P/N 11224H can be found on page 42 to support your custom requirements.

These .311" stem valves are ONLY available with Bead Loc® keeper grooves. Bead Loc® valve locks are REQUIRED.



Part No.	Type	Head Diameter	Stem Diameter	Installed Height	O / A Length	Tip Length	Underhead Angle / Radius	Margin	Seat Width	Top of Head	Wgt / Grams
11231-8	Exh.	1.600	.3110	.100 Longer	5.040	.290	15° x 1/2"	.080	.100	9° Dish	94
11351-8	Exh.	1.600	.3110	.200 Longer	5.140	.290	15° x 1/2"	.080	.100	9° Dish	95
11357-8	Exh.	1.600	.3110	.300 Longer	5.240	.290	15° x 1/2"	.080	.100	9° Dish	96
11359-8	Exh.	1.600	.3110	.600 Longer	5.540	.290	15° x 1/2"	.080	.100	9° Dish	99
11387-8	Exh.	1.600	.3110	.700 Longer	5.640	.290	15° x 1/2"	.080	.100	9° Dish	100
11389-8	Exh.	1.625	.3110	.300 Longer	5.240	.290	15° x 1/2"	.080	.100	9° Dish	99
11397-8	Exh.	1.625	.3110	.600 Longer	5.540	.290	15° x 1/2"	.080	.100	9° Dish	102
11399-8	Exh.	1.625	.3110	.700 Longer	5.640	.290	15° x 1/2"	.080	.100	9° Dish	103
11230-8	Int.	1.940	.3110	.100 Longer	5.010	.290	12° x 3/8"	.050	.080	7° Dish	105
11232-8	Int.	2.020	.3110	.100 Longer	5.010	.290	12° x 3/8"	.050	.080	7° Dish	108
11234-8	Int.	2.055	.3110	.100 Longer	5.010	.290	12° x 3/8"	.050	.080	7° Dish	110
11234H-8	Int.	2.055	.3110	.100 Longer	5.010	.290	12° x 3/8"	.050	.080	7° Dish	98
			Hollow Stem								
11710-8	Int.	2.055	.3110	.200 Longer	5.110	.290	12° x 3/8"	.050	.080	7° Dish	112
11710H-8	Int.	2.055	.3110	.200 Longer	5.110	.290	12° x 3/8"	.050	.080	7° Dish	100
			Hollow Stem								
11712-8	Int.	2.080	.3110	.100 Longer	5.010	.290	12° x 3/8"	.050	.080	7° Dish	112
11712H-8	Int.	2.080	.3110	.100 Longer	5.010	.290	12° x 3/8"	.050	.080	7° Dish	100
			Hollow Stem								
11714-8	Int.	2.080	.3110	.200 Longer	5.110	.290	12° x 3/8"	.050	.080	7° Dish	113
11714H-8	Int.	2.080	.3110	.200 Longer	5.110	.290	12° x 3/8"	.050	.080	7° Dish	101
			Hollow Stem								

Need a different length? Head diameter not listed? Prefer a BeadLoc® groove?
See pages 42 & 43 for Gen II blanks to construct a valve to your exact specifications.

STAINLESS VALVES

VALVES

Small Block Chevrolet Severe Duty® Exhaust Valves

- ▶ XH-428 Stainless Material
- ▶ Chrome Stems
- ▶ Hard Tips
- ▶ Swirl Polished
- ▶ Fully Machined



Part No.	Type	Head Diameter	Stem Diameter	Installed Height	O / A Length	Tip Length	Underhead Angle / Radius	Margin	Seat Width	Top of Head	Wgt / Grams
11567-8	Exh.	1.500	.3415	Stock	4.911	.250	10° x 3/8"	.060	.100	7° Dish	92
11887-8	Exh.	1.500	.3415	.100 Longer	5.036	.250	15° x 1/2"	.085	.085	10° Dish	94
11747-8	Exh.	1.500	.3415	.200 Longer	5.140	.290	15° x 1/2"	.085	.100	9° Dish	101
11543-8	Exh.	1.600	.3415	Stock	4.911	.250	10° x 3/8"	.060	.100	7° Dish	95
11595-8	Exh.	1.600	.3415	Stock	4.936	.250	10° x 3/8"	.085	.085	Flat Face	100
11539-8	Exh.	1.600	.3415	.100 Longer	5.036	.250	10° x 3/8"	.085	.085	7° Dish	102
11865-8	Exh.	1.600	.3415	.200 Longer	5.121	.250	15° x 1/2"	.070	.100	9° Dish	105
11551-8	Exh.	1.600	.3415	Stock	4.921	.250	30° x 1/2"	.070	.100	25° Dish	106
11869-8	Exh.	1.600	.3415	.100 Longer	5.021	.250	30° x 1/2"	.070	.100	25° Dish	109
11771-8	Exh.	1.600	.3415	.200 Longer	5.121	.250	30° x 1/2"	.070	.100	25° Dish	111
11785-8	Exh.	1.600	.3415	.300 Longer	5.221	.250	30° x 1/2"	.070	.100	25° Dish	113
11573-8	Exh.	1.600	.3415	Stock	4.965	.290	15° x 1/2"	.090	.100	9° Dish	107
11749-8	Exh.	1.600	.3415	.100 Longer	5.065	.290	15° x 1/2"	.090	.100	9° Dish	108
11751-8	Exh.	1.600	.3415	.200 Longer	5.165	.290	15° x 1/2"	.090	.100	9° Dish	110
11753-8	Exh.	1.600	.3415	.300 Longer	5.265	.290	15° x 1/2"	.090	.100	9° Dish	111
11755-8	Exh.	1.600	.3415	.400 Longer	5.365	.290	15° x 1/2"	.090	.100	9° Dish	112
11513-8	Exh.	1.600	.3415	.500 Longer	5.465	.290	15° x 1/2"	.090	.100	9° Dish	113
11767-8	Exh.	1.600	.3415	.600 Longer	5.565	.290	15° x 1/2"	.090	.100	9° Dish	114
11541-8	Exh.	1.625	.3415	Stock	4.911	.250	15° x 1/2"	.060	.100	9° Dish	95
11585-8	Exh.	1.625	.3415	Stock	4.936	.250	15° x 1/2"	.085	.100	9° Dish	106
11537-8	Exh.	1.625	.3415	.100 Longer	5.036	.250	15° x 1/2"	.085	.100	9° Dish	102
11871-8	Exh.	1.625	.3415	.200 Longer	5.121	.250	15° x 1/2"	.070	.100	9° Dish	105
11557-8	Exh.	1.625	.3415	Stock	4.921	.250	30° x 1/2"	.070	.100	25° Dish	109
11569-8	Exh.	1.625	.3415	.100 Longer	5.021	.250	30° x 1/2"	.070	.100	25° Dish	111
11571-8	Exh.	1.625	.3415	.200 Longer	5.121	.250	30° x 1/2"	.070	.100	25° Dish	113
11579-8	Exh.	1.625	.3415	.300 Longer	5.221	.250	30° x 1/2"	.070	.100	25° Dish	115
11851-8	Exh.	1.625	.3415	.100 Longer	5.065	.290	15° x 1/2"	.090	.100	9° Dish	109
11577-8	Exh.	1.625	.3415	.200 Longer	5.165	.290	15° x 1/2"	.090	.100	9° Dish	115
11757-8	Exh.	1.625	.3415	.300 Longer	5.265	.290	15° x 1/2"	.090	.100	9° Dish	116
11759-8	Exh.	1.625	.3415	.400 Longer	5.365	.290	15° x 1/2"	.090	.100	9° Dish	117
11511-8	Exh.	1.625	.3415	.500 Longer	5.465	.290	15° x 1/2"	.090	.100	9° Dish	118
11763-8	Exh.	1.625	.3415	.600 Longer	5.565	.290	15° x 1/2"	.090	.100	9° Dish	122

Need a different length? Head diameter not listed? Prefer a BeadLoc® groove?
See pages 42 & 43 for Gen II blanks to construct a valve to your exact specifications.

Small Block Chevrolet Severe Duty® Intake Valves

- ▶ NK-844 Stainless Material
- ▶ Hard Tips
- ▶ Fully Machined
- ▶ Chrome Stems
- ▶ Swirl Polished



Want a hollow stem Severe Duty® intake? It's as easy as 1-2-3. Refer to Gen II blank P/N 11254H on page 42 to support your custom requirements.

Part No.	Type	Head Diameter	Stem Diameter	Installed Height	O / A Length	Tip Length	Underhead Angle / Radius	Margin	Seat Width	Top of Head	Wgt / Grams
12342-8	Int.	1.720	.3415	Stock	4.911	.250	10° x 3/8"	.050	.080	5° Dish	97
11540-8	Int.	1.720	.3415	.100 Longer	5.011	.250	10° x 3/8"	.050	.080	5° Dish	99
11716-8	Int.	1.720	.3415	.200 Longer	5.140	.290	10° x 3/8"	.050	.100	5° Dish	103
11542-8	Int.	1.840	.3415	.100 Longer	5.011	.250	10° x 3/8"	.050	.080	5° Dish	106
11820-8	Int.	1.840	.3415	.200 Longer	5.140	.290	10° x 3/8"	.050	.100	5° Dish	110
11592-8	Int.	1.937	.3415	Stock	4.911	.250	10° x 3/8"	.050	.080	5° Dish	109
11886-8	Int.	1.940	.3415	.100 Longer	5.011	.250	10° x 3/8"	.050	.100	5° Dish	111
11748-8	Int.	1.940	.3415	.200 Longer	5.140	.290	10° x 3/8"	.050	.100	5° Dish	115
11596-8	Int.	2.020	.3415	Stock	4.911	.250	10° x 3/8"	.050	.080	7° Dish	111
11826-8	Int.	2.020	.3415	.100 Longer	5.026	.250	10° x 3/8"	.065	.080	5° Dish	113
11544-8	Int.	2.020	.3415	.200 Longer	5.140	.290	10° x 3/8"	.065	.080	5° Dish	125
11598-8	Int.	2.055	.3415	Stock	4.911	.250	12° x 3/8"	.050	.080	7° Dish	113
11828-8	Int.	2.055	.3415	Stock	4.926	.250	12° x 3/8"	.065	.080	Flat Face	128
11846-8	Int.	2.055	.3415	.100 Longer	5.026	.250	12° x 3/8"	.065	.080	7° Dish	125
11700-8	Int.	2.055	.3415	.200 Longer	5.140	.290	12° x 3/8"	.065	.080	7° Dish	127
11818-8	Int.	2.080	.3415	Stock	4.926	.250	12° x 3/8"	.065	.080	Flat Face	131
11844-8	Int.	2.080	.3415	.100 Longer	5.026	.250	12° x 3/8"	.065	.080	7° Dish	126
11858-8	Int.	2.080	.3415	.200 Longer	5.140	.290	12° x 3/8"	.065	.080	7° Dish	129
11762-8	Int.	2.080	.3415	.300 Longer	5.240	.290	12° x 3/8"	.065	.080	7° Dish	131
11764-8	Int.	2.080	.3415	.400 Longer	5.340	.290	12° x 3/8"	.065	.080	7° Dish	132
11512-8	Int.	2.080	.3415	.500 Longer	5.440	.290	12° x 3/8"	.065	.080	7° Dish	134
11852-8	Int.	2.100	.3415	.100 Longer	5.026	.250	12° x 3/8"	.065	.080	7° Dish	128
11862-8	Int.	2.100	.3415	.200 Longer	5.140	.290	12° x 3/8"	.065	.080	7° Dish	131
11750-8	Int.	2.100	.3415	.300 Longer	5.240	.290	12° x 3/8"	.065	.080	7° Dish	132
11752-8	Int.	2.100	.3415	.400 Longer	5.340	.290	12° x 3/8"	.065	.080	7° Dish	133
11510-8	Int.	2.100	.3415	.500 Longer	5.440	.290	12° x 3/8"	.065	.080	7° Dish	135
11770-8	Int.	2.100	.3415	.600 Longer	5.540	.290	12° x 3/8"	.065	.080	7° Dish	137
11848-8	Int.	2.125	.3415	.100 Longer	5.026	.250	12° x 3/8"	.065	.080	7° Dish	131
11866-8	Int.	2.125	.3415	.200 Longer	5.125	.250	12° x 3/8"	.065	.080	7° Dish	132
11754-8	Int.	2.125	.3415	.300 Longer	5.240	.290	12° x 3/8"	.065	.080	7° Dish	133
11756-8	Int.	2.125	.3415	.400 Longer	5.340	.290	12° x 3/8"	.065	.080	7° Dish	134
11508-8	Int.	2.125	.3415	.500 Longer	5.440	.290	12° x 3/8"	.065	.080	7° Dish	135
11768-8	Int.	2.125	.3415	.600 Longer	5.540	.290	12° x 3/8"	.065	.080	7° Dish	137
11758-8	Int.	2.150	.3415	.400 Longer	5.340	.290	12° x 3/8"	.065	.080	7° Dish	133
11760-8	Int.	2.150	.3415	.500 Longer	5.440	.290	12° x 3/8"	.065	.080	7° Dish	135
11766-8	Int.	2.150	.3415	.600 Longer	5.540	.290	12° x 3/8"	.065	.080	7° Dish	137

Need a different length? Head diameter not listed? Prefer a BeadLoc® groove?
See pages 42 & 43 for Gen II blanks to construct a valve to your exact specifications.

Small Block Chevrolet

Severe Duty® "Pro Flo" Valves

- ▶ XH-428 Stainless Exhaust Material
- ▶ NK-844 Stainless Intake Material
- ▶ Chrome Stems and Hard Tips
- ▶ Swirl Polished and Fully Machined
- ▶ Improved Flow with "Pro Flo" Underhead



Part No.	Type	Head Diameter	Stem Diameter	Installed Height	O / A Length	Tip Length	Underhead Angle / Radius	Margin	Seat Width	Top of Head	Wgt / Grams
11827-8	Exh.	1.600	.3415	Stock	4.936	.250	Pro Flo: 12° x 3/8"	.085	.080	7° Dish	98
11823-8	Exh.	1.600	.3415	.100 Longer	5.036	.250	Pro Flo: 12° x 3/8"	.085	.080	7° Dish	100
11840-8	Int.	1.937	.3415	Stock	4.911	.250	Pro Flo: 12° x 3/8"	.050	.080	7° Dish	111
11830-8	Int.	2.020	.3415	Stock	4.911	.250	Pro Flo: 12° x 3/8"	.050	.080	7° Dish	114
11882-8	Int.	2.020	.3415	.100 Longer	5.011	.250	Pro Flo: 12° x 3/8"	.050	.080	7° Dish	115
11732-8	Int.	2.055	.3415	Stock	4.911	.250	Pro Flo: 12° x 3/8"	.050	.080	7° Dish	115
11824-8	Int.	2.055	.3415	.100 Longer	5.011	.250	Pro Flo: 12° x 3/8"	.050	.080	7° Dish	116
11734-8	Int.	2.055	.3415	.200 Longer	5.111	.250	Pro Flo: 12° x 3/8"	.050	.080	7° Dish	117
11736-8	Int.	2.080	.3415	Stock	4.911	.250	Pro Flo: 12° x 3/8"	.050	.080	7° Dish	117
11772-8	Int.	2.080	.3415	.100 Longer	5.011	.250	Pro Flo: 12° x 3/8"	.050	.080	7° Dish	118
11738-8	Int.	2.080	.3415	.200 Longer	5.111	.250	Pro Flo: 12° x 3/8"	.050	.080	7° Dish	119
11740-8	Int.	2.080	.3415	.300 Longer	5.211	.250	Pro Flo: 12° x 3/8"	.050	.080	7° Dish	120
11742-8	Int.	2.100	.3415	.100 Longer	5.011	.250	Pro Flo: 12° x 3/8"	.050	.080	7° Dish	119
11744-8	Int.	2.100	.3415	.200 Longer	5.111	.250	Pro Flo: 12° x 3/8"	.050	.080	7° Dish	120
11746-8	Int.	2.100	.3415	.300 Longer	5.211	.250	Pro Flo: 12° x 3/8"	.050	.080	7° Dish	121

Small Block Chevrolet

Extreme Duty Exhaust Valves

- ▶ XH-432 XtremeAlloy Material
- ▶ Chrome Stems and Hard Tips
- ▶ Swirl Polished and Fully Machined



Part No.	Type	Head Diameter	Stem Diameter	Installed Height	O / A Length	Tip Length	Underhead Angle / Radius	Margin	Seat Width	Top of Head	Wgt / Grams
11599-8	Exh.	1.600	.3415	.050 Longer	5.015	.290	15° x 1/2"	.080	.100	9° Dish	106
11701-8	Exh.	1.600	.3415	.100 Longer	5.065	.290	15° x 1/2"	.080	.100	9° Dish	108
11705-8	Exh.	1.600	.3415	.200 Longer	5.165	.290	15° x 1/2"	.080	.100	9° Dish	110
11709-8	Exh.	1.600	.3415	.300 Longer	5.265	.290	15° x 1/2"	.080	.100	9° Dish	111
11711-8	Exh.	1.600	.3415	.400 Longer	5.365	.290	15° x 1/2"	.080	.100	9° Dish	112
11713-8	Exh.	1.625	.3415	.100 Longer	5.065	.290	15° x 1/2"	.080	.100	9° Dish	110
11715-8	Exh.	1.625	.3415	.200 Longer	5.165	.290	15° x 1/2"	.080	.100	9° Dish	111
11721-8	Exh.	1.625	.3415	.300 Longer	5.265	.290	15° x 1/2"	.080	.100	9° Dish	112
11725-8	Exh.	1.625	.3415	.400 Longer	5.365	.290	15° x 1/2"	.080	.100	9° Dish	113

Small Block Chevrolet

Severe Duty® Valves NHRA Legal Super Stock



- ▶ XH-428 Stainless Exhaust Material
- ▶ NK-844 Stainless Intake Material
- ▶ Chrome Stems and Hard Tips
- ▶ Swirl Polished and Fully Machined

Part No.	Type	Head Diameter	Stem Diameter	Installed Height	O / A Length	Tip Length	Underhead Angle / Radius	Margin	Seat Width	Top of Head	Wgt / Grams
11567-8	Exh.	1.500	.3415	Stock	4.911	.250	10° x 3/8"	.060	.100	7° Dish	92
11887-8	Exh.	1.500	.3415	.100 Longer	5.036	.250	15° x 1/2"	.085	.100	10° Dish	94
11747-8	Exh.	1.500	.3415	.200 Longer	5.140	.290	15° x 1/2"	.085	.100	9° Dish	101
11540-8	Int.	1.720	.3415	.100 Longer	5.011	.250	10° x 3/8"	.050	.080	5° Dish	99
11542-8	Int.	1.840	.3415	.100 Longer	5.011	.250	10° x 3/8"	.050	.080	5° Dish	106
11886-8	Int.	1.940	.3415	.100 Longer	5.011	.250	10° x 3/8"	.050	.100	5° Dish	111
11748-8	Int.	1.940	.3415	.200 Longer	5.140	.290	10° x 3/8"	.050	.100	5° Dish	115

409 Chevrolet

Race Master Valves

- ▶ XH-426 Stainless Exhaust Material
- ▶ NK-842 Stainless Intake Material
- ▶ Chrome Stems and Hard Tips
- ▶ Swirl Polished and Fully Machined
- ▶ Straight Stems



Part No.	Type	Head Diameter	Stem Diameter	Installed Height	O/A Length	Tip Length	Underhead Angle/Radius	Margin	Seat Width	Top of Head	Wgt/ Grams
11311-8	Exh.	1.735	.3715	Stock	5.105	.225	15° x 1/2"	.080	.100	9° Dish	115
11313-8	Exh.	1.750	.3715	Stock	5.105	.225	15° x 1/2"	.080	.100	9° Dish	117
11310-8	Int.	2.200	.3715	Stock	5.105	.225	12° x 3/8"	.065	.080	7° Dish	139
11312-8	Int.	2.250	.3715	Stock	5.105	.225	12° x 3/8"	.065	.080	7° Dish	141

STAINLESS VALVES

VALVES

Big Block Chevrolet

Street Flo Valves

Stock 3/8" Stem Diameters

- ▶ XH-424 Stainless Exhaust Material
- ▶ Chrome Stems and Hard Tips
- ▶ Improved Flow with "Pro Flo" Underhead
- ▶ NK-841 Stainless Intake Material
- ▶ Swirl Polished and Fully Machined



Part No.	Type	Head Diameter	Stem Diameter	Installed Height	O/A Length	Tip Length	Underhead Angle/Radius	Margin	Seat Width	Top of Head	Wgt/ Grams
10717-8	Exh.	1.725	.3715	Stock	5.350	.220	Pro Flo: 10° x 3/8"	.060	.100	5° Dish	120
10727-8	Exh.	1.880	.3715	Stock	5.350	.220	Pro Flo: 10° x 3/8"	.060	.100	5° Dish	131
10714-8	Int.	2.065	.3715	Stock	5.218	.220	Pro Flo: 10° x 3/8"	.050	.080	5° Dish	130
10728-8	Int.	2.190	.3715	Stock	5.218	.220	Pro Flo: 10° x 3/8"	.050	.080	5° Dish	135
10726-8	Int.	2.250	.3715	Stock	5.218	.220	Pro Flo: 10° x 3/8"	.050	.080	5° Dish	138

Big Block Chevrolet

Race Flo Valves

Stock 3/8" Stem Diameters

- ▶ XH-426 Stainless Exhaust Material
- ▶ Chrome Stems and Hard Tips
- ▶ Improved Flow with "Pro Flo" Underhead
- ▶ NK-842 Stainless Intake Material
- ▶ Swirl Polished and Fully Machined



Part No.	Type	Head Diameter	Stem Diameter	Installed Height	O/A Length	Tip Length	Underhead Angle/Radius	Margin	Seat Width	Top of Head	Wgt/ Grams
11517-8	Exh.	1.725	.3715	Stock	5.350	.220	Pro Flo: 10° x 3/8"	.060	.100	5° Dish	120
11527-8	Exh.	1.880	.3715	Stock	5.350	.220	Pro Flo: 10° x 3/8"	.060	.100	5° Dish	131
11514-8	Int.	2.065	.3715	Stock	5.218	.220	Pro Flo: 10° x 3/8"	.050	.080	5° Dish	130
11528-8	Int.	2.190	.3715	Stock	5.218	.220	Pro Flo: 10° x 3/8"	.050	.080	5° Dish	135
11526-8	Int.	2.250	.3715	Stock	5.218	.220	Pro Flo: 10° x 3/8"	.050	.080	5° Dish	138

Big Block Chevrolet

Race Master Valves

Stock 3/8" Stem Diameters

- ▶ XH-426 Stainless Exhaust Material
- ▶ Chrome Stems and Hard Tips
- ▶ Improved Flow with "Pro Flo" Underhead
- ▶ NK-842 Stainless Intake Material
- ▶ Swirl Polished and Fully Machined



Part No.	Type	Head Diameter	Stem Diameter	Installed Height	O/A Length	Tip Length	Underhead Angle/Radius	Margin	Seat Width	Top of Head	Wgt/ Grams
11509-8	Exh.	1.880	.3715	Stock	5.422	.250	15° x 1/2"	.075	.100	9° Dish	139
11515-8	Exh.	1.880	.3715	.100 Longer	5.522	.250	15° x 1/2"	.075	.100	9° Dish	141
11707-8	Exh.	1.900	.3715	Stock	5.422	.250	15° x 1/2"	.075	.100	9° Dish	141
11723-8	Exh.	1.900	.3715	.100 Longer	5.522	.250	15° x 1/2"	.075	.100	9° Dish	143
11849-8	Exh.	1.940	.3715	Stock	5.422	.250	15° x 1/2"	.075	.100	9° Dish	144
11893-8	Exh.	1.940	.3715	.100 Longer	5.522	.250	15° x 1/2"	.075	.100	9° Dish	146
11718-8	Int.	2.190	.3715	Stock	5.244	.250	12° x 3/8"	.050	.080	7° Dish	150
11720-8	Int.	2.190	.3715	.100 Longer	5.344	.250	12° x 3/8"	.050	.080	7° Dish	152
11722-8	Int.	2.250	.3715	Stock	5.244	.250	12° x 3/8"	.050	.080	7° Dish	153
11724-8	Int.	2.250	.3715	.100 Longer	5.344	.250	12° x 3/8"	.050	.080	7° Dish	155
11726-8	Int.	2.300	.3715	Stock	5.244	.250	12° x 3/8"	.050	.080	7° Dish	156
11728-8	Int.	2.300	.3715	.100 Longer	5.344	.250	12° x 3/8"	.050	.080	7° Dish	158

Big Block Chevrolet

Severe Duty® Valves Stock 3/8" Stem Diameters

- ▶ XH-428 Stainless Exhaust Material
- ▶ NK-844 Stainless Intake Material
- ▶ Chrome Stems and Hard Tips
- ▶ Swirl Polished and Fully Machined

Want a hollow stem Severe Duty® intake? It's as easy as 1-2-3. Refer to Gen II blank P/N 11252H on page 42 to support your custom requirements.



Part No.	Type	Head Diameter	Stem Diameter	Installed Height	O/A Length	Tip Length	Underhead Angle/Radius	Margin	Seat Width	Top of Head	Wgt/ Grams
11553-8	Exh.	1.720	.3715	Stock	5.354	.220	10° x 3/8"	.065	.100	6° Dish	122
11519-8	Exh.	1.725	.3715	.100 Longer	5.464	.220	12° x 3/8"	.075	.100	7° Dish	125
11563-8	Exh.	1.880	.3715	Stock	5.354	.220	10° x 3/8"	.065	.100	6° Dish	134
11525-8	Exh.	1.880	.3715	.100 Longer	5.464	.220	12° x 3/8"	.075	.100	7° Dish	138
11593-8	Exh.	1.900	.3715	Stock	5.364	.220	12° x 3/8"	.075	.100	7° Dish	140
11535-8	Exh.	1.900	.3715	.100 Longer	5.464	.220	12° x 3/8"	.075	.100	7° Dish	142
11561-8	Exh.	1.940	.3715	Stock	5.364	.220	12° x 3/8"	.075	.100	7° Dish	143
11533-8	Exh.	1.940	.3715	.100 Longer	5.464	.220	12° x 3/8"	.075	.100	7° Dish	145
11836-8	Int.	2.065	.3720	Stock	5.218	.220	Pro Flo: 10° x 3/8"	.050	.080	5° Dish	131
11554-8	Int.	2.065	.3720	.100 Longer	5.325	.220	Pro Flo: 12° x 7/16"	.065	.080	7° Dish	138
11520-8	Int.	2.190	.3720	Stock	5.218	.220	10° x 3/8"	.050	.080	7° Dish	145
11832-8	Int.	2.190	.3720	Stock	5.218	.220	Pro Flo: 10° x 3/8"	.050	.080	5° Dish	138
11538-8	Int.	2.190	.3720	.100 Longer	5.325	.220	Pro Flo: 12° x 7/16"	.065	.080	7° Dish	146
11562-8	Int.	2.250	.3720	Stock	5.218	.220	10° x 3/8"	.050	.080	7° Dish	149
11524-8	Int.	2.250	.3720	.100 Longer	5.325	.220	Pro Flo: 12° x 7/16"	.065	.080	7° Dish	153
11534-8	Int.	2.250	.3720	.200 Longer	5.433	.220	Pro Flo: 12° x 7/16"	.065	.080	7° Dish	156
11530-8	Int.	2.300	.3720	.100 Longer	5.325	.220	Pro Flo: 12° x 7/16"	.065	.080	7° Dish	160
11536-8	Int.	2.300	.3720	.200 Longer	5.433	.220	Pro Flo: 12° x 7/16"	.065	.080	7° Dish	168
11570-8	Int.	2.300	.3720	.250 Longer	5.513	.250	Pro Flo: 12° x 7/16"	.065	.080	7° Dish	171

Big Block Chevrolet

Severe Duty® "Pro Flo" Valves Stock 3/8" Stem Diameters

- ▶ XH-428 Stainless Exhaust Material
- ▶ NK-844 Stainless Intake Material
- ▶ Improved Flow with "Pro Flo" Underhead
- ▶ Chrome Stems and Hard Tips
- ▶ Swirl Polished and Fully Machined

Want a hollow stem Severe Duty® intake? It's as easy as 1-2-3. Refer to Gen II blank P/N 11252H on page 42 to support your custom requirements.



Part No.	Type	Head Diameter	Stem Diameter	Installed Height	O/A Length	Tip Length	Underhead Angle/Radius	Margin	Seat Width	Top of Head	Wgt/ Grams
11835-8	Exh.	1.725	.3715	Stock	5.374	.220	Pro Flo: 10° x 3/8"	.085	.100	5° Dish	121
11831-8	Exh.	1.880	.3715	Stock	5.374	.220	Pro Flo: 10° x 3/8"	.085	.100	5° Dish	132
11836-8	Int.	2.065	.3720	Stock	5.218	.220	Pro Flo: 10° x 3/8"	.050	.080	5° Dish	131
11554-8	Int.	2.065	.3720	.100 Longer	5.325	.220	Pro Flo: 12° x 7/16"	.065	.080	7° Dish	138
11832-8	Int.	2.190	.3720	Stock	5.218	.220	Pro Flo: 10° x 3/8"	.050	.080	5° Dish	138
11538-8	Int.	2.190	.3720	.100 Longer	5.325	.220	Pro Flo: 12° x 7/16"	.065	.080	7° Dish	146
11524-8	Int.	2.250	.3720	.100 Longer	5.325	.220	Pro Flo: 12° x 7/16"	.065	.080	7° Dish	153
11534-8	Int.	2.250	.3720	.200 Longer	5.433	.220	Pro Flo: 12° x 7/16"	.065	.080	7° Dish	156
11530-8	Int.	2.300	.3720	.100 Longer	5.325	.220	Pro Flo: 12° x 7/16"	.065	.080	7° Dish	160
11536-8	Int.	2.300	.3720	.200 Longer	5.433	.220	Pro Flo: 12° x 7/16"	.065	.080	7° Dish	168
11570-8	Int.	2.300	.3720	.250 Longer	5.513	.250	Pro Flo: 12° x 7/16"	.065	.080	7° Dish	171

Big Block Chevrolet

Extreme Duty & Marine Valves

Stock 3/8" Stem Diameters

- ▶ XH-432 XtremeAlloy Exhaust Material
- ▶ Swirl Polished and Fully Machined
- ▶ NK-844 Intake Material
- ▶ Chrome Stems and Hard Tips



Want a hollow stem Severe Duty® intake? It's as easy as 1-2-3. Refer to Gen II blank P/N 11252H on page 42 to support your custom requirements.

Part No.	Type	Head Diameter	Stem Diameter	Installed Height	O/A Length	Tip Length	Underhead Angle/Radius	Margin	Seat Width	Top of Head	Wgt/ Grams
11587-8	Exh.	1.880	.3715	Stock	5.354	.220	10° x 3/8"	.065	.100	6° Dish	139
11731-8	Exh.	1.880	.3715	.100 Longer	5.454	.220	10° x 3/8"	.065	.100	6° Dish	142
11507-8	Exh.	1.900	.3715	Stock	5.354	.220	10° x 3/8"	.065	.100	6° Dish	140
11733-8	Exh.	1.900	.3715	.100 Longer	5.454	.220	10° x 3/8"	.075	.100	6° Dish	143
11735-8	Exh.	1.940	.3715	.100 Longer	5.454	.220	10° x 3/8"	.065	.100	6° Dish	144
11836-8	Int.	2.065	.3720	Stock	5.218	.220	Pro Flo: 10° x 3/8"	.050	.080	5° Dish	131
11554-8	Int.	2.065	.3720	.100 Longer	5.325	.220	Pro Flo: 12° x 7/16"	.065	.080	7° Dish	138
11520-8	Int.	2.190	.3720	Stock	5.218	.220	10° x 3/8"	.050	.080	7° Dish	145
11832-8	Int.	2.190	.3720	Stock	5.218	.220	Pro Flo: 10° x 3/8"	.050	.080	5° Dish	138
11538-8	Int.	2.190	.3720	.100 Longer	5.325	.220	Pro Flo: 12° x 7/16"	.065	.080	7° Dish	146
11562-8	Int.	2.250	.3720	Stock	5.218	.220	10° x 3/8"	.050	.080	7° Dish	149
11524-8	Int.	2.250	.3720	.100 Longer	5.325	.220	Pro Flo: 12° x 7/16"	.065	.080	7° Dish	153
11534-8	Int.	2.250	.3720	.200 Longer	5.433	.220	Pro Flo: 12° x 7/16"	.065	.080	7° Dish	156
11530-8	Int.	2.300	.3720	.100 Longer	5.325	.220	Pro Flo: 12° x 7/16"	.065	.080	7° Dish	160
11536-8	Int.	2.300	.3720	.200 Longer	5.433	.220	Pro Flo: 12° x 7/16"	.065	.080	7° Dish	168
11570-8	Int.	2.300	.3720	.250 Longer	5.513	.250	Pro Flo: 12° x 7/16"	.065	.080	7° Dish	171

Big Block Chevrolet

Street Master Valves

1 1/32" Stem Diameters

- ▶ XH-424 Stainless Exhaust Material
- ▶ Swirl Polished and Fully Machined
- ▶ 1 1/32" Stems for Improved Flow, Lighter Weight
- ▶ NK-841 Intake Material
- ▶ Chrome Stems and Hard Tips



Part No.	Type	Head Diameter	Stem Diameter	Installed Height	O/A Length	Tip Length	Underhead Angle/Radius	Margin	Seat Width	Top of Head	Wgt/ Grams
10881-8	Exh.	1.880	.3415	Stock	5.422	.250	10° x 3/8"	.075	.100	6° Dish	122
10761-8	Exh.	1.880	.3415	.100 Longer	5.522	.250	10° x 3/8"	.075	.100	6° Dish	124
10883-8	Exh.	1.900	.3415	Stock	5.422	.250	10° x 3/8"	.075	.100	5° Dish	124
10769-8	Exh.	1.900	.3415	.100 Longer	5.522	.250	10° x 3/8"	.075	.100	5° Dish	125
10872-8	Int.	2.190	.3415	Stock	5.244	.250	10° x 3/8"	.050	.080	5° Dish	129
10894-8	Int.	2.190	.3415	.100 Longer	5.344	.250	10° x 3/8"	.050	.080	5° Dish	130
10874-8	Int.	2.250	.3415	Stock	5.244	.250	10° x 3/8"	.050	.080	5° Dish	130
10814-8	Int.	2.250	.3415	.100 Longer	5.344	.250	10° x 3/8"	.050	.080	5° Dish	132
10868-8	Int.	2.250	.3415	.250 Longer	5.494	.250	10° x 3/8"	.050	.080	5° Dish	135

Big Block Chevrolet

Race Master Valves 11/32" Stem Diameters

- ▶ XH-426 Stainless Exhaust Material
- ▶ Chrome Stems and Hard Tips
- ▶ 11/32" Stems for Improved Flow, Lighter Weight
- ▶ NK-842 Stainless Intake Material
- ▶ Swirl Polished and Fully Machined

Part No.	Type	Head Diameter	Stem Diameter	Installed Height	O/A Length	Tip Length	Underhead Angle/Radius	Margin	Seat Width	Top of Head	Wgt/ Grams
11881-8	Exh.	1.880	.3415	Stock	5.422	.250	10° x 3/8"	.075	.100	6° Dish	122
11717-8	Exh.	1.880	.3415	Stock	5.422	.250	25° x 3/8"	.075	.100	20° Dish	127
11761-8	Exh.	1.880	.3415	.100 Longer	5.522	.250	10° x 3/8"	.075	.100	6° Dish	124
11719-8	Exh.	1.880	.3415	.100 Longer	5.522	.250	25° x 3/8"	.075	.100	20° Dish	129
11883-8	Exh.	1.900	.3415	Stock	5.422	.250	10° x 3/8"	.075	.100	5° Dish	124
11765-8	Exh.	1.900	.3415	Stock	5.422	.250	25° x 3/8"	.075	.100	20° Dish	128
11769-8	Exh.	1.900	.3415	.100 Longer	5.522	.250	10° x 3/8"	.075	.100	5° Dish	125
11775-8	Exh.	1.900	.3415	.100 Longer	5.522	.250	25° x 3/8"	.075	.100	20° Dish	130
11885-8	Exh.	1.940	.3415	Stock	5.422	.250	10° x 3/8"	.075	.100	5° Dish	124
11777-8	Exh.	1.940	.3415	.100 Longer	5.522	.250	10° x 3/8"	.075	.100	5° Dish	126
11872-8	Int.	2.190	.3415	Stock	5.244	.250	10° x 3/8"	.050	.080	5° Dish	129
11894-8	Int.	2.190	.3415	.100 Longer	5.344	.250	10° x 3/8"	.050	.080	5° Dish	130
11874-8	Int.	2.250	.3415	Stock	5.244	.250	10° x 3/8"	.050	.080	5° Dish	130
11814-8	Int.	2.250	.3415	.100 Longer	5.344	.250	10° x 3/8"	.050	.080	5° Dish	132
11868-8	Int.	2.250	.3415	.250 Longer	5.494	.250	10° x 3/8"	.050	.080	5° Dish	135
11730-8	Int.	2.300	.3415	Stock	5.244	.250	10° x 3/8"	.050	.080	5° Dish	133
11816-8	Int.	2.300	.3415	.100 Longer	5.344	.250	10° x 3/8"	.050	.080	5° Dish	136
11870-8	Int.	2.300	.3415	.250 Longer	5.494	.250	10° x 3/8"	.050	.080	5° Dish	137

Big Block Chevrolet

Severe Duty® Valves 11/32" Stem Diameters

- ▶ XH-428 Stainless Exhaust Material
- ▶ Chrome Stems and Hard Tips
- ▶ NK-844 Stainless Intake Material
- ▶ Swirl Polished and Fully Machined

Part No.	Type	Head Diameter	Stem Diameter	Installed Height	O/A Length	Tip Length	Underhead Angle/Radius	Margin	Seat Width	Top of Head	Wgt/ Grams
11843-8	Exh.	1.880	.3415	Stock	5.422	.250	10° x 3/8"	.075	.085	6° Dish	122
11815-8	Exh.	1.880	.3415	.100 Longer	5.522	.250	10° x 3/8"	.075	.085	6° Dish	125
11845-8	Exh.	1.880	.3415	.100 Longer	5.522	.250	25° x 3/8"	.075	.100	20° Dish	130
11817-8	Exh.	1.900	.3415	Stock	5.422	.250	12° x 3/8"	.075	.085	7° Dish	122
11811-8*	Exh.	1.900	.3415	.100 Longer	5.522	.250	12° x 3/8"	.075	.085	7° Dish	126
11847-8	Exh.	1.900	.3415	.100 Longer	5.522	.250	25° x 3/8"	.075	.100	20° Dish	132
11803-8	Exh.	1.940	.3415	Stock	5.422	.250	12° x 3/8"	.075	.085	7° Dish	123
11809-8	Exh.	1.940	.3415	.100 Longer	5.522	.250	12° x 3/8"	.075	.085	7° Dish	127
11800-8	Int.	2.190	.3415	Stock	5.244	.250	12° x 3/8"	.050	.080	7° Dish	139
11822-8	Int.	2.190	.3415	.100 Longer	5.344	.250	12° x 3/8"	.050	.080	7° Dish	140
11896-8	Int.	2.190	.3415	.350 Longer	5.610	.250	12° x 3/8"	.065	.100	7° Dish	146
11802-8	Int.	2.250	.3415	Stock	5.244	.250	12° x 3/8"	.050	.100	7° Dish	139
11850-8	Int.	2.250	.3415	.100 Longer	5.344	.250	12° x 3/8"	.050	.100	7° Dish	142
11856-8	Int.	2.250	.3415	.250 Longer	5.494	.250	12° x 3/8"	.050	.100	7° Dish	145
11898-8	Int.	2.250	.3415	.350 Longer	5.610	.250	12° x 3/8"	.065	.100	7° Dish	150
11780-8	Int.	2.300	.3415	Stock	5.244	.250	12° x 3/8"	.050	.100	7° Dish	143
11842-8	Int.	2.300	.3415	.100 Longer	5.344	.250	12° x 3/8"	.050	.100	7° Dish	146
11784-8	Int.	2.300	.3415	.200 Longer	5.444	.250	12° x 3/8"	.050	.100	7° Dish	147
11854-8	Int.	2.300	.3415	.250 Longer	5.494	.250	12° x 3/8"	.050	.100	7° Dish	148
11878-8	Int.	2.300	.3415	.350 Longer	5.610	.250	12° x 3/8"	.065	.100	7° Dish	149
11838-8	Int.	2.325	.3415	.250 Longer	5.509	.250	12° x 3/8"	.065	.100	7° Dish	150
11880-8	Int.	2.350	.3415	.350 Longer	5.610	.250	12° x 3/8"	.065	.100	7° Dish	152

* Also available with Bead Loc® keeper grooves. Please order P/N 11811B-8

STAINLESS VALVES

VALVES

Big Block Chevrolet

Extreme Duty & Marine Valves 11/32" Stem Diameters

- ▶ XH-432 XtremeAlloy Exhaust Material
- ▶ NK-844 Stainless Intake Material
- ▶ Greater Flow and Less Weight
- ▶ Reduced Stem Diameter
- ▶ Chrome Stems and Hard Tips
- ▶ Swirl Polished and Fully Machined

Part No.	Type	Head Diameter	Stem Diameter	Installed Height	O/A Length	Tip Length	Underhead Angle/Radius	Margin	Seat Width	Top of Head	Wgt/ Grams
EXTREME DUTY VALVES											
11743-8	Exh.	1.880	.3415	Stock	5.422	.250	15° x 1/2"	.075	.085	9° Dish	133
12743-8	Exh.	1.880	.3415	Stock	5.422	.250	18° x 1/2"	.075	.085	12° Dish	133
11737-8	Exh.	1.880	.3415	.100 Longer	5.522	.250	15° x 1/2"	.075	.085	9° Dish	133
12737-8	Exh.	1.880	.3415	.100 Longer	5.522	.250	18° x 1/2"	.075	.085	12° Dish	133
11745-8	Exh.	1.900	.3415	Stock	5.422	.250	15° x 1/2"	.075	.085	9° Dish	136
12745-8	Exh.	1.900	.3415	Stock	5.422	.250	18° x 1/2"	.075	.085	12° Dish	136
11739-8	Exh.	1.900	.3415	.100 Longer	5.522	.250	15° x 1/2"	.075	.085	9° Dish	136
12739-8	Exh.	1.900	.3415	.100 Longer	5.522	.250	18° x 1/2"	.075	.085	12° Dish	136
11773-8	Exh.	1.940	.3415	Stock	5.422	.250	15° x 1/2"	.075	.085	9° Dish	140
12773-8	Exh.	1.940	.3415	Stock	5.422	.250	18° x 1/2"	.075	.085	12° Dish	140
11741-8	Exh.	1.940	.3415	.100 Longer	5.522	.250	15° x 1/2"	.075	.085	9° Dish	140
12741-8	Exh.	1.940	.3415	.100 Longer	5.522	.250	18° x 1/2"	.075	.085	12° Dish	140

Gen II blank P/N 11277 is also available with an 18° back angle, flat face (no dish). Refer to page 42.

SEVERE DUTY VALVES											
11800-8	Int.	2.190	.3415	Stock	5.244	.250	12° x 3/8"	.050	.080	7° Dish	139
11822-8	Int.	2.190	.3415	.100 Longer	5.344	.250	12° x 3/8"	.050	.080	7° Dish	140
11896-8	Int.	2.190	.3415	.350 Longer	5.610	.250	12° x 3/8"	.065	.100	7° Dish	146
11802-8	Int.	2.250	.3415	Stock	5.244	.250	12° x 3/8"	.050	.100	7° Dish	139
11850-8	Int.	2.250	.3415	.100 Longer	5.344	.250	12° x 3/8"	.050	.100	7° Dish	142
11856-8	Int.	2.250	.3415	.250 Longer	5.494	.250	12° x 3/8"	.050	.100	7° Dish	145
11898-8	Int.	2.250	.3415	.350 Longer	5.610	.250	12° x 3/8"	.065	.100	7° Dish	150
11780-8	Int.	2.300	.3415	Stock	5.244	.250	12° x 3/8"	.050	.100	7° Dish	143
11842-8	Int.	2.300	.3415	.100 Longer	5.344	.250	12° x 3/8"	.050	.100	7° Dish	146
11784-8	Int.	2.300	.3415	.200 Longer	5.444	.250	12° x 3/8"	.050	.100	7° Dish	147
11854-8	Int.	2.300	.3415	.250 Longer	5.494	.250	12° x 3/8"	.050	.100	7° Dish	148
11878-8	Int.	2.300	.3415	.350 Longer	5.610	.250	12° x 3/8"	.065	.100	7° Dish	149
11838-8	Int.	2.325	.3415	.250 Longer	5.509	.250	12° x 3/8"	.065	.100	7° Dish	150
11880-8	Int.	2.350	.3415	.350 Longer	5.610	.250	12° x 3/8"	.065	.100	7° Dish	152

Brodix 383 Head Hunter™, BB-4/SAR, SR20, Edelbrock Victor #12363425 Heads 11/32" Stem Diameters

Part No.	Type	Head Diameter	Stem Diameter	Installed Height	O/A Length	Tip Length	Underhead Angle/Radius	Margin	Seat Width/Angle	Top of Head	Wgt/ Grams
RACE MASTER VALVES											
12341-8**	Exh.	1.800	.3415	.500 Longer	5.930	.250	25° x 3/8"	.080	.060/55°	20° Dish	135
SEVERE DUTY VALVES											
12343-8**	Exh.	1.800	.3415	.500 Longer	5.930	.250	25° x 3/8"	.080	.060/55°	20° Dish	135
12339-8*	Exh.	1.850	.3415	.100 Longer	5.500	.250	12° x 3/8"	.075	.075/55°	7° Dish	125
11845-8	Exh.	1.880	.3415	.100 Longer	5.522	.250	25° x 3/8"	.075	.100/45°	20° Dish	130
11847-8	Exh.	1.900	.3415	.100 Longer	5.522	.250	25° x 3/8"	.075	.100/45°	20° Dish	132
11896-8	Int.	2.190	.3415	.350 Longer	5.610	.250	12° x 3/8"	.065	.100/45°	7° Dish	146
11898-8	Int.	2.250	.3415	.350 Longer	5.610	.250	12° x 3/8"	.065	.100/45°	7° Dish	148
11878-8	Int.	2.300	.3415	.350 Longer	5.610	.250	12° x 3/8"	.065	.100/45°	7° Dish	148
11880-8	Int.	2.350	.3415	.350 Longer	5.610	.250	12° x 3/8"	.065	.100/45°	7° Dish	150
12340-8*	Int.	2.375	.3415	.350 Longer	5.600	.250	12° x 3/8"	.060	.080/52°	7° Dish	152
12344-8**	Int.	2.400	.3415	.780 Longer	6.030	.250	10° x 3/8"	.055	.060/50°	5° Dish	164
EXTREME DUTY VALVES											
12351-8**	Exh.	1.800	.3415	.500 Longer	5.930	.250	15° x 1/2"	.080	.060/55°	9° Dish	142

* These valves are specifically produced for the Brodix 383 Head Hunter™ cylinder heads. Brodix equivalents: Manley P/N 12339 = BR81185, Manley P/N 12340 = BR81375

** These valves are specifically produced for the Brodix SR20 cylinder heads. The exhaust valves include a .050" x .45° back cut and the intake includes a .035" x 33° back cut. Brodix equivalents: Manley P/N's 12341 and 12343 = BR81080, Manley P/N 12344 = BR81403

Dart Big Block Pro 1® & 320 / 360 Heads Severe Duty® Valves 11/32" Stem Diameters

Part No.	Type	Head Diameter	Stem Diameter	Installed Height	O/A Length	Tip Length	Underhead Angle/Radius	Margin	Seat Width	Top of Head	Wgt/ Grams
11843-8	Exh.	1.880	.3415	Stock	5.422	.250	10° x 3/8"	.075	.085	6° Dish	122
11817-8	Exh.	1.900	.3415	Stock	5.422	.250	12° x 3/8"	.075	.085	7° Dish	122
11856-8	Int.	2.250	.3415	.250 Longer	5.494	.250	12° x 3/8"	.050	.100	7° Dish	145
11854-8	Int.	2.300	.3415	.250 Longer	5.494	.250	12° x 3/8"	.050	.100	7° Dish	147

Big Block Chevrolet Pontiac "Pro Stock" & Dart "Big Chief" Extreme Duty & Severe Duty® Valves 11/32" Stems

Part No.	Type	Head Diameter	Stem Diameter	Installed Height	O/A Length	Tip Length	Underhead Angle/Radius	Margin	Seat Width	Top of Head	Wgt/ Grams
11597-8	Exh.	1.900	.3415	Stock	6.450	.290	15° x 1/2"	.085	.080	9° Dish	143
EXTREME DUTY VALVES											
11581-8	Exh.	1.900	.3415	Stock	6.380	.250	25° x 3/8"	.085	.100	20° Dish	144
11583-8	Exh.	1.940	.3415	Stock	6.400	.250	25° x 3/8"	.085	.100	20° Dish	150
SEVERE DUTY® VALVES											
11580-8	Int.	2.325	.3415	Stock	6.590	.250	10° x 3/8"	.050	.075	5° Dish	165
11582-8	Int.	2.400	.3415	Stock	6.600	.250	10° x 3/8"	.050	.075	5° Dish	168

Big Block Chevrolet Severe Duty® Valves 5/16" (.311") Stem Diameters

These .311" stem valves are ONLY available with Bead Loc® keeper grooves. Bead Loc® valve locks are REQUIRED.

Want a hollow stem Severe Duty® intake? It's as easy as 1-2-3. Refer to Gen II blank P/N 11264H on page 42 to support your custom requirements.



Part No.	Type	Head Diameter	Stem Diameter	Installed Height	O/A Length	Tip Length	Underhead Angle/Radius	Margin	Seat Width	Top of Head	Wgt/ Grams	
12843-8	Exh.	1.880	.3110	Stock	5.422	.250	12° x 3/8"	.075	.100	7° Dish	107	
12815-8	Exh.	1.880	.3110	.100 Longer	5.522	.250	12° x 3/8"	.075	.100	7° Dish	110	
12817-8	Exh.	1.900	.3110	Stock	5.422	.250	12° x 3/8"	.075	.100	7° Dish	108	
12811-8	Exh.	1.900	.3110	.100 Longer	5.522	.250	12° x 3/8"	.075	.100	7° Dish	111	
12803-8	Exh.	1.940	.3110	Stock	5.422	.250	12° x 3/8"	.075	.100	7° Dish	109	
12809-8	Exh.	1.940	.3110	.100 Longer	5.522	.250	12° x 3/8"	.075	.100	7° Dish	112	
12802-8	Int.	2.250	.3110	Stock	5.244	.250	10° x 3/8"	.050	.080	5° Dish	122	
12850-8	Int.	2.250	.3110	.100 Longer	5.344	.250	10° x 3/8"	.050	.080	5° Dish	125	
12850H-8	Int.	2.250	.3110	.100 Longer	5.344	.250	10° x 3/8"	.050	.080	5° Dish	113	
			Hollow Stem									
12856-8	Int.	2.250	.3110	.250 Longer	5.494	.250	10° x 3/8"	.050	.080	5° Dish	128	
12856H-8	Int.	2.250	.3110	.250 Longer	5.494	.250	10° x 3/8"	.050	.080	5° Dish	116	
			Hollow Stem									
12898-8	Int.	2.250	.3110	.350 Longer	5.594	.250	10° x 3/8"	.050	.080	5° Dish	132	
12780-8	Int.	2.300	.3110	Stock	5.244	.250	10° x 3/8"	.050	.080	5° Dish	126	
12842-8	Int.	2.300	.3110	.100 Longer	5.344	.250	10° x 3/8"	.050	.080	5° Dish	128	
12784-8	Int.	2.300	.3110	.200 Longer	5.444	.250	10° x 3/8"	.050	.080	5° Dish	129	
12854-8	Int.	2.300	.3110	.250 Longer	5.494	.250	10° x 3/8"	.050	.080	5° Dish	130	
12878-8	Int.	2.300	.3110	.350 Longer	5.594	.250	10° x 3/8"	.050	.080	5° Dish	133	
12838-8	Int.	2.325	.3110	.250 Longer	5.494	.250	10° x 3/8"	.050	.080	5° Dish	134	
12880-8	Int.	2.350	.3110	.350 Longer	5.594	.250	10° x 3/8"	.050	.080	5° Dish	135	

Need a different length? Head diameter not listed? Prefer a BeadLoc® groove?
See pages 42 & 43 for Gen II blanks to construct a valve to your exact specifications.

STAINLESS VALVES

VALVES

GM Duramax 6.6L Diesel 4 Valve

Extreme Duty & Race Flo Valves

- ▶ XH-432 XtremeAlloy Exhaust Material
- ▶ NK-842 Stainless Intake Material
- ▶ Chrome Stems and Hard Tips
- ▶ Swirl Polished and Fully Machined
- ▶ Single Radius Groove for Factory Locks



These Manley valves are boxed in sets of 8 pieces. Please order two boxes of both intakes and exhausts to fit your engine.

Part No.	Type	Head Diameter	Stem Diameter	Installed Height	O/A Length	Tip Length	Underhead Angle/Radius	Margin	Seat Width	Top of Head	Wgt/ Grams
EXTREME DUTY VALVES											
11609-8	Exh.	1.300	.2735	Stock	4.985	.480	30° x 13/32"	.060	.110	Flat Face	74
RACE FLO VALVES											
11608-8 *	Int.	1.338	.2740	Stock	4.985	.480	25° x 9/32"	.050	.085	Flat Face	67

* Intakes have backcut - .090" x 30°



SoCal Diesel customer Wade Minter and Trippplemax

Buick V-6

Stage 1 and Production Cast Iron Heads Severe Duty® Valves

- ▶ XH-428 Exhaust Material
- ▶ NK-844 Intake Material
- ▶ Chrome Stems and Hard Tips
- ▶ Swirl Polished and Machined
- ▶ Intakes are "Pro Flo" for Improved Flow



Part No.	Type	Head Diameter	Stem Diameter	Installed Height	O / A Length	Tip Length	Underhead Angle / Radius	Margin	Seat Width	Top of Head	Wgt / Grams
11503-6	Exh.	1.500	.3415	Stock	4.725	.270	30° x 7/16"	.075	.090	20° Dish	98
11502-6	Int.	1.710	.3415	Stock	4.730	.270	Pro Flo: 12° x 3/8"	.065	.080	7° Dish	95
11504-6	Int.	1.775	.3415	Stock	4.730	.270	Pro Flo: 12° x 3/8"	.065	.080	7° Dish	97

Oldsmobile 330 - 455

Severe Duty® Valves

- ▶ XH-428 Stainless Exhaust Material
- ▶ NK-844 Stainless Intake Material
- ▶ Hard Tips
- ▶ Swirl Polished
- ▶ Chrome Stems
- ▶ Fully Machined



Part No.	Type	Head Diameter	Stem Diameter	Installed Height	O / A Length	Tip Length	Underhead Angle / Radius	Margin	Seat Width	Top of Head	Wgt / Grams
11547-8	Exh.	1.710	.3415	Stock	4.668	.260	10° x 3/8"	.060	.100	5° Dish	101
11548-8	Int.	2.072	.3415	Stock	4.713	.260	10° x 3/8"	.050	.080	5° Dish	117

Valve P/N's 11547 and 11548 are manufactured with .3415" stem diameters. We recommend that customers check their valve guide size in order to achieve the proper valve stem to guide clearance. Factory sizes may vary depending on the specific motor.

Pontiac 400 - 428 - 455

Race Master & Race Flo Valves

- ▶ XH-426 Stainless Exhaust Material
- ▶ NK-842 Stainless Intake Material
- ▶ Chrome Stems and Hard Tips
- ▶ Swirl Polished and Fully Machined



Part No.	Type	Head Diameter	Stem Diameter	Installed Height	O / A Length	Tip Length	Underhead Angle / Radius	Margin	Seat Width	Top of Head	Wgt / Grams
11353-8	Exh.	1.660	.3415	Stock	5.230	.250	25° x 3/8"	.080	.100	20° Dish	115
11355-8	Exh.	1.770	.3415	Stock	5.100	.250	25° x 3/8"	.080	.100	20° Dish	117
11337-8	Exh.	1.770	.3415	Stock	5.230	.250	25° x 3/8"	.080	.100	20° Dish	123
11364-8	Int.	2.110	.3415	Stock	5.100	.250	Pro Flo 12° x 3/8"	.050	.100	7° Dish	114
11352-8	Int.	2.110	.3415	Stock	5.215	.250	Pro Flo 12° x 3/8"	.050	.100	7° Dish	118

Valve P/N's 11352 and 11353 fit Edelbrock 72cc cylinder heads. Both intakes have 30° seats.

Need a different length? Head diameter not listed? Prefer a BeadLoc® groove?
See pages 42 & 43 for Gen II blanks to construct a valve to your exact specifications.

STAINLESS VALVES

VALVES

Chrysler / Dodge 5.7L & 6.1L Hemi Race Flo & Race Master Valves

- ▶ XH-426 Stainless Exhaust Material
- ▶ NK-842 Stainless Intake Material
- ▶ Swirl Polished & Fully Machined
- ▶ Improved Flow with "Pro Flo" Underhead

Must use factory locks with triple grooves and use Manley's Bead Loc® P/N 13093-16 with the Bead Loc® single radius groove.



Part No.	Type	Head Diameter	Stem Diameter	Installed Height	O / A Length	Tip Length	Underhead Angle / Radius	Margin	Seat Width	Top of Head	Wgt / Grams
Chrysler HEMI 5.7L (Thru 2008) w/ TRIPLE GROOVE											
11665-8	Exh.	1.555"	.3125"	Stock	4.845"	.120	25° x 1/2"	.065	.100	20° Dish	88
11667-8	Exh.	1.575"	.3125"	Stock	4.845"	.120	25° x 1/2"	.065	.100	20° Dish	90
11664-8	Int.	2.000"	.3125"	Stock	4.955"	.120	Pro Flo: 10° x 5/16"	.050	.085	5° Dish	103
11666-8	Int.	2.020"	.3125"	Stock	4.955"	.120	Pro Flo: 10° x 5/16"	.050	.085	5° Dish	104
11666H-8	Int.	2.020"	.3125"	Stock	4.955"	.120	Pro Flo: 10° x 5/16"	.050	.085	5° Dish	92
Hollow Stem											
Chrysler HEMI 5.7L (Thru 2008) w/ BEAD LOC® GROOVE											
11665B-8	Exh.	1.555"	.3125"	Stock	4.845"	.135	25° x 1/2"	.065	.100	20° Dish	88
11667B-8	Exh.	1.575"	.3125"	Stock	4.845"	.135	25° x 1/2"	.065	.100	20° Dish	90
11664B-8	Int.	2.000"	.3125"	Stock	4.955"	.135	Pro Flo: 10° x 5/16"	.050	.085	5° Dish	103
11666B-8	Int.	2.020"	.3125"	Stock	4.955"	.135	Pro Flo: 10° x 5/16"	.050	.085	5° Dish	104
11666HB-8	Int.	2.020"	.3125"	Stock	4.955"	.135	Pro Flo: 10° x 5/16"	.050	.085	5° Dish	92
Hollow Stem											
Chrysler HEMI 5.7L (2009 - Up) w/ TRIPLE GROOVE											
11695-8	Exh.	1.555"	.3125"	Stock	5.125"	.120	25° x 1/2"	.065	.100	20° Dish	95
11697-8	Exh.	1.575"	.3125"	Stock	5.125"	.120	25° x 1/2"	.065	.100	20° Dish	97
11694-8	Int.	2.050"	.3125"	Stock	5.176"	.120	Pro Flo: 10° x 5/16"	.050	.085	5° Dish	111
11696-8	Int.	2.080"	.3125"	Stock	5.176"	.120	Pro Flo: 10° x 5/16"	.050	.085	5° Dish	113
11696H-8	Int.	2.080"	.3125"	Stock	5.176"	.120	Pro Flo: 10° x 5/16"	.050	.085	5° Dish	101
Hollow Stem											
Chrysler HEMI 5.7L (2009 - Up) w/ BEAD LOC® GROOVE											
11695B-8	Exh.	1.555"	.3125"	Stock	5.125"	.135	25° x 1/2"	.065	.100	20° Dish	95
11697B-8	Exh.	1.575"	.3125"	Stock	5.125"	.135	25° x 1/2"	.065	.100	20° Dish	97
11694B-8	Int.	2.050"	.3125"	Stock	5.176"	.135	Pro Flo: 10° x 5/16"	.050	.085	5° Dish	111
11696B-8	Int.	2.080"	.3125"	Stock	5.176"	.135	Pro Flo: 10° x 5/16"	.050	.085	5° Dish	113
11696HB-8	Int.	2.080"	.3125"	Stock	5.176"	.135	Pro Flo: 10° x 5/16"	.050	.085	5° Dish	101
Hollow Stem											
Chrysler HEMI 6.1L w/ TRIPLE GROOVE											
11669-8	Exh.	1.595"	.3125"	Stock	4.925"	.120	25° x 1/2"	.065	.100	20° Dish	91
11671-8	Exh.	1.625"	.3125"	Stock	4.925"	.120	25° x 1/2"	.065	.100	20° Dish	93
11668-8	Int.	2.080"	.3125"	Stock	4.990"	.120	Pro Flo: 10° x 5/16"	.050	.085	5° Dish	108
11670-8	Int.	2.100"	.3125"	Stock	4.990"	.120	Pro Flo: 10° x 5/16"	.050	.085	5° Dish	111
11670H-8	Int.	2.100"	.3125"	Stock	4.990"	.120	Pro Flo: 10° x 5/16"	.050	.085	5° Dish	99
Hollow Stem											
Chrysler HEMI 6.1L w/ BEAD LOC® GROOVE											
11669B-8	Exh.	1.595"	.3125"	Stock	4.925"	.135	25° x 1/2"	.065	.100	20° Dish	91
11671B-8	Exh.	1.625"	.3125"	Stock	4.925"	.135	25° x 1/2"	.065	.100	20° Dish	93
11668B-8	Int.	2.080"	.3125"	Stock	4.990"	.135	Pro Flo: 10° x 5/16"	.050	.085	5° Dish	108
11670B-8	Int.	2.100"	.3125"	Stock	4.990"	.135	Pro Flo: 10° x 5/16"	.050	.085	5° Dish	111
11670HB-8	Int.	2.100"	.3125"	Stock	4.990"	.135	Pro Flo: 10° x 5/16"	.050	.085	5° Dish	99
Hollow Stem											

For the 5.7L exhaust valves, Manley Performance recommends that customers check their valve guide size in order to achieve the proper valve stem to guide clearance. Guides may need to be honed when replacing valves.

Chrysler / Dodge 6.4L Hemi

Race Flo & Race Master Valves

- ▶ XH-426 Stainless Exhaust Material
- ▶ NK-842 Stainless Intake Material
- ▶ Swirl Polished & Fully Machined
- ▶ Improved Flow with "Pro Flo" Underhead



Must use factory locks with triple grooves and use Manley's Bead Loc® P/N 13093-16 with the Bead Loc® single radius groove.

Part No.	Type	Head Diameter	Stem Diameter	Installed Height	O/A Length	Tip Length	Underhead Angle/Radius	Margin	Seat Width	Top of Head	Wgt/ Grams
CHRYSLER HEMI 6.4L (2011 - Up) w/ TRIPLE GROOVE											
12331-8	Exh.	1.654"	.3125"	Stock	5.100"	.120	25° x 1/2"	.080	.100	20° Dish	103
12333-8	Exh.	1.675"	.3125"	Stock	5.100"	.120	25° x 1/2"	.080	.100	20° Dish	104
12330-8*	Int.	2.140"	.3125"	Stock	5.135"	.120	Pro Flo: 10° x 5/16"	.050	.080	5° Dish	127
12332-8*	Int.	2.180"	.3125"	Stock	5.135"	.120	Pro Flo: 10° x 5/16"	.050	.080	5° Dish	129
12332H-8*	Int.	2.180"	.3125"	Stock	5.135"	.120	Pro Flo: 10° x 5/16" Hollow Stem	.050	.080	5° Dish	116

CHRYSLER HEMI 6.4L (2011 - Up) w/ BEAD LOC® GROOVE

12331B-8	Exh.	1.654"	.3125"	Stock	5.100"	.135	25° x 1/2"	.080	.100	20° Dish	103
12333B-8	Exh.	1.675"	.3125"	Stock	5.100"	.135	25° x 1/2"	.080	.100	20° Dish	104
12330B-8*	Int.	2.140"	.3125"	Stock	5.135"	.135	Pro Flo: 10° x 5/16"	.050	.080	5° Dish	127
12332B-8*	Int.	2.180"	.3125"	Stock	5.135"	.135	Pro Flo: 10° x 5/16"	.050	.080	5° Dish	129
12332HB-8*	Int.	2.180"	.3125"	Stock	5.135"	.135	Pro Flo: 10° x 5/16" Hollow Stem	.050	.080	5° Dish	116

* Intakes have backcut - .055" x 30°

Dodge Viper V-10 Up To 2010

Race Master Valves

- ▶ XH-426 Stainless Exhaust Material
- ▶ Swirl Polished
- ▶ Chrome Stems
- ▶ Bead Loc® keeper grooves for use with the factory valve locks up to 2006 or Manley .3110" stem Bead Loc® valve locks.
- ▶ NK-842 Stainless Intake Material
- ▶ Fully Machined
- ▶ Hard Tips



Part No.	Type	Head Diameter	Stem Diameter	Installed Height	O/A Length	Tip Length	Underhead Angle/Radius	Margin	Seat Width	Top of Head	Wgt/ Grams
11641-10	Exh.	1.580	.3110	Stock	5.770	.110	18° x 1/2"	.075	.100	12° Dish	101
11643-10	Exh.	1.600	.3110	Stock	5.770	.110	18° x 1/2"	.075	.100	12° Dish	102
11645-10	Exh.	1.600	.3110	.100 Longer	5.870	.110	18° x 1/2"	.075	.100	12° Dish	103
11647-10	Exh.	1.600	.3110	.200 Longer	5.970	.110	18° x 1/2"	.075	.100	12° Dish	104
11642-10	Int.	1.920	.3110	Stock	5.728	.110	12° x 3/8"	.050	.080	7° Dish	105
11644-10	Int.	2.020	.3110	Stock	5.728	.110	12° x 3/8"	.050	.080	7° Dish	112
11646-10	Int.	2.020	.3110	.100 Longer	5.828	.110	12° x 3/8"	.050	.080	7° Dish	113
11648-10	Int.	2.020	.3110	.200 Longer	5.928	.110	12° x 3/8"	.050	.080	7° Dish	114
11660-10	Int.	2.055	.3110	.100 Longer	5.828	.110	12° x 3/8"	.050	.080	7° Dish	114

Need a different length? Head diameter not listed? Prefer a BeadLoc® groove?
See pages 42 & 43 for Gen II blanks to construct a valve to your exact specifications.

STAINLESS VALVES

VALVES

Chrysler 340 - 360

Race Series Valves & Severe Duty® "Pro Flo" Valves

- ▶ Chrome Stems and Hard Tips
- ▶ Swirl Polished and Fully Machined
- ▶ W-2 Valves are "Pro Flo" Underhead



Part No.	Type	Head Diameter	Stem Diameter	Installed Height	O / A Length	Tip Length	Underhead Angle / Radius	Margin	Seat Width	Top of Head	Wgt / Grams
W-2 LATE MODEL STOCK P/N P5249769 CYLINDER HEAD											
11703-8	Exh.	1.600	.3415	Stock	5.255	.290	Pro Flo: 15° x 1/2"	.095	.080	17° Dish	111
11702-8	Int.	2.020	.3415	Stock	5.240	.290	Pro Flo: 12° x 3/8"	.065	.080	7° Dish	125
P/N 11703-8 exhaust is a Race-Flo. P/N 11702-8 intake is a Severe Duty Pro-Flo.											
W-2 CYLINDER HEAD SEVERE DUTY® "PRO FLO" VALVES											
11549-8	Exh.	1.600	.3715	.150 Longer	5.075	.220	Pro Flo: 12° x 3/8"	.085	.100	7° Dish	107
11550-8	Int.	2.020	.3720	.150 Longer	5.050	.220	Pro Flo: 12° x 7/16"	.050	.080	7° Dish	123
STOCK CYLINDER HEAD RACE MASTER VALVES											
11781-8	Exh.	1.600	.3715	Stock	4.970	.225	15° x 1/2"	.080	.100	9° Dish	104
11783-8	Exh.	1.625	.3715	Stock	4.970	.225	15° x 1/2"	.080	.100	9° Dish	105
11782-8	Int.	2.020	.3715	Stock	4.980	.225	12° x 3/8"	.050	.080	7° Dish	118

Chrysler 361 - 383 - 426 Wedge - 440

Race Flo & Race Master Valves



Part No.	Type	Head Diameter	Stem Diameter	Installed Height	O / A Length	Tip Length	Underhead Angle / Radius	Margin	Seat Width	Top of Head	Wgt / Grams
11859-8	Exh.	1.740	.3720	Stock	4.908	.275	Pro Flo: 10° x 3/8"	.085	.100	5° Dish	116
11307-8	Exh.	1.740	.3715	.100 Longer	5.010	.275	15° x 1/2"	.080	.100	9° Dish	121
11891-8	Exh.	1.810	.3720	Stock	4.908	.275	Pro Flo: 10° x 3/8"	.085	.100	5° Dish	121
11309-8	Exh.	1.810	.3715	.100 Longer	5.010	.275	15° x 1/2"	.080	.100	9° Dish	126
11892-8	Int.	2.080	.3720	Stock	4.873	.275	Pro Flo: 10° x 3/8"	.050	.085	5° Dish	122
11308-8	Int.	2.080	.3715	.100 Longer	5.000	.275	12° x 3/8"	.060	.080	7° Dish	125
11890-8	Int.	2.140	.3720	Stock	4.873	.275	Pro Flo: 10° x 3/8"	.050	.085	5° Dish	126
11314-8	Int.	2.140	.3715	.100 Longer	5.000	.275	12° x 3/8"	.060	.080	7° Dish	131
11388-8	Int.	2.180	.3715	.100 Longer	5.000	.275	12° x 3/8"	.060	.080	7° Dish	134

Severe Duty® "Pro Flo" Valves

Part No.	Type	Head Diameter	Stem Diameter	Installed Height	O / A Length	Tip Length	Underhead Angle / Radius	Margin	Seat Width	Top of Head	Wgt / Grams
11841-8	Exh.	1.740	.3720	Stock	4.908	.275	Pro Flo: 10° x 3/8"	.085	.100	5° Dish	116
11839-8	Exh.	1.810	.3720	Stock	4.908	.275	Pro Flo: 10° x 3/8"	.085	.100	5° Dish	121
11833-8	Exh.	1.880	.3720	Stock	4.908	.275	Pro Flo: 10° x 3/8"	.085	.100	5° Dish	126
11876-8	Int.	2.080	.3720	Stock	4.873	.275	Pro Flo: 12° x 3/8"	.050	.080	7° Dish	122
11834-8	Int.	2.140	.3720	Stock	4.873	.275	Pro Flo: 12° x 3/8"	.050	.080	7° Dish	126

Chrysler 440-1

"Indy Cylinder Heads"

Race Master Valves & Severe Duty® Valves

- ▶ Swirl Polished
- ▶ Fully Machined
- ▶ Chrome Stems
- ▶ Hard Tips

Manufactured specifically for Indy Cylinder Head's own 440-1 aluminum or cast iron head.



Part No.	Type	Head Diameter	Stem Diameter	Installed Height	O/A Length	Tip Length	Underhead Angle/Radius	Margin	Seat Width	Top of Head	Wgt/ Grams
RACE MASTER VALVES											
11381-8	Exh.	1.810	.3415	Stock	5.400	.250	10° x 3/8"	.075	.100	6° Dish	118
11380-8	Int.	2.190	.3415	Stock	5.344	.250	10° x 3/8"	.050	.080	5° Dish	134
11382-8	Int.	2.250	.3415	Stock	5.344	.250	10° x 3/8"	.050	.080	5° Dish	136
SEVERE DUTY VALVES											
11813-8	Exh.	1.810	.3415	Stock	5.369	.250	12° x 3/8"	.075	.085	7° Dish	115
11822-8	Int.	2.190	.3415	Stock	5.344	.250	12° x 3/8"	.050	.080	7° Dish	140
11850-8	Int.	2.250	.3415	Stock	5.344	.250	12° x 3/8"	.050	.100	7° Dish	142

Chrysler 426 Hemi

Race Master & Severe Duty® Valves

- ▶ XH-426 Race Master Stainless Exhaust Material
- ▶ NK-844 Severe Duty® Stainless Intake Material
- ▶ NK-842 Race Master Stainless Intake Material
- ▶ Chrome Stems and Hard Tips
- ▶ Swirl Polished and Fully Machined

"B" suffix indicates a Bead Loc® keeper groove. Bead Loc® valve locks are required.



Part No.	Type	Head Diameter	Stem Diameter	Installed Height	O/A Length	Tip Length	Underhead Angle/Radius	Margin	Seat Width	Top of Head	Wgt/ Grams
RACE MASTER VALVES											
11315-8	Exh.	1.900	.3075	Stock	4.855	.200	22° x 3/8"	.070	.100	18° Dish	104
11315B-8	Exh.	1.900	.3075	Stock	4.855	.200	22° x 3/8"	.070	.100	18° Dish	104
11317-8	Exh.	1.940	.3075	Stock	4.865	.200	22° x 3/8"	.070	.100	18° Dish	107
11317B-8	Exh.	1.940	.3075	Stock	4.865	.200	22° x 3/8"	.070	.100	18° Dish	107
11901-8	Exh.	1.900	.3100	Stock	4.915	.250	22° x 1/4"	.075	.100	17° Dish	132
11905-8	Exh.	1.940	.3100	Stock	4.915	.250	22° x 1/4"	.075	.100	17° Dish	133
11516-8	Int.	2.200	.3100	Stock	5.490	.250	24° x 3/4"	.060	.080	19° Dish	128
11518-8	Int.	2.250	.3100	Stock	5.490	.250	24° x 3/4"	.060	.080	19° Dish	131
SEVERE DUTY VALVES											
11902-8	Int.	2.200	.3085	Stock	5.405	.200	24° x 3/4"	.060	.095	20° Dish	133
11902B-8	Int.	2.200	.3085	Stock	5.405	.200	24° x 3/4"	.060	.095	20° Dish	133
11904-8	Int.	2.250	.3085	Stock	5.424	.200	24° x 3/4"	.060	.095	20° Dish	136
11904B-8	Int.	2.250	.3085	Stock	5.424	.200	24° x 3/4"	.060	.095	20° Dish	136
11906-8	Int.	2.250	.3085	.050 Longer	5.474	.200	24° x 3/4"	.060	.095	20° Dish	137
11906B-8	Int.	2.250	.3085	.050 Longer	5.474	.200	24° x 3/4"	.060	.095	20° Dish	137
11908-8	Int.	2.250	.3085	.100 Longer	5.524	.200	24° x 3/4"	.060	.095	20° Dish	138
11908B-8	Int.	2.250	.3085	.100 Longer	5.524	.200	24° x 3/4"	.060	.095	20° Dish	138

Top Fuel & Funny Car

Extreme Duty Exhaust Valves

- ▶ XH-432 XtremeAlloy Material
- ▶ Chrome Stems and Swirl Polished
- ▶ Hard Tips

Part No.	Type	Head Diameter	Stem Diameter	Installed Height	O/A Length	Tip Length	Underhead Angle/Radius	Margin	Seat Width	Top of Head	Wgt/ Grams
11837-8	Exh.	1.950	.3715	.100 Longer	5.020	.250	22° x 1/2"	.100	.100	15° Dish	166
11729B-8**	Exh.	1.950	.3715	.200 Longer	5.120	.250	22° x 1/2"	.100	.100	15° Dish	169
11855-8	Exh.	2.000	.3715	.100 Longer	5.020	.250	22° x 1/2"	.080	.125	15° Dish	165
11895-8*	Exh.	2.000	.3715	*	5.315	*	22° x 1/2"	.118	.110	13° Dish	169

* Valve 11895 is stocked at the O/A length listed above with no keeper grooves.

All valves above except 11855 have a 55° seat angle.

Please specify the overall length and groove location you require. There is no charge for these machining operations.

** Valve 11729B has a Bead Loc® keeper groove. Bead Loc® valve locks are required.

Ford 2.3L EcoBoost Race Flo Valves & Extreme Duty Valves

- ▶ XH-432 XtremeAlloy Exhaust Material
- ▶ NK-842 Stainless Intake Material
- ▶ Chrome Stems and Hard Tips
- ▶ Swirl Polished and Fully Machined
- ▶ Improved Flow with "Pro Flo" Underhead
- ▶ Factory single radius keeper grooves



Part No.	Type	Head Diameter	Stem Diameter	Installed Height	O/A Length	Tip Length	Underhead Angle/Radius	Margin	Seat Width	Top of Head	Wgt/ Grams
EXTREME DUTY VALVES											
11197-8	Exh.	30.0mm	5.46mm / .2150"	Stock	104.75mm	3.75mm	25° x 11/32"	.050"	.100"	Flat Face	45
11199-8	Exh.	30.5mm	5.46mm / .2150"	Stock	104.75mm	3.75mm	25° x 11/32"	.050"	.100"	Flat Face	46
RACE MASTER VALVES											
11196-8	Int.	32.5mm	5.48mm / .2157"	Stock	103.55mm	4.00mm	Pro Flo: 22° x 5/16"	.050"	.100"	17° Dish	43
11198-8	Int.	33.0mm	5.48mm / .2157"	Stock	103.55mm	4.00mm	Pro Flo: 22° x 5/16"	.050"	.100"	17° Dish	44

Ford 4.6L & 5.4L SOHC 2 Valve Race Master Valves

Must use factory locks for triple grooves and use Manley's Bead Loc® P/N 13089-16 with the Bead Loc® single radius groove. We can also custom build Extreme Duty exhaust valves from our P/N 11281 GEN II blank stainless valve on page 42.



Part No.	Type	Head Diameter	Stem Diameter	Installed Height	O/A Length	Tip Length	Underhead Angle/Radius	Margin	Seat Width	Top of Head	Wgt/ Grams
1999 AND LATER w/ TRIPLE GROOVE											
11637-8	Exh.	36.0mm	.2740	Stock	4.650	.470	15° x 1/2"	.060	.080	9° Dish	66
11639-8	Exh.	37.0mm	.2740	Stock	4.650	.470	15° x 1/2"	.060	.080	9° Dish	68
11636-8	Int.	44.5mm	.2750	Stock	4.705	.470	10° x 3/8"	.050	.080	5° Dish	76
11640-8	Int.	45.5mm	.2750	Stock	4.705	.470	10° x 3/8"	.050	.080	5° Dish	78
1999 AND LATER w/ BEAD LOC® GROOVE											
11637B-8	Exh.	36.0mm	.2740	Stock	4.650	.485	15° x 1/2"	.060	.080	9° Dish	66
11639B-8	Exh.	37.0mm	.2740	Stock	4.650	.485	15° x 1/2"	.060	.080	9° Dish	68
11636B-8	Int.	44.5mm	.2750	Stock	4.705	.485	10° x 3/8"	.050	.080	5° Dish	76
11640B-8	Int.	45.5mm	.2750	Stock	4.705	.485	10° x 3/8"	.050	.080	5° Dish	78
1996 - 1998 w/ TRIPLE GROOVE											
11635-8	Exh.	34.0mm	.2740	Stock	4.650	.470	15° x 1/2"	.060	.080	9° Dish	62
11637-8*	Exh.	36.0mm	.2740	Stock	4.650	.470	15° x 1/2"	.060	.080	9° Dish	66
11634-8	Int.	44.5mm	.2750	Stock	4.630	.470	10° x 3/8"	.050	.080	5° Dish	77
11638-8*	Int.	46.83mm	.2750	Stock	4.630	.470	10° x 3/8"	.050	.080	5° Dish	82
1996 - 1998 w/ BEAD LOC® GROOVE											
11635B-8	Exh.	34.0mm	.2740	Stock	4.650	.485	15° x 1/2"	.060	.080	9° Dish	62
11637B-8*	Exh.	36.0mm	.2740	Stock	4.650	.485	15° x 1/2"	.060	.080	9° Dish	66
11634B-8	Int.	44.5mm	.2750	Stock	4.630	.485	10° x 3/8"	.050	.080	5° Dish	77
11638B-8*	Int.	46.83mm	.2750	Stock	4.630	.485	10° x 3/8"	.050	.080	5° Dish	82

* Part numbers 11637-8, 11637B-8, 11638-8 and 11638B-8 are for the Ford Racing M-6049-D46 cylinder head.

Ford 4.6L & 5.4L SOHC 3 Valve

Race Master Valves & Extreme Duty Valves

Must use factory locks for triple grooves and use Manley's Bead Loc® P/N 13088-24 with the Bead Loc® single radius groove. These Manley valves are boxed in sets of 8 pieces. Please order two boxes of intakes and one box of exhausts to fit your engine.



Part No.	Type	Head Diameter	Stem Diameter	Installed Height	O/A Length	Tip Length	Underhead Angle/Radius	Margin	Seat Width	Top of Head	Wgt/ Grams
EXTREME DUTY VALVES w/ TRIPLE GROOVE											
11631-8	Exh.	37.5mm	.2345	Stock	4.585	.380	25° x 11/32"	.080	.100	20° Dish	68
11633-8	Exh.	38.5mm	.2345	Stock	4.585	.380	25° x 11/32"	.080	.100	20° Dish	70
EXTREME DUTY VALVES w/ BEAD LOC® GROOVE											
11631B-8	Exh.	37.5mm	.2345	Stock	4.585	.395	25° x 11/32"	.080	.100	20° Dish	68
11633B-8	Exh.	38.5mm	.2345	Stock	4.585	.395	25° x 11/32"	.080	.100	20° Dish	70
RACE MASTER VALVES w/ TRIPLE GROOVE											
11630-8	Int.	34mm	.2355	Stock	4.620	.315	12° x 5/16"	.065	.100	8° Dish	53
11632-8	Int.	35mm	.2355	Stock	4.620	.315	12° x 5/16"	.065	.100	8° Dish	54
RACE MASTER VALVES w/ BEAD LOC® GROOVE											
11630B-8	Int.	34mm	.2355	Stock	4.620	.330	12° x 5/16"	.065	.100	8° Dish	53
11632B-8	Int.	35mm	.2355	Stock	4.620	.330	12° x 5/16"	.065	.100	8° Dish	54

Ford 4.6L & 5.4L DOHC 4 Valve

Race Master Valves

Must use factory locks for triple grooves and use Manley's Bead Loc® P/N 13089-32 with the Bead Loc® single radius groove.

These Manley valves are boxed in sets of 8 pieces. Please order two boxes of both intakes and exhausts to fit your engine.

We can also custom build Extreme Duty exhaust valves from our P/N 11281 GEN II blank stainless valve on page 42.



Part No.	Type	Head Diameter	Stem Diameter	Installed Height	O/A Length	Tip Length	Underhead Angle/Radius	Margin	Seat Width	Top of Head	Wgt/ Grams
TRIPLE GROOVE											
11615-8	Exh.	30mm	.2740	Stock	4.587	.425	15° x 1/2"	.050	.080	9° Dish	53
11617-8	Exh.	31mm	.2740	Stock	4.587	.425	15° x 1/2"	.050	.080	9° Dish	55
11616-8	Int.	37mm	.2750	Stock	5.339	.620	10° x 3/8"	.045	.080	5° Dish	68
11618-8	Int.	38mm	.2750	Stock	5.339	.620	10° x 3/8"	.045	.080	5° Dish	70
BEAD LOC® GROOVE											
11615B-8	Exh.	30mm	.2740	Stock	4.587	.440	15° x 1/2"	.050	.080	9° Dish	53
11617B-8	Exh.	31mm	.2740	Stock	4.587	.440	15° x 1/2"	.050	.080	9° Dish	55
11616B-8	Int.	37mm	.2750	Stock	5.339	.635	10° x 3/8"	.045	.080	5° Dish	68
11618B-8	Int.	38mm	.2750	Stock	5.339	.635	10° x 3/8"	.045	.080	5° Dish	70

STAINLESS VALVES

VALVES

Ford "Coyote" 5.0L Gen I/II DOHC 4 Valve Race Master & Extreme Duty Valves

Must use factory locks for triple grooves and use Manley's Bead Loc® P/N 13086-32 with the Bead Loc® single radius groove.
These Manley valves are boxed in sets of 8 pieces. Please order two boxes of both intakes and exhausts to fit your engine.



Part No.	Type	Head Diameter	Stem Diameter	Installed Height	O/A Length	Tip Length	Underhead Angle/Radius	Margin	Seat Width	Top of Head	Wgt/ Grams
RACE MASTER VALVES w/ TRIPLE GROOVE											
11623-8	Exh.	31mm	.2345	Stock	4.274	.305	30° x 11/32"	.050	.080	25° Dish	44
11625-8	Exh.	31.5mm	.2345	Stock	4.274	.305	30° x 11/32"	.050	.080	25° Dish	45
11627-8	Exh.	32mm	.2345	Stock	4.274	.305	30° x 11/32"	.050	.080	25° Dish	46
EXTREME DUTY VALVES w/ TRIPLE GROOVE											
12623-8	Exh.	31mm	.2345	Stock	4.274	.305	25° x 11/32"	.050	.080	20° Dish	46
12625-8	Exh.	31.5mm	.2345	Stock	4.274	.305	25° x 11/32"	.050	.080	20° Dish	47
12627-8	Exh.	32mm	.2345	Stock	4.274	.305	25° x 11/32"	.050	.080	20° Dish	48
RACE MASTER VALVES w/ TRIPLE GROOVE											
11622-8*	Int.	37mm	.2355	Stock	4.722	.365	10° x 5/16"	.045	.080	5° Dish	54
11624-8*	Int.	37.5mm	.2355	Stock	4.722	.365	10° x 5/16"	.045	.080	5° Dish	55
11626-8*	Int.	38mm	.2355	Stock	4.722	.365	10° x 5/16"	.045	.080	5° Dish	56
RACE MASTER VALVES w/ BEAD LOC® GROOVE											
11623B-8	Exh.	31mm	.2345	Stock	4.274	.320	30° x 11/32"	.050	.080	25° Dish	44
11625B-8	Exh.	31.5mm	.2345	Stock	4.274	.320	30° x 11/32"	.050	.080	25° Dish	45
11627B-8	Exh.	32mm	.2345	Stock	4.274	.320	30° x 11/32"	.050	.080	25° Dish	46
EXTREME DUTY VALVES w/ BEAD LOC® GROOVE											
12623B-8	Exh.	31mm	.2345	Stock	4.274	.320	25° x 11/32"	.050	.080	20° Dish	46
12625B-8	Exh.	31.5mm	.2345	Stock	4.274	.320	25° x 11/32"	.050	.080	20° Dish	47
12627B-8	Exh.	32mm	.2345	Stock	4.274	.320	25° x 11/32"	.050	.080	20° Dish	48
RACE MASTER VALVES w/ BEAD LOC® GROOVE											
11622B-8*	Int.	37mm	.2355	Stock	4.722	.380	10° x 5/16"	.045	.080	5° Dish	54
11624B-8*	Int.	37.5mm	.2355	Stock	4.722	.380	10° x 5/16"	.045	.080	5° Dish	55
11626B-8*	Int.	38mm	.2355	Stock	4.722	.380	10° x 5/16"	.045	.080	5° Dish	56

* Intakes have backcut - .050" x 30°



Travis Akins powered by Modular Head Shop

Ford "Raptor" 6.2L SOHC 2 Valve Race Master Valves

Must use factory locks for triple grooves and use Manley's Bead Loc® P/N 13087-16 with the Bead Loc® single radius groove.

Part No.	Type	Head Diameter	Stem Diameter	Installed Height	O/A Length	Tip Length	Underhead Angle/Radius	Margin	Seat Width	Top of Head	Wgt/ Grams
TRIPLE GROOVE											
11611-8	Exh.	42mm	.3120	Stock	5.356	.110	25° x 7/16"	.060	.100	20° Dish	99
11613-8	Exh.	43mm	.3120	Stock	5.356	.110	25° x 7/16"	.060	.100	20° Dish	100
11610-8*	Int.	53.5mm	.3122	Stock	5.424	.110	12° x 5/16"	.050	.080	7° Dish	120
11612-8*	Int.	54.5mm	.3122	Stock	5.424	.110	12° x 5/16"	.050	.080	7° Dish	123
11612H-8*	Int.	54.5mm	.3122 Hollow Stem	Stock	5.424	.110	12° x 5/16"	.050	.080	7° Dish	109
BEAD LOC® GROOVE											
11611B-8	Exh.	42mm	.3120	Stock	5.356	.125	25° x 7/16"	.060	.100	20° Dish	99
11613B-8	Exh.	43mm	.3120	Stock	5.356	.125	25° x 7/16"	.060	.100	20° Dish	100
11610B-8*	Int.	53.5mm	.3122	Stock	5.424	.125	12° x 5/16"	.050	.080	7° Dish	120
11612B-8*	Int.	54.5mm	.3122	Stock	5.424	.125	12° x 5/16"	.050	.080	7° Dish	123
11612HB-8*	Int.	54.5mm	.3122 Hollow Stem	Stock	5.424	.125	12° x 5/16"	.050	.080	7° Dish	109

* Intakes have backcut - .050" x 30°

Ford 289 - 302 - 351W Budget Performance, Street Flo, & Race Flo Valves

- ▶ Chrome Stems and Hard Tips
- ▶ Swirl Polished and Fully Machined



Part No.	Type	Head Diameter	Stem Diameter	Installed Height	O/A Length	Tip Length	Underhead Angle/Radius	Margin	Seat Width	Top of Head	Wgt/ Grams
BUDGET PERFORMANCE VALVES FOR USE WITH NON-RAIL OR ROLLER ROCKERS											
10549-8*	Exh.	1.600	.3415	Stock	4.911	.250	15° x 1/2"	.060	.100	10° Dish	101
10548-8*	Int.	1.900	.3415	Stock	4.911	.250	10° x 3/8"	.050	.080	6° Dish	105
10576-8*	Int.	1.940	.3415	Stock	4.911	.250	10° x 3/8"	.050	.080	6° Dish	116
10550-8*	Int.	2.020	.3415	Stock	4.911	.250	10° x 3/8"	.050	.080	6° Dish	109
RACE FLO VALVES FOR USE WITH NON RAIL OR ROLLER ROCKERS											
11531-8*	Exh.	1.600	.3415	Stock	4.911	.250	Pro Flo: 12° x 3/8"	.060	.100	7° Dish	94
11532-8*	Int.	1.940	.3415	Stock	4.911	.250	Pro Flo: 10° x 3/8"	.050	.080	5° Dish	107
11566-8*	Int.	2.020	.3415	Stock	4.911	.250	Pro Flo: 12° x 3/8"	.050	.080	5° Dish	113
STREET FLO VALVES FOR USE WITH RAIL TYPE ROCKERS											
10723-8	Exh.	1.465	.3415	Stock	5.080	.395	Pro Flo: 12° x 3/8"	.060	.100	7° Dish	93
10775-8	Exh.	1.550	.3415	Stock	5.080	.395	Pro Flo: 12° x 3/8"	.060	.100	7° Dish	94
10778-8	Int.	1.850	.3420	Stock	5.075	.395	Pro Flo: 12° x 3/8"	.050	.080	7° Dish	105
RACE FLO VALVES FOR USE WITH RAIL TYPE ROCKERS											
11523-8	Exh.	1.465	.3415	Stock	5.080	.395	Pro Flo: 12° x 3/8"	.060	.100	5° Dish	93
11575-8	Exh.	1.550	.3415	Stock	5.080	.395	Pro Flo: 12° x 3/8"	.060	.100	5° Dish	94
11889-8	Exh.	1.600	.3415	Stock	5.080	.395	Pro Flo: 15° x 1/2"	.060	.100	9° Dish	96
11572-8	Int.	1.785	.3420	Stock	5.075	.395	Pro Flo: 12° x 3/8"	.050	.080	5° Dish	104
11578-8	Int.	1.850	.3420	Stock	5.075	.395	Pro Flo: 12° x 3/8"	.050	.080	5° Dish	105
11888-8	Int.	1.940	.3420	Stock	5.075	.395	Pro Flo: 12° x 3/8"	.050	.080	5° Dish	110

* Ford valves with .250" tips must use non-rail type rockers or roller rockers.

Ford S.V.O. straight stem equivalents: P/N 11575 = M-6505-G302 P/N 11578 = M-6507-G302

Ford 351C

Race Master Valves & Severe Duty® Valves

- ▶ Chrome Stems and Hard Tips
- ▶ Swirl Polished and Fully Machined



Part No.	Type	Head Diameter	Stem Diameter	Installed Height	O/A Length	Tip Length	Underhead Angle/Radius	Margin	Seat Width	Top of Head	Wgt/ Grams
RACE MASTER VALVES											
11873-8	Exh.	1.710	.3415	Stock	5.042	.250	12° x 3/8"	.060	.100	7° Dish	104
11872-8	Int.	2.190	.3415	Stock	5.244	.250	10° x 3/8"	.050	.080	5° Dish	129
11874-8	Int.	2.250	.3415	Stock	5.244	.250	10° x 3/8"	.050	.080	5° Dish	130
SEVERE DUTY® VALVES											
11807-8	Exh.	1.655	.3415	Stock	5.067	.220	12° x 3/8"	.085	.085	7° Dish	102
11853-8	Exh.	1.655	.3415	.100 Longer	5.167	.250	12° x 3/8"	.085	.085	7° Dish	105
11805-8	Exh.	1.710	.3415	Stock	5.067	.220	12° x 3/8"	.085	.085	7° Dish	108
11857-8	Exh.	1.710	.3415	.100 Longer	5.167	.250	12° x 3/8"	.085	.085	7° Dish	111
11800-8	Int.	2.190	.3415	Stock	5.244	.250	12° x 3/8"	.050	.080	7° Dish	139
11822-8	Int.	2.190	.3415	.100 Longer	5.344	.250	12° x 3/8"	.050	.080	7° Dish	140
11802-8	Int.	2.250	.3415	Stock	5.244	.250	12° x 3/8"	.050	.100	7° Dish	139
11850-8	Int.	2.250	.3415	.100 Longer	5.344	.250	12° x 3/8"	.050	.100	7° Dish	142

Ford SVO "Sportsman"

N-351 Cylinder Head

Race Master Valves & Severe Duty® Valves

- ▶ Chrome Stems and Hard Tips
- ▶ Swirl Polished and Fully Machined



Part No.	Type	Head Diameter	Stem Diameter	Installed Height	O/A Length	Tip Length	Underhead Angle/Radius	Margin	Seat Width	Top of Head	Wgt/ Grams
RACE MASTER VALVES											
11321-8	Exh.	1.600	.3415	Stock	5.165	.290	15° x 1/2"	.090	.100	9° Dish	112
11316-8	Int.	2.020	.3415	Stock	5.140	.290	12° x 3/8"	.065	.080	7° Dish	127
SEVERE DUTY® VALVES											
11865-8	Exh.	1.600	.3415	Stock	5.121	.250	15° x 1/2"	.070	.100	9° Dish	105
11751-8	Exh.	1.600	.3415	Stock	5.165	.290	15° x 1/2"	.090	.100	9° Dish	110
11544-8	Int.	2.020	.3415	Stock	5.140	.290	10° x 3/8"	.065	.080	5° Dish	125

Need a different length? Head diameter not listed? Prefer a BeadLoc® groove?
See pages 42 & 43 for Gen II blanks to construct a valve to your exact specifications.

Ford 2300 "Esslinger" Race Master Valves



Part No.	Type	Head Diameter	Stem Diameter	Installed Height	O/A Length	Tip Length	Underhead Angle/Radius	Margin	Seat Width	Top of Head	Wgt/ Grams
SEMI-FINISHED VALVES FOR "ESSLINGER" HEADS											
11791-4	Exh.	1.590	.3415	*	4.800	*	15° x 1/2"	.060	.100	9° Dish	105
11790-4	Int.	1.890	.3415	*	4.800	*	10° x 3/8"	.050	.080	5° Dish	110
FINISHED VALVES FOR "ESSLINGER" FLAT TAPPET APPLICATIONS											
11793-4	Exh.	1.590	.3415	Stock	4.800	.550	15° x 1/2"	.060	.100	9° Dish	104
11792-4	Int.	1.890	.3415	Stock	4.800	.550	10° x 3/8"	.050	.080	5° Dish	109
FINISHED VALVES FOR "ESSLINGER" ROLLER TAPPET APPLICATIONS											
11795-4	Exh.	1.590	.3415	Stock	4.800	.400	15° x 1/2"	.060	.100	9° Dish	104
11794-4	Int.	1.890	.3415	Stock	4.800	.400	10° x 3/8"	.050	.080	5° Dish	109

Valves 11790 and 11791 have hard tips but no grooves. Use P/N 04008 to order custom grooved valves.

Ford 429 - 460 Race Master Valves

- ▶ XH-426 Stainless Exhaust Material
- ▶ NK-842 Stainless Intake Material
- ▶ Chrome Stems and Hard Tips
- ▶ Swirl Polished and Fully Machined



Part No.	Type	Head Diameter	Stem Diameter	Installed Height	O / A Length	Tip Length	Underhead Angle / Radius	Margin	Seat Width	Top of Head	Wgt / Grams
11875-8	Exh.	1.760	.3415	Stock	5.042	.250	12° x 3/8"	.060	.100	7° Dish	110
11872-8	Int.	2.190	.3415	Stock	5.244	.250	10° x 3/8"	.050	.080	5° Dish	129
11874-8	Int.	2.250	.3415	Stock	5.244	.250	10° x 3/8"	.050	.080	5° Dish	130
BLUE THUNDER HEADS											
11829-8	Exh.	1.880	.3415	Stock	5.070	.250	25° x 3/8"	.090	.100	20° Dish	118
11899-8	Exh.	1.880	.3415	.100 Longer	5.170	.250	25° x 3/8"	.090	.100	20° Dish	120
11874-8	Int.	2.250	.3415	Stock	5.244	.250	10° x 3/8"	.050	.080	5° Dish	130

Ford 429 - 460 Severe Duty® Valves

- ▶ XH-428 Stainless Exhaust Material
- ▶ NK-844 Stainless Intake Material
- ▶ Chrome Stems and Hard Tips
- ▶ Swirl Polished and Fully Machined



Part No.	Type	Head Diameter	Stem Diameter	Installed Height	O / A Length	Tip Length	Underhead Angle / Radius	Margin	Seat Width	Top of Head	Wgt / Grams
11529-8	Exh.	1.760	.3415	Stock	5.067	.250	12° x 3/8"	.085	.085	7° Dish	113
11801-8	Exh.	1.760	.3415	.100 Longer	5.167	.250	12° x 3/8"	.085	.085	7° Dish	116
11800-8	Int.	2.190	.3415	Stock	5.244	.250	12° x 3/8"	.050	.080	7° Dish	139
11822-8	Int.	2.190	.3415	.100 Longer	5.344	.250	12° x 3/8"	.050	.080	7° Dish	140
11802-8	Int.	2.250	.3415	Stock	5.244	.250	12° x 3/8"	.050	.100	7° Dish	139
11850-8	Int.	2.250	.3415	.100 Longer	5.344	.250	12° x 3/8"	.050	.100	7° Dish	142

The size of the Super Cobra Jet valves are 2.245" Int. (30° seat) and 1.750" Exh. Other 429 - 460 cylinder heads have smaller valve diameters. Our valves can be easily cut or the seats enlarged.

Need a different length? Head diameter not listed? Prefer a BeadLoc® groove?
See pages 42 & 43 for Gen II blanks to construct a valve to your exact specifications.

STAINLESS VALVES

VALVES

Ford 429 - 460

Aluminum Aftermarket Heads Race Master & Severe Duty® Valves

- ▶ XH-426 Stainless Exhaust Material
- ▶ NK-844 Stainless Intake Material
- ▶ Chrome Stems and Hard Tips
- ▶ Swirl Polished and Fully Machined



Part No.	Type	Head Diameter	Stem Diameter	Installed Height	O / A Length	Tip Length	Underhead Angle / Radius	Margin	Seat Width	Top of Head	Wgt / Grams
RACE MASTER VALVES											
11591-8	Exh.	1.880	.3415	Stock	5.655	.260	25° x 3/8"	.075	.100	20° Dish	129
SEVERE DUTY® VALVES											
11586-8	Int.	2.250	.3415	Stock	5.725	.260	10° x 13/32"	.065	.075	5° Dish	153
11588-8	Int.	2.300	.3415	Stock	5.725	.260	10° x 13/32"	.065	.075	5° Dish	166
11590-8	Int.	2.400	.3415	Stock	5.725	.260	10° x 13/32"	.065	.075	5° Dish	170

(11588 = M-6507-A460; 11586 = M-6507-B460; 11591 = M-6505-A460; 11590 = M-6507-E460)

Ford 427

Medium, Hi Riser, Tunnel Port Severe Duty® Solid Stem Valves

- ▶ XH-428 Stainless Exhaust Material
- ▶ NK-844 Stainless Intake Material
- ▶ Chrome Stems and Hard Tips
- ▶ Swirl Polished and Fully Machined



Part No.	Type	Head Diameter	Stem Diameter	Installed Height	O / A Length	Tip Length	Underhead Angle / Radius	Margin	Seat Width	Top of Head	Wgt / Grams
11825-8	Exh.	1.750	.3705	Stock	5.426	.320	20° x 3/8"	.060	.100	15° Dish	124
11884-8	Int.	2.190	.3715	Stock	5.446	.320	23° x 5/16"	.070	.120	20° Dish	143
11804-8	Int.	2.250	.3715	Stock	5.454	.320	23° x 5/16"	.065	.090	20° Dish	145

The above valves can be cut down to 1.656" for the 428 exhaust and 2.090" for the 428 intake. The lengths of the 427 and 428 valves are the same. Valves 11804 and 11884 have a 30° seat.

Ford Boss 429

Race Master Valves

- ▶ XH-426 Stainless Exhaust Material
- ▶ NK-842 Stainless Intake Material
- ▶ Chrome Stems and Hard Tips
- ▶ Swirl Polished and Fully Machined



Part No.	Type	Head Diameter	Stem Diameter	Installed Height	O / A Length	Tip Length	Underhead Angle / Radius	Margin	Seat Width	Top of Head	Wgt / Grams
11787-8	Exh.	1.900	.3715	Stock	5.650	.350	15° x 1/2"	.080	.100	9° Dish	122
11786-8*	Int.	2.280	.3715	Stock	5.625	.350	12° x 3/8"	.060	.100	7° Dish	141
11788-8*	Int.	2.400	.3715	Stock	5.570	.350	12° x 3/8"	.060	.100	7° Dish	143

* P/N 11786-8 & P/N 11788-8 have a 30° seat

5.570" is the length of the NASCAR intake valve. It is short because it is sunk in the head. If you do not wish to sink the valve, order a GEN II intake at your desired length.

Volkswagen Rabbit

Race Master Valves

- ▶ XH-426 Stainless Exhaust Material
- ▶ NK-842 Stainless Intake Material
- ▶ Chrome Stems, Swirl Polished and Fully Machined
- ▶ Special Hard Tips and Hardened Keeper Grooves



Part No.	Type	Head Diameter	Stem Diameter	Installed Height	O / A Length	Tip Length	Underhead Angle / Radius	Margin	Seat Width	Top of Head	Wgt / Grams
11657-4	Exh.	34.0mm	.3130	Stock	3.976	.130	15° x 3/8"	.075	.075	10° Dish	63
11656-4	Int.	40.5mm	.3130	Stock	3.976	.130	10° x 11/32"	.075	.075	5° Dish	76

Volkswagen 1200 - 1600

Race Master Valves

- ▶ XH-426 Stainless Exhaust Material
- ▶ NK-842 Stainless Intake Material
- ▶ Available with factory triple or Chevy LS single radius keeper grooves. See pages 72 and 73 for compatible valve springs and retainers when using the Chevy LS keeper groove.
- ▶ Chrome Stems, Swirl Polished and Fully Machined
- ▶ Special Hard Tips and Hardened Keeper Grooves



Triple Groove Part No.	Single Groove Part No.	Type	Head Diameter	Stem Diameter	Installed Height	O / A Length	Tip Length	Underhead Angle / Radius	Margin	Seat Width	Top of Head	Wgt / Grams
11649-4	11649B-4	Exh.	32.0mm	.3130	Stock	4.405	.170	15° x 3/8"	.070	.090	10° Dish	65
11651-4	11651B-4	Exh.	33.0mm	.3130	Stock	4.405	.170	15° x 3/8"	.070	.090	10° Dish	67
11653-4	11653B-4	Exh.	35.5mm	.3130	Stock	4.405	.170	15° x 3/8"	.070	.090	10° Dish	69
11655-4	11655B-4	Exh.	37.5mm	.3130	Stock	4.405	.170	15° x 3/8"	.070	.090	10° Dish	73
11650-4	11650B-4	Int.	40.0mm	.3130	Stock	4.405	.170	10° x 11/32"	.070	.090	6° Dish	79
11652-4	11652B-4	Int.	42.0mm	.3130	Stock	4.405	.170	10° x 11/32"	.070	.090	6° Dish	79
11654-4	11654B-4	Int.	43.7mm	.3130	Stock	4.405	.170	10° x 11/32"	.070	.090	6° Dish	83

Volkswagen Type IV

Race Master Valves

- ▶ XH-426 Stainless Exhaust Material
- ▶ NK-842 Stainless Intake Material
- ▶ Available with factory triple or Chevy LS single radius keeper grooves. See pages 72 and 73 for compatible valve springs and retainers when using the Chevy LS keeper groove.
- ▶ Chrome Stems, Swirl Polished and Fully Machined
- ▶ Special Hard Tips and Hardened Keeper Grooves



Triple Groove Part No.	Single Groove Part No.	Type	Head Diameter	Stem Diameter	Installed Height	O / A Length	Tip Length	Underhead Angle / Radius	Margin	Seat Width	Top of Head	Wgt / Grams
11629-4*	-----	Exh.	36mm	.3130	Stock	4.606	.170	15° x 1/2"	.060	.075	9° Dish	77
11659-4	11659B-4	Exh.	38mm	.3130	Stock	4.606	.170	15° x 1/2"	.060	.075	9° Dish	78
11663-4	11663B-4	Exh.	40mm	.3130	Stock	4.606	.170	15° x 1/2"	.060	.100	9° Dish	88
11628-4*	-----	Int.	42mm	.3130	Stock	4.606	.170	10° x 3/8"	.060	.075	5° Dish	84
11602-4	-----	Int.	44mm	.3130	Stock	4.606	.170	10° x 3/8"	.060	.075	5° Dish	89
11604-4	-----	Int.	46mm	.3130	Stock	4.606	.170	10° x 3/8"	.060	.075	5° Dish	94
11658-4	11658B-4	Int.	48mm	.3130	Stock	4.606	.170	10° x 3/8"	.060	.075	5° Dish	100
11662-4	11662B-4	Int.	50mm	.3130	Stock	4.606	.170	10° x 3/8"	.060	.075	5° Dish	101

* Replacement valves for the Porsche 914 2.0L

CUSTOM STAINLESS VALVES

VALVES

Gen II Valve Blanks

Extreme Duty & Severe Duty® Series

- ▶ Hard Tips and Hardened Grooves
- ▶ No Need for Inserted Tips or Wear Caps

The procedure for ordering a custom valve is as simple as 1-2-3!

1. Select the blank appropriate for your finished piece based first on stem diameter.
2. Give us your final head diameter along with the seat and margin widths.
3. Specify the length of the valve you want, along with groove type and location.

* Part numbers with asterisks can be reduced 1.500" or 38mm, except P/N's 11223/11277 which can be reduced 1.800". All others .800" or 20.32mm.



All Gen II custom stainless valve part numbers are priced to include all machining to render a finished valve provided that no more than .250" of material needs to be removed from the head diameter. If more than .250" of material is to be removed from the head diameter, then an additional machining charge P/N 04007 must be added to the price of the valve.

Part No.	Type	Maximum Head Diameter	Stem Diameter	Maximum Length	Underhead Angle / Radius	Margin	Seat Width	Top of Head	Material
XTREMEALLOY GEN II CUSTOM EXHAUST VALVES									
11225-8*	Exh.	41.3mm / 1.625	.3415	142.2mm / 5.600	15° x 1/2"	.080	.100	9° Dish	XtremeAlloy
11223-8*	Exh.	52.3mm / 2.060	.3415	170.2mm / 6.700	15° x 1/2"	.080	.100	9° Dish	XtremeAlloy
11277-8*	Exh.	52.3mm / 2.060	.3415	170.2mm / 6.700	18° x 1/2"	.080	.100	Flat Face	XtremeAlloy
11275-8*	Exh.	42.0mm / 1.654	8.0mm / .3136	146.0mm / 5.750	25° x 7/16"	.065	.100	18° Dish	XtremeAlloy
11285-8*	Exh.	41.9mm / 1.650	.3110	154.9mm / 6.100	15° x 1/2"	.080	.100	9° Dish	XtremeAlloy
11257-8	Exh.	44.5mm / 1.750	.3095	137.2mm / 5.400	25° x 3/8"	.060	.100	20° Dish	XtremeAlloy
11281-8*	Exh.	38.0mm / 1.496	6.96mm / .2740	127.0mm / 5.000	15° x 1/2"	.080	.100	9° Dish	XtremeAlloy
11265-8*	Exh.	39.0mm / 1.535	5.96mm / .2345	121.9mm / 4.800	25° x 11/32"	.080	.100	20° Dish	XtremeAlloy
11283-8*	Exh.	33.0mm / 1.299	5.46mm / .2150	121.0mm / 4.764	25° x 11/32"	.065	.080	Flat Face	XtremeAlloy
SEVERE DUTY® GEN II CUSTOM VALVES									
11251-8	Exh.	49.3mm / 1.940	.3715	143.5mm / 5.650	12° x 3/8"	.085	.100	7° Dish	XH-428
11252-8*	Int.	58.4mm / 2.300	.3720	142.2mm / 5.600	Pro Flo: 12° x 7/16"	.065	.080	7° Dish	NK-844
11252H-8*	Int.	58.4mm / 2.300	.3720 Hollow Stem	142.2mm / 5.600	Pro Flo: 12° x 7/16"	.065	.080	7° Dish	NK-844
Pro Flo start is 1.600" from the top of the head.									
11245-8	Exh.	41.3mm / 1.625	.3415	143.3mm / 5.640	15° x 1/2"	.090	.100	9° Dish	XH-428
11255-8	Exh.	41.3mm / 1.625	.3415	143.3mm / 5.640	30° x 1/2"	.070	.100	25° Dish	XH-428
11253-8	Exh.	49.3mm / 1.940	.3415	143.5mm / 5.650	12° x 3/8"	.075	.080	7° Dish	XH-428
11221-8	Exh.	50.8mm / 2.000	.3415	170.2mm / 6.700	25° x 3/8"	.080	.100	20° Dish	XH-428
11219-8	Exh.	52.3mm / 2.060	.3415	170.2mm / 6.700	15° x 1/2"	.080	.100	9° Dish	XH-428
11256-8*	Int.	52.8mm / 2.080	.3415	143.3mm / 5.640	10° x 3/8"	.065	.080	5° Dish	NK-844
11254-8*	Int.	54.6mm / 2.150	.3415	143.3mm / 5.640	12° x 3/8"	.065	.080	7° Dish	NK-844
11254H-8*	Int.	54.6mm / 2.150	.3415 Hollow Stem	143.3mm / 5.640	12° x 3/8"	.065	.080	7° Dish	NK-844
11242-8*	Int.	54.6mm / 2.150	.3415	143.6mm / 5.655	Pro Flo: 12° x 3/8"	.065	.080	7° Dish	NK-844
Pro Flo start is 1.600" from the top of the head.									
11258-8*	Int.	61.6mm / 2.425	.3415	144.8mm / 5.700	12° x 3/8"	.065	.080	7° Dish	NK-844
11220-8*	Int.	63.5mm / 2.500	.3415	172.7mm / 6.800	10° x 3/8"	.050	.080	5° Dish	NK-844
11222-8*	Int.	61.6mm / 2.425	.3415	170.2mm / 6.700	20° x 3/8"	.050	.080	15° Dish	NK-844
11279-8*	Exh.	42.0mm / 1.654	8.0mm / .3136	142.2mm / 5.600	25° x 7/16"	.065	.100	18° Dish	XH-428
11274-8*	Int.	57.2mm / 2.250	8.0mm / .3133	142.2mm / 5.600	Pro Flo: 12° x 3/8"	.060	.095	7° Dish	NK-844
11274H-8*	Int.	57.2mm / 2.250	8.0mm / .3133 Hollow Stem	142.2mm / 5.600	Pro Flo: 12° x 3/8"	.060	.095	7° Dish	NK-844
Pro Flo start is 1.300" from the top of the head.									
11227-8	Exh.	41.3mm / 1.625	.3110	146.1mm / 5.750	15° x 1/2"	.080	.100	9° Dish	XH-428
11263-8	Exh.	49.3mm / 1.940	.3110	154.9mm / 6.100	12° x 3/8"	.085	.100	7° Dish	XH-428
11224-8*	Int.	55.9mm / 2.200	.3110	146.1mm / 5.750	12° x 3/8"	.050	.080	7° Dish	NK-844
11224H-8*	Int.	55.9mm / 2.200	.3110 Hollow Stem	146.1mm / 5.750	12° x 3/8"	.050	.080	7° Dish	NK-844
11264-8*	Int.	61.0mm / 2.400	.3110	160.0mm / 6.300	10° x 3/8"	.065	.080	5° Dish	NK-844
11264H-8*	Int.	61.0mm / 2.400	.3110 Hollow Stem	160.0mm / 6.300	10° x 3/8"	.065	.080	5° Dish	NK-844
11229-8	Exh.	41.3mm / 1.625	6.96mm / .2740	142.2mm / 5.600	15° x 1/2"	.080	.100	9° Dish	XH-428
11226-8*	Int.	55.9mm / 2.200	6.96mm / .2740	142.2mm / 5.600	10° x 3/8"	.050	.080	5° Dish	NK-844

Part numbers 11274 and 11274H have a 50° seat angle, all others are 45°.

CUSTOM STAINLESS VALVES

Gen II Valve Blanks

Race Series

- ▶ Hard Tips and Hardened Grooves
- ▶ No Need for Inserted Tips or Wear Caps

The procedure for ordering a custom valve is as simple as 1-2-3 !

1. Select the blank appropriate for your finished piece based first on stem diameter.
2. Give us your final head diameter along with the seat and margin widths.
3. Specify the length of the valve you want, along with groove type and location.

* Part numbers with asterisks can be reduced 1.500" or 38mm. All others .800" or 20.32mm.



All Gen II custom stainless valve part numbers are priced to include all machining to render a finished valve provided that no more than .250" of material needs to be removed from the head diameter. If more than .250" of material is to be removed from the head diameter, then an additional machining charge P/N 04007 must be added to the price of the valve.

Part No.	Type	Maximum Head Diameter	Stem Diameter	Maximum Length	Underhead Angle / Radius	Margin	Seat Width	Top of Head	Material
11215-8	Exh.	49.3mm / 1.940	.3715	143.5mm / 5.650	15° x 1/2"	.080	.100	9° Dish	XH-426
11214-8	Int.	61.6mm / 2.425	.3715	143.5mm / 5.650	12° x 3/8"	.050	.080	7° Dish	NK-842
11203-8	Exh.	41.3mm / 1.625	.3415	139.7mm / 5.500	15° x 1/2"	.090	.100	9° Dish	XH-426
11217-8	Exh.	41.9mm / 1.650	.3415	143.3mm / 5.640	Pro Flo: 15° x 1/2"	.090	.100	9° Dish	XH-426
Pro Flo start is 1.600" from the top of the head.									
11243-8	Exh.	48.3mm / 1.900	.3415	144.8mm / 5.700	25° x 3/8"	.080	.100	20° Dish	XH-426
11201-8	Exh.	49.3mm / 1.940	.3415	162.9mm / 6.415	25° x 3/8"	.080	.100	20° Dish	XH-426
11241-8	Exh.	49.3mm / 1.940	.3415	152.4mm / 6.000	10° x 3/8"	.075	.100	5° Dish	XH-426
11218-8	Int.	54.0mm / 2.125	.3415	140.7mm / 5.540	12° x 3/8"	.065	.080	7° Dish	NK-842
11216-8	Int.	54.6mm / 2.150	.3415	143.6mm / 5.655	Pro Flo: 12° x 3/8"	.065	.080	7° Dish	NK-842
Pro Flo start is 1.600" from the top of the head.									
11200-8	Int.	60.3mm / 2.375	.3415	144.8mm / 5.700	10° x 3/8"	.050	.080	5° Dish	NK-842
11244-8	Int.	61.6mm / 2.425	.3415	167.6mm / 6.600	10° x 3/8"	.050	.080	5° Dish	NK-842
11211-4	Exh.	38.5mm / 1.516	8.0mm / .3130	114.3mm / 4.500	15° x 3/8"	.060	.090	10° Dish	XH-426
11205-4	Exh.	40.0mm / 1.575	8.0mm / .3130	127.0mm / 5.000	15° x 1/2"	.080	.100	9° Dish	XH-426
11210-4	Int.	48.5mm / 1.909	8.0mm / .3130	114.3mm / 4.500	10° x 11/32"	.060	.080	5° Dish	NK-842
11204-4	Int.	52.0mm / 2.047	8.0mm / .3130	127.0mm / 5.000	10° x 3/8"	.050	.080	5° Dish	NK-842
11269-8*	Exh.	42.0mm / 1.654	8.0mm / .3136	142.2mm / 5.600	25° x 7/16"	.065	.100	18° Dish	XH-426
11270-8*	Int.	56.5mm / 2.225	8.0mm / .3133	142.2mm / 5.600	Pro Flo: 12° x 3/8"	.060	.095	7° Dish	NK-842
11270H-8*	Int.	56.5mm / 2.225	8.0mm / .3133 Hollow Stem	142.2mm / 5.600	Pro Flo: 12° x 3/8"	.060	.095	7° Dish	NK-842
Pro Flo start is 1.300" from the top of the head.									
11271-8	Exh.	42.6mm / 1.675	.3125	134.6mm / 5.300	25° x 1/2"	.080	.100	20° Dish	XH-426
11272-8	Int.	56.5mm / 2.225	.3125	134.6mm / 5.300	Pro Flo: 10° x 5/16"	.065	.095	5° Dish	NK-842
11272H-8	Int.	56.5mm / 2.225	.3125 Hollow Stem	134.6mm / 5.300	Pro Flo: 10° x 5/16"	.065	.095	5° Dish	NK-842
Pro Flo start is 1.300" from the top of the head.									
11207-8	Exh.	41.3mm / 1.625	.3110	144.8mm / 5.700	15° x 1/2"	.080	.100	9° Dish	XH-426
11261-8	Exh.	41.3mm / 1.625	.3110	162.6mm / 6.400	18° x 1/2"	.080	.100	12° Dish	XH-426
11206-8	Int.	55.9mm / 2.200	.3110	144.8mm / 5.700	10° x 3/8"	.050	.080	5° Dish	NK-842
11262-8	Int.	53.3mm / 2.100	.3110	162.6mm / 6.400	12° x 3/8"	.050	.080	7° Dish	NK-842
11249-8	Exh.	53.3mm / 2.100	.3100	137.2mm / 5.400	22° x 1/4"	.050	.100	17° Dish	XH-426
11248-8*	Int.	58.4mm / 2.300	.3100	149.9mm / 5.900	24° x 3/4"	.060	.080	19° Dish	NK-842
11247-8	Exh.	37.0mm / 1.457	6.96mm / .2740	121.9mm / 4.800	15° x 1/2"	.080	.100	9° Dish	XH-426
11246-8	Int.	48.0mm / 1.890	6.96mm / .2740	121.9mm / 4.800	10° x 3/8"	.050	.080	5° Dish	NK-842
11267-8	Exh.	41.9mm / 1.650	7.0mm / .2755	119.4mm / 4.700	30° x 1/2"	.060	.100	24° Dish	XH-426
11250-8*	Int.	48.0mm / 1.890	7.0mm / .2750	137.9mm / 5.430	10° x 3/8"	.065	.080	5° Dish	NK-842
11268-8	Int.	50.8mm / 2.000	7.0mm / .2755	116.8mm / 4.600	28° x 7/16"	.050	.100	22° Dish	NK-842
11213-8	Exh.	33.0mm / 1.299	6.0mm / .2362	113.5mm / 4.469	25° x 11/32"	.065	.080	20° Dish	XH-426
11212-8	Int.	39.0mm / 1.535	6.0mm / .2362	113.5mm / 4.469	Pro Flo: 22° x 5/16"	.065	.080	17° Dish	NK-842
11266-8*	Int.	35.0mm / 1.378	5.98mm / .2355	121.9mm / 4.800	12° x 5/16"	.065	.100	7° Dish	NK-842
11276-4	Int.	40.0mm / 1.575	5.97mm / .2350	113.0mm / 4.449	25° x 11/32"	.065	.100	Flat Face	NK-842
11209-8	Exh.	32.0mm / 1.260	5.46mm / .2150	121.0mm / 4.764	25° x 11/32"	.065	.080	Flat Face	XH-426
11208-8	Int.	37.0mm / 1.457	5.48mm / .2157	121.0mm / 4.764	Pro Flo: 22° x 5/16"	.065	.080	Flat Face	NK-842

Gen II CUSTOM VALVE FORM

PLEASE SEE GEN II CUSTOM VALVE SPECIFICATIONS PAGES 40 & 41

A WEAR CAP IS NOT NECESSARY WITH GEN II*

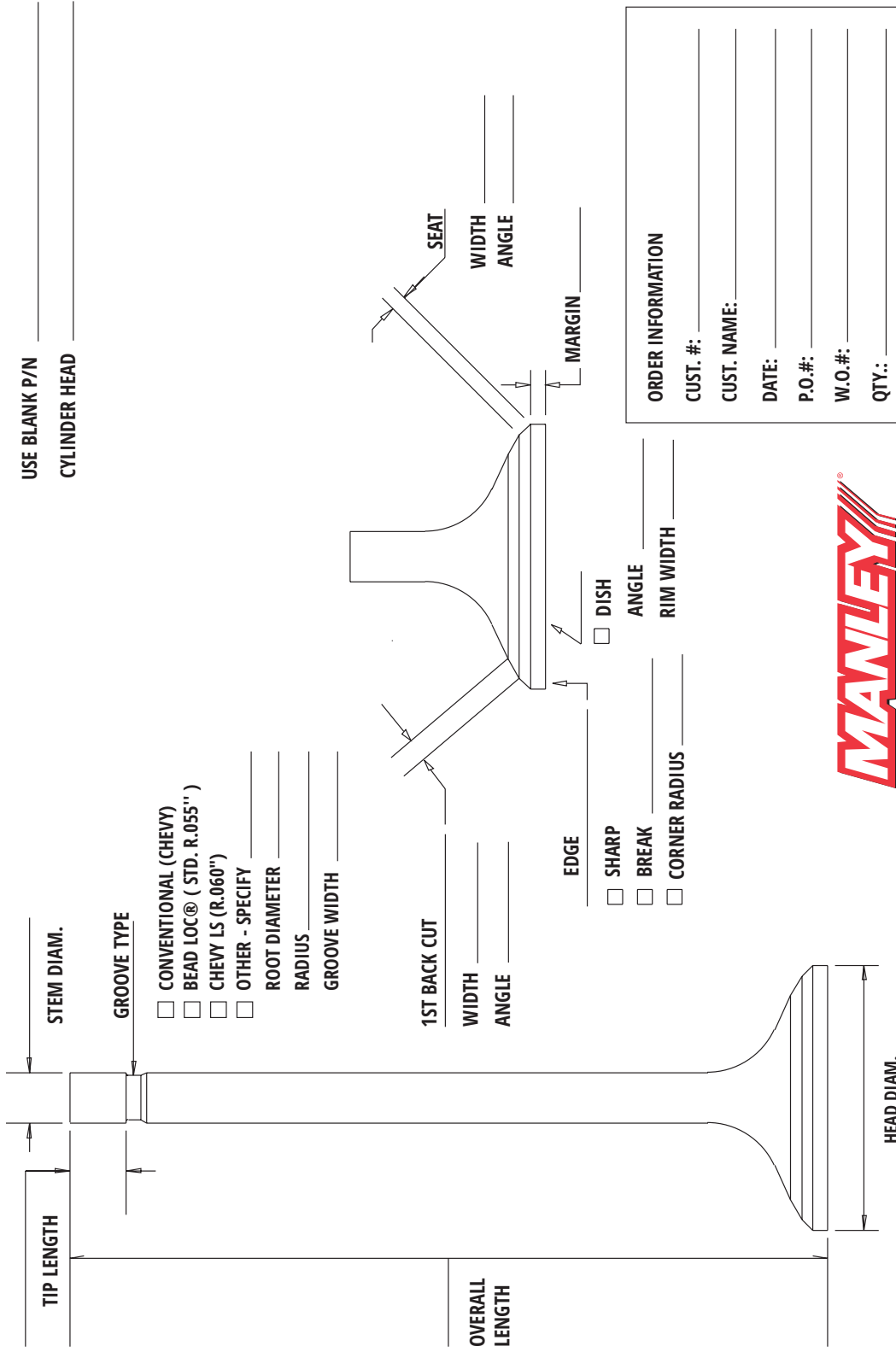

PLEASE FILL IN ALL DIMENSIONS AND ORDER INFORMATION

USE BLANK P/N _____
CYLINDER HEAD _____

ORDER INFORMATION

CUST. #: _____
CUST. NAME: _____
DATE: _____
P.O.#: _____
W.O.#: _____
QTY.: _____
DUE DATE: _____
SHIP VIA: _____



PHONE: 732-905-3366
FAX: 732-905-3010
EMAIL: sales@manleyperformance.com

* Provided that the overall length is within the minimum length parameter of the Gen II blank that is machined.

By signing this form I accept the goods are nonreturnable for credit and that Manley takes no responsibility for incorrectly ordered items.

CUSTOMER NAME _____

CUSTOMER SIGNATURE _____ DATE ____/____/____

Titanium CUSTOM VALVE FORM

WITH HARD TIP P/N _____

WITHOUT HARD TIP _____

TIP LENGTH _____

STEM DIAM. _____

GROOVE TYPE _____

OVERALL LENGTH _____

MOLY LENGTH _____

MOLY START _____

HEAD DIAM. _____

USE BLANK P/N _____

CYLINDER HEAD _____

CONVENTIONAL (CHEVY)

BEAD LOC® (STD. R.055")

CHEVY LS (R.060")

OTHER - SPECIFY _____

ROOT DIAMETER _____

RADIUS _____

GROOVE WIDTH _____

1ST BACK CUT

WIDTH _____

ANGLE _____

2ND BACK CUT

WIDTH _____

ANGLE _____

EDGE _____

SHARP

BREAK

CORNER RADIUS _____

STRAIGHT LENGTH _____

PROFILE

TAPER ANGLE _____

UNDERCUT LEN. _____

BLEND RADIUS _____

UNDERCUT DIAM. _____

PHONE: 732-905-3366

FAX: 732-905-3010

EMAIL: sales@manleyperformance.com



CRN COATING OPTIONS (CALICO)

SEAT FACE

TIP

FULL VALVE (CRN SLICK STEM)

BACKANGLE & RADIUS

SEAT

WIDTH _____

ANGLE _____

MARGIN _____

DISH

ANGLE _____

RIM WIDTH _____

BLEND RADIUS & WIDTH _____

CENTER RADIUS _____

ORDER INFORMATION

CUST. #: _____

CUST. NAME: _____

DATE: _____

P.O.#: _____

W.O.#: _____

QTY.: _____

DUE DATE: _____

SHIP VIA: _____

By signing this form I accept the goods are nonreturnable for credit and that Manley takes no responsibility for incorrectly ordered items.

CUSTOMER NAME

CUSTOMER SIGNATURE _____ DATE ____/____/____

TITANIUM VALVES

VALVES

Small Block GM, Ford & Chrysler

Titanium Exhaust Valves

- ▶ All valves have inserted hard tips
- ▶ "HT" suffix indicates high temperature material
- ▶ Available with conventional square or Manley's Bead Loc[®] single radius keeper grooves



Square Groove Part No.	Bead Loc [®] Groove Part No.	Head Diameter	Stem Diameter	Installed Height	O / A Length	Tip Length	Underhead Angle/Radius	Margin	Seat Width/Angle	Wgt / Grams
11401T-8	11401TB-8	1.600	.3415	.100 Longer	5.060	.290	15° x 1/2"	.100	.100/45°	73
11403T-8	11403TB-8	1.600	.3415	.200 Longer	5.160	.290	15° x 1/2"	.100	.100/45°	74
11405T-8	11405TB-8	1.600	.3415	.300 Longer	5.260	.290	15° x 1/2"	.100	.100/45°	75
11407T-8	11407TB-8	1.600	.3415	.400 Longer	5.360	.290	15° x 1/2"	.100	.100/45°	76
11409T-8	11409TB-8	1.600	.3415	.500 Longer	5.460	.290	15° x 1/2"	.100	.100/45°	77
11451T-8	11451TB-8	1.600	.3415	.600 Longer	5.560	.290	15° x 1/2"	.100	.100/45°	78
11463T-8	11463TB-8	1.600	.3415	Stock	4.960	.290	20° x 7/16"	.100	.100/45°	74
11425T-8	11425TB-8	1.600	.3415	.100 Longer	5.060	.290	20° x 7/16"	.100	.100/45°	75
-----	11421TB-8	1.600	.3110	.200 Longer	5.140	.290	20° x 7/16"	.080	.100/45°	68
11467HT-8*	11467HTB-8*	1.600	.3415	.200 Longer	5.140	.290	20° x 7/16"	.080	.085/45°	73
11427T-8	11427TB-8	1.600	.3415	.200 Longer	5.140	.290	20° x 7/16"	.080	.100/45°	74
11427HT-8	11427HTB-8	1.600	.3415	.200 Longer	5.140	.290	20° x 7/16"	.080	.100/45°	74
11429T-8	11429TB-8	1.600	.3415	.300 Longer	5.260	.290	20° x 7/16"	.100	.100/45°	77
11431T-8	11431TB-8	1.600	.3415	.400 Longer	5.360	.290	20° x 7/16"	.100	.100/45°	78
11433T-8	11433TB-8	1.600	.3415	.500 Longer	5.460	.290	20° x 7/16"	.100	.100/45°	79
11471HT-8	11471HTB-8	1.600	.3415	.600 Longer	5.560	.290	20° x 7/16"	.100	.100/45°	80
-----	11487TB-8	1.600	.3415	.800 Longer	5.740	.290	20° x 7/16"	.080	.100/45°	82
11469HT-8	11469HTB-8	1.600	.3415	.600 Longer	5.560	.290	25° x 3/4"	.100	.100 /45°	83
11411T-8	11411TB-8	1.625	.3415	.100 Longer	5.060	.290	15° x 1/2"	.100	.100/45°	74
11413T-8	11413TB-8	1.625	.3415	.200 Longer	5.160	.290	15° x 1/2"	.100	.100/45°	75
11417T-8	11417TB-8	1.625	.3415	.400 Longer	5.360	.290	15° x 1/2"	.100	.100/45°	77
11419T-8	11419TB-8	1.625	.3415	.500 Longer	5.460	.290	15° x 1/2"	.100	.100/45°	78
11447T-8	11447TB-8	1.625	.3415	.600 Longer	5.560	.290	15° x 1/2"	.100	.100/45°	79
11435T-8	11435TB-8	1.625	.3415	.100 Longer	5.060	.290	20° x 7/16"	.100	.100/45°	75
11437T-8	11437TB-8	1.625	.3415	.200 Longer	5.140	.290	20° x 7/16"	.080	.100/45°	74
11439T-8	11439TB-8	1.625	.3415	.300 Longer	5.260	.290	20° x 7/16"	.100	.100/45°	77
11441T-8	11441TB-8	1.625	.3415	.400 Longer	5.360	.290	20° x 7/16"	.100	.100/45°	78
11443T-8	11443TB-8	1.625	.3415	.500 Longer	5.460	.290	20° x 7/16"	.100	.100/45°	79
11453T-8	11453TB-8	1.625	.3415	.600 Longer	5.560	.290	20° x 7/16"	.100	.100/45°	80
11453HT-8	11453HTB-8	1.625	.3415	.600 Longer	5.560	.290	20° x 7/16"	.100	.100/45°	80
-----	11475HTB-8	1.625	.3415	.700 Longer	5.660	.290	20° x 7/16"	.100	.100/45°	81
-----	11489TB-8	1.625	.3415	.800 Longer	5.740	.290	20° x 7/16"	.080	.100/45°	83
11455HT-8	11455HTB-8	1.625	.3415	.500 Longer	5.460	.290	25° x 3/4"	.100	.100/45°	85
11457T-8	11457TB-8	1.625	.3415	.600 Longer	5.560	.290	25° x 3/4"	.100	.100/45°	86
11457HT-8	11457HTB-8	1.625	.3415	.600 Longer	5.560	.290	25° x 3/4"	.100	.100/45°	86
11473T-8	11473TB-8	1.625	.3415	.700 Longer	5.660	.290	25° x 3/4"	.100	.100/45°	87
-----	11477TB-8	1.625	.3415	.700 Longer	5.640	.290	25° x 1/2"	.080	.100/55°	85
11445T-8	11445TB-8	1.650	.3415	.500 Longer	5.460	.290	20° x 7/16"	.100	.100/45°	81

*Valve P/N's 11467HT and 11467HTB have a back cut of .055" x 30°.

Small Block GM, Ford & Chrysler Up To 2.150" Head Diameters

Titanium Intake Valves

2.180" and 2.200" head diameter offerings continued on next page

- ▶ All valves have inserted hard tips
- ▶ "HT" suffix indicates higher hardness material
- ▶ Available with conventional square or Manley's Bead Loc® single radius keeper grooves
- ▶ "C" suffix indicates CrN seat coating (See page 53 for more details)



Square Groove Part No.	Bead Loc® Groove Part No.	Head Diameter	Stem Diameter	Installed Height	O / A Length	Tip Length	Underhead Angle/Radius	Margin	Seat Width/Angle	Back Cut Width/Angle	Wgt / Grams
11948T-8	11948TB-8	2.020	.3415	.200 Longer	5.140	.290	10° x 3/8"	.080	.100/45°	-----	86
11452T-8	11452TB-8	2.055	.3415	Stock	4.940	.290	10° x 3/8"	.080	.100/45°	-----	85
11474T-8	11474TB-8	2.055	.3415	.100 Longer	5.040	.290	10° x 3/8"	.080	.100/45°	-----	86
11950T-8	11950TB-8	2.055	.3415	.200 Longer	5.140	.290	10° x 3/8"	.080	.100/45°	-----	87
11454T-8	11454TB-8	2.080	.3415	Stock	4.940	.290	10° x 3/8"	.080	.100/45°	-----	86
-----	11440HTBC-8	2.080	.3110	.100 Longer	5.040	.290	10° x 3/8"	.080	.060/45°	.080/30°	80
11400T-8	11400TB-8	2.080	.3415	.100 Longer	5.040	.290	10° x 3/8"	.080	.100/45°	-----	87
-----	11400HTBC-8	2.080	.3415	.100 Longer	5.040	.290	10° x 3/8"	.080	.060/45°	.080/30°	87
-----	11472HTB-8	2.080	.3110	.200 Longer	5.140	.290	10° x 3/8"	.080	.100/45°	-----	81
-----	11472HTBC-8	2.080	.3110	.200 Longer	5.140	.290	10° x 3/8"	.080	.060/45°	.080/30°	81
11402T-8	11402TB-8	2.080	.3415	.200 Longer	5.140	.290	10° x 3/8"	.080	.100/45°	-----	88
-----	11402HTB-8	2.080	.3415	.200 Longer	5.140	.290	10° x 3/8"	.080	.100/45°	-----	88
-----	11402HTBC-8	2.080	.3415	.200 Longer	5.140	.290	10° x 3/8"	.080	.060/45°	.080/30°	88
11404T-8	11404TB-8	2.080	.3415	.300 Longer	5.240	.290	10° x 3/8"	.080	.100/45°	-----	89
11408T-8	11408TB-8	2.100	.3415	.100 Longer	5.040	.290	10° x 3/8"	.080	.100/45°	-----	89
-----	11478HTB-8	2.100	.3110	.200 Longer	5.140	.290	10° x 3/8"	.080	.100/45°	-----	82
-----	11478HTBC-8	2.100	.3110	.200 Longer	5.140	.290	10° x 3/8"	.080	.060/45°	.080/30°	82
11410T-8	11410TB-8	2.100	.3415	.200 Longer	5.140	.290	10° x 3/8"	.080	.100/45°	-----	90
-----	11410HTB-8	2.100	.3415	.200 Longer	5.140	.290	10° x 3/8"	.080	.100/45°	-----	90
-----	11410HTBC-8	2.100	.3415	.200 Longer	5.140	.290	10° x 3/8"	.080	.060/45°	.080/30°	90
11412T-8	11412TB-8	2.100	.3415	.300 Longer	5.240	.290	10° x 3/8"	.080	.100/45°	-----	91
11456T-8	11456TB-8	2.100	.3415	.300 Longer	5.240	.290	12° x 7/16"	.080	.100/45°	-----	93
11462T-8	11462TB-8	2.100	.3415	.345 Longer	5.285	.290	12° x 3/8"	.080	.090/45°	.090/30°	94
11462HT-8	11462HTB-8	2.100	.3415	.345 Longer	5.285	.290	12° x 3/8"	.080	.090/45°	.090/30°	94
11414T-8	11414TB-8	2.100	.3415	.400 Longer	5.340	.290	10° x 3/8"	.080	.100/45°	-----	94
11416T-8	11416TB-8	2.100	.3415	.500 Longer	5.440	.290	10° x 3/8"	.080	.100/45°	-----	95
11446T-8	11446TB-8	2.100	.3415	.500 Longer	5.440	.290	12° x 7/16"	.080	.100/45°	-----	96
11434T-8	11434TB-8	2.100	.3415	.600 Longer	5.540	.290	10° x 3/8"	.080	.100/45°	-----	96
11442T-8	11442TB-8	2.125	.3415	.100 Longer	5.040	.290	10° x 3/8"	.080	.100/45°	-----	90
-----	11406HTB-8	2.125	.3110	.200 Longer	5.140	.290	10° x 3/8"	.080	.100/45°	-----	83
-----	11406HTBC-8	2.125	.3110	.200 Longer	5.140	.290	10° x 3/8"	.080	.060/45°	.080/30°	83
11418T-8	11418TB-8	2.125	.3415	.200 Longer	5.140	.290	10° x 3/8"	.080	.100/45°	-----	91
11420T-8	11420TB-8	2.125	.3415	.300 Longer	5.240	.290	10° x 3/8"	.080	.100/45°	-----	92
11422T-8	11422TB-8	2.125	.3415	.400 Longer	5.340	.290	10° x 3/8"	.080	.100/45°	-----	93
11424T-8	11424TB-8	2.125	.3415	.500 Longer	5.440	.290	10° x 3/8"	.080	.100/45°	-----	94
11448T-8	11448TB-8	2.125	.3415	.500 Longer	5.440	.290	12° x 7/16"	.080	.100/45°	-----	95
11436T-8	11436TB-8	2.125	.3415	.600 Longer	5.540	.290	10° x 3/8"	.080	.100/45°	-----	95
11470T-8	11470TB-8	2.125	.3415	.600 Longer	5.540	.290	12° x 7/16"	.080	.100/45°	-----	96
11428T-8	11428TB-8	2.150	.3415	.200 Longer	5.140	.290	10° x 3/8"	.080	.100/45°	-----	94
11430T-8	11430TB-8	2.150	.3415	.300 Longer	5.240	.290	10° x 3/8"	.080	.100/45°	-----	95
11432T-8	11432TB-8	2.150	.3415	.400 Longer	5.340	.290	10° x 3/8"	.080	.100/45°	-----	96
11458T-8	11458TB-8	2.150	.3415	.400 Longer	5.340	.290	12° x 7/16"	.080	.100/45°	-----	97
11426T-8	11426TB-8	2.150	.3415	.500 Longer	5.440	.290	10° x 3/8"	.080	.100/45°	-----	97
11450T-8	11450TB-8	2.150	.3415	.500 Longer	5.440	.290	12° x 7/16"	.080	.100/45°	-----	98
-----	11496HTB-8	2.150	.3110	.600 Longer	5.540	.290	12° x 3/8"	.080	.100/45°	-----	91
11438T-8	11438TB-8	2.150	.3415	.600 Longer	5.540	.290	10° x 3/8"	.080	.100/45°	-----	99
11460T-8	11460TB-8	2.150	.3415	.600 Longer	5.540	.290	12° x 7/16"	.080	.100/45°	-----	100
-----	11460HTB-8	2.150	.3415	.600 Longer	5.540	.290	12° x 7/16"	.080	.100/45°	-----	100
-----	11498HTB-8	2.150	.3110	.700 Longer	5.640	.290	12° x 3/8"	.080	.100/45°	-----	92
11476HT-8	11476HTB-8	2.150	.3415	.700 Longer	5.640	.290	12° x 3/8"	.080	.100/45°	-----	101

2.180" and 2.200" head diameter offerings continued on next page

TITANIUM VALVES

Continued from page 47

VALVES

Small Block GM, Ford & Chrysler

Titanium Intake Valves

- ▶ All valves have inserted hard tips
- ▶ "HT" suffix indicates higher hardness material
- ▶ Available with conventional square or Manley's Bead Loc® single radius keeper grooves
- ▶ "C" suffix indicates CrN seat coating (See page 53 for more details)



Square Groove Part No.	Bead Loc® Groove Part No.	Head Diameter	Stem Diameter	Installed Height	O / A Length	Tip Length	Underhead Angle / Radius	Margin	Seat Width/Angle	Wgt / Grams
11466T-8	11466TB-8	2.180	.3415	.500 Longer	5.440	.290	12° x 3/8"	.080	.100/45°	99
-----	11494HTB-8	2.180	.3110	.600 Longer	5.540	.290	12° x 3/8"	.080	.100/45°	92
-----	11444HTBC-8*	2.180	.3110	.600 Longer	5.540	.290	12° x 3/8"	.065	.060/45°	92
11468T-8	11468TB-8	2.180	.3415	.600 Longer	5.540	.290	12° x 3/8"	.080	.100/45°	100
-----	11468HTB-8	2.180	.3415	.600 Longer	5.540	.290	12° x 3/8"	.080	.100/45°	100
-----	11488HTB-8	2.180	.3110	.700 Longer	5.640	.290	12° x 3/8"	.080	.100/45°	93
11486HT-8	11486HTB-8	2.180	.3415	.700 Longer	5.640	.290	12° x 3/8"	.080	.100/45°	101
-----	11942HTB-8	2.180	.3110	.800 Longer	5.740	.290	12° x 3/8"	.080	.080/52°	94
11464T-8	11464TB-8	2.200	.3415	.600 Longer	5.540	.290	10° x 3/8"	.080	.100/45°	100

* Valve P/N 11444HTBC has a 7° dish and a back cut of .075" x 33°.

LS-7 Small Block Chevy

Titanium Intake Valves

- ▶ These valves have an inserted hard tip
- ▶ These valves have an O.E. style single radius keeper groove.
- ▶ "C" suffix indicates CrN seat coating (See page 53 for more details)

Use Manley valve lock P/N 13098-16 (7°) or 13153-16 (10°) depending on your spring/retainer choice.

Part No.	Head Diameter	Stem Diameter	Installed Height	O / A Length	Tip Length	Underhead Angle / Radius	Margin	Seat Width/Angle	Back Cut Width/Angle	Wgt / Grams
11958BC-8	2.205	.3135	Stock	5.130	.230	10° x 3/8"	.050	.090/45°	.090/30°	77
11958TBC-8	2.205	.3135	Stock	5.190	.290	10° x 3/8"	.050	.090/45°	.090/30°	78
11958TB-8	2.205	.3135	Stock	5.205	.290	12° x 3/8"	.065	.080/45°	.080/30°	78
11978TBC-8	2.250	.3135	Stock	5.190	.290	12° x 3/8"	.050	.090/45°	.090/30°	80
11978TB-8	2.250	.3135	Stock	5.205	.290	12° x 3/8"	.065	.080/45°	.080/30°	80

Note: Above LS-7 titanium intake valves have a 5° dish



Small Block Chevrolet

AFR 210cc, 220cc, 227cc, 235cc, 245cc Eliminator Racing Heads

Titanium Valves

- ▶ All valves have inserted hard tips
- ▶ All valves feature Chevy LS (.060" single radius) style keeper grooves

Use Manley valve lock P/N 13098-16 (7°) or 13153-16 (10°) depending on your spring/retainer choice.

Manley stem size is .3135". AFR heads have guides sized to .3147" (nominal). Manley strongly recommends that all guides be checked and correctly sized for the Manley valve stem sizes listed to achieve the proper clearances.

Part No.	Type	Head Diameter	Stem Diameter	Installed Height	O / A Length	Tip Length	Underhead Angle / Radius	Margin	Seat Width	Wgt / Grams
11967TB-8	Exh.	1.600"	.3135"	Stock	5.090"	.290"	25° x 7/16"	.080	.100	75
11968TB-8	Int.	2.080"	.3135"	Stock	5.080"	.290"	12° x 3/8"	.070	.100	88
11970TB-8	Int.	2.100"	.3135"	Stock	5.080"	.290"	12° x 3/8"	.070	.100	90
11982TB-8	Int.	2.125"	.3135"	Stock	5.080"	.290"	12° x 3/8"	.070	.100	92

Note: New part numbers are **BOLD & ITALICIZED**



All Pro, Brodix ASCS & GB Heads

- ▶ All valves (except P/N 12218HBC-8) have inserted hard tips and Manley's Bead Loc® single radius keeper groove
- ▶ All exhaust valves are "HT" high temperature material (except P/N's 11421TB, 11427TB and 11437TB)
- ▶ All intake valves are "HT" higher hardness material
- ▶ "C" suffix indicates CrN seat coating (See page 53 for more details)



VALVES

Part No.	Type	Head Diam.	Stem Diam.	Installed Height	O / A Length	Tip Length	Underhead Angle / Radius	Margin	Seat Width/Angle	Back Cut Width/Angle	Wgt / Grams
EXHAUST VALVES											
11421TB-8	ASCS	1.600	.3110	.200 Longer	5.140	.290	20° x 7/16"	.080	.100/45°	-----	68
11427TB-8	ASCS	1.600	.3415	.200 Longer	5.140	.290	20° x 7/16"	.080	.100/45°	-----	74
11427HTB-8	ASCS	1.600	.3415	.200 Longer	5.140	.290	20° x 7/16"	.080	.100/45°	-----	74
11437TB-8	ASCS	1.625	.3415	.200 Longer	5.140	.290	20° x 7/16"	.080	.100/45°	-----	74
11969HTB-8	ALL PRO	1.600	.3110	Stock	5.950	.300	20° x 3/4"	.080	.065/45°	-----	71
11971HTB-8	ALL PRO	1.625	.3110	Stock	5.950	.300	20° x 3/4"	.080	.065/45°	-----	72
11991HTB-8	ALL PRO	1.600	.3110	Stock	5.950	.300	20° x 3/4"	.080	.065/55°	-----	71
11993HTB-8	ALL PRO	1.625	.3110	Stock	5.950	.300	20° x 3/4"	.080	.065/55°	-----	72
11961HTB-8	ALL PRO	1.600	.3415	Stock	5.950	.300	20° x 3/4"	.080	.065/45°	-----	77
11973HTB-8	ALL PRO	1.625	.3415	Stock	5.950	.300	20° x 3/4"	.080	.065/45°	-----	78
12215HTBC-8	ALL PRO	1.600	.3110	Stock	6.090	.300	20° x 3/4"	.080	.065/55°	-----	75
11975HTB-8	GB 2000	1.600	.3110	Stock	6.090	.300	25° x 3/4"	.080	.065/45°	-----	73
11963HTB-8	GB 2000	1.600	.3415	Stock	6.090	.300	25° x 3/4"	.080	.065/45°	-----	80
11977HTB-8	GB 2300	1.600	.3110	Stock	6.250	.300	25° x 3/4"	.080	.065/45°	-----	78
11965HTB-8	GB 2300	1.600	.3415	Stock	6.250	.300	25° x 3/4"	.080	.065/45°	-----	85
INTAKE VALVES											
11472HTB-8	ASCS	2.080	.3110	.200 Longer	5.140	.290	10° x 3/8"	.080	.100/45°	-----	81
11472HTBC-8	ASCS	2.080	.3110	.200 Longer	5.140	.290	10° x 3/8"	.080	.060/45°	.080/30°	81
11478HTB-8	ASCS	2.100	.3110	.200 Longer	5.140	.290	10° x 3/8"	.080	.100/45°	-----	82
11478HTBC-8	ASCS	2.100	.3110	.200 Longer	5.140	.290	10° x 3/8"	.080	.060/45°	.080/30°	82
11402HTB-8	ASCS	2.080	.3415	.200 Longer	5.140	.290	10° x 3/8"	.080	.100/45°	-----	88
11402HTBC-8	ASCS	2.080	.3415	.200 Longer	5.140	.290	10° x 3/8"	.080	.060/45°	.080/30°	88
11410HTB-8	ASCS	2.100	.3415	.200 Longer	5.140	.290	10° x 3/8"	.080	.100/45°	-----	90
11410HTBC-8	ASCS	2.100	.3415	.200 Longer	5.140	.290	10° x 3/8"	.080	.060/45°	.080/30°	90
11406HTB-8	ASCS	2.125	.3110	.200 Longer	5.140	.290	10° x 3/8"	.080	.100/45°	-----	83
11406HTBC-8	ASCS	2.125	.3110	.200 Longer	5.140	.290	10° x 3/8"	.080	.060/45°	.080/30°	83
11972HTB-8	ALL PRO	2.180	.3110	Stock	5.950	.300	10° x 3/8"	.080	.050/45°	.080/33°	88
11972HTBC-8	ALL PRO	2.180	.3110	Stock	5.950	.300	10° x 3/8"	.080	.050/45°	.080/33°	88
11974HTB-8	ALL PRO	2.180	.3110	Stock	5.950	.300	12° x 3/8"	.080	.050/52°	.080/35°	90
11974HTBC-8	ALL PRO	2.180	.3110	Stock	5.950	.300	12° x 3/8"	.080	.050/52°	.080/35°	90
11960HTB-8	ALL PRO	2.200	.3110	Stock	5.950	.300	10° x 3/8"	.080	.050/45°	.080/33°	90
11960HTBC-8	ALL PRO	2.200	.3110	Stock	5.950	.300	10° x 3/8"	.080	.050/45°	.080/33°	90
11960HTBCH-8	ALL PRO	2.200	.3110	Stock	5.950	.300	10° x 3/8"	.080	.050/45°	.080/33°	76
Hollow Stem with Fluted Dish											
11976HTB-8	ALL PRO	2.200	.3110	Stock	5.950	.300	12° x 3/8"	.080	.050/52°	.080/35°	92
11976HTBC-8	ALL PRO	2.200	.3110	Stock	5.950	.300	12° x 3/8"	.080	.050/52°	.080/35°	92
11976HTBCH-8	ALL PRO	2.200	.3110	Stock	5.950	.300	12° x 3/8"	.080	.050/52°	.080/35°	78
Hollow Stem with Fluted Dish											
11980HTBC-8	ALL PRO	2.230	.3110	Stock	5.950	.300	12° x 3/8"	.080	.050/52°	.080/35°	93
12218HBC-8	ALL PRO	2.200	.2754	Stock	6.030	.230	12° x 3/8"	.060	.055/52°	.080/35°	87
12220HTBC-8	ALL PRO	2.200	.3110	Stock	6.090	.300	12° x 3/8"	.060	.055/52°	.080/35°	94
11962HTB-8	GB 2000	2.200	.3110	Stock	6.090	.300	12° x 3/8"	.080	.050/45°	.080/33°	91
11962HTBC-8	GB 2000	2.200	.3110	Stock	6.090	.300	12° x 3/8"	.080	.050/45°	.080/33°	91
11964HTB-8	GB 2300	2.200	.3110	Stock	6.250	.300	12° x 3/8"	.080	.050/45°	.080/33°	92
11964HTBC-8	GB 2300	2.200	.3110	Stock	6.250	.300	12° x 3/8"	.080	.050/45°	.080/33°	92
11966HTB-8	GB 2300	2.200	.3110	Stock	6.250	.300	12° x 3/8"	.080	.050/52°	.080/35°	92
11966HTBC-8	GB 2300	2.200	.3110	Stock	6.250	.300	12° x 3/8"	.080	.050/52°	.080/35°	92
11988HTBC-8	GB 2300	2.230	.3110	Stock	6.250	.300	12° x 3/8"	.080	.050/52°	.080/35°	93

TITANIUM VALVES

VALVES

M&M Revolution

▶ These valves feature Manley's Bead Loc® single radius keeper grooves

These valves do not come with a hardened tip. Tip protection is required – Manley wear cap P/N 42139 or 42139TM



Part No.	Type	Head Diam.	Stem Diam.	Installed Height	O / A Length	Tip Length	Underhead Angle / Radius	Margin	Seat Width/Angle	Back Cut Width/Angle	Wgt / Grams
11995B-8	Exh.	1.600	.3110	Stock	6.070	.250	25° x 3/8"	.075	.090/55°	.050/42°	72
11996B-8	Int.	2.250	.3110	Stock	6.170	.250	12° x 3/8"	.070	.050/50°	.100/35°	99

Big Block General Motors

▶ "H" suffix indicates higher hardness material

▶ Available with conventional square or Manley's Bead Loc® single radius keeper grooves

All part numbers without a "T" suffix do not include a hard tip. Tip protection is required. Manley wear cap P/N 42104 or 42104TM.



Square Groove Part No.	Bead Loc® Groove Part No.	Type	Head Diameter	Stem Diameter	Installed Height	O / A Length	Tip Length	Underhead Angle / Radius	Margin	Seat Width	Wgt / Grams
11485-8	11485B-8	Exh.	1.840	.3415	Stock	5.440	.250	30° x 5/8"	.090	.075	98
11479-8	11479B-8	Exh.	1.880	.3415	Stock	5.440	.250	30° x 5/8"	.090	.075	100
11481-8	11481B-8	Exh.	1.900	.3415	Stock	5.440	.250	30° x 5/8"	.090	.075	101
11483-8	11483B-8	Exh.	1.900	.3415	.100 Longer	5.540	.250	30° x 5/8"	.090	.075	102
11480-8	11480B-8	Int.	2.250	.3415	Stock	5.250	.250	10° x 3/8"	.065	.075	89
11490-8	11490B-8	Int.	2.250	.3415	.100 Longer	5.350	.250	10° x 3/8"	.065	.075	90
11490T-8	11490TB-8	Int.	2.250	.3415	.100 Longer	5.350	.290	10° x 3/8"	.065	.075	90
11492-8	11492B-8	Int.	2.250	.3415	.250 Longer	5.500	.250	10° x 3/8"	.065	.075	91
11492T-8	11492TB-8	Int.	2.250	.3415	.250 Longer	5.540	.290	10° x 3/8"	.065	.075	92
11952-8	11952B-8	Int.	2.250	.3415	.350 Longer	5.600	.250	10° x 3/8"	.065	.075	93
11944T-8	11944TB-8	Int.	2.300	.3415	.100 Longer	5.350	.290	10° x 3/8"	.065	.075	94
11482-8	11482B-8	Int.	2.300	.3415	.250 Longer	5.500	.250	10° x 3/8"	.065	.075	95
11482H-8	11482HB-8	Int.	2.300	.3415	.250 Longer	5.500	.250	10° x 3/8"	.065	.075	95
11482T-8	11482TB-8	Int.	2.300	.3415	.250 Longer	5.540	.290	10° x 3/8"	.065	.075	96
11940-8	11940B-8	Int.	2.325	.3415	.250 Longer	5.500	.250	10° x 3/8"	.065	.075	96
11940H-8	11940HB-8	Int.	2.325	.3415	.250 Longer	5.500	.250	10° x 3/8"	.065	.075	96
11484-8	11484B-8	Int.	2.350	.3415	.250 Longer	5.500	.250	10° x 3/8"	.065	.075	97
11954-8	11954B-8	Int.	2.350	.3415	.350 Longer	5.600	.250	10° x 3/8"	.065	.075	99
11954H-8	11954HB-8	Int.	2.350	.3415	.350 Longer	5.600	.250	10° x 3/8"	.065	.075	99
-----	11946HB-8*	Int.	2.350	.3415	.400 Longer	5.650	.250	10° x 3/8"	.065	.050	100

* Valve P/N 11946HB has a 50° seat and a back cut of .080" x 32°.

Brodix Big Block SR20 / Dart 20° / M&M X20 Heads

▶ "H" suffix indicates higher hardness material

▶ All valves have Manley's Bead Loc® single radius keeper groove

All P/N's without a "T" suffix do not include a hard tip. Tip protection is required.



Part No.	Type	Head Diameter	Stem Diameter	Installed Height	O / A Length	Tip Length	Underhead Angle / Radius	Margin	Seat Width/Angle	Back Cut Width/Angle	Wgt / Grams
12209TB-8	Exh.	1.800	.3415	Stock	5.930	.290	30° x 5/8"	.080	.075/55°	-----	93
12213B-8	Exh.	1.800	.3415	.100 Longer	6.010	.250	25° x 3/4"	.085	.060/50°	-----	92
12175B-8**	Exh.	1.850	.3110	Stock	5.975	.250	30° x 3/8"	.075	.070/55°	.025/42°	90
12208HTB-8*	Int.	2.400	.3415	Stock	6.040	.290	12° x 7/16"	.065	.060/50°	.060/45°	123
12210HTB-8*	Int.	2.400	.3415	Stock	6.035	.290	12° x 7/16"	.060	.060/55°	.060/45°	121
12216HB-8	Int.	2.400	.3415	.100 Longer	6.125	.250	12° x 3/8"	.050	.080/50°	.090/33°	112
12174B-8**	Int.	2.450	.3110	Stock	6.160	.250	12° x 3/8"	.070	.050/50°	.080/35°	111

* Valve P/N's 12208HTB and 12210HTB have a second back cut of .100" x 35°

** Valve P/N's 12174B-8 and 12175B-8 fit M&M X20 cylinder heads.

Dart Big Block Pro 1® & 320 / 360 Heads

- ▶ "H" suffix indicates higher hardness material
- ▶ Available with conventional square or Manley's Bead Loc® single radius keeper grooves

All part numbers without a "T" suffix do not include a hard tip. Tip protection is required. Manley wear cap P/N 42104 or 42104TM.



Square Groove Part No.	Bead Loc® Groove Part No.	Type	Head Diameter	Stem Diameter	Installed Height	O / A Length	Tip Length	Underhead Angle / Radius	Margin	Seat Width	Wgt / Grams
11479-8	11479B-8	Exh.	1.880	.3415	Stock	5.440	.250	30° x 5/8"	.090	.075	100
11481-8	11481B-8	Exh.	1.900	.3415	Stock	5.440	.250	30° x 5/8"	.090	.075	101
11492-8	11492B-8	Int.	2.250	.3415	.250 Longer	5.500	.250	10° x 3/8"	.065	.075	91
11492T-8	11492TB-8	Int.	2.250	.3415	.250 Longer	5.540	.290	10° x 3/8"	.065	.075	92
11482-8	11482B-8	Int.	2.300	.3415	.250 Longer	5.500	.250	10° x 3/8"	.065	.075	95
11482H-8	11482HB-8	Int.	2.300	.3415	.250 Longer	5.500	.250	10° x 3/8"	.065	.075	95
11482T-8	11482TB-8	Int.	2.300	.3415	.250 Longer	5.540	.290	10° x 3/8"	.065	.075	96

Pontiac Pro Stock & Dart Big Chief

- ▶ "H" suffix indicates higher hardness material
- ▶ Available with conventional square or Manley's Bead Loc® single radius keeper grooves

All part numbers without a "T" suffix do not include a hard tip. Tip protection is required. Manley wear cap P/N 42104 or 42104TM.



Square Groove Part No.	Bead Loc® Groove Part No.	Type	Head Diameter	Stem Diameter	Installed Height	O / A Length	Tip Length	Underhead Angle / Radius	Margin	Seat Width	Wgt / Grams
11925-8*	-----	Exh.	1.840	.3415	.100 Longer	6.550	.250	30° x 5/8"	.125	.075	110
11921-8	11921B-8	Exh.	1.900	.3415	Stock	6.450	.250	30° x 5/8"	.125	.075	116
11923T-8	11923TB-8	Exh.	1.900	.3415	Stock	6.490	.290	30° x 5/8"	.125	.075	117
11920-8	11920B-8	Int.	2.400	.3415	Stock	6.600	.250	12° x 3/8"	.065	.075	112
11920H-8	11920HB-8	Int.	2.400	.3415	Stock	6.600	.250	12° x 3/8"	.065	.075	112
11922T-8	11922TB-8	Int.	2.400	.3415	Stock	6.640	.290	12° x 3/8"	.065	.075	113
11924-8	11924B-8	Int.	2.450	.3415	Stock	6.600	.250	12° x 3/8"	.065	.075	114
11926H-8*	-----	Int.	2.470	.3415	.100 Longer	6.700	.250	12° x 3/8"	.065	.075	118

*Valve P/N's 11925 and 11926H have a 55° seat angle.

Briggs & Stratton

*Dimensions are per customer specifications.

Part No.	Type	Head Diameter	Stem Diameter	Installed Height	O / A Length	Tip Length	Underhead Angle / Radius	Margin	Seat Width	Wgt / Grams
98031-1	Exh.	1.500 Max	.2475	*	4.800 Max	*	5° x 5/16" Max.	*	*	
98030-1	Int.	2.000 Max	.2475	*	4.800 Max	*	5° x 5/16" Max.	*	*	
98032-1	Int.	2.000 Max	.2740	*	4.800 Max	*	5° x 5/16" Max.	*	*	

Note: Manley Performance can custom build valves for any possible combination with a very short lead time. Please call your sales representative.



TFD, TFFC & Nostaglia

- ▶ "B" suffix indicates a Bead Loc® keeper groove

These valves do not come with a hardened tip. Tip protection is required - Manley wear cap P/N 42104, 42104TM or Manley LocCap System

Part No.	Type	Head Diam.	Stem Diam.	Installed Height	O / A Length	Tip Length	Underhead Angle/Radius	Margin	Seat Width/Angle	Back Cut Width/Angle	Wgt / Grams
EXHAUST VALVES											
11989-8	AJPE 4/5	2.000	.3415	.100 Longer	5.020	.250	25° x 3/8"	.085	.075/45°	-----	100
INTAKE VALVES											
11956-8	AJPE 4/5	2.375	.3415	.100 Longer	5.600	.250	25° x 5/8"	.065	.075/45°	-----	139
11994B-8	AJPE 4/5	2.400	.3415	.100 Longer	5.600	.250	25° x 5/8"	.070	.125/45°	-----	141
11998B-8	AJPE 4/5	2.400	.3415	.200 Longer	5.700	.250	25° x 5/8"	.080	.125/45°	-----	142
11992-8	AJPE 6	2.450	.3415	.100 Longer	5.600	.250	19° x 7/16"	.070	.155/45°	.075/32°	138
11992B-8	AJPE 6	2.450	.3415	.100 Longer	5.600	.250	19° x 7/16"	.070	.155/45°	.075/32°	138

Note: Manley Performance can custom build valves for any possible combination with a very short lead time. Please call your sales representative.

TITANIUM VALVES

VALVES



TAD, TAFC & Pro Mod

- ▶ "H" suffix indicates higher hardness material
- ▶ "B" suffix indicates a Bead Loc® keeper groove
- ▶ "C" suffix indicates Premium CrN seat coating (See page 53 for more details)

These valves do not come with a hardened tip. Tip protection is required - Manley wear cap P/N 42104, 42104TM or Manley LocCap System when using a .250" tip length

Part No.	Type	Head Diam.	Stem Diam.	Installed Height	O / A Length	Tip Length	Underhead Angle/Radius	Margin	Seat	Back Cut	Dish	Wgt / Grams
EXHAUST VALVES												
12111-8	BAE 4	1.950	.3415	Stock	5.845	.250	30° x 5/8"	.095	.100/45°	-----	Flat	107
12113-8	BAE 5	1.950	.3415	Stock	6.032	.250	30° x 5/8"	.085	.130/45°	-----	17°	96
12113B-8	BAE 5	1.950	.3415	Stock	6.032	.250	30° x 5/8"	.085	.130/45°	-----	17°	96
12117-8	BAE 6/8/8X	1.900	.3415	Stock	6.100	.250	30° x 5/8"	.110	.080/50°	-----	17°	96
12117B-8	BAE 6/8/8X	1.900	.3415	Stock	6.100	.250	30° x 5/8"	.110	.080/50°	-----	17°	96
12161C-8	BAE TA1	1.925	.3415	Stock	6.100	.250	30° x 5/8"	.110	.085/55°	-----	19°	100
12161BC-8	BAE TA1	1.925	.3415	Stock	6.100	.250	30° x 5/8"	.110	.085/55°	-----	19°	100
12165C-8	BAE TA1	1.925	.3415	Stock	6.100	.250	30° x 5/8"	.110	.085/55°	-----	Flat	112
12167C-8	TA1 NHRA	1.900	.3415	.100 Longer	6.200	.250	30° x 5/8"	.110	.080/55°	-----	17°	100
12167BC-8	TA1 NHRA	1.900	.3415	.100 Longer	6.200	.250	30° x 5/8"	.110	.080/55°	-----	17°	100
12163C-8	BAE TA1	1.925	.3415	.100 Longer	6.200	.250	30° x 5/8"	.110	.085/55°	-----	19°	101
12163BC-8	BAE TA1	1.925	.3415	.100 Longer	6.200	.250	30° x 5/8"	.110	.085/55°	-----	19°	101
12169BC-8	BAE TA1	1.925	.3415	.100 Longer	6.200	.250	30° x 5/8"	.110	.085/55°	-----	Flat	113

INTAKE VALVES												
12110-8	BAE 4/5	2.425	.3415	Stock	6.400	.400	12° x 3/8"	.070	.070/45°	.130/32°	Flat	122
12110B-8	BAE 4/5	2.425	.3415	Stock	6.400	.400	12° x 3/8"	.070	.070/45°	.130/32°	Flat	122
12114HC-8*	TA1 NHRA	2.400	.3415	Stock	6.400	.250	12° x 7/16"	.085	.075/55°	.060/45°	7°	127
12114HBC-8*	TA1 NHRA	2.400	.3415	Stock	6.400	.250	12° x 7/16"	.085	.075/55°	.060/45°	7°	127
12116HB-8*	BAE 6	2.400	.3415	Stock	6.400	.250	12° x 7/16"	.085	.075/50°	.060/45°	Flat	133
12118H-8*	BAE 8/8X	2.450	.3415	Stock	6.400	.250	12° x 7/16"	.085	.075/50°	.060/45°	Flat	137
12118HB-8*	BAE 8/8X	2.450	.3415	Stock	6.400	.250	12° x 7/16"	.085	.075/50°	.060/45°	Flat	137
12160H-8*	BAE TA1	2.500	.3415	Stock	6.400	.250	12° x 7/16"	.060	.060/50°	.045/45°	7°	125
12160HB-8*	BAE TA1	2.500	.3415	Stock	6.400	.250	12° x 7/16"	.060	.060/50°	.045/45°	7°	125
12164H-8*	BAE TA1	2.500	.3415	Stock	6.400	.250	12° x 7/16"	.060	.060/50°	.045/45°	Flat	131
12162H-8*	BAE TA1	2.500	.3415	.075 Longer	6.475	.250	12° x 7/16"	.060	.060/50°	.045/45°	7°	126
12162HB-8*	BAE TA1	2.500	.3415	.075 Longer	6.475	.250	12° x 7/16"	.060	.060/50°	.045/45°	7°	126
12166H-8*	BAE TA1	2.500	.3415	.075 Longer	6.475	.250	12° x 7/16"	.060	.060/50°	.045/45°	Flat	132
12166HB-8*	BAE TA1	2.500	.3415	.075 Longer	6.475	.250	12° x 7/16"	.060	.060/50°	.045/45°	Flat	132

* Valve P/N's 12114HC, 12114HBC, 12116HB, 12118H, 12118HB, 12160H, 12160HB, 12162H, 12162HB, 12164H, 12166H, and 12166HB have a second back cut of .075" x 32°



TAD, TAFC & Pro Mod

- ▶ "H" suffix indicates higher hardness material
- ▶ "B" suffix indicates a Bead Loc® keeper groove
- ▶ "C" suffix indicates Premium CrN seat coating (See page 53 for more details)

These valves do not come with a hardened tip. Tip protection is required - Manley wear cap P/N 42104, 42104TM or Manley LocCap System

Part No.	Type	Head Diam.	Stem Diam.	Installed Height	O / A Length	Tip Length	Underhead Angle/Radius	Margin	Seat	Back Cut	Dish	Wgt / Grams
EXHAUST VALVES												
12201B-8	X1/Super 6	1.950	.3415	Stock	6.200	.250	30° x 5/8"	.110	.080/55°	-----	18.66°	99
12201BC-8	X1/Super 6	1.950	.3415	Stock	6.200	.250	30° x 5/8"	.110	.080/55°	-----	18.66°	99
12203B-8	X1 Pro Mod	1.900	.3415	Stock	6.200	.250	30° x 5/8"	.110	.080/55°	-----	18.66°	95
INTAKE VALVES												
12200HBC-8*	X1/Super 6	2.480	.3415	Stock	6.400	.250	12° x 7/16"	.070	.060/55°	.050/44°	6.73°	120
12212HBC-8*	X1/Super 6	2.550	.3415	Stock	6.400	.250	12° x 7/16"	.070	.060/55°	.050/44°	6.73°	126
12202HBC-8*	X1 Pro Mod	2.400	.3415	Stock	6.400	.250	12° x 7/16"	.070	.060/55°	.050/44°	6.73°	115

* Valve P/N's 12200HBC, 12202HBC and 12212HBC have a second back cut of .060" x 32°

CUSTOM TITANIUM VALVES

Manley Performance can manufacture titanium valves for just about any application imaginable. Servicing your custom requirements is our specialty; we do it every single day and typically 8 pieces at a time.

We inventory an extensive selection of blanks in varying stem sizes with the stem coating correctly positioned to properly fit the multitude of aftermarket cylinder heads available. This allows us to maintain reliable and very reasonable turnaround times (typically 10 working days) throughout the year. If by chance we don't have a blank in stock to match your particular application, then don't worry. We'll simply make it! This will lengthen the lead-time to 6 weeks.

For any stem size, groove type, machined (dished) combustion face or special head shape or seat cut, we're here to service your needs. Our customers' prints are proprietary and confidential.



Fluted Dish

Ordering Manley Custom Titanium Valves is as easy as 1-2-3!

1. Refer to the blank valve print on page 45 of this catalog or on our website under the custom valve tab and fill in your desired specifications.
2. Please contact your inside or outside Manley salesperson to review your order.
3. Fax or email your approved prints to the factory for processing, specifying your account number, a purchase order number and quantity.

Custom Hollow Stem Titanium Intake Valves

- ▶ Precision gun drilling
- ▶ Smooth surface finish
- ▶ Full radius at end of bore, no stress raisers
- ▶ Able to utilize a hard tool steel tip on 5/16" and larger stem diameter valves
- ▶ Extremely lightweight - 10-12% weight reduction

Titanium Valve CrN Seat Face Coating

- ▶ High hardness and lubricity prevents valve seat face wear
- ▶ Prevents "trenching" of the seat face which maintains combustion seal
- ▶ Provides greater resistance to wear typically seen when valve float or dirt is present in the engine
- ▶ Better seal between the valve seat face and the seat in the cylinder head equals more horsepower

Manley Performance offers a premium (Calico) CrN seat coating option which incorporates an advanced superpolish process rendering a jewel-like surface finish

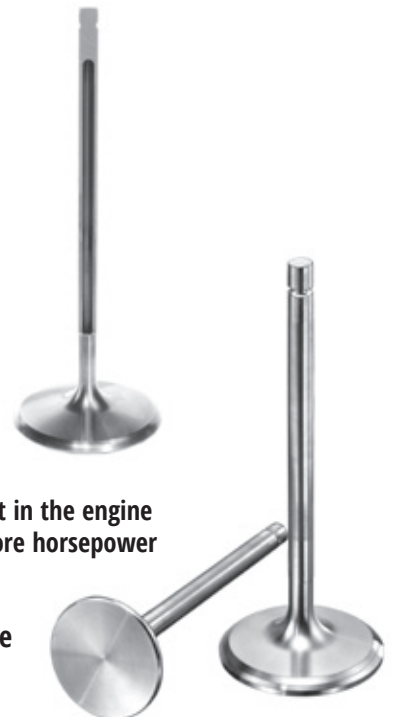

We offer certain shelf stock part numbers with CrN seat coating; look for the "C" suffix

Titanium valve "tip" coating is also available for applications not utilizing a "press in" hard tip (prevents tip wear from lash cap)

Custom titanium valves with a premium CrN slick stem coating (in lieu of moly) are also available

Contact your salesperson for ordering details