

Small Block Chevrolet Crankshafts

4340 Non-Twist Forgings

Lightweight Design for Internal Balance

2 Piece Rear Seal

- ▶ Heat treated, stress relieved, shot peened, nitrided and 100% magnafluxed
- ▶ Micro polished large radius journals (narrowed rod bearings required)

Part No.	Stroke	Minimum Rod Length	Main Journal Diameter	Rod Journal Diameter	Bobweight (grams)	Total Weight (lbs.)
350 MAIN JOURNAL DIAMETER						
190190	3.480"	5.700"	2.450"	2.100"	1750	44-46
190310*	3.480"	5.700"	2.450"	2.100"	1800	48-50
190310NB *	3.480"	5.700"	2.450"	2.100"	See Note**	48-50
190150	3.750"	5.700"	2.450"	2.100"	1800	49-51
190150NB	3.750"	5.700"	2.450"	2.100"	See Note**	49-51
190480	3.875"	6.000"	2.450"	2.100"	1800	49-51
190480NB	3.875"	6.000"	2.450"	2.100"	See Note**	49-51
190130	4.000"	6.000"	2.450"	2.100"	1800	49-51
190130NB	4.000"	6.000"	2.450"	2.100"	See Note**	49-51

* The two center rod journals are not gun drilled

** These cranks are not balanced and have non-drilled counterweights

Note: Manley crankshafts are not intended for use with highly boosted roots style cog belt superchargers

Precision Balancing Information

Part No.	Bobweight Modification
04004-1	Precision balancing the crankshaft from -200 to -71 grams from the published bobweight
04000-1	Precision balancing the crankshaft from -70 to +20 grams from the published bobweight
04005-1	Precision balancing the crankshaft from +21 to +80 grams from the published bobweight
04006-1	Precision balancing the crankshaft from +81 to +160 grams from the published bobweight



Small Block Chevrolet

Rotating Assemblies

- ▶ Lightweight 4340 forged steel crankshaft
- ▶ 4340 Forged steel H-Beam connecting rods with 7/16" ARP 8740 or optional ARP 2000 cap screws*
- ▶ 2618 Forged aluminum Platinum Series pistons with Premium Chrome Moly wrist pins
- ▶ Total Seal® piston rings & high performance Clevite® "H" Series rod bearings (narrowed) and "P" or "H" Series main bearings
- ▶ Horsepower range is 750 with the ARP 8740 and 1,500 with the optional ARP 2000 cap screws

Note: The 350 and 400 Small Block rotating assemblies listed below are unbalanced. For a precision balanced assembly please also order part number 04000-1

Part No.	Stroke	CID @ .030	Crank Number	Rod Length	Rod Number	Piston Type	STD. Bore	Piston Number	Bore Sizes Available	Compression Ratio			Piston Ring Numbers	Piston Ring Package
										58cc	64cc	76cc		
350 BLOCK WITH 350 MAIN JOURNAL DIAMETER														
2907	3.480"	355	190190	6.000"	14054	Flat -4cc	4.000"	5906	30 35 40 60	11.2	10.4	9.1	4635 3 5 4 6	1/16", 3/16"
2908	3.480"	355	190190	6.000"	14354	Flat -4cc	4.000"	5906	30 35 40 60	11.2	10.4	9.1	4635 3 5 4 6	1/16", 3/16"
2900	3.750"	383	190150	6.000"	14054	Dish -15cc	4.000"	5909	30 35 40	10.5	9.8	8.8	4635 3 5 4	1/16", 3/16"
2901	3.750"	383	190150	6.000"	14054	Flat -4cc	4.000"	5908	30 35 40	11.9	11.0	9.7	4635 3 5 4	1/16", 3/16"
2909	3.750"	383	190150	6.000"	14054	Dome +11cc (Gas Ported)	4.000"	5919	30 35 40 60	14.9	13.5	11.5	4622 3 5 4 6	.043", 3mm
400 BLOCK WITH 350 MAIN JOURNAL DIAMETER														
2902	4.000"	434	190130	6.000"	14054	Dish -20cc	4.125"	5939	00 30	11.0	10.3	9.3	4616 0 3	1/16", 3/16"
2903	4.000"	434	190130	6.000"	14054	Dome +4cc (Gas Ported)	4.125"	5938	00 30	14.7	13.5	11.7	4626 0 3	.043", 3mm

* Kit number 2908 is supplied with our Pro Series Lightweight I-Beam connecting rods with 7/16" ARP 2000 cap screws

Note: Specify desired bore size to complete the six digit part number, i.e. P/N 290735

Add an "R" to the assembly part number to order the optional ARP 2000 rod bolt upgrade

Add an "H" to the assembly part number to order the optional "H" Series main bearings

Add an "X" to the assembly part number to order the optional "X" Series rod bearings with .001" extra clearance

Bearing Chart

Clevite® "H" Series Rod Bearings	Clevite® "HX" Series Rod Bearings	Clevite® "P" Series Main Bearings	Clevite® "H" Series Main Bearings
30010	30010X	33010	33010H

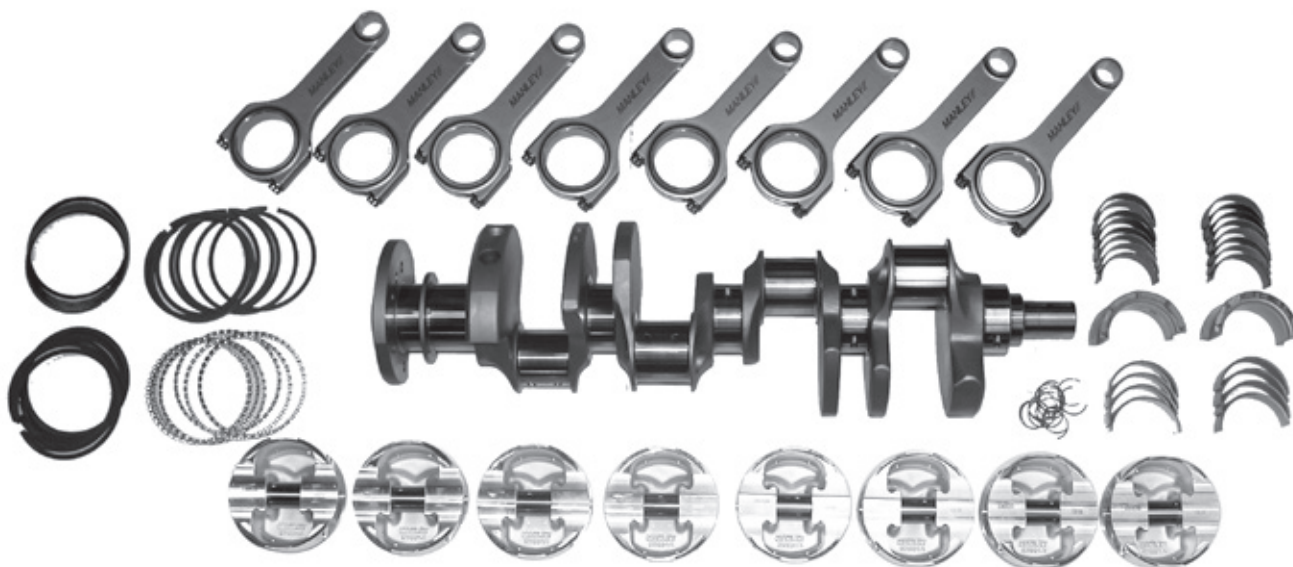

CRANKS & KITS

Big Block Chevrolet Crankshafts

4340 Non-Twist Forgings Designed for Internal Balance

2 Piece Rear Seal

- ▶ Heat treated, stress relieved, shot peened, nitrided and 100% magnafluxed
- ▶ Micro polished large radius journals (narrowed rod bearings required)

Part No.	Stroke	Minimum Rod Length	Main Journal Diameter	Rod Journal Diameter	Bobweight (grams)	Total Weight (lbs.)
454 MAIN JOURNAL DIAMETER WITHOUT CENTER COUNTERWEIGHTS						
190170	4.000"	6.385"	2.750"	2.200"	2350	64-66
190140	4.250"	6.385"	2.750"	2.200"	2350	64-66
190250	4.375"	6.535"	2.750"	2.200"	2350	64-66



454 MAIN JOURNAL DIAMETER WITH CENTER COUNTERWEIGHTS						
190290	4.250"	6.385"	2.750"	2.200"	2350	74-76
190320	4.375"	6.535"	2.750"	2.200"	2350	74-76
190220	4.500"	6.700"	2.750"	2.200"	2425	74-76
190400	4.625"	6.700"	2.750"	2.200"	2425	74-76
190280	4.750"	6.700"	2.750"	2.200"	2425	74-76



Note: Manley crankshafts are not intended for use with highly boosted roots style cog belt superchargers

Precision Balancing Information

Part No.	Bobweight Modification
04004-1	Precision balancing the crankshaft from -200 to -71 grams from the published bobweight
04000-1	Precision balancing the crankshaft from -70 to +20 grams from the published bobweight
04005-1	Precision balancing the crankshaft from +21 to +80 grams from the published bobweight
04006-1	Precision balancing the crankshaft from +81 to +160 grams from the published bobweight

See Page 169
For Big Block
Rotating Assemblies



Big Block Chevrolet

Rotating Assemblies

- ▶ 4340 Forged steel crankshaft
- ▶ 4340 Forged steel H-Beam connecting rods with 7/16" ARP 8740 or optional ARP 2000 cap screws
- ▶ 2618 Forged aluminum Platinum Series pistons with Premium Chrome Moly wrist pins
- ▶ Total Seal® piston rings & high performance Clevite® "H" Series rod (narrowed) and "P" or "H" Series main engine bearings
- ▶ Horsepower range is 900 with the ARP 8740 and 1,500 with the optional ARP 2000 cap screws

Note: All 4.000" to 4.375" stroke kits are for standard deck blocks and all 4.500" to 4.750" stroke kits are for tall deck blocks

Part No.	Stroke	CID	Crank P/N	Rod Length	Rod P/N	Bore Size	Piston P/N	Piston Type	Compression Ratio			Piston Ring Package	Piston Ring P/N
									112cc	118cc	124cc		
STANDARD DECK BLOCKS WITHOUT CENTER COUNTERWEIGHTS													
29516	4.000"	516	190170	6.385"	14062	4.530"	698330	Dome +2cc	9.4	9.0	8.7	1/16", 3/16"	4 6 4 5 3
28548**	4.250"	548	190140	6.385"	14062	4.530"	696730	Dish -20cc	8.7	8.4	8.1	1/16", 3/16"	4 6 4 5 3
28555**	4.250"	555	190140	6.385"	14062	4.560"	696360	Flat -3cc	9.8	9.4	9.0	1/16", 3/16"	4 6 4 5 6
29555	4.250"	555	190140	6.385"	14062	4.560"	697860*	Dome +43cc	14.7	13.8	13.0	.043", 3/16"	4 6 5 5 6
28565	4.250"	565	190140	6.385"	14062	4.600"	696380	Flat -3cc	9.9	9.5	9.1	1/16", 3/16"	4 6 4 5 8
29565	4.250"	565	190140	6.385"	14062	4.600"	697880*	Dome +43cc	14.9	14.0	13.2	.043", 3/16"	4 6 5 5 8
28572	4.250"	572	190140	6.385"	14062	4.625"	696390	Flat -3cc	10.0	9.6	9.2	1/16", 3/16"	4 6 4 5 9
29572	4.250"	572	190140	6.385"	14062	4.625"	697890*	Dome +43cc	15.1	14.1	13.3	.043", 3/16"	4 6 5 5 9
29582**	4.375"	582	190250	6.535"	14066	4.600"	698280*	Dome +43cc	15.3	14.4	13.5	.043", 3/16"	4 6 5 5 8
STANDARD DECK BLOCKS WITH CENTER COUNTERWEIGHTS													
38548**	4.250"	548	190290	6.385"	14062	4.530"	696730	Dish -20cc	8.7	8.4	8.1	1/16", 3/16"	46453
38555**	4.250"	555	190290	6.385"	14062	4.560"	696360	Flat -3cc	9.8	9.4	9.0	1/16", 3/16"	46456
39555	4.250"	555	190290	6.385"	14062	4.560"	697860*	Dome +43cc	14.7	13.8	13.0	.043", 3/16"	46556
38565	4.250"	565	190290	6.385"	14062	4.600"	696380	Flat -3cc	9.9	9.5	9.1	1/16", 3/16"	46458
39565**	4.250"	565	190290	6.385"	14062	4.600"	697880*	Dome +43cc	14.9	14.0	13.2	.043", 3/16"	46558
38572	4.250"	572	190290	6.385"	14062	4.625"	696390	Flat -3cc	10.0	9.6	9.2	1/16", 3/16"	46459
39572	4.250"	572	190290	6.385"	14062	4.625"	697890*	Dome +43cc	15.1	14.1	13.3	.043", 3/16"	46559
39582**	4.375"	582	190320	6.535"	14066	4.600"	698280*	Dome +43cc	15.3	14.4	13.5	.043", 3/16"	46558
TALL DECK BLOCKS WITH CENTER COUNTERWEIGHTS													
28598	4.500"	598	190220	6.700"	14072	4.600"	698080	Flat -3cc	10.5	10.0	9.7	1/16", 3/16"	46458
29598	4.500"	598	190220	6.700"	14072	4.600"	697680*	Dome +43cc	15.7	14.7	13.9	.043", 3/16"	46558
38615	4.625"	615	190400	6.700"	14072	4.600"	698480	Flat -3cc	10.8	10.3	9.9	1/16", 3/16"	46458
39615	4.625"	615	190400	6.700"	14072	4.600"	698580*	Dome +43cc	16.2	15.1	14.2	.043", 3/16"	46558
28632	4.750"	632	190280	6.700"	14072	4.600"	698180	Flat -3cc	11.0	10.5	10.1	1/16", 3/16"	46458
29632	4.750"	632	190280	6.700"	14072	4.600"	697980*	Dome +43cc	16.6	15.5	14.6	.043", 3/16"	46558

**Note: These BB Chevy rotating assemblies listed above are factory balanced to within +/- 1% of bobweight. Order part number 04000-1 for precision balancing to within 5 grams

Add an "R" to the assembly part number to order the optional ARP 2000 rod bolt upgrade

Add an "H" to the assembly part number to order the optional "H" Series main bearings

Add an "X" to the assembly part number to order the optional "X" Series rod bearings with .001" extra clearance

Add an "HX" to the assembly part number to order the optional "HX" Series main bearings with .001" extra clearance

*Note: All Dome +43cc pistons are lateral gas ported
Dome fits Pro 1 and BB-3 heads @ 118cc with no additional modifications needed
Also fits Edelbrock Victor heads
Other applications or smaller combustion chambers must be checked

Bearing Chart

Clevite® "H" Series Rod Bearings	Clevite® "HX" Series Rod Bearings	Clevite® "P" Series Main Bearings	Clevite® "H" Series Main Bearings	Clevite® "HX" Series Main Bearings
30040	30040X	33040	33040H	33040HX

CRANKSHAFTS & ROTATING ASSEMBLIES

Chevrolet LS Crankshafts

- ▶ 4340 material forgings
- ▶ Multi-step heat treatment process and nitrided for added strength
- ▶ Stress relieved, shot-peened and 100% magnafluxed
- ▶ Micro polished large radius journals (narrowed bearings required)
- ▶ Gun drilled mains and lightened rod journals for weight reduction
- ▶ Counterweights fully profiled



Part No.	Design LW or SLW	Reluctor Wheel 24 or 58 Tooth	Stroke	Minimum Rod Length	Main Journal Diameter	Rod Journal Diameter	Bobweight (grams)	Total Weight (lbs.)
LIGHTWEIGHT								
193924	LW	24	3.622"	6.098"	2.559"	2.100"	1800	51-53
193958	LW	58	3.622"	6.098"	2.559"	2.100"	1800	51-53
190024	LW	24	4.000"	6.125"	2.559"	2.100"	1755	50-52
190024NB	LW	24	4.000"	6.125"	2.559"	2.100"	See Note*	50-52
190058	LW	58	4.000"	6.125"	2.559"	2.100"	1755	50-52
190058NB	LW	58	4.000"	6.125"	2.559"	2.100"	See Note*	50-52
192124	LW	24	4.000"	6.125"	2.559"	2.100"	1800	51-53
192158	LW	58	4.000"	6.125"	2.559"	2.100"	1800	51-53
190124	LW	24	4.100"	6.125"	2.559"	2.100"	1755	50-52
190124NB	LW	24	4.100"	6.125"	2.559"	2.100"	See Note*	50-52
190158	LW	58	4.100"	6.125"	2.559"	2.100"	1755	50-52
190158NB	LW	58	4.100"	6.125"	2.559"	2.100"	See Note*	50-52
194524	LW	24	4.100"	6.125"	2.559"	2.100"	1800	50-52
194558	LW	58	4.100"	6.125"	2.559"	2.100"	1800	50-52
LIGHTWEIGHT WITH LONG SNOOT (LS-7)								
192658	LW	58	4.000"	6.125"	2.559"	2.100"	1800	51-53
192758	LW	58	4.100"	6.125"	2.559"	2.100"	1800	51-53

Note: Manley crankshafts are not intended for use with highly boosted roots style cog belt superchargers

* These cranks are not balanced and have non-drilled counterweights

Precision Balancing Information

Part No.	Bobweight Modification
04004-1	Precision balancing the crankshaft from -200 to -71 grams from the published bobweight
04000-1	Precision balancing the crankshaft from -70 to +20 grams from the published bobweight
04005-1	Precision balancing the crankshaft from +21 to +80 grams from the published bobweight
04006-1	Precision balancing the crankshaft from +81 to +160 grams from the published bobweight

LS "Ready To Run" Rotating Assemblies

- ▶ Lightweight 4340 forged steel crankshaft
- ▶ 4340 Forged steel H-Beam connecting rods with 7/16" ARP 8740 cap screws or optional ARP 2000 cap screws
- ▶ 2618 Forged aluminum Platinum Series pistons with Premium Chrome Moly wrist pins
- ▶ Total Seal® piston rings & high performance Clevite® "H" Series rod bearings (narrowed) and "P" Series main bearings

Part No.	Stroke	CID	Crank P/N		Rod Length	Rod P/N	Bore Size	Piston P/N	Piston Type	Compression Ratio				Piston Ring Package	Piston Ring P/N
			Reluctor Wheel	Wheel						64cc	66cc	70cc	72cc		
28402	4.000"	402	190058	58 Tooth	6.125"	14051	4.005"	596205C	Dish -18cc	10.1	9.9	9.5	9.4	1.5mm, 3mm	46110
29402	4.000"	402	190058	58 Tooth	6.125"	14051	4.005"	592605C	Flat -4cc	11.7	11.4	10.9	10.7	1.5mm, 3mm	46110
28415	4.000"	415	190058	58 Tooth	6.125"	14051	4.070"	596270C	Dish -18cc	10.4	10.2	9.8	9.6	1.5mm, 3mm	46117
29415	4.000"	415	190058	58 Tooth	6.125"	14051	4.070"	592670C	Flat -4cc	12.1	11.8	11.3	11.1	1.5mm, 3mm	46117

Factory balanced to +/- 1% of bobweight

Add an "R" to the assembly part number to order the optional ARP 2000 rod bolt upgrade

CUSTOM ROTATING ASSEMBLIES

Chevrolet LS Rotating Assemblies

Ordering a Manley LS rotating assembly is as easy as 1-2-3.....

1. Choose your crankshaft part number based on stroke, weight, and reluctor wheel and then order the corresponding rod and main bearing part numbers shown
2. Choose your connecting rod part number
3. Choose your piston part number based on bore size and desired compression ratio along with the corresponding piston ring part number

Ordering all of the required components for your LS rotating assembly from Manley will result in extra \$ savings. Please contact your Manley representative for more details

Order P/N **04000-1** for precision balancing within 5 grams

CRANKS

- ▶ 4340 material forgings
- ▶ Multi-step heat treatment process and nitrided for added strength
- ▶ Stress relieved, shot-peened and 100% magnafluxed
- ▶ Micro polished large radius journals
- ▶ Available with either 24 or 58 tooth reluctor wheels
- ▶ Gun drilled mains and lightened rod journals for weight reduction
- ▶ Counterweights fully profiled

RODS

- ▶ Lightweight design 4340 material forgings
- ▶ Fully machined, heat treated, stress relieved, shot peened and 100% magnafluxed
- ▶ Big and small end bores are final honed to a tolerance of $\pm .0002''$
- ▶ Bend and twist is tightly controlled
- ▶ Weight matched to +/- 1.5 grams
- ▶ H-Beam comes standard with low profile 7/16" ARP 8740 bolts providing additional block and oil pan clearance (affix an R suffix for ARP 2000 bolt upgrade)
- ▶ H-Tuff comes standard with low profile 7/16" ARP 2000 bolts
- ▶ I-Beam comes standard with 7/16" ARP 2000 bolts (affix an R6 suffix for ARP 625+ bolt upgrade)

PISTONS

- ▶ High strength 2618 alloy forgings
- ▶ Exacting ring groove squareness to cylinder wall provides maximum horsepower.
- ▶ Offset wrist pin design
- ▶ Premium Chrome Moly pin included with Standard Series
- ▶ 9310 Alloy pin included with Extreme Duty Series
- ▶ Moly coated skirts

RINGS

- ▶ 1.5 x 1.5 x 3mm Total Seal (moly in-lay tops standard)
- ▶ Premium steel top rings are optional (affix ST suffix)
- ▶ Total Seal Gapless® steel top ring sets also available (affix GT suffix)

BEARINGS

- ▶ Premium Clevite® "H" Series narrowed rod bearings and "P" Series or "H" Series main bearings

Small Block Chevrolet LS Series

Lightweight 1800gm. Bobweight 3.622" Stroke Cranks

Crank P/N Reluctor Wheel	Standard Part No.	Extreme Duty Part No.	Piston Description	Ring Part No.	Compression Ratio				Balance Req. (Y/N)		
					64cc	66cc	70cc	72cc	14051-8	15051R-8	14559-8
193924 24 Tooth or 193958 58 Tooth	592107C-8	592107CE-8	3.905/-4cc F/T	46107-8	10.2	10.0	9.5	9.3	Y	Y	Y
	592110C-8	592110CE-8	3.910/-4cc F/T	46107-8	10.3	10.1	9.7	9.5	Y	Y	Y
	592501C-8	592501CE-8	4.001/-4cc F/T	46110-8	10.6	10.4	9.8	9.6	N*	Y	Y
	592505C-8	592505CE-8	4.005/-4cc F/T	46110-8	10.6	10.4	9.8	9.6	N*	Y	Y
	592510C-8	592510CE-8	4.010/-4cc F/T	46111-8	10.7	10.5	9.9	9.7	N*	Y	Y
	592530C-8	592530CE-8	4.030/-4cc F/T	46113-8	10.8	10.6	10.1	9.9	N*	Y	Y
6.125" Rod P/N Description	592565C-8	592565CE-8	4.065/-4cc F/T	46116-8	11.0	10.7	10.2	10.0	N*	Y	Y
	592570C-8	592570CE-8	4.070/-4cc F/T	46117-8	11.1	10.8	10.3	10.1	N*	Y	Y
	592575C-8	592575CE-8	4.075/-4cc F/T	46117-8	11.2	10.9	10.4	10.2	N*	Y	Y
	592580C-8	592580CE-8	4.080/-4cc F/T	46118-8	11.3	11.0	10.5	10.3	N*	Y	Y
14051-8 H-Beam or 15051R-8 H-Tuff or 14559-8 SW I-Beam	596107C-8	596107CE-8	3.905/-10cc Dish	46107-8	9.6	9.4	9.0	8.8	Y	Y	Y
	596105C-8	596105CE-8	4.005/-10cc Dish	46110-8	10.0	9.8	9.4	9.2	N*	Y	Y
	596110C-8	596110CE-8	4.010/-10cc Dish	46111-8	10.1	9.9	9.5	9.3	N*	Y	Y
	596130C-8	596130CE-8	4.030/-10cc Dish	46113-8	10.2	9.9	9.5	9.3	N*	Y	Y
	596165C-8	596165CE-8	4.065/-10cc Dish	46116-8	10.3	10.1	9.7	9.5	N*	Y	Y
	596170C-8	596170CE-8	4.070/-10cc Dish	46117-8	10.3	10.1	9.7	9.5	N*	Y	Y
Bearing P/N Description	596175C-8	596175CE-8	4.075/-10cc Dish	46117-8	10.4	10.2	9.8	9.6	N*	Y	Y
	596180C-8	596180CE-8	4.080/-10cc Dish	46118-8	10.5	10.3	9.9	9.6	N*	Y	Y
	596907C-8	596907CE-8	3.905/-18cc Dish	46107-8	8.8	8.7	8.3	8.2	Y	Y	Y
	596905C-8	596905CE-8	4.005/-18cc Dish	46110-8	9.2	9.0	8.7	8.5	Y	Y	Y
30010 or 30010X* Rod & 33030 or 33030H Main	596965C-8	596965CE-8	4.065/-18cc Dish	46116-8	9.5	9.3	9.0	8.8	N*	Y	Y
	596970C-8	596970CE-8	4.070/-18cc Dish	46117-8	9.6	9.4	9.1	8.9	N*	Y	Y
	596975C-8	596975CE-8	4.075/-18cc Dish	46117-8	9.7	9.5	9.2	9.0	N*	Y	Y
	596980C-8	596980CE-8	4.080/-18cc Dish	46118-8	9.8	9.6	9.3	9.1	N*	Y	Y

*N = Factory balanced to +/- 1% of bobweight

Order part number **04000-1** for precision balancing to within 5 grams

Note: "SW" = "Standard Weight" design rod

* HX Series rod bearings with .001" extra clearance

Note: New part numbers are **BOLD & ITALICIZED**

CUSTOM ROTATING ASSEMBLIES

Small Block Chevrolet LS Series

Lightweight 1755gm. Bobweight 4.000" Stroke Cranks

Crank P/N Reluctor Wheel	Standard Part No.	Extreme Duty Part No.	Piston Description	Ring Part No.	Compression Ratio				Balance Req. (Y/N)		
					64cc	66cc	70cc	72cc	14051-8	15051R-8	14559-8
190024 24 Tooth or 190058 58 Tooth	592207C-8	592207CE-8	3.905/-4cc F/T	46107-8	11.2	11.0	10.4	10.2	Y	Y	Y
	592605C-8	592605CE-8	4.005/-4cc F/T	46110-8	11.7	11.4	10.9	10.7	N*	Y	Y
	592610C-8	592610CE-8	4.010/-4cc F/T	46111-8	11.7	11.5	11.0	10.7	N*	Y	Y
	592630C-8	592630CE-8	4.030/-4cc F/T	46113-8	11.9	11.6	11.1	10.9	N*	Y	Y
	592665C-8	592665CE-8	4.065/-4cc F/T	46116-8	12.1	11.8	11.3	11.1	N*	Y	Y
	592670C-8	592670CE-8	4.070/-4cc F/T	46117-8	12.1	11.8	11.3	11.1	N*	Y	Y
	592675C-8	592675CE-8	4.075/-4cc F/T	46117-8	12.2	11.9	11.4	11.2	N*	Y	Y
	592680C-8	592680CE-8	4.080/-4cc F/T	46118-8	12.3	12.0	11.5	11.3	N*	Y	Y
6.125" Rod P/N Description	592701C-8	592701CE-8	4.001/-10cc Dish	46110-8	10.8	10.6	10.1	9.9	N*	Y	Y
	592705C-8	592705CE-8	4.005/-10cc Dish	46110-8	10.9	10.7	10.2	10.0	N*	Y	Y
14051-8 H-Beam or 15051R-8 H-Tuff or 14559-8 SW I-Beam	592730C-8	592730CE-8	4.030/-10cc Dish	46113-8	11.1	10.8	10.3	10.1	N*	Y	Y
	592765C-8	592765CE-8	4.065/-10cc Dish	46116-8	11.3	11.0	10.5	10.3	N*	Y	Y
	592770C-8	592770CE-8	4.070/-10cc Dish	46117-8	11.4	11.1	10.6	10.4	N*	Y	Y
	592775C-8	592775CE-8	4.075/-10cc Dish	46117-8	11.5	11.2	10.7	10.5	N*	Y	Y
	592780C-8	592780CE-8	4.080/-10cc Dish	46118-8	11.6	11.3	10.8	10.6	N*	Y	Y
	596207C-8	596207CE-8	3.905/-18cc Dish	46107-8	9.7	9.5	9.2	9.0	Y	Y	Y
	596205C-8	596205CE-8	4.005/-18cc Dish	46110-8	10.1	9.9	9.5	9.4	N*	Y	Y
	596230C-8	596230CE-8	4.030/-18cc Dish	46113-8	10.2	10.0	9.6	9.5	N*	Y	Y
Bearing P/N Description	596265C-8	596265CE-8	4.065/-18cc Dish	46116-8	10.4	10.2	9.8	9.6	N*	Y	Y
	596270C-8	596270CE-8	4.070/-18cc Dish	46117-8	10.4	10.2	9.8	9.6	N*	Y	Y
30010 or 30010X* Rod & 33030 or 33030H Main	596275C-8	596275CE-8	4.075/-18cc Dish	46117-8	10.5	10.3	9.9	9.7	N*	Y	Y
	596280C-8	596280CE-8	4.080/-18cc Dish	46118-8	10.6	10.4	10.0	9.8	N*	Y	Y
	592807C-8	592807CE-8	3.905/-29cc Dish	46107-8	8.7	8.5	8.2	8.1	Y	Y	Y
	592801C-8	592801CE-8	4.001/-29cc Dish	46110-8	9.0	8.8	8.5	8.4	N*	Y	Y
	592805C-8	592805CE-8	4.005/-29cc Dish	46110-8	9.1	8.9	8.6	8.5	N*	Y	Y
	592830C-8	592830CE-8	4.030/-29cc Dish	46113-8	9.2	9.0	8.7	8.6	N*	Y	Y
	592865C-8	592865CE-8	4.065/-29cc Dish	46116-8	9.3	9.1	8.8	8.7	N*	Y	Y
	592870C-8	592870CE-8	4.070/-29cc Dish	46117-8	9.4	9.2	8.9	8.8	N*	Y	Y
	592875C-8	592875CE-8	4.075/-29cc Dish	46117-8	9.5	9.3	9.0	8.9	N*	Y	Y
	592880C-8	592880CE-8	4.080/-29cc Dish	46118-8	9.6	9.4	9.1	9.0	N*	Y	Y

Small Block Chevrolet LS Series

Lightweight 1800gm. Bobweight 4.000" Stroke Cranks

Crank P/N Reluctor Wheel	Standard Part No.	Extreme Duty Part No.	Piston Description	Ring Part No.	Compression Ratio				Balance Req. (Y/N)		
					64cc	66cc	70cc	72cc	14051-8	15051R-8	14559-8
192124 24 Tooth or 192158 58 Tooth	592300C-8	592300CE-8	4.125/-5cc F/T	46360-8	12.3	12.0	11.5	11.3	N*	Y	Y
	592305C-8	592305CE-8	4.130/-5cc F/T	46361-8	12.4	12.1	11.6	11.4	N*	Y	Y
	592310C-8	592310CE-8	4.135/-5cc F/T	46362-8	12.5	12.2	11.7	11.5	N*	Y	Y
6.125" Rod P/N Description	592400C-8	592400CE-8	4.125/-11cc Dish	46360-8	11.5	11.3	10.8	10.6	N*	Y	Y
	592405C-8	592405CE-8	4.130/-11cc Dish	46361-8	11.6	11.4	10.9	10.5	N*	Y	Y
14051-8 H-Beam or 15051R-8 H-Tuff or 14559-8 SW I-Beam	592410C-8	592410CE-8	4.135/-11cc Dish	46362-8	11.7	11.5	11.0	10.6	N*	Y	Y
	596300C-8	596300CE-8	4.125/-18cc Dish	46360-8	10.6	10.4	10.0	9.8	N*	Y	Y
	596305C-8	596305CE-8	4.130/-18cc Dish	46361-8	10.6	10.4	10.0	9.9	N*	Y	Y
Bearing P/N Description	596310C-8	596310CE-8	4.135/-18cc Dish	46362-8	10.7	10.5	10.1	10.0	N*	Y	Y
	592900C-8	592900CE-8	4.125/-29cc Dish	46360-8	9.6	9.4	9.1	9.0	N*	Y	Y
30010 or 30010X* Rod 33030 or 33030H Main	592905C-8	592905CE-8	4.130/-29cc Dish	46361-8	9.7	9.5	9.2	9.1	N*	Y	Y
	592910C-8	592910CE-8	4.135/-29cc Dish	46362-8	9.8	9.6	9.3	9.2	N*	Y	Y

*N = Factory balanced to +/- 1% of bobweight

Order part number 04000-1 for precision balancing to within 5 grams

Note: "SW" = "Standard Weight" design rod

* HX Series rod bearings with .001" extra clearance

CUSTOM ROTATING ASSEMBLIES

Small Block Chevrolet LS Series

Lightweight 1755gm. Bobweight 4.100" Stroke Cranks

Crank P/N Reluctor Wheel	Standard Part No.	Extreme Duty Part No.	Piston Description	Ring Part No.	Compression Ratio				Balance Req. (Y/N)		
					64cc	66cc	70cc	72cc	14051-8	15051R-8	14559-8
190124 24 Tooth or 190158 58 Tooth	596505C-8	596505CE-8	4.005/-10cc Dish	46110-8	11.1	10.9	10.5	10.3	N*	Y	Y
	596565C-8	596565CE-8	4.065/-10cc Dish	46116-8	11.4	11.2	10.7	10.5	N*	Y	Y
	596570C-8	596570CE-8	4.070/-10cc Dish	46117-8	11.5	11.3	10.8	10.6	N*	Y	Y
	596575C-8	596575CE-8	4.075/-10cc Dish	46117-8	11.6	11.4	10.9	10.7	N*	Y	Y
	596580C-8	596580CE-8	4.080/-10cc Dish	46118-8	11.7	11.5	11.0	10.8	N*	Y	Y
6.125" Rod P/N Description	596600C-8	596600CE-8	4.125/-11cc Dish	46360-8	11.6	11.4	10.9	10.7	Y	Y	Y
	596605C-8	596605CE-8	4.130/-11cc Dish	46361-8	11.7	11.5	11.0	10.8	Y	Y	Y
	596610C-8	596610CE-8	4.135/-11cc Dish	46362-8	11.8	11.6	11.1	10.9	Y	Y	Y
14051-8 H-Beam or 15051R-8 H-Tuff or 14559-8 SW I-Beam	596005C-8	596005CE-8	4.005/-20cc Dish	46110-8	10.1	9.9	9.6	9.4	N*	Y	Y
	596065C-8	596065CE-8	4.065/-20cc Dish	46116-8	10.4	10.2	9.8	9.6	N*	Y	Y
	596070C-8	596070CE-8	4.070/-20cc Dish	46117-8	10.4	10.2	9.8	9.7	N*	Y	Y
	596075C-8	596075CE-8	4.075/-20cc Dish	46117-8	10.5	10.3	9.9	9.8	N*	Y	Y
	596080C-8	596080CE-8	4.080/-20cc Dish	46118-8	10.6	10.4	10.0	9.9	N*	Y	Y
Bearing P/N Description	596400C-8	596400CE-8	4.125/-20cc Dish	46360-8	10.6	10.4	10.1	9.9	Y	Y	Y
	596405C-8	596405CE-8	4.130/-20cc Dish	46361-8	10.7	10.5	10.1	9.9	Y	Y	Y
	596410C-8	596410CE-8	4.135/-20cc Dish	46362-8	10.8	10.6	10.2	10.0	Y	Y	Y
30010 or 30010X* Rod & 33030 or 33030H Main	596705C-8	596705CE-8	4.005/-31cc Dish	46110-8	9.1	9.0	8.7	8.5	N*	Y	Y
	596765C-8	596765CE-8	4.065/-31cc Dish	46116-8	9.3	9.2	8.9	8.7	N*	Y	Y
	596770C-8	596770CE-8	4.070/-31cc Dish	46117-8	9.4	9.3	9.0	8.8	N*	Y	Y
	596775C-8	596775CE-8	4.075/-31cc Dish	46117-8	9.5	9.4	9.1	8.9	N*	Y	Y
	596780C-8	596780CE-8	4.080/-31cc Dish	46118-8	9.6	9.5	9.2	9.0	N*	Y	Y
Bearing P/N Description	596800C-8	596800CE-8	4.125/-31cc Dish	46360-8	9.6	9.4	9.1	9.0	Y	Y	Y
	596805C-8	596805CE-8	4.130/-31cc Dish	46361-8	9.7	9.5	9.2	9.1	Y	Y	Y
	596810C-8	596810CE-8	4.135/-31cc Dish	46362-8	9.8	9.6	9.3	9.2	Y	Y	Y

Small Block Chevrolet LS Series

Lightweight 1800gm. Bobweight 4.100" Stroke Cranks

Crank P/N Reluctor Wheel	Standard Part No.	Extreme Duty Part No.	Piston Description	Ring Part No.	Compression Ratio				Balance Req. (Y/N)		
					64cc	66cc	70cc	72cc	14051-8	15051R-8	14559-8
194524 24 Tooth or 194558 58 Tooth	596600C-8	596600CE-8	4.125/-11cc Dish	46360-8	11.6	11.4	10.9	10.7	N*	Y	Y
	596605C-8	596605CE-8	4.130/-11cc Dish	46361-8	11.7	11.5	11.0	10.8	N*	Y	Y
	596610C-8	596610CE-8	4.135/-11cc Dish	46362-8	11.8	11.6	11.5	10.9	N*	Y	Y
6.125" Rod P/N Description	596400C-8	596400CE-8	4.125/-20cc Dish	46360-8	10.6	10.4	10.1	9.9	N*	Y	Y
14051-8 H-Beam or 15051R-8 H-Tuff or 14559-8 SW I-Beam	596405C-8	596405CE-8	4.130/-20cc Dish	46361-8	10.7	10.5	10.1	9.9	N*	Y	Y
	596410C-8	596410CE-8	4.135/-20cc Dish	46362-8	10.8	10.6	10.2	10.0	N*	Y	Y
Bearing P/N Description	596800C-8	596800CE-8	4.125/-31cc Dish	46360-8	9.6	9.4	9.1	9.0	N*	Y	Y
	596805C-8	596805CE-8	4.130/-31cc Dish	46361-8	9.7	9.5	9.2	9.1	N*	Y	Y
	596810C-8	596810CE-8	4.135/-31cc Dish	46362-8	9.8	9.6	9.3	9.2	N*	Y	Y
30010 or 30010X* Rod 33030 or 33030H Main											

*N = Factory balanced to +/- 1% of bobweight

Order part number 04000-1 for precision balancing to within 5 grams

Note: "SW" = "Standard Weight" design rod

* HX Series rod bearings with .001" extra clearance

CUSTOM ROTATING ASSEMBLIES

Small Block Chevrolet LS-7 (Long Snout)

Lightweight 1800gm. Bobweight 4.000" Stroke Cranks

Crank P/N Reluctor Wheel	Standard Part No.	Extreme Duty Part No.	Piston Description	Ring Part No.	Compression Ratio				Balance Req. (Y/N)		
					64cc	66cc	70cc	72cc	14051-8	15051R-8	14559-8
192658 58 Tooth	592300C-8	592300CE-8	4.125/-5cc F/T	46360-8	12.3	12.0	11.5	11.3	N*	Y	Y
	592305C-8	592305CE-8	4.130/-5cc F/T	46361-8	12.4	12.1	11.6	11.4	N*	Y	Y
	592310C-8	592310CE-8	4.135/-5cc F/T	46362-8	12.5	12.2	11.7	11.5	N*	Y	Y
6.125" Rod P/N Description	592400C-8	592400CE-8	4.125/-11cc Dish	46360-8	11.5	11.3	10.8	10.6	N*	Y	Y
	592405C-8	592405CE-8	4.130/-11cc Dish	46361-8	11.6	11.4	10.9	10.5	N*	Y	Y
	592410C-8	592410CE-8	4.135/-11cc Dish	46362-8	11.7	11.5	11.0	10.6	N*	Y	Y
14051-8 H-Beam or 15051R-8 H-Tuff or 14559-8 SW I-Beam	596300C-8	596300CE-8	4.125/-18cc Dish	46360-8	10.6	10.4	10.0	9.8	N*	Y	Y
	596305C-8	596305CE-8	4.130/-18cc Dish	46361-8	10.6	10.4	10.0	9.9	N*	Y	Y
	596310C-8	596310CE-8	4.135/-18cc Dish	46362-8	10.7	10.5	10.1	10.0	N*	Y	Y
Bearing P/N Description	592900C-8	592900CE-8	4.125/-29cc Dish	46360-8	9.6	9.4	9.1	9.0	N*	Y	Y
	592905C-8	592905CE-8	4.130/-29cc Dish	46361-8	9.7	9.5	9.2	9.1	N*	Y	Y
	592910C-8	592910CE-8	4.135/-29cc Dish	46362-8	9.8	9.6	9.3	9.2	N*	Y	Y
30010 or 30010X* Rod 33030 or 33030H Main											

Small Block Chevrolet LS-7 (Long Snout)

Lightweight 1800gm. Bobweight 4.100" Stroke Cranks

Crank P/N Reluctor Wheel	Standard Part No.	Extreme Duty Part No.	Piston Description	Ring Part No.	Compression Ratio				Balance Req. (Y/N)		
					64cc	66cc	70cc	72cc	14051-8	15051R-8	14559-8
192758 58 Tooth	596600C-8	596600CE-8	4.125/-11cc Dish	46360-8	11.6	11.4	10.9	10.7	N*	Y	Y
	596605C-8	596605CE-8	4.130/-11cc Dish	46361-8	11.7	11.5	11.0	10.8	N*	Y	Y
	596610C-8	596610CE-8	4.135/-11cc Dish	46362-8	11.8	11.6	11.1	10.9	N*	Y	Y
14051-8 H-Beam or 15051R-8 H-Tuff or 14559-8 SW I-Beam	596400C-8	596400CE-8	4.125/-20cc Dish	46360-8	10.6	10.4	10.1	9.9	N*	Y	Y
	596405C-8	596405CE-8	4.130/-20cc Dish	46361-8	10.7	10.5	10.1	9.9	N*	Y	Y
	596410C-8	596410CE-8	4.135/-20cc Dish	46362-8	10.8	10.6	10.2	10.0	N*	Y	Y
Bearing P/N Description	596800C-8	596800CE-8	4.125/-31cc Dish	46360-8	9.6	9.4	9.1	9.0	N*	Y	Y
	596805C-8	596805CE-8	4.130/-31cc Dish	46361-8	9.7	9.5	9.2	9.1	N*	Y	Y
	596810C-8	596810CE-8	4.135/-31cc Dish	46362-8	9.8	9.6	9.3	9.2	N*	Y	Y
30010 or 30010X* Rod 33030 or 33030H Main											

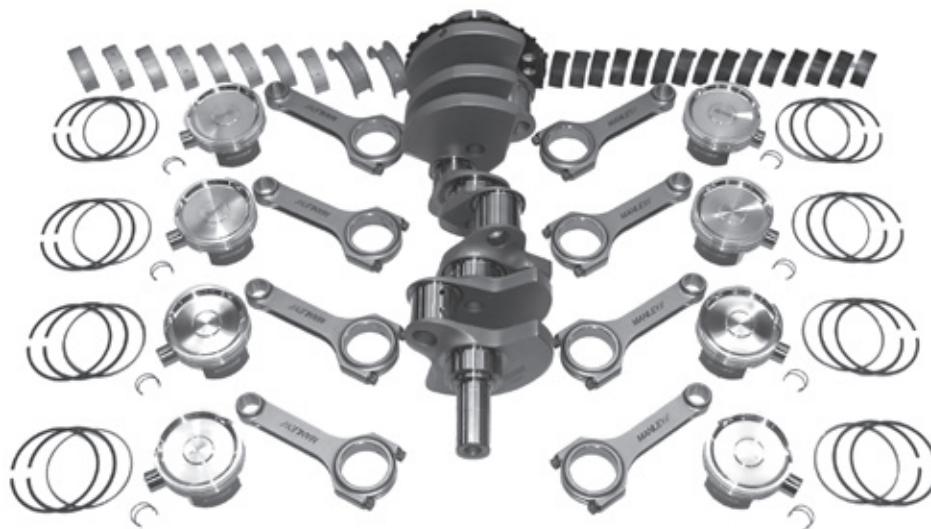

*N = Factory balanced to +/- 1% of bobweight
 Order part number 04000-1 for precision balancing to within 5 grams
 Note: "SW" = "Standard Weight" design rod
 * HX Series rod bearings with .001" extra clearance

CUSTOM ROTATING ASSEMBLIES

Chevrolet 5.3L LS / L83 Rotating Assemblies

Small Block Chevrolet 5.3L LS Gen III/IV

Lightweight 1800gm. Bobweight 3.622" Stroke Cranks

Crank P/N Reluctor Wheel	Standard Part No.	Extreme Duty Part No.	Piston Description	Ring Part No.	Compression Ratio				Balance Req. (Y/N)		
					58cc	62cc	66cc	70cc	14051-8	15051R-8	14559-8
193924 24 Tooth or 193958 58 Tooth	561005C-8	561005CE-8	3.785/-2cc Flat Top	46500ST-8	10.50	9.99	9.53	9.11	Y	Y	Y
	561010C-8	561010CE-8	3.790/-2cc Flat Top	46510ST-8	10.55	10.03	9.57	9.15	Y	Y	Y
	561020C-8	561020CE-8	3.800/-2cc Flat Top	46520ST-8	10.60	10.08	9.62	9.20	Y	Y	Y
6.125" Rod P/N Description		Bearing P/N Description									
14051-8 H-Beam or 15051R-8 H-Tuff or 14559-8 SW I-Beam		30010 or 30010X* Rod & 33030 or 33030H Main									

Lightweight 1800gm. Bobweight 4.000" Stroke Cranks

Crank P/N Reluctor Wheel	Standard Part No.	Extreme Duty Part No.	Piston Description	Ring Part No.	Compression Ratio				Balance Req. (Y/N)		
					58cc	62cc	66cc	70cc	14051-8	15051R-8	14559-8
192124 24 Tooth or 192158 58 Tooth	561105C-8	561105CE-8	3.785/-7cc Dish	46500ST-8	10.82	10.32	9.87	9.46	Y	Y	Y
	561110C-8	561110CE-8	3.790/-7cc Dish	46510ST-8	10.87	10.37	9.92	9.51	Y	Y	Y
	561120C-8	561120CE-8	3.800/-7cc Dish	46520ST-8	10.92	10.42	9.96	9.55	Y	Y	Y
6.125" Rod P/N Description		Bearing P/N Description									
14051-8 H-Beam or 15051R-8 H-Tuff or 14559-8 SW I-Beam		30010 or 30010X* Rod & 33030 or 33030H Main									

Small Block Chevrolet 5.3L L83 Gen V Direct Injected

Lightweight 1850gm. Bobweight 3.622" Stroke Cranks

Crank P/N Reluctor Wheel	Standard Part No.	Extreme Duty Part No.	Piston Description	Ring Part No.	Compression Ratio	Balance Req. (Y/N)					
					60cc	14051-8	15051R-8	14559-8			
194158 194358 (Long Snout) 58 Tooth	561200C-8	561200CE-8	3.780/-2cc Dome	46500ST-8	10.26	Y	Y	Y			
	561210C-8	561210CE-8	3.790/-2cc Dome	46510ST-8	10.31	Y	Y	Y			
	561220C-8	561220CE-8	3.800/-2cc Dome	46520ST-8	10.36	Y	Y	Y			
6.125" Rod P/N Description		Bearing P/N Description									
14051-8 H-Beam or 15051R-8 H-Tuff or 14559-8 SW I-Beam		30010 or 30010X* Rod 33110H Main									

Lightweight 1820gm. Bobweight 4.000" Stroke Cranks

Crank P/N Reluctor Wheel	Standard Part No.	Extreme Duty Part No.	Piston Description	Ring Part No.	Compression Ratio	Balance Req. (Y/N)					
					60cc	14051-8	15051R-8	14559-8			
194258 194458 (Long Snout) 58 Tooth	561300C-8	561300CE-8	3.780/-10cc Dish	46500ST-8	10.20	Y	Y	Y			
	561310C-8	561310CE-8	3.790/-10cc Dish	46510ST-8	10.25	Y	Y	Y			
	561320C-8	561320CE-8	3.800/-10cc Dish	46520ST-8	10.30	Y	Y	Y			
6.125" Rod P/N Description		Bearing P/N Description									
14051-8 H-Beam or 15051R-8 H-Tuff or 14559-8 SW I-Beam		30010 or 30010X* Rod 33110H Main									

Order part number 04000-1 for precision balancing to within 5 grams

Note: "SW" = "Standard Weight" design rod

* HX Series rod bearings with .001" extra clearance

Chevrolet LT1/LT4 Crankshafts

Direct Injected LT1/LT4 4340 Forged Crankshafts

Manley Performance "PRO SERIES" crankshafts designed for the Small Block direct injected LT1/LT4 engine... Manufactured from a premium 4340 steel forging, these cranks feature a stock 3.622" stroke or an increased 4.000" stroke which can turn your 6.2L into 6.8-7.0L depending on your bore. All crankshafts are shipped with a 58 tooth reluctor wheel installed.

- ▶ 4340 material forgings
- ▶ Multi-step heat treatment process and nitrided for added strength
- ▶ Stress relieved, shot-peened and 100% magnafluxed
- ▶ Micro polished large radius journals (narrowed rod bearings required)
- ▶ Gun drilled mains and lightened rod journals for weight reduction
- ▶ Counterweights fully profiled

Part No.	Stroke	Minimum Rod Length	Main Journal Diameter	Rod Journal Diameter	Bobweight (grams)	Total Weight (lbs.)
LIGHTWEIGHT						
194158	3.622"	6.098"	2.559"	2.100"	1850	51-53
194258	4.000"	6.125"	2.559"	2.100"	1820	51-53
LIGHTWEIGHT WITH LONG SNOOT (Dry Sump Oiling Systems)						
194358	3.622"	6.098"	2.559"	2.100"	1850	51-53
194458	4.000"	6.125"	2.559"	2.100"	1820	51-53

The stock timing crank gear may need to be chamfered to clear the larger radius on the snout of the crankshaft

Note: Manley crankshafts are not intended for use with highly boosted roots style cog belt superchargers

Precision Balancing Information

Part No.	Bobweight Modification
04004-1	Precision balancing the crankshaft from -200 to -71 grams from the published bobweight
04000-1	Precision balancing the crankshaft from -70 to +20 grams from the published bobweight
04005-1	Precision balancing the crankshaft from +21 to +80 grams from the published bobweight
04006-1	Precision balancing the crankshaft from +81 to +160 grams from the published bobweight



Create your own "Bullet-Proof" Chevy LT1/LT4 Rotating Assemblies with Manley H-Beam or Pro Series I-Beam Connecting Rods and Manley Platinum Series Pistons on Page 177.

CUSTOM ROTATING ASSEMBLIES

Chevrolet LT1/LT4 Rotating Assemblies

Ordering a Manley LT1/LT4 rotating assembly is as easy as 1-2-3...

1. Choose your crankshaft part number based on stroke and then order the corresponding rod and main bearing part numbers shown
2. Choose your connecting rod part number
3. Choose your piston part number based on bore size and desired compression ratio along with the corresponding piston ring part number

Ordering all of the required components for your LT1/LT4 rotating assembly from Manley will result in extra \$ savings. Please contact your Manley representative for more details.

Order part number **04000-1** for precision balancing to within 5 grams

CRANKS

- ▶ Lightweight 4340 material forgings
- ▶ Multi-step heat treatment process and nitrided for added strength
- ▶ Stress relieved, shot-peened and 100% magnafluxed
- ▶ Micro polished large radius journals
- ▶ Gun drilled mains and lightened rod journals for weight reduction
- ▶ Counterweights fully profiled

RODS

- ▶ Lightweight design 4340 material forgings
- ▶ Fully machined, heat treated, stress relieved, shot peened and 100% magnafluxed
- ▶ Big and small end bores are final honed to a tolerance of $\pm .0002"$
- ▶ Bend and twist is tightly controlled
- ▶ Weight matched to +/- 1.5 grams
- ▶ H-Beam comes standard with low profile 7/16" ARP 8740 bolts providing additional block and oil pan clearance (affix an R suffix for ARP 2000 bolt upgrade)
- ▶ H-Tuff comes standard with low profile 7/16" ARP 2000 bolts
- ▶ I-Beam comes standard with 7/16" ARP 2000 bolts (affix an R6 suffix for ARP 625+ bolt upgrade)

PISTONS

- ▶ High strength 2618 alloy forgings
- ▶ Exacting ring groove squareness to cylinder wall provides maximum horsepower.
- ▶ Offset wrist pin design
- ▶ Premium Chrome Moly pin included with Standard Series
- ▶ 9310 Alloy pin included with Extreme Duty Series
- ▶ Moly coated skirts

RINGS

- ▶ 1.2 x 1.2 x 3mm
- ▶ Premium steel top rings are optional (affix ST suffix)

BEARINGS

- ▶ Premium Clevite® "H" Series narrowed rod bearings and "H" Series main bearings

Small Block Chevrolet Direct Injected LT1/LT4 Lightweight 1850gm. Bobweight 3.622" Stroke Cranks

Crank P/N Reluctor Wheel	Standard Part No.	Extreme Duty Part No.	Piston Description	Ring Part No.	Comp. Ratio 60cc	Balance Req. (Y/N)		
						14051-8	15051R-8	14559-8
194158 194358 (Long Snout) 58 Tooth	560065C-8	560065CE-8	4.065/-2cc Dome	46016-8	11.7	N*	Y	Y
	560070C-8	560070CE-8	4.070/-2cc Dome	46017-8	11.7	N*	Y	Y
	560075C-8	560075CE-8	4.075/-2cc Dome	46017-8	11.8	N*	Y	Y
	560080C-8	560080CE-8	4.080/-2cc Dome	46018-8	11.8	N*	Y	Y
6.125" Rod P/N Description	560165C-8	560165CE-8	4.065/-12cc Dish	46016-8	10.5	N*	Y	Y
	560170C-8	560170CE-8	4.070/-12cc Dish	46017-8	10.5	N*	Y	Y
	560175C-8	560175CE-8	4.075/-12cc Dish	46017-8	10.6	N*	Y	Y
	560180C-8	560180CE-8	4.080/-12cc Dish	46018-8	10.6	N*	Y	Y
	14051-8 H-Beam or 15051R-8 H-Tuff or 14559-8 SW I-Beam							
Bearing P/N Description								
30010 or 30010X* Rod 33110H Main								

Lightweight 1820gm. Bobweight 4.000" Stroke Cranks

Crank P/N Reluctor Wheel	Standard Part No.	Extreme Duty Part No.	Piston Description	Ring Part No.	Comp. Ratio 60cc	Balance Req. (Y/N)		
						14051-8	15051R-8	14559-8
194258 194458 (Long Snout) 58 Tooth	560265C-8	560265CE-8	4.065/-10cc Dish	46016-8	11.7	N*	Y	Y
	560270C-8	560270CE-8	4.070/-10cc Dish	46017-8	11.7	N*	Y	Y
	560275C-8	560275CE-8	4.075/-10cc Dish	46017-8	11.8	N*	Y	Y
	560280C-8	560280CE-8	4.080/-10cc Dish	46018-8	11.8	N*	Y	Y
	560300C-8	560300CE-8	4.125/-10cc Dish	46060-8	12.0	N*	Y	Y
6.125" Rod P/N Description	560305C-8	560305CE-8	4.130/-10cc Dish	46061-8	12.0	N*	Y	Y
	560310C-8	560310CE-8	4.135/-10cc Dish	46062-8	12.1	N*	Y	Y
	560465C-8	560465CE-8	4.065/-20cc Dish	46016-8	10.5	N*	Y	Y
	560470C-8	560470CE-8	4.070/-20cc Dish	46017-8	10.5	N*	Y	Y
	560475C-8	560475CE-8	4.075/-20cc Dish	46017-8	10.6	N*	Y	Y
	560480C-8	560480CE-8	4.080/-20cc Dish	46018-8	10.6	N*	Y	Y
14051-8 H-Beam or 15051R-8 H-Tuff or 14559-8 SW I-Beam	560500C-8	560500CE-8	4.125/-20cc Dish	46060-8	10.8	N*	Y	Y
	560505C-8	560505CE-8	4.130/-20cc Dish	46061-8	10.8	N*	Y	Y
	560510C-8	560510CE-8	4.135/-20cc Dish	46062-8	10.9	N*	Y	Y
Bearing P/N Description								
30010 or 30010X* Rod 33110H Main								

*N = Factory balanced to +/- 1% of bobweight

Order part number **04000-1** for precision balancing to within 5 grams

Note: "SW" = "Standard Weight" design rod

* HX Series rod bearings with .001" extra clearance

Chrysler 5.7L/6.1L/6.4L Hemi

4340 Forged Crankshafts

Manley Performance "PRO SERIES" stroker crankshaft designed for the small block HEMI engine... Manufactured from a premium 4340 steel forging, these cranks feature a 4.050" stroke which can turn your 5.7L into a 392 c.i. engine and your 6.1L/6.4L into a 426 c.i. engine. The Manley 4.050" stroke HEMI crankshaft features small block Chevy small journal (2.000") crank pin diameters and widths. This provides taller "side walls" on the crankshaft rod journals for better oil control and reduced windage. The counterweights are profiled for 6.125" length connecting rods. All crankshafts are shipped with either a 32 tooth or 58 tooth reluctor wheel installed.

- ▶ 4340 material forging
- ▶ Multi-step heat treatment process and nitrided for added strength
- ▶ Stress relieved, shot-peened and 100% magnafluxed
- ▶ Micro polished large radius journals (narrowed rod bearings required)
- ▶ Dual keyed post for supercharger drive pulleys
- ▶ Gun drilled mains and lightened rod journals for weight reduction
- ▶ Counterweights fully profiled



Part No.	Application	Reluctor Wheel	Stroke	Bobweight (grams)	Total Weight (lbs.)
191832	5.7L Up to 2008 6.1L	32	4.050"	1730	49-51
191832NB	5.7L Up to 2008 6.1L	32	4.050"	See Note**	49-51
191858*	5.7L 2009-2012 6.4L 2011-2012	58	4.050"	1730	49-51
191858NB*	5.7L 2009-2012 6.4L 2011-2012	58	4.050"	See Note**	49-51
191958*	5.7L/6.4L 2013 - Up	58	4.050"	1730	49-51
191958NB*	5.7L/6.4L 2013 - Up	58	4.050"	See Note**	49-51

The stock timing crank gear may need to be chamfered to clear the larger radius on the snout of the crankshaft

Note: All 2012 and earlier 58 tooth reluctor wheels have a tooth width of .170"

All 2013 and later 58 tooth reluctor wheels have a tooth width of .130", along with a dimple in the rear face of the wheel. All reluctor wheels are attached with 4 fasteners.

Note: Manley crankshafts are not intended for use with highly boosted roots style cog belt superchargers

*Note: When installing these crankshafts in a VVT engine, you also need to order a crankshaft gear spacer part number **42000**.

** These cranks are not balanced and have non-drilled counterweights

Precision Balancing Information

Part No.	Bobweight Modification
04004-1	Precision balancing the crankshaft from -200 to -71 grams from the published bobweight
04000-1	Precision balancing the crankshaft from -70 to +20 grams from the published bobweight
04005-1	Precision balancing the crankshaft from +21 to +80 grams from the published bobweight
04006-1	Precision balancing the crankshaft from +81 to +160 grams from the published bobweight

With our "PRO SERIES" 4.050" stroke small block HEMI crankshafts, we have the ability to offer our customers complete rotating assemblies utilizing Manley Platinum Series pistons and Manley H-Beam or Pro Series I-Beam connecting rods. **See Pages 179-180.**

CUSTOM ROTATING ASSEMBLIES

Chrysler 5.7L/6.1L/6.4L Rotating Assemblies

Ordering a Manley SB HEMI rotating assembly is as easy as 1-2-3...

1. Choose your crankshaft part number based on required reluctor wheel for your vehicle and order the corresponding rod and main bearing part numbers shown
2. Choose your connecting rod part number
3. Choose your piston part number based on bore size and desired compression ratio and the corresponding piston ring part number

Ordering all of the required components for your SB HEMI rotating assembly from Manley will result in extra \$ savings. Please contact your Manley representative for more details.

Order part number **04000-1** for precision balancing to within 5 grams

CRANKS

- ▶ Lightweight 4340 material forging
- ▶ Multi-step heat treatment process and nitrided for added strength
- ▶ Stress relieved, shot-peened and 100% magnafluxed
- ▶ Micro polished large radius journals
- ▶ Available with either 32 or 58 tooth reluctor wheels
- ▶ Gun drilled mains and lightened rod journals for weight reduction
- ▶ Counterweights fully profiled

RODS

- ▶ Lightweight design 4340 material forgings
- ▶ Fully machined, heat treated, stress relieved, shot peened and 100% magnafluxed
- ▶ Big and small end bores are final honed to a tolerance of $\pm .0002$ "
- ▶ Bend and twist is tightly controlled
- ▶ Weight matched to +/- 1.5 grams
- ▶ H-Beam comes standard with 7/16" ARP 8740 bolts (affix an R suffix for ARP 2000 bolt upgrade)
- ▶ H-Tuff comes standard with 7/16" ARP 2000 bolts
- ▶ I-Beam comes standard with 7/16" ARP 2000 bolts (affix an R6 suffix for ARP 625+ bolt upgrade)

PISTONS

- ▶ High strength 2618 alloy forgings
- ▶ Exacting ring groove squareness to cylinder wall provides maximum horsepower.
- ▶ Offset wrist pin design
- ▶ Premium Chrome Moly pin included with Standard Series
- ▶ 9310 Alloy pin included with Extreme Duty Series
- ▶ Moly coated skirts

RINGS

- ▶ 1.5 x 1.5 x 3mm Total Seal (moly in-lay tops standard)
- ▶ Premium steel top rings are optional (affix ST suffix)
- ▶ Total Seal Gapless® steel top ring sets also available (affix GT suffix)

BEARINGS

- ▶ Premium Clevite® "H" Series narrowed rod bearings and "P" Series or "H" Series main bearings

Chrysler 5.7L Hemi Series

Lightweight 1730gm. Bobweight 4.050" Stroke Cranks

Crank P/N Reluctor Wheel	Piston Part No.	Extreme Duty Part No.	Piston Description	Ring Part No.	Compression Ratio			Balance Req. (Y/N)		
					85cc	65cc	74cc	14056-8	15056R-8	14255-8
191832 32 Tooth Up to 2008 or 191858 58 Tooth 2009-2012 or 191958 58 Tooth 2013 - Up	597200C-8	597200CE-8	3.917/-1.5cc F/T	46120-8	9.33:1	11.52:1	10.41:1	N*	Y	Y
	597205C-8	597205CE-8	3.922/-1.5cc F/T	46121-8	9.35:1	11.54:1	10.43:1	N*	Y	Y
	597220C-8	597220CE-8	3.937/-1.5cc F/T	46122-8	9.41:1	11.62:1	10.50:1	N*	Y	Y
6.125" Rod P/N Description	597300C-8	597300CE-8	3.917/-14cc Dish	46120-8	8.37:1	10.03:1	9.20:1	N*	Y	Y
	597305C-8	597305CE-8	3.922/-14cc Dish	46121-8	8.39:1	10.06:1	9.22:1	N*	Y	Y
	597320C-8	597320CE-8	3.937/-14cc Dish	46122-8	8.44:1	10.12:1	9.28:1	N*	Y	Y
14056-8 H-Beam or 15056R-8 H-Tuff or 14255-8 SW I-Beam	598500C-8	598500CE-8	3.917/-23cc Dish	46120-8	7.80:1	9.20:1	8.51:1	N*	Y	Y
	598505C-8	598505CE-8	3.922/-23cc Dish	46121-8	7.82:1	9.22:1	8.53:1	N*	Y	Y
	598520C-8	598520CE-8	3.937/-23cc Dish	46122-8	7.87:1	9.28:1	8.58:1	N*	Y	Y
Bearing P/N Description										
	30020 or 30020X* Rod 33050 or 33050H Main									

*N = Factory balanced to +/- 1% of bobweight

Order part number **04000-1** for precision balancing to within 5 grams

Note: "SW" = "Standard Weight" design rod

* HX Series rod bearings with .001" extra clearance

CUSTOM ROTATING ASSEMBLIES

Chrysler 6.1L Hemi Series

Lightweight 1730gm. Bobweight 4.050" Stroke Cranks

Crank P/N Reluctor Wheel	Piston Part No.	Extreme Duty Part No.	Piston Description	Ring Part No.	Compression Ratio 74cc	Balance Req. (Y/N)		
						14056-8	15056R-8	14255-8
191832 32 Tooth	597860C-8	597860CE-8	4.060/-1.5cc F/T	46116-8	10.72:1	Y	Y	Y
	597865C-8	597865CE-8	4.065/-1.5cc F/T	46116-8	10.74:1	Y	Y	Y
	597880C-8	597880CE-8	4.080/-1.5cc F/T	46118-8	10.81:1	Y	Y	Y
6.125" Rod P/N Description	598660C-8	598660CE-8	4.060/-11.5cc Dish	46116-8	9.73:1	Y	Y	Y
	598665C-8	598665CE-8	4.065/-11.5cc Dish	46116-8	9.75:1	Y	Y	Y
14056-8 H-Beam or 15056R-8 H-Tuff	598680C-8	598680CE-8	4.080/-11.5cc Dish	46118-8	9.82:1	Y	Y	Y
	14255-8 SW I-Beam	598760C-8	598760CE-8	4.060/-24cc Dish	46116-8	8.75:1	N*	Y
Bearing P/N Description	598765C-8	598765CE-8	4.065/-24cc Dish	46116-8	8.77:1	N*	Y	Y
	598780C-8	598780CE-8	4.080/-24cc Dish	46118-8	8.82:1	Y	Y	Y
30020 or 30020X* Rod								
33050 or 33050H Main								

Chrysler 6.4L Hemi Series

Lightweight 1730gm. Bobweight 4.050" Stroke Cranks

Crank P/N Reluctor Wheel	Piston Part No.	Extreme Duty Part No.	Piston Description	Ring Part No.	Compression Ratio 72cc	Balance Req. (Y/N)		
						14056-8	15056R-8	14255-8
191858 58 Tooth 2011-2012 or 191958 58 Tooth 2013 - Up	599800C-8	599800CE-8	4.090/-5cc Dish	46129ST-8	11.00	Y	Y	Y
	599805C-8	599805CE-8	4.095/-5cc Dish	46130ST-8	11.01	Y	Y	Y
	599810C-8	599810CE-8	4.100/-5cc Dish	46131ST-8	11.02	Y	Y	Y
6.125" Rod P/N Description	599900C-8	599900CE-8	4.090/-20.5cc Dish	46129ST-8	9.50	Y	Y	Y
	599905C-8	599905CE-8	4.095/-20.5cc Dish	46130ST-8	9.51	Y	Y	Y
	599910C-8	599910CE-8	4.100/-20.5cc Dish	46131ST-8	9.52	Y	Y	Y
14056-8 H-Beam or 15056R-8 H-Tuff								
Bearing P/N Description								
30020 or 30020X* Rod								
33050 or 33050H Main								



*N = Factory balanced to +/- 1% of bobweight
Order part number 04000-1 for precision balancing to within 5 grams

Note: "SW" = "Standard Weight" design rod
* HX Series rod bearings with .001" extra clearance

CRANKS & KITS

Ford 351C & Windsor (2.750" Main) Crankshafts

- ▶ 4340 material forgings
- ▶ Multi-step heat treatment process and nitrided for added strength
- ▶ Stress relieved, shot-peened and 100% magnafluxed
- ▶ Micro polished large radius journals (narrowed rod bearings required)
- ▶ Lightened rod journals for weight reduction
- ▶ Counterweights fully profiled

Part No.	Stroke	Minimum Rod Length	Main Journal Diameter	Rod Journal Diameter	Bobweight (grams)	Total Weight (lbs.)
190330*	3.850"	6.125"	2.750"	2.100"	1800	58-60
190340**	4.100"	6.200"	2.750"	2.100"	1860	58-60

* 3.850" stroke crank intended for use with Cleveland 9.200" deck blocks with 2.750" mains

** 4.100" stroke crank intended for use with Windsor 9.500" deck aftermarket blocks with 2.750" mains

Note: Manley crankshafts are not intended for use with highly boosted roots style cog belt superchargers

Precision Balancing Information

Part No.	Bobweight Modification
04004-1	Precision balancing the crankshaft from -200 to -71 grams from the published bobweight
04000-1	Precision balancing the crankshaft from -70 to +20 grams from the published bobweight
04005-1	Precision balancing the crankshaft from +21 to +80 grams from the published bobweight
04006-1	Precision balancing the crankshaft from +81 to +160 grams from the published bobweight

Ford 351C & Windsor (2.750" Main) w/ Cleveland Heads

Rotating Assemblies

- ▶ 4340 Forged steel crankshaft
- ▶ 4340 Forged steel H-Beam connecting rods with 7/16" ARP 8740 or optional ARP 2000 cap screws (P/N's 28438 & 28445) and Pro Series I-Beam Lightweight connecting rods with 7/16" ARP 2000 cap screws standard (P/N's 39393 & 39395)
- ▶ 2618 Forged aluminum Platinum Series pistons with Premium Chrome Moly wrist pins
- ▶ Total Seal® piston rings & high performance Clevite® "H" Series rod bearings (narrowed) and "P" or "H" Series main bearings

Note: All rotating assemblies listed below are factory balanced to within +/- 1% of bobweight. Order part number 04000-1 for precision balancing to within 5 grams

Part No.	Stroke	CID	Crank P/N	Rod Length	Rod P/N	Bore Size	Piston P/N	Piston Type	Compression Ratio				Piston Ring Package	Piston Ring P/N
									62cc	64cc	72cc	80cc		
39393*	3.850"	393	190330	6.125"	14355	4.030"	599330-8	Flat -3.5cc	11.7	11.4	10.4	9.6	1.5mm, 3mm	46113
39395*	3.850"	395	190330	6.125"	14355	4.040"	599340-8	Flat -3.5cc	11.7	11.5	10.5	9.7	1.5mm, 3mm	46114
28438**	4.100"	438	190340	6.250"	14067	4.125"	599400-8	Dish -11cc	11.9	11.7	10.7	10.0	1.5mm, 3mm	46360
28445**	4.100"	445	190340	6.250"	14067	4.155"	599430-8	Dish -11cc	12.1	11.8	10.9	10.1	1.5mm, 3mm	46363

* 3.850" stroke crank intended for use with Cleveland 9.200" deck blocks with 2.750" mains

** 4.100" stroke crank intended for use with Windsor 9.500" deck aftermarket blocks with 2.750" mains

Add an "R" to the assembly part number to order the optional ARP 2000 rod bolt upgrade

Add an "H" to the assembly part number to order the optional "H" Series main bearings

Add an "X" to the assembly part number to order the optional "X" Series rod bearings with .001" extra clearance

Bearing Chart

Clevite® "H" Series Rod Bearings	Clevite® "HX" Series Rod Bearings	Clevite® "P" Series Main Bearings	Clevite® "H" Series Main Bearings
30010	30010X	33100	33100H

CRANKSHAFTS & ROTATING ASSEMBLIES

Ford 4.6L Modular

Manley Performance "PRO SERIES" crankshafts designed for the Ford 4.6L Modular engine... Manufactured from a premium 4340 steel forging, these cranks feature either the stock 3.543" stroke or an increased stroke of 3.750", turning your 4.6L into a 5.0L or larger depending on your bore.

- ▶ 4340 material forgings
- ▶ Multi-step heat treatment process and nitrided for added strength
- ▶ Stress relieved, shot-peened and 100% magnafluxed
- ▶ Micro polished large radius journals (narrowed rod bearings required)
- ▶ Lightened rod journals for weight reduction
- ▶ Counterweights fully profiled



Part No.	Stroke	Minimum Rod Length	Main Journal Diameter	Rod Journal Diameter	Bobweight (grams)	Total Weight (lbs.)
190350	3.543"	5.933"	2.6572"	2.0863"	unbalanced	51-53
190360	3.750"	5.850"	2.6572"	2.0000"	unbalanced	51-53

The stock timing crank gear may need to be chamfered to clear the larger radius on the snout of the crankshaft. These crankshafts are designed with an 8 bolt pattern flywheel. They can be used in place of 6 bolt pattern crankshafts when used along with an OEM or aftermarket 8 bolt flywheel.

Note: Manley crankshafts are not intended for use with highly boosted roots style cog belt superchargers

Precision Balancing Information

Part No.	Bobweight Modification
04004-1	Precision balancing the crankshaft from -200 to -71 grams from the published bobweight
04000-1	Precision balancing the crankshaft from -70 to +20 grams from the published bobweight
04005-1	Precision balancing the crankshaft from +21 to +80 grams from the published bobweight
04006-1	Precision balancing the crankshaft from +81 to +160 grams from the published bobweight

Ford Mod "Ready To Run" Rotating Assemblies

- ▶ Lightweight 4340 forged steel crankshaft
- ▶ 4340 Forged steel H-Beam connecting rods with 3/8" ARP 8740 cap screws or optional ARP 2000 cap screws
- ▶ 2618 Forged aluminum Platinum Series pistons with Premium Chrome Moly wrist pins
- ▶ Total Seal® piston rings & high performance Clevite® "H" Series rod bearings (narrowed)
- ▶ Available as an Unbalanced (NOT Ready To Run) or a Precision Balanced (Ready To Run) assembly

Unbalanced Part No.	Precision Balanced Part No.	Stroke	CID	Crank P/N	Rod Length	Rod P/N	Bore Size	Piston P/N	Piston Type	Compression Ratio			Piston Ring Package	Piston Ring P/N
										42cc	51cc	52cc		
2 & 4 VALVE CYLINDER HEAD														
28120UB*	28120PB*	3.543"	284	190350	5.933"	14042	3.572"	594120C	Dish -11cc	10.64	9.39	9.27	1.5mm, 3mm	46620
29220UB*	29220PB*	3.750"	300	190360	5.850"	14044	3.572"	595220C	Dish -18cc	10.14	9.06	8.96	1.5mm, 3mm	46620
3 VALVE CYLINDER HEAD														
28320UB*	28320PB*	3.543"	284	190350	5.933"	14042	3.572"	594320C	Dish -6.5cc	-	9.95	-	1.5mm, 3mm	46620
29520UB*	29520PB*	3.750"	300	190360	5.850"	14044	3.572"	595520C	Dish -14cc	-	9.51	-	1.5mm, 3mm	46620

*Main bearings not included with kit. Order part number 33120 (Romeo Iron), 33130 (Windsor Iron) or 33140 (Windsor Aluminum).

Add an "R" to the assembly part number to order the optional ARP 2000 rod bolt upgrade

CRANKS & KITS

CUSTOM ROTATING ASSEMBLIES

Ford Modular 4.6L Rotating Assemblies

Ordering a Manley Ford Mod rotating assembly is as easy as 1-2-3.....

1. Choose your crankshaft part number based on stroke and order the corresponding rod and main bearing part numbers shown
2. Choose your connecting rod part number
3. Choose your piston part number based on bore size and desired compression ratio along with the corresponding piston ring part number

Ordering all of the required components for your Ford Mod rotating assembly from Manley will result in extra \$ savings. Please contact your Manley representative for more details.

CRANKS

- ▶ Lightweight 4340 material forgings
- ▶ Multi-step heat treatment process and nitrided for added strength
- ▶ Stress relieved, shot-peened and 100% magnafluxed
- ▶ Micro polished large radius journals
- ▶ Lightened rod journals for weight reduction
- ▶ Counterweights fully profiled

RODS

- ▶ Lightweight design 4340 material forgings
- ▶ Fully machined, heat treated, stress relieved, shot peened and 100% magnafluxed
- ▶ Big and small end bores are final honed to a tolerance of +/- .0002"
- ▶ Bend and twist is tightly controlled
- ▶ Weight matched to +/- 1.5 grams
- ▶ H-Beam comes standard with 3/8" ARP 8740 bolts (affix an R suffix for ARP 2000 bolt upgrade)
- ▶ H-Tuff comes standard with 3/8" ARP 2000 bolts
- ▶ I-Beam comes standard with 7/16" ARP 2000 bolts (affix an R6 suffix for ARP 625+ bolt upgrade)

PISTONS

- ▶ High strength 2618 alloy forgings
- ▶ Exacting ring groove squareness to cylinder wall provides maximum horsepower.
- ▶ Offset wrist pin design
- ▶ Premium Chrome Moly pin included with Standard Series
- ▶ 9310 Alloy pin included with Extreme Duty Series
- ▶ Moly coated skirts

RINGS

- ▶ 1.5 x 1.5 x 3mm Total Seal (moly in-lay tops standard)
- ▶ Premium steel top rings are optional (affix ST suffix)
- ▶ Total Seal Gapless® steel top ring sets also available (affix GT suffix)

BEARINGS

- ▶ Premium Clevite® "H" Series narrowed rod bearings and "P" Series or "H" Series main bearings

FORD 4.6L SOHC 3 VALVE (2004-up)

Lightweight unbalanced 3.543" Stroke Crank

Crank P/N	Standard Part No.	Extreme Duty Part No.	Piston Description	Ring Part No.	Comp. Ratio 51cc	Balance Req. (Y/N) H-Beam	Balance Req. (Y/N) H-Tuff	Balance Req. (Y/N) SW I-Beam
190350	594300C-8	594300CE-8	3.552/-6.5cc Dish	46600-8	9.86	Y	Y	Y
Rod P/N Description	594320C-8	594320CE-8	3.572/-6.5cc Dish	46620-8	9.95	Y	Y	Y
	594330C-8	594330CE-8	3.582/-6.5cc Dish	46630-8	10.00	Y	Y	Y
14042-8 H-Beam or 15042R-8 H-Tuff or 14518-8 SW I-Beam	594500C-8	594500CE-8	3.552/-14cc Dish	46600-8	8.94	Y	Y	Y
	594520C-8	594520CE-8	3.572/-14cc Dish	46620-8	9.03	Y	Y	Y
14518-8 SW I-Beam	594530C-8	594530CE-8	3.582/-14cc Dish	46630-8	9.07	Y	Y	Y
	594570C-8	594570CE-8	3.700/-14cc Dish	46670-8	9.58	Y	Y	Y
Bearing P/N Description Block Type		30120 or 30120X* Rod All	33120 or 33120H Main Romeo Iron	33130 or 33130H Main Windsor Iron	33140 or 33140H Main Windsor Aluminum			

Lightweight unbalanced 3.750" Stroke Crank

Crank P/N	Standard Part No.	Extreme Duty Part No.	Piston Description	Ring Part No.	Comp. Ratio 51cc	Balance Req. (Y/N) H-Beam	Balance Req. (Y/N) LW I-Beam	Balance Req. (Y/N) SW I-Beam
190360	595500C-8	595500CE-8	3.552/-14cc Dish	46600-8	9.41	Y	Y	Y
Rod P/N Description	595520C-8	595520CE-8	3.572/-14cc Dish	46620-8	9.51	Y	Y	Y
	595530C-8	595530CE-8	3.582/-14cc Dish	46630-8	9.55	Y	Y	Y
14044-8 H-Beam or 14320-8 LW I-Beam or 14520-8 SW I-Beam	595570C-8	595570CE-8	3.700/-18cc Dish	46670-8	9.64	Y	Y	Y
Bearing P/N Description Block Type		30020 or 30020X* Rod All	33120 or 33120H Main Romeo Iron	33130 or 33130H Main Windsor Iron	33140 or 33140H Main Windsor Aluminum			

Note: "LW" = "Lightweight" design rod and "SW" = "Standard Weight" design rod
* HX Series rod bearings with .001" extra clearance

CUSTOM ROTATING ASSEMBLIES

FORD 4.6L SOHC/DOHC 2 & 4 VALVE (1991-up)

Lightweight unbalanced 3.543" Stroke Crank

Crank P/N	Standard Part No.	Extreme Duty Part No.	Piston Description	Ring Part No.	Comp. Ratio			Balance Req. (Y/N)		
					42cc	51cc	52cc	H-Beam	H-Tuff	SW I-Beam
190350	594000C-8	594000CE-8	3.552/Flat Top	46600-8	12.65	10.86	10.69	Y	Y	Y
Rod P/N Description	594020C-8	594020CE-8	3.572/Flat Top	46620-8	12.78	10.97	10.80	Y	Y	Y
	594030C-8	594030CE-8	3.582/Flat Top	46630-8	12.85	11.02	10.85	Y	Y	Y
14042-8 H-Beam or 15042R-8 H-Tuff or 14518-8 SW I-Beam	594070C-8	594070CE-8	3.700/Flat Top	46670-8	13.55	11.63	11.45	Y	Y	Y
	594100C-8	594100CE-8	3.552/-11cc Dish	46600-8	10.53	9.29	9.18	Y	Y	Y
	594120C-8	594120CE-8	3.572/-11cc Dish	46620-8	10.64	9.39	9.27	Y	Y	Y
	594130C-8	594130CE-8	3.582/-11cc Dish	46630-8	10.69	9.43	9.31	Y	Y	Y
594170C-8	594170CE-8	3.700/-11cc Dish	46670-8	11.33	9.99	9.86	Y	Y	Y	
594200C-8	594200CE-8	3.552/-18cc Dish	46600-8	9.54	8.53	8.44	Y	Y	Y	
594220C-8	594220CE-8	3.572/-18cc Dish	46620-8	9.63	8.63	8.52	Y	Y	Y	
594230C-8	594230CE-8	3.582/-18cc Dish	46630-8	9.68	8.66	8.56	Y	Y	Y	
594270C-8	594270CE-8	3.700/-18cc Dish	46670-8	10.21	9.13	9.03	Y	Y	Y	
594400C-8	594400CE-8	3.552/-23cc Dish	46600-8	8.95	8.07	7.98	Y	Y	Y	
594420C-8	594420CE-8	3.572/-23cc Dish	46620-8	9.04	8.15	8.06	Y	Y	Y	
594430C-8	594430CE-8	3.582/-23cc Dish	46630-8	9.08	8.19	8.10	Y	Y	Y	
594470C-8	594470CE-8	3.700/-23cc Dish	46670-8	9.58	8.64	8.54	Y	Y	Y	
Bearing P/N Description Block Type	30120 or 30120X* Rod All		33120 or 33120H Main Romeo Iron	33130 or 33130H Main Windsor Iron	33140 or 33140H Main Windsor Aluminum					



CRANKS & KITS

Note: "SW" = "Standard Weight" design rod

* HX Series rod bearings with .001" extra clearance

CUSTOM ROTATING ASSEMBLIES

FORD 4.6L SOHC/DOHC 2 & 4 VALVE (1991-up)

Lightweight unbalanced 3.750" Stroke Crank

Crank P/N	Standard Part No.	Extreme Duty Part No.	Piston Description	Ring Part No.	Comp. Ratio			Balance Req. (Y/N)		
					42cc	51cc	52cc	H-Beam	LW I-Beam	SW I-Beam
190360	595000C-8	595000CE-8	3.552/Flat Top	46600-8	13.33	11.43	11.26	Y	Y	Y
Rod P/N Description	595020C-8	595020CE-8	3.572/Flat Top	46620-8	13.47	11.55	11.37	Y	Y	Y
	595030C-8	595030CE-8	3.582/Flat Top	46630-8	13.54	11.61	11.43	Y	Y	Y
14044-8 H-Beam or	595100C-8	595100CE-8	3.552/-11cc Dish	46600-8	11.09	9.78	9.65	Y	Y	Y
	14320-8	595120C-8	595120CE-8	3.572/-11cc Dish	46620-8	11.20	9.88	9.75	Y	Y
LW I-Beam or	595130C-8	595130CE-8	3.582/-11cc Dish	46630-8	11.25	9.92	9.80	Y	Y	Y
	14520-8	595200C-8	595200CE-8	3.552/-18cc Dish	46600-8	10.04	8.97	8.87	Y	Y
SW I-Beam	595220C-8	595220CE-8	3.572/-18cc Dish	46620-8	10.14	9.06	8.96	Y	Y	Y
	595230C-8	595230CE-8	3.582/-18cc Dish	46630-8	10.19	9.11	9.00	Y	Y	Y
	595270C-8	595270CE-8	3.700/-18cc Dish	46670-8	10.75	9.61	9.50	Y	Y	Y
	595400C-8	595400CE-8	3.552/-23cc Dish	46600-8	9.41	8.48	8.39	Y	Y	Y
	595420C-8	595420CE-8	3.572/-23cc Dish	46620-8	9.51	8.57	8.47	Y	Y	Y
	595430C-8	595430CE-8	3.582/-23cc Dish	46630-8	9.55	8.61	8.52	Y	Y	Y
	595470C-8	595470CE-8	3.700/-23cc Dish	46670-8	10.08	9.08	8.98	Y	Y	Y
	595600C-8	595600CE-8	3.552/-28cc Dish	46600-8	8.87	8.05	7.97	Y	Y	Y
	595620C-8	595620CE-8	3.572/-28cc Dish	46620-8	8.96	8.13	8.05	Y	Y	Y
	595630C-8	595630CE-8	3.582/-28cc Dish	46630-8	9.00	8.17	8.09	Y	Y	Y
	595670C-8	595670CE-8	3.700/-28cc Dish	46670-8	9.50	8.62	8.53	Y	Y	Y
Bearing P/N Description Block Type	30020 or 30020X* Rod All		33120 or 33120H Main Romeo Iron	33130 or 33130H Main Windsor Iron	33140 or 33140H Main Windsor Aluminum					



MPR Racing Engines

Note: "LW" = "Lightweight" design rod and "SW" = "Standard Weight" design rod
* HX Series rod bearings with .001" extra clearance