



MADE IN USA  
• SINCE 1983 •

# **OLIVER**

## RACING PARTS



## **2020 PRODUCT CATALOG**

CRAFTSMANSHIP • PRECISION • DURABILITY • STRENGTH

SALES@OLIVERRACINGPARTS.COM • WWW.OLIVERRACINGPARTS.COM • (231) 237 - 4515

# OLIVER

RACING PARTS

## OLIVER Rods Are Better By Design™

All Oliver rods are precision-machined using only premium mill-certified aircraft quality E4340 AQ chrome moly alloy, heat-treated to produce a 100% martensite grain structure.



- **2X DOUBLE Heat Treat**

Full Stress Relief After Rough Machining  
Quench and Tempered for 100% martensitic grain structure for optimized durability and strength

- **4340 AQ Material**

Higher grade more expensive than standard meeting AMS2301 vacuum furnace degassed for higher cleanliness and improved strength

- **Narrow Bore Spacing**

Tightest bore spacing in the industry increasing clamp load at the big end bore split joint and maintaining bore/bushing roundness

- **In Process Air Gauging**

Most accurate bore measurement possible  
Parallelism and concentricity implemented prior to the hone operation opens up the potential for extremely consistent bores for the gauging of the part. With only .002 travel and a measurement tolerance of .00002, our gauges offer the ability to control the part and therefore, give us authority over the entire gauging process.

- **Parabolic Beam Design**

Oliver I-beam connecting rods feature our exclusive "Parabolic Beam®" design that reduces beam stress and delivers the highest strength-to-weight ratio of any

## About Us: Oliver Racing Parts

Achieving the tightest tolerances possible has and always will be our highest priority. Our dialed-in, straightforward manufacturing protocols foster unquestionable repeatability. For example, throughout the entire multi-step process, Oliver's connecting rods are constantly tested against the same three reference points, known as datums A, B, and C. These three points serve as the foundation upon which every single part at Oliver is manufactured. The utilization of premium materials, cutting-edge measurement techniques, top-of-the-line quality control, and extreme attention to detail is proof of our unwavering commitment to a finished product we stand behind, every single time. At Oliver we are striving to erase even the smallest traces of variation in our racing parts altogether.



### Every manufacturing operation we perform revolves around a specific control processing technique called Geometric Dimensioning and Tolerancing (GD&T)

GD&T serves as the cornerstone of Oliver's commitment to provide championship-winning racers with the highest quality connecting rods. Control drawings that govern key dimensioning and tolerancing, fixtures that locate off key Datum points, and our state-of-the-art climate controlled facility ensure Oliver's machining and measurements are absolutely repeatable. Oliver implements the same elite processes used by the world's top tier precision machining companies. Our Zeiss CMM and Sunnen SH4000 electro servo honing machine demonstrate our commitment to invest in the latest, most ad-vanced technologies, undoubtedly placing us at forefront of the racing industry.

Oliver is devoted to extracting every last benefit from our U.S. alloy steel for our racers. From the very start of production, our material is processed using a higher standard for cleanliness and purity, meeting AMS 2301. Our proprietary two-stage heat treatment optimizes stress relief and provides su-perior grain structure and ideal grain size. We continuously strive to give our racers the "unfair" ad-vantage. Oliver rods are better by design.

# MADE IN USA • SINCE 1983 •

## Our Products

### Oliver Rods are Better By Design™

Oliver I-beam connecting rods feature our exclusive “Parabolic Beam®” design that reduces beam stress and delivers the highest strength-to-weight ratio of any connecting rod currently made.

Our Standard Light rods have been designed for the heart of the racing engine category. These rods represent the perfect balance between weight and strength. In applications where weight is the primary concern we offer our Ultra Light series. For those of you pushing beyond the limits where weight takes a back seat to absolute strength, our Speedway and Max series rods are the only answer.

All Oliver rods are precision-machined using only premium mill-certified aircraft quality E4340 AQ chrome moly alloy, heat-treated to produce 100% martensite grain structure.

“Parabolic Beam®” is a registered trademark of Oliver Racing Parts, Inc.

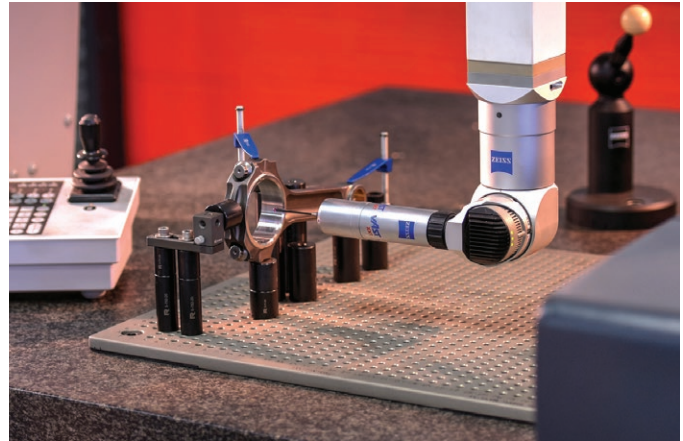

## The Meaning Of “MADE IN AMERICA”

Oliver connecting rods are made in America, from 100% American materials by the finest craftsmen in the world: Americans. Throughout our catalog we proudly display the American flag and use the term “Made in America” in honor of that commitment.

For generations, “Made in America” has signified the quality, durability and innovation of the product that bore the mark. We believe that is still true today.

Our success is the result of years of continuous product development. Our rod designs have been refined with feedback from the world’s best engine builders racing everywhere from the biggest NASCAR venues to local dirt tracks all over the U.S. and around the world. Our experience cannot be copied. Our knowledge of what works and what does not is without equal.

We do not and will not cut corners. We utilize the best materials from the finest suppliers. We use best practices in design and manufacturing. Each and every Oliver rod is built with Craftsmanship, Precision, Durability and Strength.

The fact is, we build what are arguably the best connecting rods in the world using American craftsmen and American materials. Oliver connecting rods are proudly, “Made in America.”

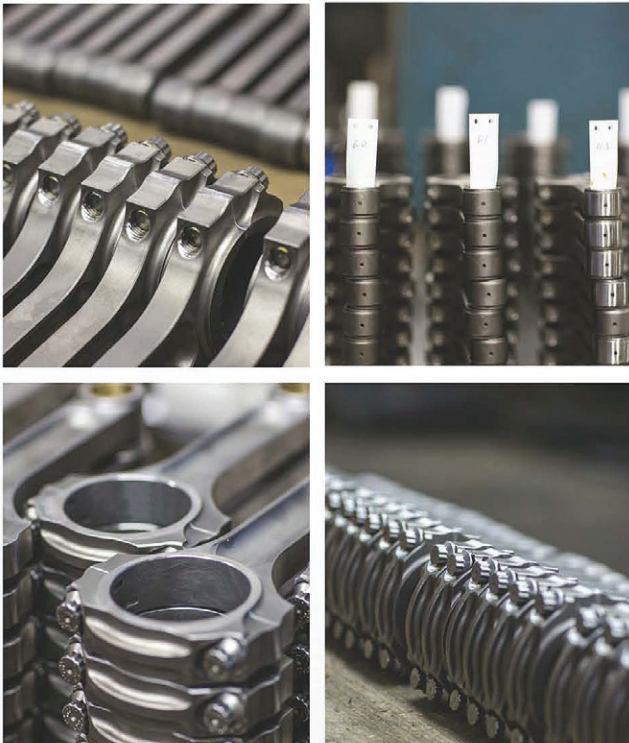

# Precision Support Equipment



## **ZEISS CMM - Coordinate Measuring Machine (CMM)**

The ZEISS CMM provides ultimate dimensional information directly on the production line. The temperature control on our shop floor makes it possible for the ZEISS CMM to perform within the actual production line through the facility's tightly controlled atmospheric pressure and climate. This elite machine offers maximum efficiency when it comes to in-production waiting times, but quality control remains our top priority. Most importantly, the ZEISS CMM establishes reliable reproducibility through top-of-the-line software and technology, erasing any uncertainty or fluctuations as a result of outdated manual measuring techniques.

## **Sunnen Hone**

Designed to achieve exceptional finish quality, the Sunnen Hone SH-4000 is the next generation of power-stroke honing machines. With 45 percent fewer parts and greater reliability than its mechanical predecessors, the SH-4000 introduces patent-pending digital-servo tool feed and cutting pressure control for consistent, predictable performance with micron tolerances. By controlling parallelism and concentricity leading up to the final honing operation, less demand is placed on the honing operation, giving Oliver the ability to maintain optimum surface finish characteristics. Less stock removal, combined with improved parallelism and concentricity reduces the need for adjustments, ultimately leading to better tooling life throughout the honing process.

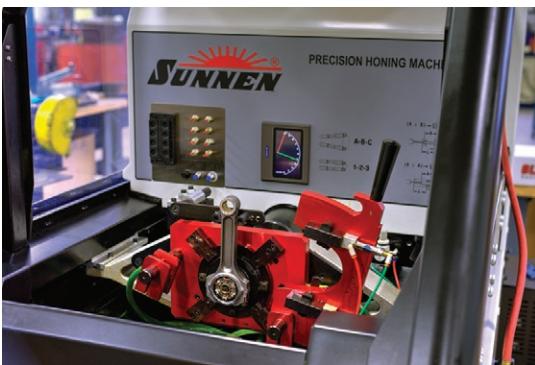

## **Air Gauge**

Working with the tightest of tolerances, air gauging as a measurement method is critical to Oliver's accurate high volume manufacturing process. Parallelism and concentricity implemented prior to the hone operation opens up the potential for extremely consistent bores for the gauging of the part. With only .002 travel and a measurement tolerance of .00002, our gauges offer the ability to control the part and therefore, give us authority over the entire gauging process. Lastly, we run the air through a dryer and two micron filters to generate consistent dry air for every single measurement. When measuring rod diameters down to the most extremely precise points, air gauges are not only one of the most elite choices, but they also take out any chance of a flawed or limited mechanical instrument entirely.



# SMALL BLOCK CHEVY

STANDARD / ULTRA LIGHT / SPEEDWAY

## Standard Light Series:

Oliver's Standard Light Series rods are designed to be used in naturally-aspirated high horsepower, high-RPM engines. This workhorse rod is used in applications such as late-model stock cars, 410 cubic inch sprint cars and late model dirt cars.

*This rod features premium 7/16" bolts.*



*Standard Light Series, Standard Journal*

## STANDARD JOURNAL

0.927 Wrist Pin / 2.100 Crank Pin /  
0.940 Big End Width / 2.225 Big End Bore

Part Number	Rod Length	Weight* Recip/Rotate/Total (gr)
C5700STLT8	5.700"	180/ 470 /650
C5850STLT8	5.850"	184/ 473 /657
C6000STLT8	6.000"	190/ 475 /665
C6125STLT8	6.125"	190/ 480 /670
C6200STLT8	6.200"	192/ 480 /672
C6250STLT8	6.250"	195/ 482 /677
C6300STLT8	6.300"	193/ 487 /680

## SMALL JOURNAL

0.927 Wrist Pin / 2.000 Crank Pin /  
0.940 Big End Width / 2.125 Big End Bore

Part Number	Rod Length	Weight* Recip/Rotate/Total (gr)
C5700SMLT8	5.700"	179/ 459 /638
C5850SMLT8	5.850"	185/ 465 /650
C6000SMLT8	6.000"	188/ 467 /655
C6125SMLT8	6.125"	190/ 475 /665
C6200SMLT8	6.200"	192/ 473 /665
C6250SMLT8	6.250"	194/ 473 /667
C6300SMLT8	6.300"	191/ 482 /673

*\*Approximate Weights  
Actual rod weight may vary*

## Professional Racers Win With Oliver Rods

- Precision machined by American craftsmen using American Mill-certified aircraft quality steel
- Engineered for durability, strength and performance for today's high-RPM engines
- Oliver Rods are designed and produced utilizing the latest in Finite Element Analysis (FEA), Statistical Process Control (SPC), Batch testing and the latest in modern inspection metrics that meet or exceed ISO quality standards

## Ultra Light Series:

Our Ultra Light Series rods are designed to be used in moderate horsepower applications where RPM in the 8,200 range are common. These rods are often used in 360 Sprint cars with spec heads or pavement late models. Lightweight pistons are recommended.

*This rod features premium 7/16" bolts.  
(1.889" journal rods have 3/8" ARP 2000 bolts)*

## STANDARD JOURNAL

0.927 Wrist Pin / 2.100 Crank Pin /  
0.940 Big End Width / 2.225 Big End Bore

Part Number	Rod Length	Weight*
		Recip/Rotate/Total (gr)
C5700STUL8	5.700"	155/ 440 /595
C5850STUL8	5.850"	160/ 440 /600
C6000STUL8	6.000"	165/ 445 /610
C6125STUL8	6.125"	165/ 455 /620
C6200STUL8	6.200"	166/ 455 /621
C6250STUL8	6.250"	166/ 440 /660

## SMALL JOURNAL

0.927 Wrist Pin / 2.000 Crank Pin /  
0.940 Big End Width / 2.125 Big End Bore

Part Number	Rod Length	Weight*
		Recip/Rotate/Total (gr)
C5700SMUL8	5.700"	155/ 430 /585
C5850SMUL8	5.850"	160/ 430 /590
C6000SMUL8	6.000"	160/ 430 /590
C6125SMUL8	6.125"	160/ 455 /605
C6200SMUL8	6.200"	166/ 455 /610

## QUAD 4 JOURNAL

0.927 Wrist Pin / 1.889 Crank Pin /  
0.940 Big End Width / 2.015 Big End Bore

Part Number	Rod Length	Weight*
		Recip/Rotate/Total (gr)
C5700Q4UL8	5.700"	155/ 412 /567
C5850Q4UL8	5.850"	160/ 415 /575
C6000Q4UL8	6.000"	160/ 420 /580
C6125Q4UL8	6.125"	160/ 426 /590



Speedway Series, Standard Journal

## Speedway Series:

Oliver Racing Parts' Speedway Series rods are designed for severe applications where engines are subject to high-RPM endurance racing or high loads over a wide variation in RPM. These rods are often used in large cubic inch late model dirt cars and forced-induction applications.

*This rod features premium 7/16" bolts.*

## STANDARD JOURNAL

0.927 Wrist Pin / 2.100 Crank Pin /  
0.940 Big End Width / 2.225 Big End Bore

Part Number	Rod Length	Weight*
		Recip/Rotate/Total (gr)
C5850STSW8	5.850"	207/ 493 /700
C6000STSW8	6.000"	210/ 495 /705
C6125STSW8	6.125"	215/ 500 /715
C6200STSW8	6.200"	215/ 500 /715
C6250STSW8	6.250"	216/ 505 /721
C6300STSW8	6.300"	217/ 508 /725

*\*Approximate Weights  
Actual rod weight may vary*

# LS CHEVY

## STANDARD / SPEEDWAY

For the “on-center” big end setups of the LS series engines, Oliver offers our tried and tested rod designs locating the beam to properly line up with the bore centers.

Our standard light (LT) beam comes in small journal (2” crankpin) and standard journal (2.100” crankpin) with the 6.125” center to center length.

We also make this length rod in standard journal (2.100” crankpin) in the Speedway Series (SW) for blown and turbocharged applications to 2000+ Hp.

In addition, we make the standard light se-ries (LT) in a 6.350” center to center length, standard journal (2.100” crankpin) for the 9.700 deck LSX series block.

*This rod features premium 7/16” bolts.*



*Standard Light Series, Standard Journal*

### Standard Light Series:

#### STANDARD JOURNAL

0.927 Wrist Pin / 2.100 Crank Pin /  
0.940 Big End Width / 2.225 Big End Bore

Part Number	Rod Length	Weight* Recip/Rotate/Total (gr)
L6125STLT8	6.125”	190/ 480 /670
L6250STLT8	6.250”	192/ 480 /672
L6350STLT8	6.350”	196/ 481 /677

#### SMALL JOURNAL

0.927 Wrist Pin / 2.000 Crank Pin /  
0.940 Big End Width / 2.125 Big End Bore

Part Number	Rod Length	Weight* Recip/Rotate/Total (gr)
L6125SMLT8	6.125”	190/ 475 /665

### Speedway Series:

#### STANDARD JOURNAL

0.927 Wrist Pin / 2.100 Crank Pin /  
0.940 Big End Width / 2.225 Big End Bore

Part Number	Rod Length	Weight* Recip/Rotate/Total (gr)
L6100STSW8	6.100”	212/ 506 /718
L6125STSW8	6.125”	214/ 499 /713
L6250STSW8	6.250”	215/ 510 /725

*\*Approximate Weights  
Actual rod weight may vary*



# BIG BLOCK CHEVY

Oliver's Big Block Series rods are designed to with-stand the high torque and heavy-hitting horsepower generated from today's naturally aspirated big block engines. This rod is used in Super-Modified asphalt cars and big cubic inch naturally-aspirated drag cars.

*This rod features premium 7/16" bolts.*



## Big Block Series:

### STANDARD JOURNAL

0.990 Wrist Pin / 2.200 Crank Pin /  
0.990 Big End Width / 2.325 Big End Bore

Part Number	Rod Length	Weight*
		Recip/Rotate/Total (gr)
C6135BB8	6.135" (stock)	240/ 555 /795
C6385BB8	6.385" (+.250)	245/ 568 /813
C6535BB8	6.535" (+.400)	250/ 570 /820
C6635BB8	6.635" (+.500)	250/ 575 /825
C6660BB8	6.660" (+.525)	252/ 570 /822
C6700BB8	6.700" (+.565)	255/ 570 /825
C6735BB8	6.735" (+.600)	255/ 575 /830
C6800BB8	6.800" (+.665)	255/ 575 /830

### SMALL JOURNAL

0.990 Wrist Pin / 2.100 Crank Pin /  
0.990 Big End Width / 2.225 Big End Bore

Part Number	Rod Length	Weight*
		Recip/Rotate/Total (gr)
C6385SMBB8	6.385" (+.250)	240/ 555 /795
C6535SMBB8	6.535" (+.400)	245/ 560 /805
C6700SMBB8	6.700" (+.565)	248/ 558 /806
C6800SMBB8	6.800" (+.665)	250/ 570 /830

*\*Approximate Weights  
Actual rod weight may vary*

# BIG BLOCK CHEVY MAX

The Oliver Big Block-Max Series rod is engineered for use in the most extreme applications where power adders are common, such as big block turbocharged or supercharged endurance motors and blown alcohol drag cars.

*This rod features premium 7/16" bolts.*



## Max Series:

### STANDARD JOURNAL

0.990 Wrist Pin / 2.200 Crank Pin /  
0.990 Big End Width / 2.325 Big End Bore

Part Number	Rod Length	Weight* Recip/Rotate/Total (gr)
C6385BBMX8	6.385" (+.250)	260/ 575 /835
C6535BBMX8	6.535" (+.400)	265/ 578 /843
C6635BBMX8	6.635" (+.500)	268/ 580 /848
C6700BBMX8	6.700" (+.565)	270/ 582 /852
C6800BBMX8	6.800" (+.665)	270/ 590 /860

### "TALL DECK"

0.990 Wrist Pin / 2.200 Crank Pin /  
0.990 Big End Width / 2.325 Big End Bore

Part Number	Rod Length	Weight* Recip/Rotate/Total (gr)
C7000BBMX8	7.000" (+.865)	280/ 590 /870
C7100BBMX8	7.100" (+.965)	281/ 595 /876

MADE IN USA   
• **SINCE 1983** •

# BIG BLOCK CHEVY MAX-PLUS



- Big Power Requires a Stronger Rod and Oliver Racing Delivers with Our New BBMX-PLUS
- 55% Increase in Area from Housing Bore to Bolt Spot Face Corner for Added Strength and Protection for High Horsepower Applications
- 12% Increase in Cap Rib Thickness to Protect from Deformation Of Cap During Stroke To BDC
- 4x Larger Radius @ Bolt Spot Face for Additional Strength and Big End Integrity

## Max-Plus Series:

### STANDARD JOURNAL

0.990 Wrist Pin / 2.200 Crank Pin /

0.990 Big End Width / 2.325 Big End Bore

Part Number	Rod Length	Weight*		
		Recip	Rotate	Total (gr)
C6385BBMXP8	6.385" (+.250)	259	616	875
C6535BBMXP8	6.535" (+.400)	267	617	884
C6635BBMXP8	6.635" (+.500)	268	623	891
C6700BBMXP8	6.700" (+.565)	269	626	895
C6800BBMXP8	6.800" (+.665)	272	626	898

### "TALL DECK"

0.990 Wrist Pin / 2.200 Crank Pin /

0.990 Big End Width / 2.325 Big End Bore

Part Number	Rod Length	Weight*		
		Recip	Rotate	Total (gr)
C7000BBMXP8	7.000" (+.865)	279	636	915
C7100BBMXP8	7.100" (+.965)	283	640	923

MADE IN USA   
• **SINCE 1983** •

# DURAMAX DIESEL

## Max Series:

### CHEVY DURAMAX DIESEL 6.6L

1.359 Wrist Pin / Stock Crank Pin / 1.120

Big End Width / 2.638 Big End Bore

Part Number	Rod Length	Weight* Recip/Rotate/Total (gr)
D6418MAX8	6.418"	403/ 762 /1165



# CHRYSLER BIG BLOCK

## Max Series:

### CHRYSLER BIG BLOCK

.990 Wrist Pin / 2.200 Crank Pin /

1.017 Big End Width / 2.325 Big End Bore

Part Number	Rod Length	Weight* Recip/Rotate/Total (gr)
MC7100BBMX8	7.100"	284/ 598 /882

## Max Series:

### CHRYSLER BIG BLOCK

.990 Wrist Pin / 2.200 Crank Pin /

1.017 Big End Width / 2.325 Big End Bore

Part Number	Rod Length	Weight* Recip/Rotate/Total (gr)
MC7100BBMXP8 <i>Made to order</i>	7.100"	N/A

# FORD SMALL BLOCK

## STANDARD / ULTRA LIGHT

We are moving forward with a renewed commitment to serving the needs of our Ford engine builder community by increasing inventory of these Ford specific rods and continuing to add new rods based on your feedback for the most popular applications.

We have taken the best attributes of our Standard Light, Ultra Light, and Speedway series rods and have utilized them in the most appropriate applications from 302/351 Windsor to the 4.6L and 5.4L Modular power-plants and "385" series applications.

While many of you have been using our 5.400 length (302 based) Ultra Light rod for years, we've added our Standard Light rod to our catalog for those of you looking for a rod capable of higher HP levels. For the 4.6L, we've added our Standard Light design rod, in addition to the Ultra Light, for those of you looking for a heavier duty rod to push the performance level of these powerplants even further. We've also transitioned our 5.850 length "Stroker" rod to the Standard Light beam to offer improved strength and durability for those of you pushing the 4.6L Modular into 302 territory and beyond. For the 5.4L Modular, we have added the Speedway version for extreme applications.

As with all Oliver rod's, our Ford Series rods are designed to withstand the abuse from today's high rpm naturally-as-pirated engines as well as high horsepower forced induction applications.

As cylinder head technology has advanced along with boost levels approaching 40psi on a normal basis, the need to update our Ford series rods with our best designs was a necessity to achieve the highest performance envelope possible.

*This rod features premium 7/16" bolts.*



Standard Light Series

## Standard Light Series:

### 302 WINDSOR

0.927 Wrist Pin / 2.123 Crank Pin /  
0.831 Big End Width / 2.239 Big End Bore

Part Number	Rod Length	Weight* Recip/Rotate/Total (gr)
F5400FDLT8	5.400"	177/ 434 /611

### SVO OFFSET/STANDARD JOURNAL

0.927 Wrist Pin / 2.100 Crank Pin /  
0.831 Big End Width / 2.225 Big End Bore

Part Number	Rod Length	Weight* Recip/Rotate/Total (gr)
F5400SVO-STLT8	5.400"	175/ 455 /630

### SVO OFFSET/SMALL JOURNAL

0.927 Wrist Pin / 2.000 Crank Pin /  
0.940 Big End Width / 2.125 Big End Bore

Part Number	Rod Length	Weight* Recip/Rotate/Total (gr)
F5400SVO-SMLT8	5.400"	187/ 450 /637

### 351 WINDSOR

0.927 Wrist Pin / 2.100 Crank Pin /  
0.940 Big End Width / 2.225 Big End Bore

Part Number	Rod Length	Weight* Recip/Rotate/Total (gr)
F6200SVO-STLT8	6.200"	196/ 485 /681

## Ultra Light Series:

### 302 WINDSOR

0.927 Wrist Pin / 2.123 Crank Pin /  
0.831 Big End Width / 2.239 Big End Bore

Part Number	Rod Length	Weight* Recip/Rotate/Total (gr)
F5400FDUL8	5.400"	153/ 412 /565

*\*Approximate Weights  
Actual rod weight may vary*

# FORD MODULAR

## STANDARD / ULTRA LIGHT / SPEEDWAY

### Standard Light Series:

#### MODULAR - 4.6L

0.866 or 0.927 Wrist Pin  
2.086 Crank Pin / 0.938 Big End Width /  
2.239 Big End Bore

Part Number	Rod Length	Weight* Recip/Rotate/Total (gr)
F5933MDLT8	5.933"	193/ 470 /663

#### MODULAR - 4.6L/"STROKER"

0.866 or 0.927 Wrist Pin / 2.000 Crank Pin /  
0.938 Big End Width / 2.125 Big End Bore

Part Number	Rod Length	Weight* Recip/Rotate/Total (gr)
F5850MD-SMLT8	5.850"	182/ 465 /647

### Ultra Light Series:

#### MODULAR - 4.6L

0.927 Wrist Pin (ONLY)  
2.086 Crank Pin / 0.938 Big End Width /  
2.239 Big End Bore

Part Number	Rod Length	Weight* Recip/Rotate/Total (gr)
F5933MDUL8	5.933"	159/ 410 /569

#### MODULAR - 5.4L

0.866 Wrist Pin (ONLY)  
2.086 Crank Pin / 0.938 Big End Width /  
2.239 Big End Bore

Part Number	Rod Length	Weight* Recip/Rotate/Total (gr)
F6657MDUL8	6.657"	172/ 438 /610

### Speedway Series:

#### MODULAR - 5.4L

0.866 or 0.927 Wrist Pin  
2.086 Crank Pin / 0.938 Big End Width /  
2.239 Big End Bore

Part Number	Rod Length	Weight* Recip/Rotate/Total (gr)
F6657MDSW8	6.657"	228/ 505 /733

# FORD 385 BIG BLOCK

## 385/ 385 MAX / 385 MAX-PLUS Series:

### "385" BIG BLOCK

0.990 Wrist Pin / 2.200 Crank Pin /  
0.990 Big End Width / 2.325 Big End Bore

Part Number	Rod Length	Weight* Recip/Rotate/Total (gr)
F6700BB8	6.700"	248/ 570 /818
F6800BB8	6.800"	255/ 580 /835

### "385 MAX" BIG BLOCK

0.990 Wrist Pin / 2.200 Crank Pin /  
0.990 Big End Width / 2.325 Big End Bore

Part Number	Rod Length	Weight* Recip/Rotate/Total (gr)
F6700BBMX8	6.700"	265/ 479 /844
F6800BBMX8	6.800"	273/ 582 /855

### "385 MAX-PLUS" BIG BLOCK

0.990 Wrist Pin / 2.200 Crank Pin /  
0.990 Big End Width / 2.325 Big End Bore

Part Number	Rod Length	Weight* Recip/Rotate/Total (gr)
F6700BBMXP8	6.700"	N/A
F6800BBMXP8	6.800"	273/ 582 /855

*\*Approximate Weights  
Actual rod weight may vary*

# SPORT COMPACT

## STANDARD / ULTRA LIGHT

Oliver's Sport Compact Series rods are designed for use in the sport compact applications where the small displacement, high-RPM engines are being modified to make large amounts of horse-power.

*This rod features premium 3/8" bolts.*

### Standard Light Series:

## MITSUBISHI/GENERATION 2 "TURBO EXTREME"

0.866 Wrist Pin / 1.038 Big End Width /  
1.890 Big End Bore

Part Number	Rod Length	Weight*
		Recip/Rotate/Total (gr)
MT5906LT4-G2	150mm	185/ 457 /642
MT6024LT4-G2	153mm	195/ 452 /648
MT6142LT4-G2	156mm	194/ 463 /657

### Ultra Light Series:

## MITSUBISHI/GENERATION 2

0.866 Wrist Pin / 1.038 Big End Width /  
1.890 Big End Bore

Part Number	Rod Length	Weight*
		Recip/Rotate/Total (gr)
MT5659EVO4	144mm	174/ 414 /588
MT5906UL4-G2	150mm	155/ 425 /580



*\*Approximate Weights  
Actual rod weight may vary*

MADE IN USA   
• **SINCE 1983** •

# OLIVER

## RACING PARTS

### ARP

ARP has been the key supplier to Oliver with the highest quality connecting rod bolts for the last 20 years. ARP is a family owned and run, American company manufacturing its products to the highest quality standards in the industry. All our bolts are custom designed to Oliver's specifications and meet the exacting AS9100/ISO9001 standards of ARP. The WSB bolt is rated to 220 ksi min tensile strength, the WSBX an updated and new material standard is rated to 240 ksi min tensile strength, while the ARP 3.5 and 625 are designed to ultra high standards over 260 min tensile strength, re-spectively.



## BOLTS

PART NO.	BOLT TYPE	RECOMMENDED STRETCH	TORQUE & ANGLE
BLT007	3/8 - Oliver/ARP 2000 Rod bolt	.0050" to .0054"	25 lb/ft + 42 deg
BLT008	3/8 - Oliver/ARP 3.5 Rod bolt	.0052" to .0056"	30 lb/ft + 42 deg
BLT005	7/16 - Oliver/ARP 2000 Rod bolt	.0053" to .0057"	30 lb/ft + 42 deg
BLT030	7/16 - Oliver/ARP L19 Rod bolt	.0053" to .0057"	30 lb/ft + 44 deg
BLT003	7/16 - Oliver/ARP CA 625 Rod bolt	.0063" to .0067"	30 lb/ft + 54 deg

**DO NOT USE METAL STAMPS TO NUMBER RODS.** Metal stamps may disturb the roundness of the rod bore. Paint tool-maker's layout dye on the rod and cap, then inscribe numbers.

**NEVER** use bolts to draw down the rod. Locate cap dowel sleeves into the counterbores of the rod. Then, **CAREFULLY** tap cap into place.

**CLEAN** all parts thoroughly to remove all dirt and foreign oils. Spread Oliver bolt lube on the threads and under head of bolt and tighten per instructions below.

**BEFORE** bolting the oil pan on, set a torque wrench at 50 lb/ft for 7/16 bolt (40 lb/ft for 3/8 bolt, 30 lb/ft for 5/16 bolt), and check all rod bolts. If any bolt turns before reaching the preset torque, it has not been properly tightened. You must loosen these bolts and tighten them properly.





# Ordering Procedures **PART NUMBERING SYSTEM**

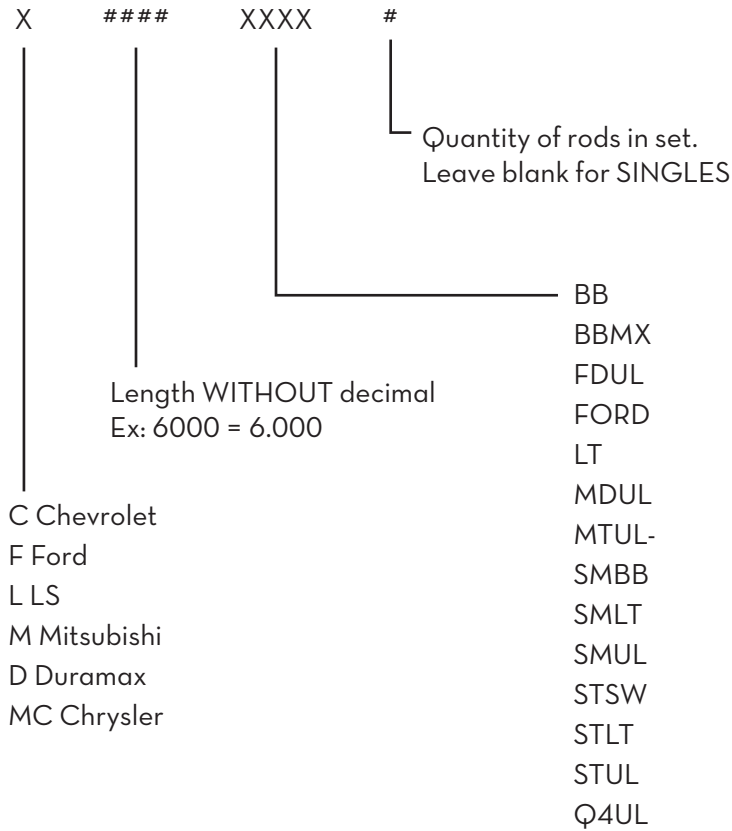

- C Chevrolet
- F Ford
- L LS
- M Mitsubishi
- D Duramax
- MC Chrysler

Length WITHOUT decimal  
Ex: 6000 = 6.000

ex: **C5700STLT8**  
**C** - CHEVROLET  
**5700** - 5.700"  
**STLT** - STANDARD JOURNAL LIGHT  
**8** - QUANTITY OF RODS IN SET

## Custom Rod Specification and Ordering

Call Oliver Racing Parts at (231) 4515 or EMAIL to [sales@oliverracingparts.com](mailto:sales@oliverracingparts.com),  
 or use the convenient ONLINE form at [www.oliverracingparts.com](http://www.oliverracingparts.com)

MADE IN USA   
 • **SINCE 1983** •



*Joe Moch, President and CEO*

# **OLIVER**

RACING PARTS

# **OLIVER**

## RACING PARTS

**MADE IN AMERICA**

RESPECTED AROUND THE WORLD



**OLIVER RACING PARTS**

5339 M66 North

Charlevoix, MI 49720

Office: (231) 237-4515

[www.OliverRacingParts.com](http://www.OliverRacingParts.com)

**CRAFTSMANSHIP • PRECISION • DURABILITY • STRENGTH**

SALES@OLIVERRACINGPARTS.COM • [WWW.OLIVERRACINGPARTS.COM](http://WWW.OLIVERRACINGPARTS.COM) • (231) 237 - 4515