

A-Arms (front) 33 & 35
 Access door kits 89
 Accusump oil accumulator kits 69
 Accusump oil accumulator mounts (dragster) 69 & 92
 Adjustable proportioning valves 57
 Air Bottles & Air Pump System 69
 Air Bottle clamps 69
 Alcohol Funny Car Bodies 94
 Alternators 65
 Alternator mount kits 65
 Anti roll bars 14, 38, 39, 40 & 46
 Axles 53
 Axle bearings 54
 Back brace - 9" Ford 52
 Bantam body 94
 Battery cable kits 64
 Battery disconnects 64 & 92
 Battery mounts 64
 Batteries 64
 Body front end mount kit 32
 Books and videos 96
Brackets and Tabs 79 - 83
 Brake calipers 57
 Brake fluid 57
 Brake handles 58 & 59
 Brake line disconnect 57
 Brake pads 57
 Brake pressure gauge 57
 Brake proportioning valve 57
 Brake kits 55 & 56
 Cables & accessories 67
 Camaro Bolt-In front "K" members & components 35
 Camaro Bolt-In frame connectors & rear suspension components 38 & 39
 Camaro (67-69) rack & pinion mount kit 36
 Camaro roadster body 94
 Camera Mounts 29
 Carbon fiber repair kits 94
 Carburetor accessories 78
 C-Clip eliminators 54
 Center sections & components, 9" Ford 54
 Chassis blueprints 30
 Chassis kits 86
 Chassis stabilizers 73
 Chevy II bolt in front frame & strut package 35
 Chump Car roll cage 23 & 24
 Chrome coil over spring 48
 Clamps, chassis 74
 Cleco kits 13
 Clevis ends 74
 Cockpit lights 91
 Coil mounts 81 & 92
 Coil over shock kit - S&W 48
 Coil over shocks - QA-1 50
 Coil over shocks - Strange 49
 Cooling system components 68 & 91
 Couplers 62
 Crossmembers - 2"x3" 20 & 45
 Dashboard kits 22 & 90
 Delay box mount kit 66
 Delay boxes 66
 Dial In Board mounts 89
 Dial In Marker 73
 Diapers 72
 Door handle kit - inner 32
 Door hinge kit 32
 Door panel kits 22
 Door pull kits 22
 Door strap kits 22
 Door window frame kit 32
 Door window latch kit 32
 Dragster adjustable pedal mounts 90
 Dragster adjustable throttle kit 90
 Dragster battery hold down 93
 Dragster belly pan kit 92
 Dragster cockpit tunnel 91
 Dragster coil mounts 92
 Dragster dashboards 90
 Dragster deflector plate 92
 Dragster drive shaft 92
 Dragster electrical disconnect kit 92
 Dragster Fiberglass & CarbonFiber bdy 88
 Dragster flip up tow hook kit 88
 Dragster (nostalgia) front axle 93
 Dragster floor & foot box bulkhead kit 90
 Dragster front tires 76
 Dragster fuel cell mount kit 93
 Dragster ignition panel 93
 Dragster nitrous bottle mount 92
 Dragster noses - fiberglass 88
 Dragster nose - trailer hanger 88
 Dragster quick jacks 93
 Dragster radius rod kit 93
 Dragster roll bar padding 90
 Dragster seat belt hooks 90
 Dragster seats 90 & 93

60th Anniversary VOLUME 35 Table of Contents

Monte Carlo Alcohol Funny Car body window kit 95
 Motor plates - Funny Car & Altered 95
 Motor plates - Dragster 93
 Motor plates - front 60
 Motor plates - mid mount 61
 Motor plate mounts 60
 Mustang Alcohol Funny Car body 94
 Mustang bolt on anti roll bar 46
 Mustang bolt in front suspension 33
 Mustang bolt in frame connectors rear suspension components 40 - 44
 Mustang rear control arm stiffening kit 41
 Mustang II front frame & suspension 34
 Neck collars 70
New Product Showcase 2-5
 Nova (68-72) rack & pinion mount kit 36
 Off Road Ladder Bars 45
 Offset leaf spring hangers 45
 Oil accumulators 69
 Oil accumulator mounts (dragster) 69 & 92
 Panhard bars 47, 38-40
 Parachutes, cable kit & mounts 71
 Pedals assemblies 58 & 59
 Pedal Ratio Explained 'Tech Tip' 58
 Pinion center locator plates 53 & 13
 Pinion yokes 62
 Pro/Street rear runner kits 29
 Promotional Items & S&W Collectables 96
 ProWerks Fuel Cell Caps 77
 Pyrometers 73
 Quarter turn fasteners 75
 Quarter turn fastener tools 13 & 75
 Quick pins 75
Race Cars by S&W
 Pro-Touring & Pro-Street 10
 Altered 8
 Comp Eliminator 7
 Top Dragsters 7
 Dragsters - Solid or Swing Arm 6
 Dragsters - Nostalgia & Front Engine 10
 Full Bodied Cars 7
 Funny Cars 93
 Funny Cars - Nostalgia 10
 Roadsters 8 & 9
 Rack & pinions 36 & 37
 Radiators 68 & 91
 Ranger Ladder bar kit 47
 Rat Rod Ladder bar system 14 & 47
 Rear axle housings - Ford 51 & 52
 Rear axle housing - bolt in 82-02 Camaro - 9" Ford 38 & 39
 Rear axle housing - bolt in 05-14 Mustang - 9" Ford 40
 Rear axle housings - Strange S60 52
 Rear axle housings - 12 bolt 52
 Rear support covers 53
 Rear suspension packages 42, 47
 Receiver covers 96
 Residual pressure valves 57
 Rod end seals 75
 Rod ends 75
 Roll bars and roll cages 23 - 29, & 87
 Roll bar and roll cage accessories 29
 Roll bar to cage conversions 23 - 24
 Roll cage gussets 29
 Roll control 57
 Sander Engineering wheels 76
 S-10 Steering shaft kit 19
 Scales 69
 Scoops & scoop mounts 89
 Scoop filters 89
 Seats 73, 90 & 93
 Seat belts 70
 Seat mount kit 73
 Shifters & accessories 67
 Shifter mount - door car 67
 Shock crossmembers 48
 Shock mounting fixture 13
 Shock mounts 48
 Shock spanner wrench 48
 Shock thrust bearing kit 48
 Shock tower brace 40
 Shocks & springs 48 - 50
 Solid rod ends 75
 Spark plug wires 65
 Spindles 36 - 37
 Spoilers / Wings 19 & 32
 Spool bearings 54
 Spools 54
 Springs - coil over 48
 Starters 65
 Steering boxes - altered / funny car 37
 Steering column kits 36
 Steering column support 36
 Steering dampner kit 95
 Steering disconnects 36
 Steering U-Joints & adapters 36
 Steering wheels 36 - 37

Street Rod 4 Bar 47
 Struts 33
 Struts & strut front frame packages 33
 Subframe connectors - bolt on 21, 38-44
 Suspension components
 Front suspension components 33 - 35
 Camaro bolt-in
 Front suspension components 35
 Rear suspension components 45 - 50
 Camaro bolt in rear 38-39
 Mustang bolt in front 35
 Mustang bolt in rear 40 - 44
 Swarr Bars 40 & 41
 Sweatshirts 96
 Swing out side bar kit 29
 Switch panels 65
 T-Shirts 96
 Tail lights 65
 Tape - ISC Racer's Tape 73
 Taps 13
Terms and conditions of sale Inside rear cover
 Threaded tube ends 74
 Throttle cable mounts 78
 Throttle pedal mount kit 58
 Throttle stops, launch controllers & timers 66
 Tie downs 73
 Tire pressure gauges 73
 Tire screw template & screws 13
 Tires and accessories 76
 Tools 13, 46, 48, 53, 69, 73 & 75
 Torque arms 38 & 39
 Torsion bar assemblies - front 34 & 93
 Tow hook kits 68 & 88
 Track locator bars 47
 Trans brake buttons 64
 Trans brake button mounts 37
 Transmission adapters 59
 Transmission blankets 71
 Transmission coolers 68
 Transmission crossmembers 20
 Transmission handles 91
 Transmission limiters 91
 Transmission overflow tank & handle 91
 Transmission shields 71
 Transmission slip yokes 62
 Truck & SUV roll bars 28
 Tubing 30
 Tube notchers 13
 Ultimate ladder bars 45
 Unwelded rear frame packages 20
 Upholstery 90
 Vacuum pumps 66
 Valve spring pressure tester 13
 Video Camera mounts 29
 Videos and Books 96
 Water pumps & accessories 68
Warranty Disclaimer/Shipping Inside Rear Cover
 Welded rear frame packages
 Ladder Bar - 2 x 3 - Round Tube 15
 4-link - 2 x 3 15
 4-link - Pro-500 round tube 14
 55-56-57 Chevrolet 16
 64-72 Chevelle/Monte Carlo 17
 67-69 Camaro 4-Link 16
 68-72 Nova - 4 Link 16
 68-72 Nova - Ladder bar 16
 78-83 Malibu / 78-88 Monte Carlo - 4-Link 17
 78-83 Malibu / 78-88 Monte Carlo - Ladder Bar 17
 79-93 Mustang - 4 Link 18
 79-93 Mustang - Ladder Bar 18
 82-02 Camaro/Firebird - 4 Link 18
 82-02 Camaro/Firebird - Ladder Bar 18
 88-95 Chevy C-1500 short bed pickup 19
 S-10 Chevy pickup - Ladder Bar 19
 S-10 Chevy pickup - 4-Link 19
 Weight bars 92
 Welding wire 87
 Wheel cradles 73
 Wheel spacers 83
 Wheel studs 54
 Wheel tubs 22
 Wheels & tires 76
 Wheelie bars 14, 31, 39
 Wheelie bar wheels 30
 Weld bungs 74
 Window mounting kit 29
 Window nets & mounts 29
 Windshield support kit 32
 Wishbone kits 14 & 47
 Wings and wing mount kits 87 & 93

Look for S&W's 'Signature Orange' Track Side Display Tent!

Stop by to meet us and view new products, test interactive displays, purchase tech inspection needs and take home a new catalog.

Shop for SHOW SPECIALS and Sign Up for Giveaways between rounds.

Our display event schedule will be posted in swracecars.com news and on all social media pages @SWRACECARS S&W backs up every sale with one of the most knowledgeable Sales and Tech Support Departments in Racing.

Most importantly, S&W is a racers' company.

When the Work Week is Done...We GO Racing!



Steering Shaft Support Kit w/Bushings

Works with 3/4" and 7/8" steering shafts, weld to 1-3/8" frame rail. Great for alteredds, front engine dragsters & funny cars. Hardware included. Bushing colors: White, Blue, Red, Orange, Gray, Black. Custom colors are optional.



P/N
35-365

Steering Shaft Support Kit with Bushings

Carbon Fiber Tube Protectors

Carbon Fiber Tube Protectors - 59" Long - Sold Each

P/N

95-780

Fits 1-1/4" to 1-1/2" Diam. Tube

95-781

Fits 1-3/4" to 2-1/4" Diam. Tube

95-782

Fits 1-5/8" to 2" Diam. Tube



Ultra Small Headlight

Black ULTRA SMALL headlight with base - 3.5oz. - 2" front to back, 1.33" diameter. Sold Each

P/N

85-270

Black ULTRA SMALL Headlight



Butterfly Steering Wheel w/3D Printed Plastic Color Grips

The new wheel shares the same size, shape and material as their popular polished butterfly wheels, to maintain structural integrity. Each steering wheel is waterjet cut from 3/16" thick aluminum and measures 7" deep x 8" wide. They are formed and tumbled to provide a uniform surface and smooth edges. Owners can apply a finish that best fits their personal style/theme, or they may choose to keep the natural bare aluminum appearance. The durable 3D Printed plastic grips are pre installed using 10-32 screws, and offered in your choice of Orange, Gray, Red, Blue or Black. They also feature holes for mounting a 4 bolt pattern steering disconnect. Available options include: Custom grip colors and button mounts - see pg.37.



P/N

35-256 Butterfly Wheel w/Orange Grips

35-251 Butterfly Wheel w/Gray Grips

35-254 Butterfly Wheel w/Red Grips

35-253 Butterfly Wheel w/Blue Grips

35-255 Butterfly Wheel w/Black Grips

CALL Custom Colored Grips



BARE Butterfly Steering Wheel

P/N

35-250 Bare Butterfly Steering Wheel
Tumbled finish. Grips not included.



Color 3D Printed Plastic Grip Sets

3-D printed plastic replacement grips for S&W Butterfly Steering Wheel. Five standard colors available. Set includes two front grips with S&W logo and two rear grips tapped for 10-32. Hardware Included. Optional custom colors are available.

Note: Grip front half's & back half's are available separately. Please contact us by phone, email or messenger.

NEW PRODUCT SHOWCASE

Seat Belt Pull

Slips into loop at end of belts. Works on 2" & 3" belts. 1/4" aluminum tumbled finish.



P/N
75-601
Seat Belt Pull

Chassis Cable Guides

Steel cable guides are available as single, double or triple. Add -1, -2 or -3 to end of P/N.

P/N
60-125 Welds to 1-1/4" Diam. Round Tube
60-100 Welds to Flat Surfaces & 2x3 Flats



Reinforcing Ring for Fuel Caps

Works w/S&W branded caps & PRO-WERKS caps. 1/4" th. alum. 2-piece ring w/1/4"-20 tapped holes. (6 hole avail.)

P/N
80-001
12 Bolt Fuel Cell Cap Reinforcing Ring



Non S&W Chassis MFG. Tag

Non S&W Made Chassis MFG. Tag.

P/N
05-CUSTOM-TAG
Non S&W Chassis Tag



Header Collector Bezels

Stainless Steel .050" thick Header Collector Bezels. Mill Finish, Includes (2) Bezels, Stainless Steel Hardware. Three sizes available.



Ask Us About Custom Shapes & Sizes.
Call 1-800-523-3353

P/N
95-094 Collector Bezel Kit for 4" Collector/5" Hole
95-095 Collector Bezel Kit for 4.5" Collector/5.5" Hole
95-096 Collector Bezel Kit for 5" Collector/6" Hole



Bottle Clamps

Aluminum bottle clamps are 1/2" thick with cinch for clamping bottle. Includes hardware.

P/N
95-8245 Fits 4-3/8" Diam. Bottle to 1-5/8" Diam. Tube
95-8246 Fits 2" Diam. Bottle to 1-5/8" Diam. Tube
95-8247 Fits 5-1/4" Diam. Bottle to 1-5/8" Diam. Tube



Ladder Bar Jam Nut Wrench

Designed to fit between the safety bracket on the front of S&W ladder bars. Fits 1-1/8" hex nut. 3/8" thick steel, Tumble finish.

P/N
90-045
Ladder Bar Jam Nut Wrench



9.25lb. Lead Weight Puck

Solid Lead, 2" thick, 4" Diam. with 1/2" hole in center. 9.25 lbs.

P/N
90-029
9.25lb. Weight Puck



Race Car Push Bar Kit

Group's new 60" race car push bar kit will allow race teams to safely navigate their car through crowded pit lanes.

It's made of 1" x .065" wall mild steel tubing with welded tube ends. All mounting hardware is included; (1) quick pin, (2) 1/2" rod ends, (2) bolts with nuts, (2) half moons, (1) weld on u-bracket for the push vehicle and (1) weld on u-bracket for the race car.

All components are shipped bare; ready for the your preferred finish.

Prevent damage that can occur, while towing to the staging lanes and returning to your pit space. It will add stability & control for you and your teammates.

P/N
75-811
Push Bar Kit Complete
75-811U
Push Bar
Extension Kit (adds 3 ft to 75-811)



CALL for Pricing & Availability

See our full line card featuring over 50 quality brands on page 11



1979-1993 Carbon Fiber Mustang Hatchback Spoiler

Specifically designed for the 79-93 Mustang hatchback, the carbon fiber spoiler comes with all necessary hardware and 2 spoiler support rods. Spoiler is 54" wide and extends 14" off the back of the car. Also available in aluminum.

P/N
95-706
79-93 Carbon Fiber Mustang Hatchback Spoiler Kit





C7 Corvette, Roadster and Bantam Bodies are NOW AVAILABLE



Carbon Fiber and Fiberglass. High Quality Surface Finish Straight from the Mold. **CALL for Details**



**RACE CARS - CUSTOM RODS - PERFORMANCE STREET
NEW // UPGRADES // MAKE-OVERS**

Get Started with a Chassis Kit or Order a "Turn-Key" Race Ready Car/Truck

Ask About S&W's Chassis Swap Program



Alcohol Funny Cars | Dragsters | Door Cars
Roadsters | Altered | Street Rods | Rat Rods
Customs | Pro Street | Pro Touring
AA & BB Nostalgia Dragsters & Funny Cars
Drift | Road Racing | Off Road | 4X4 | UTV

Walt Woney, Jim Amole & Team in NHRA INDY Victory Circle with their S&W built dragster and crew. WINNER 1967 NHRA National Event at Indianapolis

**S&W will make sure Your Car Meets or Exceeds Current Sanctioning Body Specifications
We can Schedule On-Site NHRA Chassis Certifications.**



Do You Have Tough Questions? We will help you find the answers!
Call TOLL FREE and Visit our New & Improved multi-device user friendly website

**Web Site: SWRACECARS.com OPEN 24Hrs a Day
Phone: 1-800-523-3353 M-F 8am-6pm EST**



Bill Phillips / HHP Motorsports S&W built C7 Vette WINNER 2019 NHRA National Open Best Engineered Vehicle and Best Appearing Car at Atco Dragway.



STEP-by-STEP Building System

S&W's STEP-by-STEP Building System is Easy to Follow. "It Takes the Guess-Work Out"

#1
TECH
SUPPORT
Monday - Friday
8am-6pm EST

STEP#1

Start with a Straight Foundation!

Universal Welded Lower Frame Kit Includes:

- Choose from (3) Front A-Arm Hub-to-Hub Widths to best suit your application. Widths: 52-3/16" // 55-3/16" // 58-3/16" (Front Crossmember will be welded in)
- Your Choice of 4-Link or Ladder Bar Rear Frame configuration ~ to best suit your application. Widths: 24" // 26" // 28" (Incl. 4L or LB Hardware Kit)
- Choose your Wheel Base Length
4-Link up to 115" Max. Length / Ladder Bar up to 127" Max. Length
- Jig Welded Frame guarantees your build will start Straight & Square. (MIG Welded Mild Steel ~ Easy to add on at home)
Includes: Body Mounting Plates, Outriggers & Driveshaft Loop.

P/N 36-997
STEP #1
Bare Welded
Frame



DRAGZINE
Tech Story:
Building Your
Own Chassis
with S&W

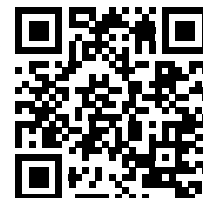

STEP#2 Front Suspension, Brakes & Steering

- Your S&W Sales Representative will help you choose the best Front Suspension System for your Street or Strip needs. AJE, Flaming River MW, Grant, ProWerks, Wilwood, Strange & Aerospace.



STEP#3 Rear Housing, Rear Suspension & Brakes

- S&W offers many Rear Housings, plus Suspension & Brake packages from QAI, Strange, Moser, MW, Wilwood & Aerospace.



The Best Way
to End Straight,
is to **START STRAIGHT!**



Ready for
Bolt-On's
Using Basic
Hand Tools
at Home!

21
Front End
& BackHalf
COMBOS

STEP#4 & Beyond

- Roll Bar or Roll Cage. Tabs & Brackets for body mounting and on & on until your project is complete.

Monday-Friday 8am-6pm EST TOLL FREE 1-800-523-3353



social @SWRACECARS

website SWRACECARS.COM

CUSTOM BUILT RACE CARS

CHAMPIONSHIP QUALITY

Serving Racers Since 1959

PRO SERIES DRAGSTERS

Earn More \$\$\$
with the NEW CAR CONTINGENCY PROGRAM

Have Questions?
Need a Quote?
Call Randy ext.115

ASK US ABOUT NEW' CAR
Innovations 'Trick' Upgrades!



Randy Krause 2X NHRA-Division 1 Bracket Finals Champion - Super Pro

If you take your Sportsman or ET Series racing as seriously as the pros do, you need an S&W Pro/Series Dragster! The S&W Pro/Series Dragster is the result of years of extensive on-track testing and in-house development. The S&W commitment to quality & performance assures you of a championship quality chassis with unsurpassed repeatability & consistency. Just as each class of racing has its own requirements, each dragster chassis has its own special requirements. A chassis for Super Comp or E.T. Brackets has to work differently than a chassis for Top Dragster or Top Fuel. Every S&W dragster is specifically built to provide the best possible chassis for your type of racing. Engine location, cockpit layout and driver comfort are critical to building a championship quality race car that is right for you. If you're serious about winning, "off-the-rack" race cars just don't cut it. Step up to the hand-crafted quality & performance of the choice of champions, step up to S&W Race Cars.



Dave Long & Team

COMPLETE WELDED CHASSIS with Body

Every S&W dragster, regardless of class, is built to current NHRA / IHRA specifications. The S&W Pro/Series dragster is ideal for Super Comp, Quick Rod or E.T. Brackets.

• Solid Mounted Rear Housing

- 225" wheelbase rear engine chassis
- Strange aluminum 9" Ford housing
- Streamline front end • Billet spindles
- Billet rack & pinion • Polished aluminum steering wheel
- All steering linkage, tie rods, rod ends, and steering column
- Brake pedal and master cylinder mount
- Brake line installation slots and mounting tab
- Throttle pedal with adjustable stop
- Parachute lever and hardware • Parachute mount and anchor
- Custom aluminum dash with all cut outs • Shifter mount
- Fuel cell mount • Battery tray and hold down
- Aluminum ignition panel • Rear end anti-rotation device
- Aluminum motor plate and motor mounts
- Tail light and mount • Master disconnect and mount
- Ground studs on chassis • Lightweight Dzus button tabs
- 1/8" aluminum firewall between engine and driver
- Grade 8 hardware • Weight bar mounts in nose
- Custom body from front to rear tires
- Aero lip on bottom of body
- Fiberglass nose (3 models to choose from)
- Aluminum floor pan, and front firewall
- Pro/Glass windshield (clear or tinted) • Helmet hook
- Carbon fiber seat with seat belt slots • Seat belt hooks
- Integral seat belt mounts • Entry / exit assist handles
- Manufacturers tag on chassis
- Chassis will meet certification specs

• Swing Arm Rear Suspension

- 235" / 245" & 255" wheelbase rear engine chassis
- Strange aluminum 9" Ford housing
- Chrome moly housing brackets
- Complete 4-link or swing arm • (8) 4130 chrome moly rod ends
- Torsional anti-roll bar • Adjustable lower shock mounts
- Strange aluminum double externally adjustable coil over shocks
- Custom matched coil over springs
- Streamline front end • Billet spindles
- Billet rack & pinion • Polished aluminum steering wheel
- All steering linkage, tie rods, rod ends, and steering column
- Brake pedal, master cylinder and mount
- Brake line installation slots and mounting tab
- Throttle pedal with adjustable stop
- Parachute lever and hardware • Parachute mount and anchor
- Custom aluminum dash with all cut outs • Shifter mount
- Battery tray and hold down • Aluminum ignition panel
- Fuel cell mount • Aluminum motor plate & motor mounts
- Tail light and mount • Master disconnect & mount
- Ground studs on chassis • Lightweight Dzus button tabs
- 1/8" aluminum firewall between engine and driver
- Grade 8 hardware • Weight bar mounts in nose
- Custom body from front to rear tires
- Aero lip on bottom of body
- Fiberglass nose (3 models to choose from)
- Aluminum belly pan, and front firewall
- Pro/Glass windshield (clear or tinted)
- Carbon fiber seat with seat belt slots • Seat belt hooks
- Integral seat belt mounts • Helmet hook
- Entry / exit assist handles • Manufacturers tag on chassis
- Chassis will meet certification specs

We can supply you with Tubing & Blueprints, a Roller or a "Turn-Key",
Race Ready Car...or anything in-between!

CUSTOM BUILT RACE CARS

CHAMPIONSHIP QUALITY

Serving Racers Since 1959

TOP DRAGSTER & COMP ELIMINATOR

If Top Dragster or Competition Eliminator is your thing, S&W Race Cars can build you a funny car, dragster, roadster or door car to fit your chosen class!



Bill Hardifer and the HHP Motorsports Team

TOP ALCOHOL FUNNY CARS



Hand-crafted for optimum strength and driver safety, S&W funny cars are designed for maximum reliability and ease of maintenance. All S&W funny car chassis are jig constructed and TIG welded to conform to current NHRA & IHRA safety specifications. S&W can build you a basic chassis or supply a complete rolling race car like those of 1992 NHRA/Winston Top Alcohol Funny Car World Champion, Bob Newberry, 1995 NHRA/Winston Top Alcohol Funny Car World Champion Joe Penland Jr., 1993 & 1995 IHRA Top Alcohol Funny Car World Champion



Todd Paton or 1996 NHRA Winston Top Alcohol Funny Car World Champion, Tony Bartone. When it comes to Alcohol Funny Cars nobody does it better than S&W Race Cars. In 1996, Tony Bartone's incredible consecutive round win streak came at the wheel of his S&W built Alcohol Funny Car. In 2000, Scott Weny won the IHRA Pro/Funny Car World Championship at the wheel of Ken Sheetz's beautiful S&W Race Cars built Corvette Funny Car. In 2005, S&W, Bob Newberry & Roush Composites collaborated on the first ever, alcohol only funny car body. That body installed on an S&W chassis helped Bob Newberry win his second alcohol funny car championship in 2005 and has become the most used body in the class.

Because of the ever changing technology in Alcohol Funny Car racing and the wide range of options available, please call Randy ext.115 for current pricing.

FULL BODIED RACE CARS

S&W Race Cars built the first tube chassis Pro/Stock, Bill Jenkins' 1972 Vega. From that time, S&W has continually improved on that design so that we can provide our customers with the latest in doorslammer chassis technology. S&W offers these chassis in either mild-steel or 4130 chrome-moly and each chassis, regardless of material, is hand fabricated on our Pro/Stock chassis jig. All chassis are custom built, one at a time, for the buyer's individual class and body style requirements. Full bodied cars are available in any stage of completion, from a bare welded chassis, to a complete rolling race car, needing only your motor and transmission. S&W can build a chassis inside your existing body shell or provide you with a complete fiberglass or steel & fiberglass body. S&W full bodied car chassis are available with ladder bar or 4-link rear suspension and your choice of strut or A-arm front suspensions. Although designed for Pro/Stock competition, these chassis provide the ultimate in full bodied Super Class or E.T. Bracket competition. All chassis are built in accordance with current NHRA chassis specifications. Due to the large number of options and variables involved in building a full bodied race car, please call S&W for current pricing.



Paul Burruss



social @SWRACECARS

website SWRACECARS.COM

CUSTOM BUILT RACE CARS

CHAMPIONSHIP QUALITY

Serving Racers Since 1959

CAMARO ROADSTER

Perfect for Super Gas, Super Rod or E.T. Brackets the S&W Camaro roadster has quickly become the favorite of the "red bowtie" bunch. The S&W Race Cars' Camaro roadster is available in kit form or in any state of completion, from a bare welded chassis to a complete rolling race car. The S&W Camaro roadster is built to meet or exceed all current NHRA & IHRA chassis specifications. The S&W Camaro roadster is intended for drag race use only and is not

Because of the "custom built" nature of our cars and wide range of options available, please call Randy ext.115 for current pricing.



Ryan Baudoin

BASE CHASSIS

Base Chassis - includes; Jig-assembled & TIG welded, 4130 chrome-moly, chassis to SFI spec • Manufacturers tag • All suspension mounts • Lower A-arms • Wilwood rack and pinion • Frame mounts & mid motor plate for big & small block Chevy • Front motor plate for big or small block Chevy • Transmission crossmember (glide) • Swing arm with all mounts & moly rod ends • Torsional anti-roll bar package • Strange aluminum housing • Upper & lower shock mounts • Tie down loops & tow loop.

COMPLETE WELDED CHASSIS with Body

Includes everything listed above plus: Torsional anti-roll bar package • Steering column with Grant steering wheel & quick disconnect Throttle pedal • Brake pedal & master cylinder mount • Fuel cell mount • Trans cooler mount • Battery mount • Shifter mount • Dash panel • complete Camaro body • Mount body & nose • Aluminum seat • Aluminum interior • Rear spoiler package • Parachute lever, hardware & anchor

COMPLETE ROLLING CHASSIS & Body

Includes all of the above plus; Strange struts with springs & medium brake kit • Chrome wheelie bar with orange Wheelz wheel • Master disconnect switch mount • Lateral engine limiters (pair) • Aluminum radiator • Aluminum shroud & electric fan • Radiator mount • Helmet hook • Seat belt hooks • Small air bottle mount • Fuel pump mount • American Racing Torq-Thrust front wheels & bearings (pair) • American Racing Trakstar rear wheels (pair) 15" x 15" • Goodyear 15" front tires D2981 (pair) • 25" Goodyear rear tires (pair) 33.0" x 17.0"-15" • Mount tires (4) & Balance, valve stems • Drill rear wheels for screws - includes screws • Strange 35 spline axles with 5/8" stud holes (pair) • 5/8" axle studs & lug nuts (set) • Axle bearings (pair) • Assemble axles (pair) - press 2 bearings & install stud kit • Roadster Hood scoop • 4 Gallon fuel cell #10 outlet, # 8 return, # 6 vent • Strange dual master cylinder • Strange rear brakes with slotted rotors • Brake lines installed for 4 wheel brakes with line lock solenoid and billet proportioning valve • Tie down loops & tow loop

ALTEREDS



Optional Hand-Formed
Custom Aluminum Altered Body

The S&W altered is an ultra trick, multi-class race car, designed and fabricated to be consistent enough for E.T. racing, yet versatile enough for Competition Eliminator. Each S&W altered chassis is constructed to accommodate the racer's individual needs and requirements. All S&W altered chassis are jig-assembled and TIG welded to conform to current NHRA specifications. S&W altered are available in kit form or in various stages of completion.

3 Body Styles Available:

BANTAM / T-BODY & Custom Aluminum
(View More on Pg.94)

125" SUPER/CLASS COMPLETE WELDED CHASSIS

*125" wheelbase, precision jig assembled, TIG welded, 4130 chrome moly chassis
6 point roll bar • "A" frame front end • SPE steering box • Spindles • All steering linkage, tie rods and rod ends
Steering column with polished wheel • Brake pedal • Master cylinder mount • Throttle pedal with adjustable stop • Front motor mounts • Mid motor plate • Transmission crossmember • 9" Ford rear housing • Parachute mount • Shifter mount • Tow loop • Ladder bar or solid rear suspension (4-link optional at extra cost) • Rear suspension wishbone • Strange aluminum adjustable coil-overs with springs • Aluminum seat with seat belt slots • Integral seat belt mounts • Parachute lever and hardware • Tach and gauge panel • Battery tray • Fuel cell mount • Manufacturers Tag*

COMPLETE WELDED CHASSIS with Body

Includes everything listed above plus - your choice of 23T or 32 Bantam body mounted with all aluminum work in body

150" ADVANCED E.T. ALTERED - BASE CHASSIS

*150" wheelbase, precision jig assembled, TIG welded, 4130 chrome moly chassis
• 6-point roll bar • Solid front end • Spindles & steering box • Steering column • Polished steering wheel • All steering linkage, tie rods, & rod ends • 4-link rear suspension with anti roll bar
Strange alum. housing • Strange double adjustable coil over shocks & springs
Parachute lever & hardware • Master cylinder mount • Throttle pedal with adjustable stop
Brake or clutch pedal • Tach & gauge panel • Motor mounts & motor plate • Tow loop
Aluminum seat with seat belt slots • Integral seat belt mounts • Manufacturers Tag*



Mike Nickerson

CUSTOM BUILT RACE CARS

CHAMPIONSHIP QUALITY

Serving Racers Since 1959

ROADSTERS

Designed specifically for ET Brackets, Super/Gas, & Super/Comp, S&W roadsters are for the racer desiring the feel of a full bodied race car and the added visibility of an open cockpit car. By applying years of racing experience and on track testing, S&W has been able to develop a strong, dependable quality race car that is also quite affordable. S&W Race Cars' roadsters are available in kit form or in any state of completion, from a bare welded chassis to a complete rolling race car. All S&W roadsters are built to meet or exceed all current NHRA & IHRA chassis specifications. S&W roadsters are intended for drag race use only and are not suitable for street use!!

Because of the "custom built" nature of our cars and wide range of options available, please call Randy ext.115 for current pricing.

38' CHEVY or CORVETTE ROADSTER WELDED CHASSIS

- Precision jig assembled, TIG welded, 4130 chrome moly chassis • Manufacturer's tag
- All suspension mounts • Lower A-arms (pair) • Wilwood rack and pinion
- Frame mounts for big & small block Chevrolet • Mid motor plate
- Front motor plate for big or small block Chevrolet (your choice)
- Powerglide transmission crossmember
- Laser/link 4-link with all mounts and 4130 chrome moly rod ends
- Wishbone track locator • Fabricated 9" Ford rear housing
- Upper & lower adjustable shock mounts



38' CHEVY or CORVETTE ROADSTER COMPLETE CHASSIS with Body

Call for Details



Alan & Jason Kenny



Brent McKinney

AERO ROADSTER WELDED CHASSIS

- Precision jig assembled, TIG welded, 4130 chrome moly chassis • 115" Wheelbase • Front torsion bar • Custom front axle • Spindles • Tie rods and rod ends
- SPE rack and pinion • Frame mounts for big & small block Chevrolet
- Mid motor plate • Front motor plate for big or small block Chevrolet (your choice) • Powerglide transmission crossmember • Laser/link 4-link with all mounts and 4130 chrome moly rod ends • Wishbone track locator • Fabricated 9" Ford rear housing • Torsional anti-roll bar • Tie down loops
- Manufacturer's tag

AERO ROADSTER COMPLETE CHASSIS with Body

Call for Details



Scott Wency

225" TOP FUEL NOSTALGIA FRONT ENGINE DRAGSTERS

S&W's 225" Top Fuel Nostalgia F.E.D is designed and fabricated to be a contender. Each S&W altered chassis is constructed to accommodate the racer's individual needs and requirements. All S&W F.E.D. chassis are jig-assembled and TIG welded to conform to current NHRA specifications. Your front engine dragster can be ordered with Fuel Floater Rear Housing or with 9" Ford or FAB Rear Housing. As with all S&W's USA Made Race Cars, the Top Fuel Nostalgia F.E.D. can be purchased as a roller or complete 'turn-key' certified race car.

225" TOP FUEL NOSTALGIA FRONT ENGINE DRAGSTER WELDED CHASSIS

- SFI chassis specification 2.2 for 5.99 ET and quicker. (6.0 ET and slower available)
- 225" wheel base • Chrome Moly tubing • 28" Front Track Width • 23" Shoulder Hoop (inside measurement) • 6-Point Roll Cage • 1/4" 6061 Aluminum Full Mid Plate (Chrome Moly avail.)
- Front Motor Mount Blanks • Rear Housing Anti-Rotation Device
- Separate Upper & Lower Front Frame Rail Style

225" TOP FUEL NOSTALGIA FRONT ENGINE DRAGSTER COMPLETE CHASSIS with Body

Call for Details

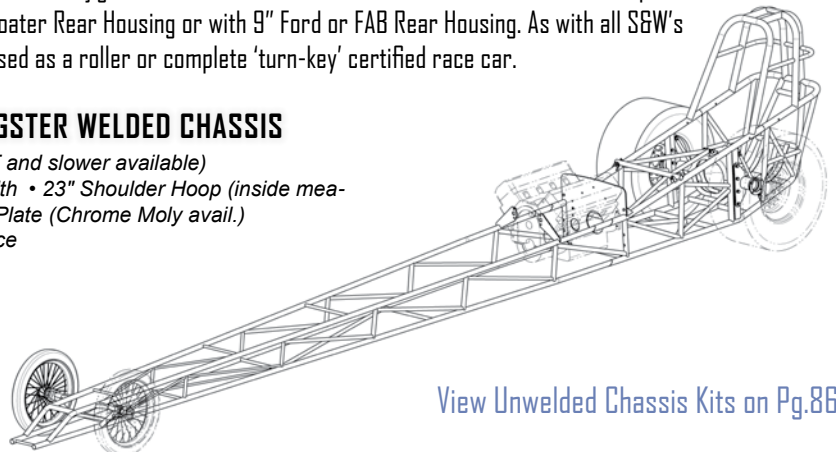

View Unwelded Chassis Kits on Pg.86



social @SWRACECARS

website SWRACECARS.COM

CUSTOM BUILT RACE CARS

CHAMPIONSHIP QUALITY

Serving Racers Since 1959

NOSTALGIA DRAGSTERS



Shown with full body option

WELDED CHASSIS with Body

- 200" wheelbase front engine chassis
- 9" Ford housing with Olds ends • Front axle • Spindles
- Steering box. • All steering linkage, tie rods, rod ends, & steering column • Steering wheel
- Rear end anti-rotation device • Brake pedal or handle & master cylinder mount. • Throttle pedal with adjustable stop. • Shorty aluminum body from seat to front of motor • Belly pan. • Aluminum seat with seat belt slots. • Lexan windscreen for added driver visibility • Aluminum motor mounts & motor plate
- Parachute mount & anchor. • Tail-light / master disconnect switch mount • Manufacturers tag

COMPLETE ROLLING CHASSIS with Body

Our complete rolling chassis includes everything that is listed under a Complete welded chassis - Plus:

- Parachute lever & hardware • Tach & gauge bracket • Shifter mount
- Battery tray & hold down • Fuel cell or Aluminum fuel tank
- Fuel cell or aluminum fuel tank mount • Rear wheels
- Spoke front wheels with bearings • Goodyear front tires
- Goodyear rear tires • Goodyear rear tubes • Mount tires
- Strange axles with 1/2" Axle studs & lug nuts • Axle bearings

Because of the "custom built" nature of our cars and wide range of options available, please call Randy ext.115 for current pricing.

FRAME KITS (F.E. or Rear Eng.)

Shown: 200" wheelbase, front engine dragster chassis kit. Perfect for nostalgia dragster racing. Meets SFI spec 2.4B.



Ed Bliss Jr.

Ask About Our Nostalgia Top Fuel 225" FED



See Page 93 for FED Race Parts

NOSTALGIA FUNNY CARS

If nostalgia drag racing is your "thing" and Funny Cars are your passion, then S&W Race Cars is the place for you!

We've been building funny cars since the inception of the class and our current crop of alcohol funny cars are some of the finest in racing!.

Whether you're building a new "old" car or restoring and updating an original funny car, your first call should be S&W Race Cars. Call Randy at ext.115 today to discuss your new build or restoration.

See Page 94 & 95 for Funny Car Race Parts



Chris & Krista Massarella

PRO STREET & PRO TOURING

Would you rather be cruisin' to the drive-in or the car show and the pro/street look is for you, we can build it! Whether your preference is for early iron, late model muscle or anything in between, it can roll on an S&W Race Cars chassis. Call Randy at ext.115 today to discuss your ideas and requirements.



Brian Lane



The S&W Team

S&W SALES PROMOTIONS & PROGRAMS

Keep UP-to-SPEED with S&W



Look Up, Like, Follow, Share & Subscribe @ **SWRACECARS** on Facebook, Twitter Instagram and Youtube **#SWPERFORMANCEGROUP**

CLICK on this Code with your Smart Phone to Join Our Mailing List

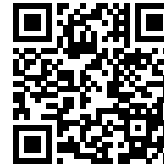

Receive Advance Notice of:

- Sales
- Promotions
- Contests
- Discounts
- New Product Releases

CAR CLUB DISCOUNTS



Does Your Car Club have a Website? 'Cash-In' by teaming up with S&W! Get Qualified and all of your members will receive a 5% Discount on all S&W Made Parts.

WAREHOUSE DISTRIBUTOR PROGRAM

We look forward to incorporating you into our family of W/D's.

- Deep Discounts on S&W Made Parts, Plus Vendor Discounts
- NO Minimum Stocking Orders
- Access to S&W's Unsurpassed Tech Support & Sales Team
- Machine Shop & Fabrication Services WaterJet Cutting, 3D Printing, CNC Turning, Fabricating Custom Tube Bending, Prototypes and Private Label Parts

Please Call 1-800-523-3353 ext.126 for complete program qualifications.

S&W GIFT CERTIFICATES

The perfect gift for the speedy guy or gal on your list!



ANY AMOUNT Starting @ \$25.00

CONTINGENCY PROGRAMS



Sign Up! Winners and R/U's receive receive contingency prizes that are valid toward the purchase of all S&W Made Parts. Read Full Rules on our web site.

LAYAWAY PROGRAM



Ask Us About It!

We will custom tailor a Layaway Plan that's right for you!

S&W's Layaway Plan offers an affordable and painless way to Get Started on Your Next Project.

NewParts, Chassis Kits, Rollers, Complete New Race Cars, Upgrades, Repairs, New 'Nostalgia' Restorations, Etc...

MILITARY DISCOUNTS

Call for Details on our military discount.

LINE CARD

S&W Race Cars & Components Distributes Full Product Lines for:



- AFCC
- AUTOMETER
- AMERICAN RACING WHEELS
- ANTHONY JONES ENGINEERING
- B & M RACING PRODUCTS
- BIONDO RACING PRODUCTS
- BORGESON UNIVERSALS
- C.S.R.
- DIGITAL DELAY
- DELONG MANUFACTURING
- DYNATECH HEADERS
- DZUS FASTENERS
- HAIRY GLASS
- HARWOOD
- HAYDEN ENTERPRISES

- HP BOOKS
- HURST SHIFTERS
- JERSEY GIRL TIE DOWNS
- K&R Performance Engineering
- LAKEWOOD INDUSTRIES
- LAMPLIGHTER PRODUCTIONS
- LENCO EQUIPMENT CO.
- LONGACRE PRODUCTS
- MR. GASKET
- NITROUS WORKS
- OBERG OIL FILTERS
- PHILADELPHIA RACE PRODUCTS
- PENNGRADE 1
- PRO GLASS
- PRO WERKS
- QUIK-LATCH
- RIGGEL'S PERFORMANCE FIBERGLASS
- ROUSH COMPOSITES

- RACEPAK
- SAE
- SEALS-IT ROD END SEALS
- SHAFIROFF RACING ENGINES
- STILETTO PRODUCTS
- STROUD SAFETY
- TAYLOR MOTORSPORTS PRODUCTS
- TCI AUTOMOTIVE
- THERMAL PRODUCTS RESEARCH
- TRZ
- TRANSMISSION SPECIALITIES
- TRAILER TOAD
- TRICK TITANIUM
- VP RACING FUEL
- WILWOOD ENGINEERING



S&W Race Cars is continually adding more lines to service you better. If you don't see something you need in this catalog, please call, it may already be available, either in stock or by special order

1-800-523-3353



social @SWRACECARS

website SWRACECARS.COM

COMBO KITS

Combo #1

PARACHUTE KIT

Combo includes:

- (1) Door Slammer Chute Mount and Anchor
- (1) Release & Cable
- (1) Black Stroud Safety Parachute



for Current Combo Kit Pricing
Call TOLL FREE
1-800-523-3353
or Visit
www.swracecars.com

Combo #6

'ULTIMATE' DRAGSTER STEERING KIT

Combo includes:

- (1) 1" Deep 'Ultimate' Wheel
- (1) Center Button Mtg. Bracket
- (1) 4 Hole Dragster Steering Wheel Quick Disconnect



Combo #2

DOOR CAR STEERING KIT

Combo includes:

- (1) Steering Column Kit
- (1) Mounting Kit
- (1) Grant Steering Wheel



Also Includes Quick Disconnect



Combo #3

PROFILED MOTOR PLATE KIT

Combo includes:

- (1) Profiled Motor Plate
- (1) Mid Plate
- (1) Dual Engine Limiters



Combo #4

STANDARD MOTOR PLATE KIT

Combo includes:

- (1) Profiled Motor Plate
- (1) Mid Plate
- (1) Dual Engine Limiters



Combo #5

COIL OVER SHOCK ADJUSTING KIT

Combo includes:

- (1) Shock Spanner Wrench Set
- (2) Coil Over Thrust Bearing Kits



Johnny Butler



Dale Burrow

Combo #7

FIBERGLASS DOOR INSTALL KIT

Combo includes:

- (Pair) Window Frame Kit
- (Pair) Door Pull Kit, (Pair) Door Panel Kit
- (Pair) Door Hinge Kit
- (Pair) Inner Door Handle Kit



Combo #8

SINGLE BATTERY & INSTALLATION PACKAGE

Combo includes:

- (1) Powermaster S925 12V Battery
- (1) Master Disconnect Switch
- (1) Battery Mount Kit
- (1) Battery Cable Kit



Combo #9

UPGRADE REAR COIL SPRING MOUNT & QA1 SHOCK KIT

Combo includes:

- * (2) QA1 Rear Shocks
- (1) Upper Shock Crossmember
- (2) Eibach Springs
- (*Single Adjustable) (1) Lower Adj. Mount Kit



Combo #10

TRANSMISSION REMOVAL HANDLE KIT

Combo includes:

- (1) Trans Removal Handle - REAR
- (1) Trans Removal Handle - FRONT



Take the
Guess-Work OUT!

#13



BUTTERFLY WHEEL DRAGSTER STEERING KIT

#14



REAR COIL SPRING MOUNT & QA-1 DOUBLE ADJ. SHOCK KIT

#15



CHASSIS STABILIZER & WHEEL CRADLE KIT

#16



ALUMINUM SEAT & MOUNTING KIT

#17



TIRE SCREW TEMPLATE & SCREW KIT

#18

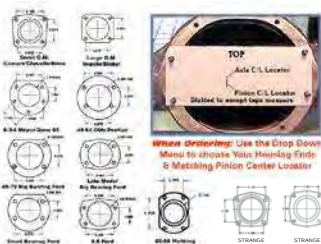

HOUSING ENDS with PINION LOCATOR

#19



LEMONS ROLL CAGE COMBO

#20



DUAL BRAKE CONVERSION KIT

Pipe Master

Layout complicated tube joints in seconds!
 * Simple to use! (Just press, transfer, and trace).
 * Extremely accurate! (Good fit means good welds).
 * Save time! (Eliminate recutting and grinding).
 * Eliminate wasted material!

P/N
 95-030 for 1-5/8" tubing
 95-031 for 1-3/4" tubing



Mock Shock Fixture

These handy shock fixtures are set at 11-1/4" or 13-1/2" and are perfect for replacing & protecting your expensive coil over shocks during the construction process. Sold in pairs and zinc plated for an attractive, long lasting finish.

P/N
 90-020 Mock shocks (13-1/2")
 90-024 Mock shocks (11-1/4")



Specialty Hand Taps

Finding quality hand taps at your corner hardware store is not always the easiest thing to do, especially left hand threaded taps. But a selection of good quality, left & right hand taps are essential for every chassis builder and do-it-yourselfer. S&W's hand taps are made of high grade alloy and built to last.

P/N
 65-T500-L Tap - 1/2"-20 (fine thread) left hand
 65-T500-R Tap - 1/2"-20 (fine thread) right hand
 65-T750-L Tap - 3/4"-16 (fine thread) left hand
 65-T750-R Tap - 3/4"-16 (fine thread) right hand



Double End Wrench Set

Manufactured from heat treated aluminum, for the best compatibility with aluminum fittings. Perfect for tightening A-N hose ends in confined spaces. Wrenches have two different angles on the openings for ease of use. These wrenches come drilled for storage on a rack, thus freeing up space in tool box.

P/N
 65-900100 AN Wrench Set #6-#16



AN Wrench Kit

P/N
 65-900101 AN Wrench Kit



Ladder Bar Jam Nut Wrench

P/N
 90-045 Ladder bar Jam Nut Wrench



4-Link Tube Adjusting Jig

Make sure all your links are the same length before installation! For 1/2", 5/8" or 3/4" rod ends

P/N
 95-027 Tube adjusting jig



Torque Arm Set-Up Jig

40-617-JIG Torque Arm Jig

Tire Screw Template

A must for every serious racer. This handy template makes it quick & easy to locate and mark your tire screw location on your new wheels. Made of .060" aluminum it will last for years! (Tire Screws not included. Add P/N 90-235)

P/N
 90-013 Tire Screw Template w/S&W Logo
 90-013H Tire Screw Template w/Hoosier Logo
 90-235 Tires Screws (35) and drill bit



Tubing Notcher

One of the hardest jobs in any roll cage installation or tube chassis construction has always been getting a good fitting notch on the end of the tubes. And a good notch is the "secret" to a professional appearance on your welds. Now even this job has become easy with the "Ol' Joint Jigger". Designed for home use but strong enough for the serious chassis builder. Hole saws not included.

P/N
 10-RTN100 Ol' Joint Jigger tubing notcher
 10-BASE Optional base (for use with drill press)
 10-1.625 1-5/8" Bi-Metal hole saw
 10-1.750 1-3/4" Bi-Metal hole saw



Drill Not Included

Pinion Center Locators

Measuring your Ford or Dana housing has never been easier! S&W Race Cars pinion center locating plate has been a secret of chassis builders for years. Place the end of your tape measure in the slot and you can measure your housing and pinion offset without guesswork. This tool is a must for the well equipped toolbox.

P/N
 95-019 Ford - 9"
 95-023 Ford - 8"
 95-024 Dana 60
 95-028 GM 12 Bolt
 95-029 Ford 8.8
 95-033 8-3/4" Mopar

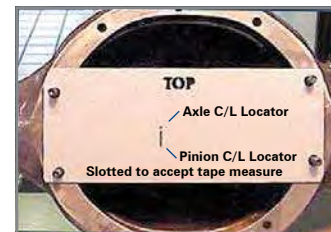

4-Link Instant Center Plotting Kit

This handy tool makes it possible to quickly and easily plot the instant center locations of any S&W Laser Link or Ultra Pro Laser Link at home in your garage or in your trailer at the race track. Made of sturdy .090" thick aluminum this kit includes thumb screws and wing nuts for fast adjustments and also includes bolt on extension arms for combinations where the instant center winds up "way out there". Complete instruction included.

P/N
 95-022 Instant center plotting kit
 95-032 Instant center plotting kit for Pro 500 4 Link

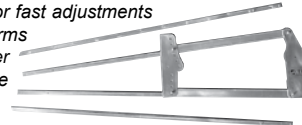

4-Link & Ladder Bar Bracket Spacer Jig

A simple yet effective method for spacing, aligning and holding ladder bar or 4-link front chassis brackets or 4-link housing brackets. Jig maintains the correct spacing during the tacking and welding procedures. Jig spacers have a convenient "grab tab" for easier installation & removal. Also included are two standard grade bolts and nuts. Stop using your expensive rod ends, and grade 8 bolts & nylocks during the welding process! Get a jig spacer kit today!

P/N
 90-022 4-link bracket spacer kit (with 5/8" Bolt)
 90-027 4-link bracket spacer kit for PRO 500 (with 1/2" Bolt)



Spring Pressure Tester

The ultimate tool for checking valve seat pressure on an assembled engine! Built-in 300 lb. reading scale is accurate to within + or - 3% with no need for math conversions Fits roller rockers on Small Block, Big Block and 90° V6 Chevy; Ford 221-302, 351-400 SVO and Ford Windsor engines, and most other wedge-type engines

P/N
 85-62390 Valve seat pressure tester



Cleco Pliers & Sets

A must for every fabricators tool box. These handy, reusable fasteners will hold wheel tubs, aluminum interior panels, body sheet metal or fiberglass securely in place during welding or final assembly. Two sizes are available, 1/8" are recommended for fiberglass, aluminum & lightweight steel and 3/16" for heavier steel panels.

P/N
 95-900 Cleco set - 15 1/8", 15 3/16" and 1 pliers
 95-901 Cleco set - 30 1/8" clecos and 1 pliers
 95-902 Cleco set - 30 3/16" clecos and 1 pliers
 95-9000 Cleco pliers - each
 95-9001 1/8" Cleco - each
 95-9002 3/16" Cleco - each



95-900

Quarter Turn Fastener Tools

P/N
 65-922 Panel dimple tool
 65-933 Quarter-turn button driver

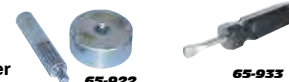

Turbo Tech Gauges

P/N
 95-TG001 Complete Set as shown



PRO 500 WELDED REAR FRAME & SUSPENSION SYSTEM



- P-5 Fully Welded 68" Wheelie Bar Kit is available for these frames, or in kit form with an unwelded "X" member for easy retro fitting to your car! All chrome moly 1-1/4" x .065" wall construction offers light weight with no sacrifice in strength. All S&W Wheelie Bar Kits, including the P-5 Wheelie Bar, feature Ball Bearing Wheels for low drag and consistent launches.

- P-5 Fully Welded Rear Frame available in 22", 24", 26" and 28" widths in your choice of Mild Steel or Chrome Moly



- S&W's P-5 Chrome Moly Welded Swing Arm Kit is 'Dragster Technology' for Your Door Car!



- 1-1/4" x .095 wall Chrome Moly Welded Wishbone Kit uses 3/4" Rod Ends and is strong enough for even heavyweight doorslammer applications.



- Each P-5 Fully Welded Rear Frame comes with an Anti-Roll Bar Mount fully installed.

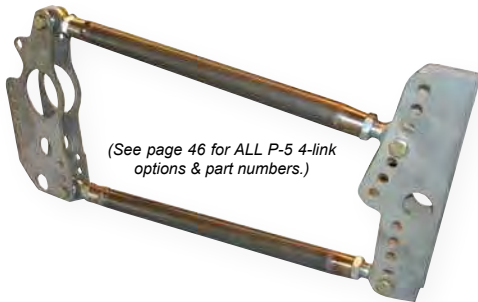

(See page 46 for ALL P-5 4-link options & part numbers.)

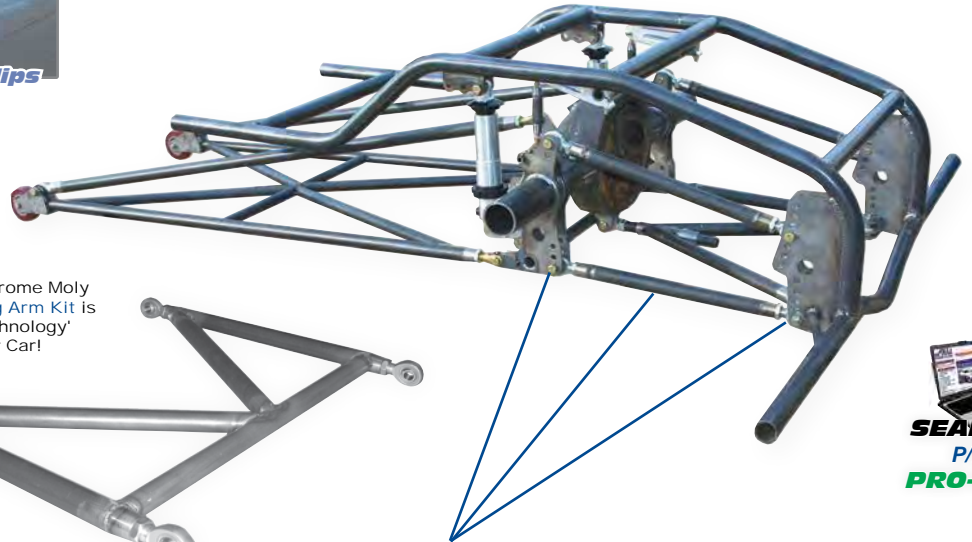

- The P-5 4-link Package includes brackets that feature 1/2" holes for more adjustments! (An optional bracket doubler kit available too) Chrome Moly 1-1/4" x .095" Top & 1-3/8" x .095" Bottom Bars. Weld-In Tube Adapters with wrench flats for easy adjustability. Premium Moly FK Rod Ends utilize 3/4" threads & 1/2" holes for the highest strength rod end combo possible

Round-Tube-Ladder Bar Frames

Available as 28" or 32" Length in Mild Steel or Chrome Moly



- 10-350 22" wide Frame with 28" long Ladder Bars
- 10-351 24" wide Frame with 28" long Ladder Bars
- 10-352 26" wide Frame with 28" long Ladder Bars
- 10-353 28" wide Frame with 28" long Ladder Bars
- 10-333 22" wide Frame with 32" long Ladder Bars
- 10-330 24" wide Frame with 32" long Ladder Bars
- 10-331 26" wide Frame with 32" long Ladder Bars
- 10-332 28" wide Frame with 32" long Ladder Bars

COMPLETE PRO 500 Package:

- PRO 500 Mild Steel 4-Link Frame - 22", 24", 26" or 28"
- PRO 500 Chrome Moly 4-Link Frame - 22", 24", 26" or 28"

Installation of this frame requires the installation of at least an 8 point roll bar for proper support

All components are available individually or Complete Package

- PRO 500 Anti Roll Bar Package
- PRO 500 Welded Wishbone Kit (Unwelded Avail)
- PRO 500 Welded Swing Arm Kit - 22", 24", 26" or 28" (Custom Avail)
- PRO 500 Unwelded Wheelie Bar Kit (Welded Avail)
- PRO 500 4-Link Package with 8 CM Rod Ends & CM Brackets

Note - The 4-link Package is available separately in mild steel or chrome moly and with or without rod ends.

Mild steel 4-link kits use 1"x.156" wall tubes on the top & bottom links, while chrome moly kits use 1-3/8"x .095" wall bottom tubes and 1-1/4"x.095" wall top tubes. S&W Race Cars insists that only 4130 moly rod ends be used in any 4-link application.

See Page 46 for ALL PRO 500 4-link options & part numbers.



ALL S&W
PRO 500
Complete
Package &
Parts are
\$ ITEMS



PRO-SERIES WELDED REAR FRAME & SUSPENSION PACKAGE

S & W Race Cars rear frame packages are designed to greatly reducing the time and effort previously required to back-half your car. Each frame arrives completely jig-welded, with the 4-link or ladder bar mounts and upper shock crossmember fully installed. PRO SERIES rear frames are available in 24", 26", & 28" frame rail widths, assuring you of a fit that is right for your car. Also available are custom narrowed, completely welded, 9" Ford rear axle housings. Every rear axle housing is made from a NEW Ford stamping and is fully welded with the 4-link or ladder bar brackets and lower shock mounts installed as well as a fill cap and drain plug. Rear axle housings are jig-welded to assure straightness and are assembled with late model big Ford housing ends.

Note: ALL Packages Include Chrome Moly Rod Ends

Installation of these frames require the installation of at least an 8 point roll bar for proper support



Standard Package Includes:

- Welded Rear Frame • 32" S & W **Double Adjustable Ladder Bars** or 4-Link tubes & housing brackets • Panhard Bar or Track Locator • Shock and Spring kit with adj. lower shock mounts • PVC coated springs matched to your application • All suspension mounting hardware • Complete instructions • **Chrome Moly Rod Ends**

SEARCH
P/N
10-300

Standard Ladder Bar Package - 24", 26" or 28"

With Drag Race Shock Upgrade

- Strange alum. ext. adj. coil-overs
- QA1, alum. ext. adj. coil-overs

SEARCH
P/N
10-400

Standard 4-Link Package - 24", 26" or 28"

With Drag Race Shock Upgrade

- Strange alum. ext. adj. coil-overs
- QA1, alum. ext. adj. coil-overs

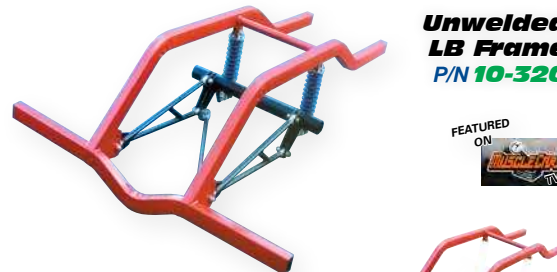

**Unwelded
LB Frame**
P/N **10-320**



FRAME ONLY
LADDER BAR P/N 10-300
4-LINK P/N 10-400

Package Options for PRO/SERIES Package

(Add to Package Price*)

- Ladder bar 9" Ford axle housing
- Above with Back Brace



- 4-link 9" Ford axle housing
- 4-link 9" Ford axle housing with 2x3 back brace
- Anti-Roll Bar



**Unwelded
4-Link
Frame**
P/N **10-420**



FRAME WIDTH CALCULATOR

The chart to the right is designed to aid you in determining which width frame is right for your application.

S&W's FRAME WIDTH CALCULATOR

is Available On-Line. Print it out and then call your Sales Representative for additional assistance.

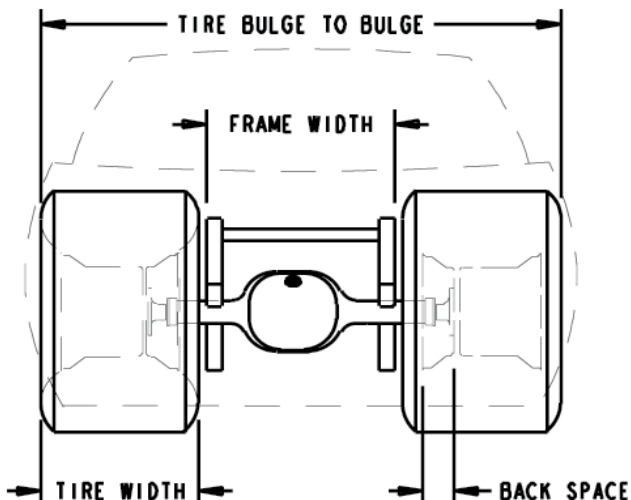

Frame Width	Tire Manufacture	Tire Size	Tire Width	Back Space	Overall width
24"	M-T	29x18.5	17.6"	4"	62.1"
24"	M-T	31X18.5R-15LT	17.5"	4"	62"
24"	M-T	33X21.5-15LT	19.6"	4"	64.1"
24"	HOOSIER	31X18.5R-15LT	18.0"	4"	62.5"
24"	HOOSIER	33X21.5R-15LT	21.3"	4"	65.8"
24"	GOODYEAR	32X14-15	17.0"	4"	61.5"
24"	GOODYEAR	32X16-15	18.4"	4"	62.9"
24"	GOODYEAR	33X15-15	17.5"	4"	62"
24"	GOODYEAR	33X17-15	20.6"	4"	65.1"
26"	M-T	29x18.5	17.6"	4"	64.1"
26"	M-T	31X18.5R-15LT	17.5"	4"	64"
26"	M-T	33X21.5-15LT	19.6"	4"	66.1"
26"	HOOSIER	31X18.5R-15LT	18.0"	4"	64.5"
26"	HOOSIER	33X21.5R-15LT	21.3"	4"	67.8"
26"	GOODYEAR	32X14-15	17.0"	4"	63.5"
26"	GOODYEAR	32X16-15	18.4"	4"	64.9"
26"	GOODYEAR	33X15-15	17.5"	4"	64"
26"	GOODYEAR	33X17-15	20.6"	4"	67.1"
28"	M-T	29x18.5	17.6"	4"	66.1"
28"	M-T	31X18.5R-15LT	17.5"	4"	66"
28"	M-T	33X21.5-15LT	19.6"	4"	68.1"
28"	HOOSIER	31X18.5R-15LT	18.0"	4"	66.5"
28"	HOOSIER	33X21.5R-15LT	21.3"	4"	69.8"
28"	GOODYEAR	32X14-15	17.0"	4"	65.5"
28"	GOODYEAR	32X16-15	18.4"	4"	66.9"
28"	GOODYEAR	33X15-15	17.5"	4"	66"
28"	GOODYEAR	33X17-15	20.6"	4"	69.1"



social @SWRACECARS

website SWRACECARS.COM

DIRECT-FIT WELDED REAR FRAME & SUSPENSION PACKAGES

68-74 Nova Ladder Bar & 4-Link

This package also fits: 68-72 Buick Apollo, 68-72 Olds Omega and 68-92 Pontiac Ventura
S&W Race Cars 68-72 Nova frame package is great for Pro/Street or drag racing. Designed to greatly reduce the time and effort previously required to back-half your car. Each frame is completely jig-welded, with the ladder bar or 4-link mounts and upper shock crossmember fully installed. These rear frames are available in 24", 26", and 28" frame rail widths. Rear axle housings are available for these frames.

ALL Packages Include Chrome Moly Rod Ends

Installation of these frames require the installation of at least an 8 point roll bar for proper support



Jim Ransom



All S&W
Frame
Kits are
\$ ITEMS

FRAME ONLY

LADDER BAR
4-LINK

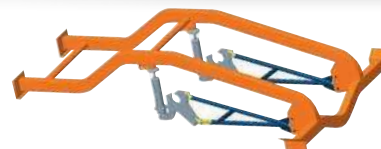

SEARCH
P/N
10-512

Standard Ladder Bar Package

With Drag Race Shock Upgrade

- Strange alum. ext. adj. coil-overs
- QA1, alum. ext. adj. coil-overs



SEARCH
P/N
10-515

Standard 4-Link Package

With Drag Race Shock Upgrade

- Strange alum. ext. adj. coil-overs
- QA1, alum. ext. adj. coil-overs

Standard Package Includes:

- Welded Rear Frame • 32" S & W Double Adjustable Ladder Bars or 4-Link tubes & housing brackets • Panhard Bar or Track Locator • Shock and Spring kit with adj. lower shock mounts • PVC coated springs matched to your application • All suspension mounting hardware • Complete instructions • Chrome Moly Rod Ends

Package Options for 68-74 Nova (Add to Package Price*)



- Ladder bar 9" Ford axle housing



- 4-link 9" Ford axle housing
- 4-link 9" Ford axle housing with 2x3 back brace
- Anti-Roll Bar

67-69 Camaro 4-Link

S&W Race Cars 67-69 Camaro Frame is great for Pro/Street or drag racing. Designed to reduce the time and effort previously required to back-half your car. Each frame arrives completely jig-welded, with the 4-link mounts and upper shock crossmember fully installed. These rear frames are available in 24", 26", and 28" frame rail widths. Rear axle housings are available for these frames.

ALL Packages Include Chrome Moly Rod Ends

Installation of these frames require the installation of at least an 8 point roll bar for proper support

Standard Package Includes:

- 24", 26" or 28" welded rear frame • 4-link tubes & housing brackets • Driveshaft loop • Fully welded track locator • Shock and spring kit • Adjustable lower shock mounts • PVC coated springs matched to your application • All suspension hardware • Complete instructions • Chrome Moly Rod Ends

Package Options for 67-69 Camaro

- Panhard Bar - (Add to Package Price*)
Exchange for Track Locator (Panhard should be used on all street applications)
- 4-link 9" Ford axle housing
- 4-link 9" Ford axle housing with 2x3 back brace

FRAME ONLY Available
4-LINK



Tony Valerio



SEARCH
P/N
10-510

Standard 4-Link Package

With Drag Race Shock Upgrade

- Strange alum. ext. adj. coil-overs
- QA1, alum. ext. adj. coil-overs

55-56-57 Chevy Ladder Bar Package

These S & W frames are designed to fit up to 15x33 drag tires, or 31x18.5 street radial tires. The frame comes completely welded with 2x3 frame rails, ladder bar crossmember with ladder bar front mounts, rear shock crossmember with upper shock mounts, panhard bar mount and is completely jig-welded at S & W to assure you of proper clearances and ease of installation. The complete welded rear frame is designed to fit under your stock floor with minor modifications and retains most stock body and bumper mounts. This S & W frame must be used with, at least an 8 point roll bar to properly support your new welded frame unit.

Includes Chrome Moly Rod Ends

Installation of these frames require the installation of at least an 8 point roll bar for proper support

Standard Package Includes:

- Welded rear frame • 32" S & W Double Adjustable Ladder Bars
- Fully welded Panhard Bar • Pro/Street shock and spring kit with adj. lower shock mounts
- PVC coated springs matched to your application
- All suspension mounting hardware • Complete instructions • Chrome Moly Rod Ends

Package Options for 55-56-57 Chevy

(Add to Package Price*)



- Ladder bar 9" Ford axle housing

FRAME ONLY Available
LADDER BAR

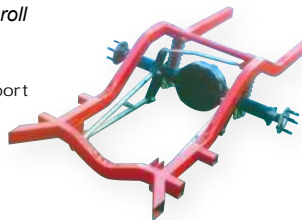

Dwight Overlock

Photo shows optional 9" Ford housing with axles



SEARCH
P/N
10-500

Standard Ladder Bar Package

With Drag Race Shock Upgrade

- Strange alum. ext. adj. coil-overs
- QA1, alum. ext. adj. coil-overs

DIRECT-FIT WELDED REAR FRAME & SUSPENSION PACKAGES

64-72 Chevelle Ladder Bar Package

This package also fits: 70-72 Monte Carlo, 64-72 El Camino, 64-72 Cutlass/442, 64-72 Tempest/GTO, 64-72 Skylark and Gran Sport with some modifications, please contact the S&W tech department. This S & W frames is designed to fit up to 15x33 drag tires, or 31x18.5 Hoosier street radial tires. The frame comes completely welded with 2x3 frame rails, ladder bar crossmember with ladder bar front mounts, rear shock crossmember with upper shock mounts, and panhard bar mount. Frame is completely jig-welded for ease of installation. The complete welded rear frame is designed to fit under your stock floor with minor modifications and retains most stock body and bumper mounts. This frame must be used with at least an 8 point roll bar.

ALL Packages Include Chrome Moly Rod Ends

Installation of these frames require the installation of at least an 8 point roll bar.

Standard Package Includes:

- Welded rear frame • 32" S & W Double Adjustable Ladder Bars
- Fully welded panhard bar • Pro/Series shock and spring kit with adj. lower shock mounts
- PVC coated springs matched to your application
- All suspension mounting hardware • Complete instructions • Chrome Moly Rod Ends

Standard Ladder Bar Package

With Drag Race Shock Upgrade

- Strange alum. ext. adj. coil-overs
- QA1, alum. ext. adj. coil-overs

SEARCH
P/N
10-501



All S&W
Frame
Kits are
\$ ITEMS



Mike Shupp



FRAME ONLY Available
LADDER BAR

Package Options for 64-72 Chevelle (Add to Package Price*)



- Ladder bar 9" Ford axle housing

78-83 Malibu Ladder Bar & 4-Link

This package also fits: 78-88 Monte Carlo, 78-87 Regal, 78-87 Grand National, 78-87 Cutlass, 78-87 Grand Prix, ElCamino (ask)

The S&W welded frame for the 78-88 GM "G" body is designed to fit up to 15 x 33 drag tires or 31x18.5 Hoosier street radial tires. This frame has 2" x 3" mandrel formed frame rails, front crossmember, ladder bar or 4-link front mounts, rear shock crossmember, upper shock mounts and a panhard bar mount. Frame is completely jig-welded for ease of installation. This frame is designed to fit with a minimal amount of cutting to the stock floor and original frame, and designed to retain the stock body and bumper mounts. This frame must be used with at least a 8 point roll bar. The standard package includes our S&W Pro/ Series non-adjustable shock & spring kit. Our adjustable lower shock mounts have 5-1/2" of ride height adjustment. Strange Engineering or QA-1 coil over shocks are also available for the racer desiring the maximum in adjustability.

ALL Packages Include Chrome Moly Rod Ends

Installation of these frames require the installation of at least an 8 point roll bar for proper support.

Standard Package Includes:

- Welded rear frame • 32" S & W Double Adjustable Ladder Bars or 4-Link tubes & housing brackets
- Panhard bar or Track locator • Shock and spring kit with adj. lower shock mounts
- PVC coated springs matched to your application • All suspension mounting hardware
- Complete instructions • Chrome Moly Rod Ends

Standard Ladder Bar Package -

With Drag Race Shock Upgrade

- Strange alum. ext. adj. coil-overs
- QA1, alum. ext. adj. coil-overs

SEARCH
P/N
10-505

Standard 4-Link Package -

With Drag Race Shock Upgrade

- Strange alum. ext. adj. coil-overs
- QA1, alum. ext. adj. coil-overs

SEARCH
P/N
10-508



All S&W
Frame
Kits are
\$ ITEMS



Mike DeLuca



FRAME ONLY Available
LADDER BAR
4-LINK



Package Options for 78-83 Malibu (Add to Package Price*)

- Ladder bar 9" Ford axle housing
- 4-link 9" Ford axle housing
- 4-link 9" Ford axle housing with 2x3 back brace
- Anti-Roll Bar



Complete rear housings also available



DIRECT-FIT WELDED REAR FRAME & SUSPENSION PACKAGES

82-02 Camaro/Firebird Ladder Bar & 4-Link

The S&W ladder bar frame for the 82-02 Camaro & Firebird features 24" wide frame rails and is designed to fit up to 15 x 33 drag tires or 31x18.5 Hoosier street radial tires. The 4-link frame is available 24", 26" or 28" wide, making it perfect for anything from 10.5 racing to Pro/Street. Each frame comes completely welded with 2" x 3" mandrel formed frame rails, front crossmember, ladder bar or 4-link front mounts, rear shock crossmember with upper shock mounts and a panhard bar mount. The frame is completely jig-welded for ease of installation, and is designed to fit with a minimal amount of cutting to the stock floor. This frame must be used with at least an 8 point roll bar for support.

ALL Packages Include Chrome Moly Rod Ends



Kaitlyn-Krause

Installation of these frames require the installation of at least an 8 point roll bar for proper support

See Page 38 & 39 for Bolt-On Components for 1982 to 2002 Camaros and Firebirds

FRAME ONLY

LADDER BAR 4-LINK



Picture shows optional 9" Ford rear housing



Standard Ladder Bar Package

- With Drag Race Shock Upgrade**
- Strange alum. ext. adj. coil-overs
 - QA1, alum. ext. adj. coil-overs

Picture shows 4-link Pkg.

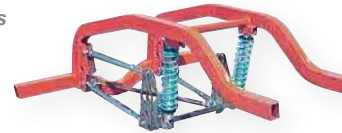

Standard Package Includes:

- Welded Rear Frame • 32" S & W Double Adjustable Ladder Bars or 4-Link tubes & housing brackets
- Panhard Bar or Track Locator • Shock and Spring Kit with adj. lower shock mounts
- PVC coated springs matched to your application • All suspension mounting hardware
- Frame Connectors • Complete Instructions • Chrome Moly Rod Ends

Standard 4-Link Package

- With Drag Race Shock Upgrade**
- Strange alum. ext. adj. coil-overs
 - QA1, alum. ext. adj. coil-overs

Package Options for 82-02 Camaro/Firebird & 79-04 Mustang (below)

(Add to Package Price*)



- Ladder bar 9" Ford axle housing



- 4-link 9" Ford axle housing
- 4-link 9" Ford axle housing with 2x3 back brace
- Anti-Roll Bar

79-04 Mustang Ladder Bar & 4-Link

Specifically designed for Ford's most popular "pony car" this S & W frame is designed to fit up to 15x33 drag tires or 31x18.5 Hoosier street radial tires. This frame comes completely welded with 2x3 frame rails, front crossmember, ladder bar or 4-link front mounts, rear shock crossmember with upper shock mounts, and a panhard bar mount. This frame requires rear floor pan removal and must be used with at least an 8 point roll bar to support it. Standard packages include our S&W Pro/Street shock & spring kit which is designed for racers on a limited budget. This kit features standard non-adjustable shocks, coil springs and lower mounts with 5-1/2" of ride height adjustment and all mounting hardware.

FRAME ONLY

LADDER BAR 4-LINK

Installation of these frames require the installation of at least an 8 point roll bar for proper support

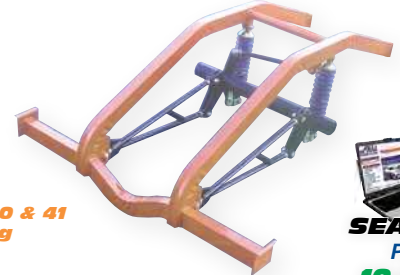

See Page 40 & 41 for Mustang Bolt-Ons



Standard Ladder Bar Package

- With Drag Race Shock Upgrade**
- Strange alum. ext. adj. coil-overs
 - QA1, alum. ext. adj. coil-overs



Standard 4-Link Package

- With Drag Race Shock Upgrade**
- Strange alum. ext. adj. coil-overs
 - QA1, alum. ext. adj. coil-overs
 - Anti-Roll Bar



Lee Grinnell



Standard Package Includes:

- Welded Rear Frame • 32" S & W Double Adjustable Ladder Bars or 4-Link tubes & housing brackets
- Panhard Bar or Track Locator • Shock and Spring Kit with adj. lower shock mounts
- PVC coated springs matched to your application • All suspension mounting hardware
- Frame Connectors • Complete Instructions • Chrome Moly Rod Ends



S&W Only Uses BRAND NEW 9" Ford Ladder Bar & 4-Link Housings for all Frame Packages!



DIRECT-FIT WELDED TRUCK FRAMES & SUSPENSION PACKAGES

82-04 Chevrolet S-10 Pick-Up Ladder Bar & 4-Link

The S&W S-10 Chevy Package fits standard or ext. cab, long or short bed trucks. Does not fit Blazer!

S&W Race Cars fully-welded Chevy S-10 rear frame kit is designed specifically for the do-it-yourselfer. Each frame is constructed of .120" wall rectangular steel tubing and jig-welded to assure straightness and proper alignment of suspension mounting points. Designed to fit under the bed and retain all stock bed mounting locations. Frames come with front ladder bar or 4-link mounts, upper shock crossmember and panhard bar mount fully installed. Also included is an inner wheel tub widening kit. Installation of this frame package will allow use of 31x18.5 Hoosier street radial tires.

ALL Packages Include Chrome Moly Rod Ends
Roll Bar Installation Not Required!

****See More S10**
on Page 43**



Standard Package Includes:

- Welded Rear Frame • 32" S & W Double Adjustable Ladder Bars or 4-Link tubes & housing brackets
- Panhard Bar • QA1, alum. ext. single adj. coil-overs and Spring Kit with adj. lower shock mounts
- PVC coated springs matched to your application
- All suspension mounting hardware • Complete Instructions
- Chrome Moly Rod Ends

Standard Ladder Bar Package

- With Drag Race Shock Option:**
- QA1 alum. ext. adj. coil-overs

Double Adjustable QA-1 & STRANGE are Avail. for Additional Charge

Standard 4-Link Package

- With Drag Race Shock Option:**
- QA1 alum. ext. adj. coil-overs

Double Adjustable QA-1 & STRANGE are Avail. for Additional Charge



SEARCH P/N 10-503

SEARCH P/N 10-509

Package Options for 82-04 S-10 Pick Up

(Add to Package Price*)

- Ladder Bar 9" Ford axle housing
- Complete Steel Wheel Tub Replacement P/N 95-377
- Anti-Roll Bar
- 4-link 9" Ford axle housing
- 4-link 9" Ford axle housing with 2x3 back brace includes frame upgrade

FORD Ranger OWNERS See Pg.47!

88-97 Chevrolet C-1500 Pick-Up Ladder Bar

S&W Race Cars fully-welded short bed Chevy C-1500 Pickup rear frame kit is designed specifically for the do-it-yourselfer. Each frame is constructed of .120" wall rectangular steel tubing and completely jig-welded to assure straightness and proper alignment of suspension mounting points. Frame is designed to fit under the bed and retain the stock bed mounts. These frame comes with front ladder bar mounts, upper shock crossmember and panhard bar mount installed. Also included are inner wheel tub extensions. Installation of this frame package will allow use of 31x18.5 Hoosier street radial tires or 15" x 33" Goodyear drag tires. Frames are available separately or complete with the ladder bar/shock and spring suspension package. The standard package includes QA1 aluminum single adjustable coil-over spring and shock kit with adjustable lower shock mounts. Adjustable lower mounts have 7-1/2" of ride height adjustment. Also available is a narrowed 9" Ford rear axle housing. Housing is completely fixture-welded with all ladder bar, shock mount and panhard bar brackets, late model Ford housing ends, filler cap and drain plug.

ALL Packages Include Chrome Moly Rod Ends
Roll Bar Installation Not Required!

Standard Package Includes:

- Welded Rear Frame • 32" S & W Double Adjustable Ladder Bars
- Panhard Bar • QA1, alum. ext. single adj. coil-overs and Spring Kit with adj. lower shock mounts
- PVC coated springs • Wheel tub widening Kit
- Frame reinforcing kit for original frame
- All suspension mounting hardware
- Complete instructions • Chrome Moly Rod Ends

Standard Ladder Bar Package

- With Drag Race Shock Upgrade**
- QA1 alum. ext. adj. coil-overs

Double Adjustable QA-1 & STRANGE are Avail. for Additional Charge



Jeff Nye

FRAME ONLY Available

NEW LOWER package price

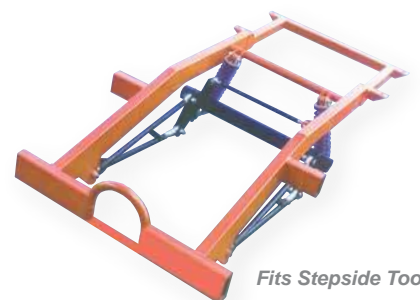

SEARCH P/N 10-506

Package Options for 88-97 C-1500

(Add to Package Price*)

- Track Locator Bar- Exchange for Panhard Bar (Track Locator Bar should be used on all racing applications)
- Ladder Bar 9" Ford axle housing



UNWELDED REAR FRAME & SUSPENSION PACKAGES

Unwelded Ladder Bar Rear Frame Package

This S&W rear frame package is designed specifically for the true "do-it-yourselfer". Shipped unassembled, these kits are perfect for the budget-minded individual who desires professional chassis shop quality from his own garage. These frame packages are available for many popular GM, Ford, Mopar and AMC body styles. Frame packages come complete with mandrel formed frame rails and connectors and are designed to fit under the stock floor pan with a minimal amount of cutting.

***NOTE: Modifications to stock floor is required. An S&W roll bar or roll cage is required for proper installation.**

Standard Package Includes: Package Includes Chrome Moly Rod Ends

- Mandrel formed rear frame rails • Frame connectors • 32" or 36" S & W Double Adjustable Ladder Bars
- Ladder bar front crossmember • Track locator or panhard bar • Pro/Series shock kit
- PVC coated coil-over springs matched to your application • Upper shock crossmember
- Adjustable lower shock mounts • All suspension mount hardware • Chrome Moly Rod Ends

Package Options for Unwelded Ladder Bar (Add to Package Price)

- Aluminum Wheel Tubs
- Steel Wheel Tubs

***NOTE:** The frame rails and connectors featured in this package are available separately.

P/N 10-320 Unwelded 2x3 Ladder Bar Package With Drag Race Shock Upgrade (Some models slightly higher)

- Strange alum. ext. adj. coil-overs • QA1, alum. ext. adj. coil-overs



Unwelded 4-Link Rear Frame Package

Designed specifically for the "do-it-yourselfer". Shipped unassembled, this package is perfect for the budget-minded individual who desires professional chassis shop quality from his own garage. Package is sold less 4-link rod ends.

***NOTE: Modifications to stock floor is required. An S&W roll bar or roll cage is required for proper installation.**

Standard Package Includes: Package Includes Chrome Moly Rod Ends

- Mandrel formed rear frame rails • 8' frame connector tubing • Laser link 4-link less rod ends
- 2" x 3" crossmember • Track locator or panhard bar • Shocks with spring mounts
- PVC coated coil-over springs matched to your application • Upper shock crossmember
- Adjustable lower shock mounts • 38" or 40" steel wheel tubs
- All suspension mounting hardware • Chrome Moly Rod Ends

Package Options for Unwelded 4-Link (Add to Package Price)

- Aluminum Wheel Tubs
- Anti-Roll Bar

P/N 10-421 & 10-422 Unwelded ROUND TUBE 4-Link Package
Call for More Info

P/N 10-420 Unwelded 2x3 4-Link Package With Drag Race Shock Upgrade

- Strange alum. ext. adj. coil-overs
- QA1, alum. ext. adj. coil-overs

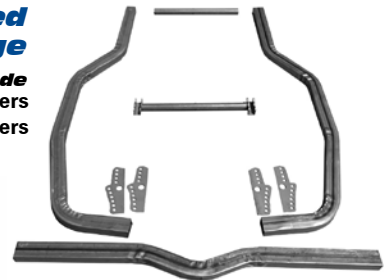

NOTE: S&W Race Cars makes no claims regarding legality of these products for street use. It is the responsibility of the purchaser to check his or her local regulations before ordering.

CROSSMEMBERS & DRIVESHAFT LOOPS

Driveshaft Loop & Tunnel Kits

Chrome Moly Tunnel & Drive Shaft Loops, Includes; (2) Drive Shaft Loops & 2-Pc Tunnel, Crossmembers, Quick Pins & Hardware, Tunnel is 5-1/2" WD X 24" Long or 36" Long

- P/N 14-117 24" Chrome Moly DS Loop/Tunnel for 7.49 or Quicker
- P/N 14-117MS 24" Mild Steel DS Loop/Tunnel. Bolt-In Std. Quick Pins Optional
- P/N 14-122 36" Chrome Moly DS Loop/Tunnel for 7.49 or Quicker
- P/N 14-122MS 36" Mild Steel DS Loop/Tunnel. Bolt-In Std. Quick Pins Optional



Driveshaft Loops

S&W offers two different styles of driveshaft loops, one of which is sure to suit the needs of any chassis builder. A round tube crossmember with removable loop is available for custom applications. This loop features a 36" crossmember and comes complete with grade 8 hardware. A bolt-in, adjustable loop is available for cars with stock floors.

- P/N 14-116 Weld-on driveshaft loop & crossmember
- P/N 14-116-1 Weld-on driveshaft loop only
- P/N 14-116CM Weld-on driveshaft loop & crossmember (Chrome Moly)
- P/N 14-118 S-10 driveshaft loop & crossmember
- P/N 14-361 Bolt-in driveshaft loop
- P/N 14-365 Bolt-in driveshaft loop 79-93 Mustang
- P/N 95-360 Chrome Moly Loop only 4" ID
- P/N 95-362 Chrome Moly Loop only 5-1/2" ID

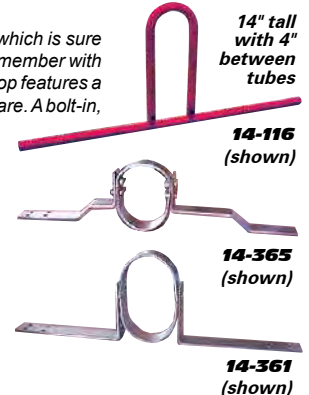

Transmission Crossmembers

S&W transmission crossmembers are designed for easy removal of the transmission. Strong, but lightweight, they fit applications up to 36" wide. Universal design allows the crossmember to fit round or rectangular frame rails.

- P/N 14-110 Universal
- P/N 14-111 55-56-57 Chevy (welded)



Offset Transmission Crossmember Kits

S&W's new trans crossmember is designed for 2x3 or round tube cars where the lower frame rail is typically lower than the transmission tailshaft. Kit can also be used on any car requiring an elevated trans mount. Sfi Certified.

- P/N 40-248 Offset trans mount & crossmember kit - round tube, chrome moly (Sfi 25.1, 25.2, 25.3, 25.4, 25.5)
- P/N 40-249 Offset trans mount & crossmember kit
- P/N 40-250 Offset trans mount & crossmember kit 2x3 rectangular tube, mild steel
- P/N 40-246CM Chrome Moly removable crossmember kit for Round Frame Rail
- P/N 40-246MS Mild Steel removable crossmember kit for Round Frame Rail
- P/N 40-246RC Mild Steel removable crossmember kit for Rectangular Frame Rail



2" X 3" & Round Tube Crossmembers

Great for the do-it-yourselfer, these crossmembers are useful for many applications. Available with a 2", 3" or 4" drop.

- Length: RT 54-5/8" Wide | 2X3 Tube 63" Wide
- P/N 40-209 3" drop KIT (2"X3"X.120" wall)
- P/N 40-209-3 3" drop (2"X3"X.120" wall)
- P/N 40-209-4 4" drop (2"X3"X.120" wall)
- P/N 40-213-2 2" drop (2"X3"X.083" wall)
- P/N 40-213-3 3" drop (2"X3"X.083" wall)
- P/N 40-213-4 4" drop (2"X3"X.083" wall)
- P/N 40-210 3" drop KIT (Round Tube 1-3/4" Dia.X.134" wall)
- P/N 40-210-2 2" drop (Round Tube 1-3/4" Dia.X.134" wall)
- P/N 40-210-3 3" drop (Round Tube 1-3/4" Dia.X.134" wall)
- P/N 40-210-4 4" drop (Round Tube 1-3/4" Dia.X.134" wall)



FRAME RAILS & COMPONENTS

S&W frame rails are designed for the do-it-yourselfer wishing to narrow his or her rear frame section to accommodate modern drag race or pro/street tires. Made from 2"x3"x.083" wall mild steel rectangular tubing, and mandrel formed on our own computer controlled machinery, they are substantially lighter than stock rear frames. These frame rails offer the do-it-yourselfer the added savings of less expensive U.P.S. shipping charges. All S&W frame rails are sold in pairs.

OEM Upgrade Rear Frame Rails

S&W rear frame rails are designed for applications where retaining the rear floor pan is either more practical or more desirable. These rails are designed to follow the original rear floor contour and install with minimal cutting or modifications. These rails are available to either retain the original rear leaf springs (if so equipped) or in coil-over versions for the builder wishing to update his rear suspension with the addition of coil over shocks or an S&W Pro/Series 2000 shock & spring kit. Sold in pairs. S&W frame connectors are designed to be used in conjunction with our rear frame rails. They provide additional stiffness to your stock bodied car by tying the front subframe to the rear frame rail. O.E.M Upgrade Part.



Al Morgan

'63-'81 Corvette Unwelded 4-Link Pkg's

- P/N 10-011 Unwelded Frame Rails, Crossmember & Loop
- P/N 40-122 4-Link Kit without Rod Ends
- P/N 40-121 Lazer Link Rod End Package



All S&W Frame Rails & Connectors are \$ ITEMS

TEST FIT FIRST!
ASK US About Frame Rail TEMPLATES

P/N 10-120 Frame Rail Template

Frame Connector End Type Chart:

F-Rail P/N	F-Connector P/N	Description
10-001	10-601	67-69 Camaro, Firebird • leaf spring
10-003	10-601	67-69 Camaro, Firebird • coil-over
10-004	10-604	70-81 Camaro, Firebird • leaf spring
10-104	10-604	70-81 Camaro, Firebird • coil-over
10-005	included	82-92 Camaro, Firebird • coil-over
10-028	included	82-92 Camaro • 4-link SS/GT
10-006	included	64-72 Chevelle, GTO, 442 • coil-over
10-007	40-213-3	55-57 Chevy • coil-over
10-008	10-608	62-67 Chevy II • leaf spring
10-009	10-608	62-67 Chevy II • coil-over
10-010	10-610	68-78 Nova, Ventura • coil-over
10-012	10-610	68-78 Nova, Ventura • leaf spring
10-011	included	63-81 Corvette • 4-link, coil-over
10-013	10-613	Vega, Monza • coil-over
requires special ladder bar crossmember 40-210V sold on page 29		
10-014	included	78-88 GM Intermediate • coil-over
10-031	10-631	Mopar A Body • coil-over (except 67-69 Barracuda)
10-032	10-632	(C) Mopar A Body • leaf spring (except 67-69 Barracuda)
10-033	10-633	(C) Mopar E Body • leaf spring
10-035	10-633	(C) Mopar E Body • coil-over
10-036	10-636	(C) Mopar B Body • coil-over
10-038	-	2 X 3 Frame Rail, Ladder Bar Low Profile
10-039	10-639	(B) Arrow • coil-over
10-040	10-631	(C) 67-69 Barracuda • coil-over
10-041	10-632	(C) 67-69 Barracuda • leaf spring
10-042	-	Sport Compact, Ladder Bar, Round Tube
10-050	-	Pro Touring Chassis Frame Rail
10-089	10-689	(B) 94 Mustang GT • coil-over
10-090	N/A	- 48-53 Anglia • coil-over
10-091	included	- 1940 Ford • coil-over
10-092	10-692	(B) 64-73 Mustang, 70-77 Maverick • coil-over
10-093	10-693	(B) 64-73 Mustang, 70-77 Maverick • leaf spring
10-094	10-694	(B) 61-65 Falcon • coil-over
10-095	10-695	(B) Pinto, 74-93 Mustang • leaf spring
10-096	10-696	(B) Pinto, 74-93 Mustang • coil-over
10-097	10-697	(C) 68-70 AMX • coil-over
10-099	10-699	(C) 66-67 Fairlane • coil-over
10-100	10-699	(C) 66-67 Fairlane • leaf spring
10-113	-	- for 10-502 Camaro Frame Kit
10-114	-	- for Mustang Kit Rail
10-116	N/A	- for Malibu Welded Frame Kit
10-410-01	-	- for Round Tube Frame Kits
07-100	-	- for Street Roadster Kit

All Rails Available as 2x3 or Round Tube

Universal Rear Frame Rails

S&W universal 2" x 3" rear frame rails are designed for applications where removing the rear floor pan is either more practical or more desirable. These rails allow the builder to place the rail higher in the body resulting in a lower finished ride height. Sold in pairs

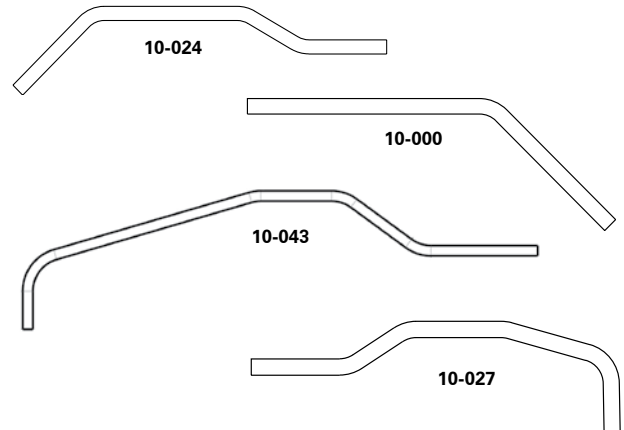

Rail P/N	Description
10-000	Universal. 45 degree
10-024	Universal, ladder bar rail used in frame # 10-300
10-027	Universal 4-link rail as used in frame # 10-400
10-043	Universal, Round Tube ladder bar rail used in frame # 10-513 <i>Per Pair</i>

Custom Frame Rails

S&W Race Cars can build you a custom pair of rails to your spec. Some restrictions do apply. Please call the S&W Sales Department for more info.

- P/N 10-030 Custom 2" x 3" x .083" frame rails
- P/N 10-037 Custom 1-5/8" x .134" mild steel frame rails

Universal Frame Connectors

- P/N 10-600-3 Universal, 3ft Long, Pair
- P/N 10-600-4 Universal, 4ft. Long, Pair



Firewall Kit

S&W's universal firewall kit is perfect for replacing your heavy stock firewall or for building a firewall for tube chassis cars. Kit includes 24" x 48" steel or aluminum center panel with flanged opening to match tunnel kit, 1- 12" x 64" steel top panel, 2- 11-1/2" x 24" steel side panels. Some trimming required.

- P/N
95-111 Firewall kit with aluminum center
95-115 Firewall kit with steel center

Aluminum Door Panel Kit

Kit includes (2) 48" x 26" panels with bent 2" lip along top. Some trimming required. **PVC Protective Coating Incl.**

- P/N
95-113 Aluminum door panel kit

Aluminum Door Pull Kit with or without Strap Kit

• 109 kits included (2) aluminum door pulls and hardware • 120 kits included (2) aluminum door pulls (2) door limiter straps and hardware

- P/N
95-109 Door pull kit
95-109C Door pull kit - Bowtie
95-109F Door pull kit - Script "F"
95-109M Door pull kit - Pentastar
95-109SW Door pull kit - S&W logo
95-129 Door pull & strap kit
95-129C Door pull & strap kit - Bowtie
95-129F Door pull & strap kit - Script "F"
95-129M Door pull & strap kit - Pentastar
95-129SW Door pull & strap kit - S&W logo

FIVE Designs!



Drive-shaft Loop & Tunnel Kit

- P/N
14-117
14-117MS

- P/N
75-358BLK
 Straps Only

Front Floor & Tunnel

S&W's universal floor & trans tunnel kits are available in steel or aluminum and are perfect for use with S&W's tube chassis door car kits. Each kit includes (4) floor panels, (1) 2 piece, roll formed transmission tunnel and (1) driveshaft tunnel. **Trans Brake Solenoid Cover optional.** All pieces are rolled & bent, some trimming required. Alum. Kits are .040" thick / Steel Kits are .031" thick.

All pieces available A-La-Carte. Call for pricing.

- P/N
95-112 Aluminum Floor & Tunnel kit.
95-114 Aluminum Solenoid cover
95-116 Steel Floor & Tunnel kit.
95-117 Steel Solenoid cover
65-942 Floor & Tunnel button kit

Rear Floor Kits - Direct Fit

S&W now offers rear floor kits in .040 aluminum or lightweight .031" steel for our popular Pro/Series 2000 24", 26" & 28" fully welded ladder bar and 4-link rear frames. Each kit contains the necessary pieces to install a rear floor in most cars from the front of the rear frame rails to the rear bumper. All pieces are slightly oversize and can be trimmed for a custom fit. Kits do not include wheel tubs. Each aluminum kit includes pop rivets for installation (steel kits are welded in) **Aluminum Kits include PVC Protective Coating**

- P/N
10-800 Aluminum for 10-300 series frames (Universal Ladder Bar 24"/26"/28")
10-801 Alum. for 10-400 series & 10-507, 10-508, 10-510 frames (Universal 4-Link 24"/26"/28" & Mustang, Malibu, Camaro 4-Link)
10-803 Quarter turn fastener kit for aluminum floor package
10-804 Steel for 10-300 series frames (Universal Ladder Bar 24"/26"/28")
10-805 Steel for 10-400 series & 10-507, 10-508, 10-510 frames (Universal 4-Link 24"/26"/28" & Mustang, Malibu, Camaro 4-Link)
10-806 Aluminum for 10-502 frame (82-02 Camaro Ladder Bar)
10-807 Steel for 10-502 frame (82-02 Camaro Ladder Bar)
10-808 Aluminum for 10-504 frame (79-04 Mustang Ladder Bar)
10-809 Steel for 10-504 frame (79-04 Mustang Ladder Bar)
10-810 Aluminum for 10-512 frame (68-74 Nova Ladder Bar)
10-811 Steel for 10-512 frame (68-74 Nova Ladder Bar)
10-812 Aluminum for 10-505 frame (78-83 Malibu Ladder Bar)
10-813 Steel for 10-505 frame (78-83 Malibu Ladder Bar)
65-941 Rear Floor Button Kit

Aluminum Dash Kit

S&W Race Cars new aluminum dashboard kit for full bodied "door" cars is available in several configurations.

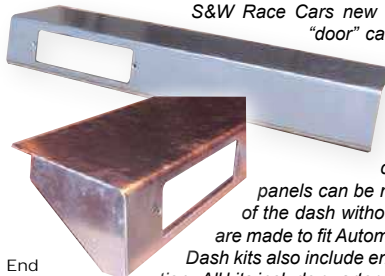

End Caps Included
Coating Included.

All dashboards are 60" wide by 8" tall by 12" deep and can easily be trimmed to fit any make or model. The dash is available without any gauge cutout or with a gauge panel cutout and 4 different configurations of gauge panels. These panels can be mounted in the car and allow for removal of the dash without removing the tach or gauges. Panels are made to fit Autometer tachs and Autometer 2-5/8" gauges. Dash kits also include end cap panels for a neat, finished application. All kits include quarter-turn fasteners, tubing to mount dash plate (when required) and all necessary mounting hardware. **PVC Protective Coating Included.**



- P/N
95-110-0 Dash with no cutout
95-110-1 Dash with cutout and Blank Gauge Panel
95-110-2 Dash with cutout and Tach & 2 Gauge Panel
95-110-3 Dash with cutout and Tach & 3 Gauge Panel
95-110-4 Dash with cutout and Tach & 4 Gauge Panel

Wheel Tubs Alum. & Steel

- P/N
95-391 36" Aluminum **95-374** 34" Steel
95-390 38" Aluminum **95-395** 36" Steel
95-392 40" Aluminum **95-393** 38" Steel
95-397 44" Aluminum **95-394** 40" Steel
95-399 Custom Alum. **95-396** 44" Steel
95-398 Custom Steel

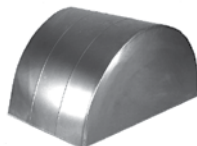

Universal Rear Floor Kits

Universal kits available as .040 aluminum or 20Ga. Steel. **Aluminum Kits include PVC Protective Coating.** All kits include: (2) Center Panels 26"x48", (2) Front Side Panels 22"x20" and (2) Rear Side Panels 22"x28"

- P/N
95-124 Aluminum Kit - .040" th. Coated
95-125 Steel Kit - 20Ga./ .036"th.

Rear Firewall Kit

S&W Race Cars new rear firewall kit closes off the driver's compartment from the trunk area as required by many sanctioning bodies rules. Made of .040" aluminum or 22 gauge steel, this kit includes 2 bulkhead and 2 package tray panels which will install up to 72" wide

- P/N
95-118 Aluminum rear firewall kit (05 & later Mustang)
95-119 Aluminum rear firewall kit (universal)
95-120 Steel rear firewall kit
65-944 Rear firewall button kit

Floor Mounting Strip Kits

Made of 18 gauge steel or .040" aluminum, S&W's floor mounting strips greatly simplify the installation of your floor panel kits. Each kit includes left & right side brackets and all necessary quarter turn fasteners or 10-32 stainless mounting hardware.

- P/N
65-935 Quarter turn fastener floor mount kit (steel)
65-936 Bolt in fastener floor mount kit (steel)
65-938 Quarter turn fastener floor mount kit (aluminum)

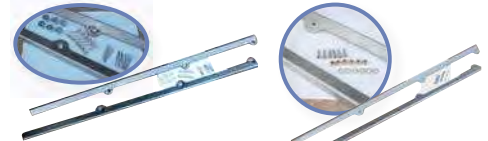

ROLL BARS & ROLL CAGES FOR COMPETITION USE

Look at Your Rulebook!

TECH TIP

S&W Race Cars highly recommends that you consult your racing organization's rule book for proper installation requirements. S&W roll bars and roll cages meet or exceed NHRA, IHRA and most major road race & off-road organization's requirements for material size and thickness, but must be installed in accordance with the sanctioning body's guidelines. (Note: S&W recommends EWS or CM for Drag Race use.)

****S&W Roll Bars & Roll Cages Feature Notched Tube Ends (where applicable) for Ease of Installation****

Available in .134" wall EWS (electric welded seam), .120" wall DOM (drawn over mandrel) or .083" wall 4130 Chrome Moly.

S&W Roll Bars and Cages are available in material sizes that meet the specs of all popular drag race organizations as well as most closed course or drifting car organizations. Keep in mind that it is the installers responsibility to assure that the bar or cage is installed to meet the race organizations rules as to fit or placement of components and welding process.

Part numbers shown are for EWS. To order Chrome Moly add "CM" to the part number. For DOM tubing add "DOM" to the number.

8 Point Roll Bars

S&W roll bars are precision bent from 1-3/4" tubing for each particular body style and feature notched tube ends (where applicable) for ease of installation. Our roll bars are designed to increase chassis stiffness. The kit includes a main hoop, rear braces, side bars, frame supports, seat crossmember and required # of mounting plates.

All S&W roll bars meet or exceed NHRA & IHRA requirements (when properly installed.) See tech tip!

- 8 Point Roll Bars (EWS)
- 8 Point Roll Bars (DOM)
- 8 Point Roll Bars (4130)



All S&W Roll Bars & Roll Cages are \$ ITEMS



Roll Bar & Roll Cage Replacement Pieces on Pg.25

10 Point Roll Cages

S&W 10-point roll cages include all the components of an 8-point roll bar plus roof tubes and windshield crossmember or hoop and windshield post runners.

Made of 1-5/8" steel tubing, S&W roll cages meet or exceed NHRA & IHRA requirements (when properly installed) See tech tip! (SCCA Upgrade on Pg. 24)

Our 10-point roll cages are designed to remain behind the firewall and may require modifications to the stock dashboard. S&W 10 point roll cages feature notched tube ends, where applicable, for ease of installation. Note, because of differing driver sizes and main hoop locations, roof hoop and windshield down bars are not notched!

- 10 Point Roll Cages (EWS)
- 10 Point Roll Cages (DOM)
- 10 Point Roll Cages (4130)

Ask Your Sales Rep. About Style Availability for Your Car or Truck



NOTE:

After choosing your Bar, Cage, or Conversion, please refer to the MAKE & MODEL listings on Pages 26 & 27

LEMONS & CHUMP CAR CAGES

Lemons Car & Chump Car racing is growing in popularity all around the country and S&W now has roll cages for these cars too.

S&W Lemons & Chumps cages are made specifically for the rules that govern Lemons & Chumps cars. The windshield down bars on all drift cages go through the dash. Three options are available depending on desired material type and car weight. Please make sure to consult your rule book before ordering S&W can provide one for all makes & models.



P/N

13-625

Lemons & Chump car cage, 1-5/8" x .134" wall EWS tubing, for cars weighing LESS than 3000#

Must Use Custom Form

13-626

Lemons & Chump car cage, 1-3/4" x .134" wall EWS tubing, for cars weighing MORE than 3000# - can also be used on cars weighing less than 3000#

Must Use Custom Form

13-627

Lemons & Chump car cage, 1-3/4" x .120" wall DOM tubing, "Strongly Recommended" in Lemons rulebook for all cars - approved for most SCCA classes

Must Use Custom Form

ENDURO CAR CAGES

Enduro racing is big in all parts of the country and S&W now has roll cages for Enduro cars too. S&W Enduro cages are made specifically for the rules that govern Enduro racing.

S&W Enduro cages are made of 1-3/4" x .134" wall EWS tubing. The windshield down bars on all Enduro cages go through the dash. S&W can provide one for all makes & models.



Offset Door Bars on Pg.25

DRIFT CAR CAGES

Drifting has quickly become one of America's hottest new sports and S&W now has roll cages for Drift cars too. S&W drift cages are made specifically for the SCCA rules that govern Drift cars.

S&W drift car cages are made of 1-3/4" x .120" wall DOM tubing and feature a crossmember between the rear wheel wells that attach the rear down bars. The windshield down bars on all Drift cages go through the dash. While the two most popular models are listed below, S&W can provide one for all makes & models.

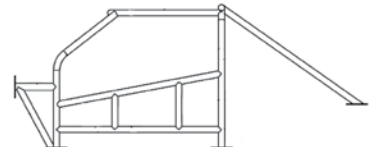

P/N

13-628

Enduro Car Cage

P/N

11-3574DC

11-5594DC

13-629

05-08 Mustang drift car cage

89-94 Nissan 240SX drift car cage

Drift Car Cage - *Must Use Custom Form*



social @SWRACECARS

website SWRACECARS.COM

ROLL BAR & ROLL CAGE UPGRADES - CONVERSIONS

SCCA Cage Upgrade

This Upgrade is for SCCA Racers. This Upgrade must be added to your S&W 10 Point DOM Roll Cage to meet SCCA Racing Specifications. Includes the following in 1-3/4" x .120" DOM Mild Steel

- (1) Main Hoop Diagonal
- (2) Additional Door Bars
- (2) Door Bar Uprights
- (2) Firewall Braces
- (2) 1/8" x 6" x 6" Plates to weld to Firewall.

13-604 SCCA Upgrade

Super Stock Cage Upgrade

This Upgrade is Ideal for those who compete in Super Stock Drag Racing Classes or anyone looking to 'Lighten Up' their 10 point S&W Chrome Moly Roll Cage. The existing 1-5/8" x .083" wall Chrome Moly Tubes are replaced with the following:

- Seat Crossmember - 1-1/4" x .065" wall Chrome Moly Tube
- Lateral Support - 1-1/4" x .058" wall Chrome Moly Tube
- Dash Bar - 1-1/4" x .058" wall Chrome Moly Tube

13-006 SS Upgrade

Full Cage "Sportsman" Upgrade

Any S&W roll cages can be upgraded to a with the addition of a S&W cage upgrade. Included in this package are front subframe supports, door x-braces, rear x-brace behind the driver and left & right side rocker bars.

All components are notched where possible and constructed to meet or exceed N.H.R.A. and I.H.R.A. requirements. To order a roll cage upgrade, order the 10 point cage for your application plus



- 13-349 Mild Steel (EWS)
- 13-317 Mild Steel (DOM)
- 13-606 Chrome Moly Steel (4130)

Roll Cage Upgrade Components

The following S&W roll cage components are available for racers that want to add additional tubing to their 10 point roll cage.

P/N

- 13-350 Front Sub-frame supports - a-arm
- 13-356 Front Sub-frame supports - a-arm (DOM)
- 13-358 Front Sub-frame supports - strut type
- 13-352 X-brace behind driver
- 13-353 Roll Bar Mounting Pad, each (6" x 6" x 1/8")
- 13-355 Door X-brace conversion (2 doors)
- 13-360 82-92 Camaro/Firebird side bar package for stock inner door panels - 1-5/8"
- 13-361 82-92 Camaro/Firebird side bar package for stock inner door panels - 1-3/4"
- 13-369 Seat belt mounting kit - 1/2" hardware
- 13-608 Front Sub-frame supports - a-arm (chrome-moly)
- 13-616 Front Sub-frame supports - strut type (chrome-moly)

The parts listed above are also available in chrome moly and D.O.M tubing. Please contact your S&W sales representative for more info

13-350 Front Sub Frame Supports

Also shown:

13-352 X Brace behind driver

13-355 Door X Brace conversion

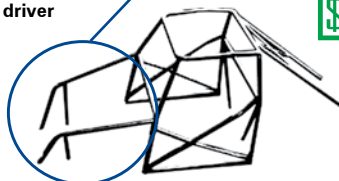

All S&W Roll Bar & Roll Cage Upgrades are \$ ITEMS

Roll Bar to Cage Conversion

S & W conversion kits are designed to convert an existing 8-point roll bar into a 10-point roll cage.

This kit includes roof tubes, windshield post runners and dash crossmember. Made of 1-5/8" steel tubing, these conversion kits meet or exceed the NHRA & IHRA requirement for roll cage tubing.

Note: Because of differing driver sizes and main hoop locations, this kit is not notched!



- 10 Point Cage Conv. (EWS)
- 10 Point Cage Conv. (DOM)
- 10 Point Cage Conv. (4130)

NOTE:

After choosing your Bar, Cage, or Conversion, please refer to the MAKE & MODEL listings on Pages 18 & 19

Funny Car Cage Conversion

S & W Race Cars funny car cage conversion kit includes all tubing necessary to upgrade your existing roll cage to the latest in doorslammer cages.

This kit can be easily installed in virtually any existing roll cage or doorslammer tube chassis.

The tubing is left long so that it can be cut to fit exactly to your chassis. Funny car cage conversions are available in 1-5/8" x .134" wall mild steel or in 1-5/8" x .083" wall chrome moly tubing.

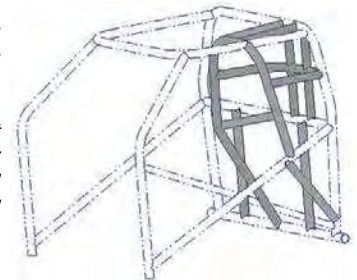

- 13-362 F/C Cage Conv.(Mild Steel)
- 13-363 F/C Cage Conv.(Chrome Moly)
- 13-379 F/C Cage Conv. (UltraLite Weight CM)

Funny Car Cage conversion includes all shaded tubing shown in drawing.

Pro Street Rear Runners

Pro Street style rear runners are available for all S&W roll bars and roll cages. These rear runners are designed to go through the rear package shelf and require no modification to the rear seat.

Note: This kit is not notched!



- 13-RearRunner-EWS Mild Steel (EWS)
- 13-RearRunner-DOM Mild Steel (DOM)
- 13-RearRunner-CM Chrome Moly

Part # varies by application - Please call for more information

Sfi 25.1(E) Cockpit Conversion

Converts Back-Halved and S&W Round Tube Chassis to Sfi 25.1E Specification. (for Advanced Chassis Builders)

Call your Sales Representative to discuss details.

- 13-364 To Fit Back-Halved Chassis
- 13-365 To Fit Round Tube Chassis
- 13-380 Sfi 25.4 Upgrade

ROLL BAR & ROLL CAGE REPLACEMENT PIECES

We Have Your Back!
S&W now offers individual Roll Bar & Roll Cage Replacement Pieces.

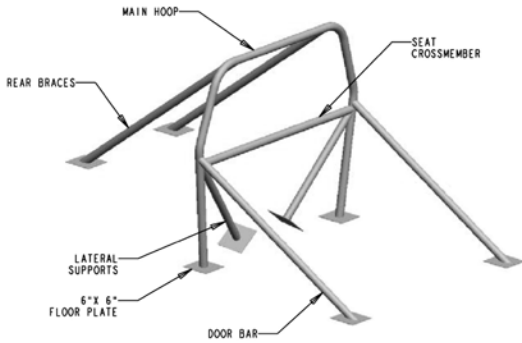

- Main Hoops
- Roof Hoops
- Side Bars
- Back Bars
- Dash Bars
- Diagonal Bars
- Lateral Supports
- Seat Crossmembers
- Windshield Runners

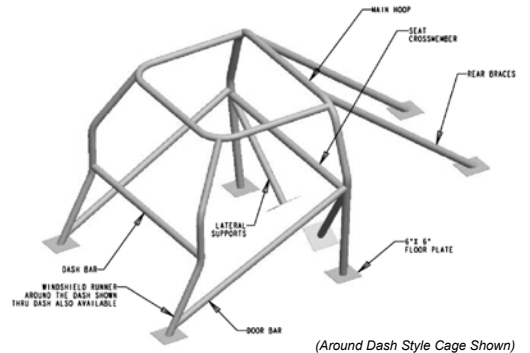

(Around Dash Style Cage Shown)



WELD-IN 4-POINT 'STREET BAR' / OFFSET & DROPPED SIDE BARS

S&W's WELD-IN 'STREET BARS' are available for many makes & models of cars and trucks. Specify Make & Model when ordering. See Chart Pg 26 - 28. Features notched Tube Ends for ease of installation. **NOTE: NOT Approved for Competition Use!!**

4-POINT WELD-IN 'Street' Bar

Kit Includes: Main Hoop, (2) Pre-Notched Back Bars, Pre-Notched Seat Crossmember and (4) 1/8" Floor Plates. Specify vehicle make & model.



- P/N 13-400 Weld-In 4 Point Street Roll Bar EWS
- 13-400DOM Weld-In 4 Point Street Roll Bar DOM
- 13-400CM Weld-In 4 Point Street Roll Bar CM

Dropped 'Street' Side Bar

Kit Includes: Tubing 27" High at Back, 14" High Center Section, 44" Long Pair.

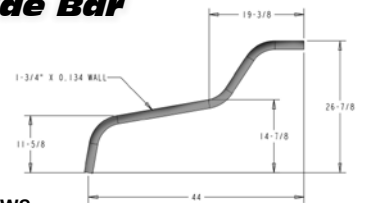

- P/N 13-410 Dropped Street Side Bar EWS
- 13-410DOM Dropped Street Side Bar DOM
- 13-410CM Dropped Street Side Bar CM

OFFSET DOOR BAR SET - NASCAR STYLE

Includes: (2) Door Bars & (2) Uprights

- P/N 13-631 1-3/4" EWS
- P/N 13-630 1-5/8" EWS
- P/N 13-632 1-3/4" DOM



TRUCK & SUV 'FAMILY BARS'

'Family Bars' Rear Roll Cage Kits

When used in conjunction with the appropriate S&W's 10 point roll cage, this tubing package offers additional protection to the rear seat passengers.

Shown as dark tubing in the photo, this package includes two additional EWS Crossmembers (one at the roof and one behind the rear seat) and formed rear down runners.



- P/N (EWS)
- 13-1519 73-87 Blazer
- 13-1581 94-02 Blazer
- 13-3560 78- newer Bronco
- 13-3588 02-07 Explorer
- 13-5542 07 Toyota FJ

See Page 20 for Complete Listing of Truck / SUV Roll Bars & Roll Cages!



social @SWRACECARS

website SWRACECARS.COM

DOMESTIC CAR MAKE/MODEL LISTING - ROLL BARS & ROLL CAGES

NOTE: Part Numbers shown are for EWS Tubing. - For DOM Tubing: add "DOM" after the number. - For Chrome Moly Tubing: add "CM" after the part number.

General Motors

8-Point Roll Bar P/N	10-Point Roll Cage P/N	Roll Cage Conversion P/N	
11-1000	11-1500	12-1000	67-69 Camaro, Firebird
	11-1500R	12-1000R	67-69 Camaro, Firebird. runner style
11-1001	11-1501	12-1001	70-81 Camaro, Firebird
11-1013	11-1513	12-1013	82-92 Camaro, Firebird
	11-1513TD	12-1013TD	82-92 Camaro, Firebird thru dash
11-1030	11-1530	12-1030	93-02 Camaro, Firebird
	11-1530TD	12-1030TD	93-02 Camaro, Firebird, thru dash
11-1034	11-1534TD		2010 & Newer Camaro - Hard Top Only
11-1002	11-1502	12-1002	64-67 Chevelle, GTO, Skylark, 442
11-1003	11-1503	12-1003	68-72 Chevelle, GTO, Skylark, 442,
11-1089	11-1589	12-1089	73-77 Chevelle, Monte, & Cutlass
11-1004	11-1504	12-1004	55-57 Chevy
11-1005	11-1505	12-1005	62-67 Chevy II
	11-1505R	12-1005R	62-67 Chevy II runner style
11-1006	11-1506	12-1006	58-62 Corvette
11-1007	11-1507	12-1007	63-67 Corvette
11-1008	11-1508	12-1008	68-83 Corvette
11-1009	11-1509	12-1009	84-96 Corvette Coupe
11-1009FT	11-1509FT	12-1009FT	84-96 Corvette Convertible
11-1022			97-04 Corvette Coupe
	11-1522TD	12-1022TD	97-04 Corvette Coupe thru dash
11-1010	11-1510	12-1010	68-78 Nova, Ventura
	11-1510R	12-1010R	68-78 Nova, Ventura runner style
11-1011	11-1511	12-1011	Vega, Monza
11-1012	11-1512	12-1012	S&W 10-505 frame
11-1014	11-1514	12-1014	87-96 Beretta
11-1088	11-1588	12-1088	87 & earlier Cavalier
11-1015	11-1515	12-1015	88-95 Cavalier
	11-1515TD	12-1015TD	88-95 Cavalier thru dash
11-1021	11-1521	12-1021	95-01 Cavalier
	11-1521TD	12-1021TD	95-01 Cavalier thru dash
11-1024	11-1524	12-1024	04-06 Pontiac GTO
	11-1524TD	12-1024TD	04-06 Pontiac GTO thru dash
11-1025	11-1525	12-1025	04-10 Cobalt
	11-1525TD	12-1025TD	04-10 Cobalt thru dash
11-1027	11-1527	12-1027	59-60 El Camino
11-1016			78-83 Malibu & 78-88 Monte Carlo
	11-1516TD	12-1016TD	78-83 Malibu & 78-88 Monte Carlo thru dash
11-1031	11-1531	12-1031	95-99 Monte Carlo
	11-1531TD	12-1031TD	95-99 Monte Carlo thru dash
11-1028	11-1528	12-1028	53-54 Chevy 2 door post sedan
11-1029	11-1529	12-1029	65-69 Corvair
11-1032	11-1532TD	12-1032TD	94-97 Olds Cutlass thru dash
11-1018	11-1518	12-1018	84-88 Celebrity
11-1098	11-1598	12-1098	61-64 Impala
11-1020	11-1520	12-1020	65-69 Impala
11-1099	11-1599	12-1099TD	70-80 Impala
11-1084	11-1584	12-1084	91-96 Caprice & 94-96 Impala
	11-1584TD	12-1084TD	91-96 Caprice & 94-96 Impala - thru dash
11-1086	11-1586	12-1086	37-39 Chevy Coupe
11-1087			37-39 Chevy Sedan
11-1091	11-1591	12-1091	68-73 Opel GT
11-1093	11-1593	12-1093	70-72 Monte Carlo
11-1094			63 Tempest
11-1095	11-1595	12-1095	82 Buick Skylark
11-1097	11-1597	12-1097	Chevette (also fits Toyota Starlet)
11-1033	11-1533	12-1033	60-64 Corvair
11-1042	11-1542	12-1042	2005-2010 Pontiac G6
	11-1542TD	12-1042TD	2005-2010 Pontiac G6 - thru dash
11-1035	11-1535	12-1035	1958 Chevy
11-1036	11-1536	12-1036	1934 Chevy Coupe
11-1082			2000-2005 Saturn L Series
	11-1582TD		2000-2005 Saturn L Series - thru dash
11-1083	11-1583	12-1083	1998-2002 Saturn S Series Coupe
	11-1583TD		1998-2002 Saturn S Series Coupe - thru dash

FORD Motor Company

8-Point Roll Bar P/N	10-Point Roll Cage P/N	Roll Cage Conversion P/N	
11-3059	11-3559	12-3059	69-77 Maverick
11-3056	11-3556TD	12-3056TD	69-78 Mercury Capri
11-3061	11-3561	12-3061	64-68 Mustang & Cougar
11-3062	11-3562	12-3062	69-73 Mustang & Cougar
11-3063	11-3563	12-3063	Pinto
11-3064	11-3564	12-3064	Fairmont, Futura
11-3065	11-3565	12-3065	74-78 Mustang II
11-3066	11-3566	12-3066	79-93 Mustang
	11-3566TD	12-3066TD	79-93 Mustang thru dash
	11-3566TDR	12-3066TDR	79-93 Mustang thru dash, runner style
11-3066FT	11-3566FT	12-3066FT	79-93 Mustang Conv.
	11-3566FTTD	12-3066FTTD	79-93 Mustang Conv. thru dash
11-3079	11-3579	12-3079	94-04 Mustang GT Hardtop
	11-3579TD	12-3079TD	94-04 Mustang GT Hardtop thru dash
11-3074	11-3574	12-3074	2005-2014 Mustang
	11-3574TD	12-3074TD	2005-2014 Mustang thru dash
11-3094	11-3594	12-3094	2015 & Newer Mustang
	11-3594TD	12-3094TD	2015 & Newer Mustang thru dash
	11-3574DC		2005-2014 Mustang Drift Car Cage
11-3076			55-56-57 Thunderbird
11-3075	11-3575	12-3075	68 Thunderbird
11-3067	11-3567	12-3067	83-88 T-bird and Cougar
11-3068	11-3568	12-3068	89-96 T-bird and Cougar
11-3069	11-3569	12-3069	66-67 Fairlane, Comet
11-3070	11-3570	12-3070	60-65 Falcon, 62-65 Fairlane, Comet
11-3072			72-76 Torino
11-3073			70 Cyclone
11-3077	11-3577	12-3077	32 Ford Coupe
11-3087	11-3587	12-3087	33-34 Ford Coupe
11-3058	11-3558	12-3058	37 Ford Coupe
11-3078	11-3578	12-3078	48-53 Anglia
11-3080	11-3580	12-3080	92-96 Escort
11-3082	11-3582	12-3082	1998-2004 Focus
	11-3582TD	12-3082TD	1998-2004 Focus thru dash
11-3093	11-3593TD	12-3093TD	2011 & Newer Focus
11-3085	11-3585	12-3085	60-61 Fairlane
11-3086	11-3586	12-3086	60-64 Galaxy
11-5051	11-5551	12-5051	93-97 Ford Probe
11-3057	11-3557TD	12-3057TD	85-89 Ford Merkur
11-3055	11-3555	12-3055	1959-1968 Ford Anglia

Chrysler Corp. & A.M.C.

P/N	P/N	P/N	
11-2022	11-2522	12-2022	70-74 Cuda & Challenger
11-2024	11-2524	12-2024	76-80 Aspen, Volare
11-2025	11-2525	12-2025	1984-1993 Dodge Daytona, Plymouth Laser - K Body
11-2026	11-2526	12-2026	Plymouth Arrow
11-2028	11-2528TD	12-2028TD	94-2000 Chrysler Sebring thru dash
11-2029	11-2529	12-2029	1977-1990 Dodge Omni, Plymouth Horizon
11-2030	11-2530	12-2030	64-66 Barracuda & Valiant
11-2050	11-2550R	12-2550R	2008 & Newer Challenger
11-2031	11-2531	12-2031	67-69 Barracuda
11-2032	11-2532	12-2032	70-76 Duster, Demon, Dart Sport
11-2033	11-2533	12-2033	65-66 Dart
11-2034	11-2534	12-2034	67-72 Dart, Scamp, Swinger
11-2035	11-2535	12-2035	62-64 Polara & 330 B-Body
11-2036	11-2536	12-2036	66-67 Coronet, Satellite, Charger, R/T, GTX, Belvedere
11-2037	11-2537	12-2037	68-70 Coronet, Satellite, Charger, R/T, GTX, Belvedere, Road Runner, Super Bee
11-2038	11-2538	12-2038	71-72 Coronet, Satellite, Charger, R/T, GTX, Belvedere, Road Runner, Super Bee
11-2039	11-2539	12-2039	73-75 Coronet, Satellite, Charger, R/T, GTX, Belvedere, Road Runner, Super Bee
11-2040	11-2540	12-2040	94-05 Neon 2 door
	11-2540TD	12-2040TD	94-05 Neon 2 door thru dash
11-2040SRT	11-2540SRT	12-2040SRT	03-05 Neon SRT
11-2041	11-2541	12-2041	94 Dodge Stealth
11-2043	11-2543	12-2043	63-65 Belvedere, Coronet
11-2051	11-2551	12-2051	2006-2014 Dodge Charger
	11-2551TD	12-2051TD	2006-2014 Dodge Charger thru dash
11-2081	11-2581	12-2081	68-70 AMX, Javelin
11-2084	11-2584	12-2084	71-74 AMX, Javelin
11-2082			79 AMC Spirit
11-2083			70 AMC Hornet
11-2092	11-2592	12-2092	70-78 AMC Gremlin
11-2020FT	11-2520FT	12-2020	82-88 LeBaron Convertible
11-2044	11-2544	12-2044	95-99 Eagle Talon
	11-2544TD	12-2044TD	95-99 Eagle Talon - thru dash
11-2045	11-2545	12-2045	94 Eagle Summit
11-2047	11-2547	12-2047	90-94 Eagle Talon

Other Domestic Applications

P/N	P/N	P/N	
11-1023	11-1523	12-1023	47 Nash Super 600
11-4052	11-4552	12-4052	47 International Truck
11-4074	11-4574	12-4074	Henry J
11-4095	11-4595	12-4095	33 Willys with chopped top
11-4096	11-4596	12-4096	40 Willys
11-5059	11-5559	12-5059	Geo Storm
11-4053			1954 Studabaker Commander
	11-4553TD	12-4053TD	1954 Studabaker Commander - thru dash



IMPORT CAR MAKE/MODEL LISTING - ROLL BARS & ROLL CAGES

DON'T SEE YOUR CAR or Truck LISTED?
CUSTOM DESIGNED ROLL BARS & ROLL CAGES are our Specialty!
We'll Bend One Just For You!!

S&W Race cars has one of the largest inventories of roll bars and roll cages anywhere, but if you don't see your application listed in this catalog - Please call us! We can make a roll bar or cage to your specifications. Roll bars and cages are available in mild steel or chrome moly.

Ask us for a Data Sheet. Your information will be reviewed by S&W's Engineering Department and turned into a CAD Drawing that's production ready!

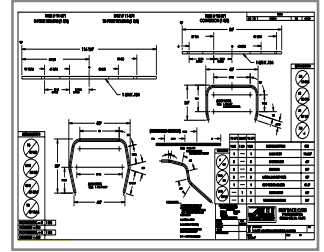

NOTE: Part Numbers shown are for EWS Tubing. - For DOM Tubing: add "DOM" after the number. - For Chrome Moly Tubing: add "CM" after the part number.

8-Point Roll Bar P/N	10-Point Roll Cage P/N	Roll Cage Conversion P/N	
Acura			
11-5054	11-5554	12-5054	90-93 Acura Integra
	11-5554TD	12-5054TD	90-93 Acura Integra thru dash
11-5065	11-5565	12-5065	94-01 Acura Integra
Audi			
11-5038	11-5538	12-5038	2003 - present Audi A3
	11-5538TD	12-5038TD	2003 - present Audi A3 thru dash
BMW			
11-5039	11-5539	12-5039	92-99 BMW E36
	11-5539TD	12-5039TD	92-99 BMW E36 thru dash
11-5043	11-5543	12-5043	84-91 BMW 325i
11-5084	11-5584	12-5084	81-88 BMW 5 Series E28
BMW MINI COOPER			
11-5009	11-5509	12-5009	2001-2014 BMW MINI Hatch, Hardtop & Clubman
	11-5509TD	12-5009TD	2001-2014 BMW MINI - thru dash
Honda			
11-5021	11-5521	12-5021	1994-1997 Honda Accord
	11-5521TD	12-5021TD	1994-1997 Honda Accord thru dash
11-5047	11-5547	12-5047	2003-07 Honda Accord
	11-5547TD	12-5047TD	2003-07 Honda Accord thru dash
11-5056	11-5556	12-5056	1996-2000 Honda Civic
	11-5556TD	12-5056TD	1996-2000 Honda Civic thru dash
11-5057	11-5557	12-5057	88-91 Honda CRX
11-5058	11-5558	12-5058	92- 95 Honda Civic Hatchback
	11-5558TD	12-5058TD	92- 95 Honda Civic Hatchback thru dash
11-5062	11-5562	12-5062	90-93 Honda Accord
	11-5562TD	12-5062TD	90-93 Honda Accord thru dash
11-5072	11-5572	12-5072	97 & later Honda Prelude
	11-5572TD	12-5072TD	97 & later Honda Prelude thru dash
11-5078	11-5578TD	12-5078TD	88-91 Honda Civic
11-5081	11-5581	12-5081	93-97 Honda Del Sol
	11-5581TD	12-5081TD	93-97 Honda Del Sol thru dash
11-5083	11-5583TD	12-5083TD	99-09 Honda S2000 thru dash
Hyundai			
11-5046	11-5546	12-5046	2005 Hyundai Tiburon
	11-5546TD	12-5046TD	2005 Hyundai Tiburon thru dash
Lexus			
11-5074	11-5574	12-5074	92-97 Lexus SC400
	11-5574TD	12-5074TD	92-97 Lexus SC400 thru dash
11-5045	11-5545	12-5045	2000-05 Lexus IS300
	11-5545TD	12-5045TD	2000-05 Lexus IS300 thru dash
Mazda			
11-5088	11-5588	12-5088	98-2005 Mazda Miata
11-5036	11-5536	12-5036	89-97 Mazda Miata
11-5041	11-5541	12-5041	77-85 Mazda GLC
11-5049	11-5549	12-5049	69 Mazda R100
11-5051	11-5551	12-5051	93-97 Mazda MX6 (some Ford Probe)
11-5040	11-5540	12-5040	79-85 Mazda RX7
	11-5540TD	12-5040TD	79-85 Mazda RX7 thru dash
11-5052	11-5552	12-5052	92-2002 Mazda RX7
	11-5552TD	12-5052TD	92-2002 Mazda RX7 thru dash
11-5066	11-5566	12-5066	86-91 Mazda RX7
	11-5566TD	12-5066TD	86-91 Mazda RX7 thru dash
11-5085	11-5585	12-5085	98-03 Mazda Protege
11-5066	11-5589	12-5089	89-96 Mazda 323
	11-5589TD	12-5089TD	89-96 Mazda 323 thru dash
Kia			
11-5011	11-5511	12-5011	2009-2013 Kia Soul
	11-5511TD	12-5011TD	2009-2013 Kia Soul thru dash
Mitsubishi			
11-2041	11-2541	12-2041	94 Mitsubishi 3000GT
11-2044	11-2544	12-2044	95-99 Mitsubishi Eclipse
11-2047	11-2547	12-2047	90-94 Mitsubishi Eclipse
11-5073	11-5573	12-5073	2003-04 Mitsubishi Lancer EVO
	11-5573TD	12-5073TD	2003-04 Mitsubishi Lancer EVO thru dash

8-Point Roll Bar P/N	10-Point Roll Cage P/N	Roll Cage Conversion P/N	
Datsun / Nissan			
11-5092	11-5592		84-98 Nissan 200SX
11-5094	11-5594	12-5094	89-94 Nissan 240SX
	11-5594TD	12-5094TD	89-94 Nissan 240SX thru dash
	11-5594DC		89-94 Nissan 240SX Drift Car Cage
11-5095	11-5595	12-5095	Datsun 240-Z
11-5055	11-5555	12-5055	84-89 Datsun 300ZX
11-5061	11-5561	12-5061	89-94 Nissan Skyline
	11-5561TD	12-5061TD	89-94 Nissan Skyline thru dash
11-5093	11-5593TD	12-5093TD	90-96 Nissan 300ZX thru dash
11-5096	11-5596	12-5096	2003 Nissan 350Z
	11-5596TD	12-5096TD	2003 Nissan 350Z thru dash
11-5097	11-5597	12-5097	95-98 Nissan 240SX
	11-5597TD	12-5097TD	95-98 Nissan 240SX thru dash
11-5098	11-5598	12-5098	71-73 Datsun 1200 / B110
Subaru			
11-5071	11-5571	12-5071	93-2001 Subaru Impreza 2dr.
	11-5571TD	12-5071TD	93-2001 Subaru Impreza 2dr. thru dash
11-5080	11-5580	12-5080	02-2006 Subaru Impreza 2dr.
	11-5580TD	12-5080TD	02-2006 Subaru Impreza 2dr. thru dash
11-5028	11-5528	12-5028	2011 - 2016 Subaru WRX
	11-5528TD	12-5028TD	2011 - 2016 Subaru WRX thru dash
SAAB			
11-5022	11-5522TD	12-5022TD	2003-2014 SAAB 9.3
11-5090	11-5590		1980-1993 SAAB 900
	11-5590TD		1980-1993 SAAB 900 thru dash
Toyota			
11-1097	11-1597	12-1097	Toyota Starlet
11-5026	11-5526	12-5026	1970-1974 Toyota Corolla
11-5076	11-5576TD	12-5076TD	78 Toyota Corolla thru dash
11-5091	11-5591	12-5091TD	79-83 Toyota Corolla Hatchback
11-5044	11-5544	12-5044	80-83 Toyota Corolla
11-5048	11-5548	12-5048	84-87 Toyota Corolla RWD
	11-5548TD	12-5048TD	84-87 Toyota Corolla RWD thru dash
11-5053			94-98 Toyota Supra
11-5070	11-5570	12-5070	86-1/2-92 Toyota Supra
	11-5570TD	12-5070TD	86-1/2-92 Toyota Supra thru dash
11-5079	11-5579	12-5079	91-95 Toyota MR2
	11-5579TD	12-5079TD	91-95 Toyota MR2 thru dash
11-5086	11-5586		96-99 Toyota Paseo
Triumph			
11-5008	11-5508TD	12-5008TD	1978-1981 Triumph TR7 & TR8
Volkswagen			
11-5050	11-5550	12-5050	Volkswagen Beetle (original style)
11-5060	11-5560	12-5060	Volkswagen Rabbit
	11-5560TD	12-5060TD	Volkswagen Rabbit thru dash
11-5063	11-5563	12-5063	93-99 Volkswagen Jetta
	11-5563TD	12-5063TD	93-99 Volkswagen Jetta thru dash
11-5025	11-5525TD	12-5025	74-81 Volkswagen Scirocco
11-5064	11-5564	12-5064	82-88 Volkswagen Scirocco
	11-5564TD	12-5064TD	82-88 Volkswagen Scirocco thru dash
11-5067	11-5567	12-5067	84-92 Volkswagen Jetta
	11-5567TD	12-5067TD	84-92 Volkswagen Jetta thru dash
11-5068	11-5568	12-5068	89-93 Volkswagen Corrado
	11-5568TD	12-5068TD	89-93 Volkswagen Corrado thru dash
11-5069	11-5569	12-5069	85-92 VW Golf GTI 2 door
	11-5569TD	12-5069TD	85-92 VW Golf GTI 2 door thru dash
11-5023	11-5523	12-5023	91-2002 VW Golf GTI
	11-5523TD	12-5023TD	91-2002 VW Golf GTI thru dash
11-5077	11-5577	12-5077	87-93 VW Fox
	11-5577TD	12-5077TD	87-93 VW Fox thru dash
11-5087	11-5587TD	12-5087TD	2000 & Newer VW Jetta
Volvo			
11-5030	11-5530	12-5030	740 Series Volvo
	11-5530TD	12-5030TD	740 Series Volvo thru dash
11-5027	11-5527TD		2000-2009 Volvo S60 thru dash
11-5029	11-5529TD		200, 240 & 260 Series Volvo
11-5087	11-5587TD	12-5087TD	2000 & Newer VW Jetta



All S&W
Roll
Bars, Roll
Cages &
Conversions
are \$ ITEMS



TRUCK / SUV / 4X4 OffRoad → ROLL BARS & ROLL CAGES

Available in .134" wall EWS (electric welded seam), 120" wall DOM (drawn over mandrel) or .083" wall 4130 chrome moly, S&W roll bars and cages are available in material sizes that meet the specs of all popular drag race organizations as well as most closed course or drifting car organizations. Keep in mind that it is the installers responsibility to assure that the bar or cage is installed to meet the race organizations rules as to fit or placement of components and welding process.



All S&W TRUCK / SUV / 4X4 Roll Bars, Roll Cages & Conversions are \$ ITEMS

- **8 Point Roll Bars (EWS)**
- **8 Point Roll Bars (DOM)**
- **8 Point Roll Bars (4130)**

- **10 Point Roll Cages (EWS)**
- **10 Point Roll Cages (DOM)**
- **10 Point Roll Cages (4130)**

General Motors 'Truck/SUV'

8-Point Roll Bar P/N	10-Point Roll Cage P/N	Roll Cage Conversion P/N	
11-1017	11-1517 11-1517X 11-1517TD 11-1517XTD	12-1017 12-1017X 12-1017TD 12-1017XTD	82-93 S-10 82-93 S-10 Pickup extended cab 82-93 S-10 thru dash 82-93 S-10 Pickup ext.cab thru dash
11-1026	11-1526 11-1526TD	12-1026 12-1026TD	82-93 S-10 Blazer only 82-93 S-10 Blazer only - thru dash
11-1080	11-1580	12-1080	94-02 S-10 Pickup
11-1080	11-1580X 11-1580TD	12-1080X 12-1080TD	94-02 S-10 Pickup extended cab 94-02 S-10 Pickup thru dash
11-1081	11-1580XTD 11-1581 11-1581TD	12-1080XTD 12-1081 12-1081TD	94-02 S-10 Pickup ext.cab thru dash 94-02 S-10 Blazer only 94-02 S-10 Blazer only - thru dash
11-1092	11-1592	12-1092	Luv pickup
11-1096	11-1596	12-1096	47-55 Chevy Pickup
11-1090	11-1590	12-1090	67-72 Chevy Pickup, Blazer
11-1019	11-1519	12-1019	73-90 Chevy Pickup, Blazer
11-1040	11-1540 11-1540TD	12-1040 12-1040TD	88-98 Chevy Pickup 88-98 Chevy Pickup thru dash
11-1041	11-1541 11-1541TD	12-1041 12-1041TD	99-2006 Chevy-GMC Pickup 99-2006 Chevy-GMC Pickup thru dash
11-1085	11-1585 11-1585TD	12-1085 12-1085TD	2006 Hummer H-3 2006 Hummer H-3 thru dash
11-1038	11-1538	12-1038	1985-1994 Astro Van

Chrysler Corp. & A.M.C. 'Truck/SUV'

8-Point Roll Bar P/N	10-Point Roll Cage P/N	Roll Cage Conversion P/N	
11-2027	11-2527	12-2027	87-96 Dodge Dakota Pickup
11-2090	11-2590 11-2590TD	12-2090 12-2090TD	Chrysler PT Cruiser Chrysler PT Cruiser thru dash
11-2046	11-2546	12-2046	81-93 Dodge Pickup
11-2049	11-2549 11-2549TD	12-2049 12-2049TD	94-01 Dodge Ram Pickup 95-01 Dodge Ram Pickup thru dash
11-2048	11-2548 11-2548TD	12-2048 12-2048TD	02-05 Dodge Ram Pickup 02-05 Dodge Ram Pickup thru dash
11-2042	11-2542	12-2042	Jeep Wrangler YJ
11-2021	11-2521	12-2021	Jeep CJ-5
11-2085	11-2585	12-2085	Jeep CJ-7
11-2087	11-2587	12-2087	Jeep Cherokee
11-2088	11-2588	12-2088	Jeep Jeepster
11-2088	11-2588	12-2088	Jeep Commando - all years
11-2023	11-2523 11-2523TD	12-2023 12-2023TD	2001-05 Jeep Liberty 2001-05 Jeep Liberty thru dash
11-2019	11-2519TD	12-2019TD	1998-2003 Dodge Durango 1998-2003 Dodge Durango thru dash

Other Domestic 'Truck/SUV'

8-Point Roll Bar P/N	10-Point Roll Cage P/N	Roll Cage Conversion P/N	
11-4052	11-4552	12-4052	47 International Truck

- **10 Point Cage Conversion (EWS)**
- **10 Point Cages Conversion (DOM)**
- **10 Point Cages Conversion (4130)**

NOTE:

Part Numbers shown are for EWS Tubing.

DOM Tubing: add "DOM" after the number.

Chrome Moly Tubing: add "CM" after the part number.

Jeep "TJ" & "YJ" Roll Cage Conversion

TJ & YJ fans, now you can convert your Jeep to a full roll cage with S&W's new TJ or YJ conversion kits! This kit mounts to the OEM roll bar and replaces the factory windshield support tubes with a real roll cage. Kit is made of 1-3/4" x .120" DOM tubing and includes; down runners, windshield crossmember, dash crossmember, roof tubes and floor pads. Welding is required for installation.



P/N

- 12-2086 DOM TJ roll cage conversion kit
- 12-2089 DOM YJ roll cage conversion kit



Dale Burrow

Ford Motor Co. 'Truck/SUV'

8-Point Roll Bar P/N	10-Point Roll Cage P/N	Roll Cage Conversion P/N	
11-3060	11-3560	12-3060	73-79 F150 Pickup
11-3060	11-3560	12-3060	78-79 Bronco
11-3071	11-3571 11-3571TD	12-3071 12-3071TD	83-92 Ranger Pickup 83-92 Ranger Pickup thru dash
11-3092	11-3592		93-2011 Ranger Pickup
11-3081	11-3581	12-3081	92-96 F-150 & Lightning
11-3083	11-3583	12-3083	68-76 Bronco - runner style
11-3084	11-3584	12-3084	97-03 F-150 Pick Up
11-3088	11-3588 11-3588TD	12-3088 12-3088TD	02-07 Explorer / Mountaineer 02-07 Explorer / Mountaineer thru dash
11-3089	11-3589 11-3589TD	12-3089 12-3089TD	80-91 F Series Pick up 80-91 F Series Pick up thru dash
11-3090	11-3590	12-3090	1934 Ford Pick Up
11-3091	11-3591 11-3591TD	12-3091 12-3091TD	99 & Newer Ford Super Duty Pick Up 99 & Newer Ford Super Duty Pick Up thru dash

Toyota 'Truck/SUV'

8-Point Roll Bar P/N	10-Point Roll Cage P/N	Roll Cage Conversion P/N	
11-5010	11-5510	12-5010	1988-1997 Toyota Pickup
	11-5510TD	12-5010TD	1988-1997 Toyota Pickup thru dash
11-5042	11-5542 11-5542TD	12-5042 12-5042TD	2007 Toyota FJ 2007 Toyota FJ thru dash
11-5075	11-5575	12-5075	88 Toyota Pickup
	11-5575TD	12-5075TD	88 Toyota Pickup thru dash
11-5082	11-5582 11-5582TD	12-5082 12-5082TD	95-04 Toyota Tacoma Pickup 95-04 Tacoma Pickup thru dash



Swing Out Side Bar Kit

S & W Race Cars swing out side-bar kit makes it easy to convert your existing side bar to a more convenient swing out model. This kit makes it easier to enter or exit your race car. This kit fits both 1-5/8" and 1-3/4" side bars and all necessary hardware is included. Each kit does one door side bar. Be sure to check your sanctioning body's rule book for acceptance and installation requirements.

P/N

- 13-357 Swing out side bar kit (Each)
- 13-357P Swing out side bar kit (Pair)

13-357 (shown) Unassembled



Carbon Fiber Tube Protectors

Carbon Fiber Tube Protectors - 59" Long - Sold Each

P/N

- 95-780 Fits 1-1/4" to 1-1/2" Diam. Tube
- 95-781 Fits 1-3/4" to 2-1/4" Diam. Tube
- 95-782 Fits 1-5/8" to 2" Diam. Tube



Interlocking Roll Bar Tube Clamp

Acceptable for SCCA Bolt-In Roll Cages

P/N

- 13-381 Fits 1-3/4" x .120 wall tubing



Floor Seal Plates

22 gauge steel plates make it easy to reseal the floor pan around roll bar & roll cage tubes on full frame cars where it is necessary to cut a larger hole to weld the bar or cage to the frame. Available in 2 sizes and for 1-5/8" or 1-3/4" diameter tubing. Sold in pairs.

P/N

- 13-374 Floor seal plate 6" x 6" - 1-5/8"
- 13-375 Floor seal plate 10" x 10" - 1-5/8"
- 13-376 Floor seal plate 6" x 6" - 1-3/4"
- 13-377 Floor seal plate 10" x 10" - 1-3/4"

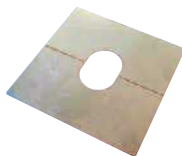

Roll Cage Gussets

P/N

- 13-351 Gussets - Package of 25
- 13-370 4130 round tube gusset set
- 13-354 Mild Steel round tube gusset set



Roll Bar/Cage Mounting Plate

1/8" thick steel mounting plates for Roll Bar or Roll Cage 6" x 6" square.

Sold ea. (Same part as shipped with RB & RC's)

P/N

- 13-353 Roll Bar & Cage Mount Plate 6" x 6" x 1/8" thick

Window Nets sfi 27.1

S&W window nets have 1" wide webbing with loops at the top and bottom to accommodate mounting rods. The S & W window net mounting kit features a quick release latch that is easily operated even with the driver belted into the seat. The kit is designed to allow the net to drop out of the way to allow easy entrance and exit from the race car. All necessary hardware is included.



Click to View the Demo Video

P/N

- 75-350 24" x 24" Black window net
- 75-354 24" x 24" Red window net
- 75-356 24" x 24" Blue window net
- 75-361 18" x 24" Black window net
- 75-387 Quick Release Window Net Mount Kit
- 75-387R Quick Release Upgrade Kit

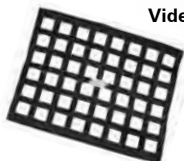

Video Camera Mount

S&W Race Cars camera / camcorder mount is perfect for the doorslammer racer who wants to mount a camera or camcorder in their race car. Available for either 1-5/8" roll cages or 1-3/4" roll bars, the mount fastens securely with the two hose clamps provided. Included is a 1/4-20" thumb screw to secure the camera to the mount. Tumbled Finish.

P/N

- 13-406 1-5/8" Camera mount
- 13-407 1-3/4" Camera mount



Helmet Hooks

This trick, little aluminum hook is available for any 1-5/8" or 1-3/4" roll bar or cage. Keeps helmet secure while trailering or driving the car around the pits. Avoid damaging helmet or components in the interior of your race car by "hanging" your helmet. Tumbled Finish.

P/N

- 13-401 1-5/8" Helmet hook
- 13-402 1-3/4" Helmet hook
- 13-408 Switch Box Roll Cage Mount w/integral Helmet Hook (fits 1-5/8" tube)



Steering Wheel Hook

Adjustable Steering Wheel Hook - Tumbled Finish

P/N

- 13-409 Fits 1-5/8 Tube
- 13-411 Fits 1-3/4 Tube



Custom Window Nets & Door Nets

Custom Window Nets Feature: 1" Nylon Webbing with a Box stitch pattern for strength & durability - 2" Box - Individual Loop Mount - Sfi 27.1 Rating - Colors: Black, Red, Blue, Purple, Pink, Green & Brown. Sold ea. - Up to 4 sq. ft. -

****Must Complete Diagram with Measurements** Form is Avail. on the Product Instructions Page of our WebSite www.swracecars.com**

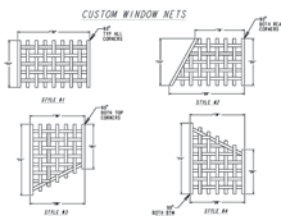

P/N

- 75-371 Custom Size Window Net
- 75-378 Custom Size Door Net (up to 12 sq. ft.)

Roll Bar & Roll Cage Padding

P/N

- 13-403 Black - 3' - offset (Non Sfi)

Roll Bar & Roll Cage Padding sfi

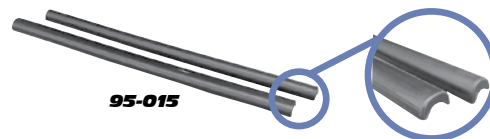

P/N

- 95-012 Roll bar pads - JAZ, 3' length SFI strip type fits 1-5/8" roll cage tubes
- 95-015 Roll bar pads - JAZ, 3' length SFI strip type fits 1" helmet tubes

WHEELIE BAR WHEELS

Replacement Wheelie Bar Wheels

Standard on all S&W wheelie bars, our new bearing type wheel offers free rotation even under extreme loading. Sold each

<u>P/N</u>	
40-315	1/2" hole wheel
40-353	3/8" hole wheel



WHEELIEZ LITE Wheelie Bar Wheels

Wheeletz LITE are thinner to reduce weight & may be used on most applications up to Pro Stock and Top Sportsman

<u>P/N</u>	
40-354	3/8" hole Wheeletz wheel - pair
40-352	1/2" hole Wheeletz wheel - pair

**35%
Less Weight**



WHEELIEZ Wheelie Bar Wheels

Wheeletz are drag race specific wheelie bar wheels made of 7,000 psi polymer that is designed for high rotational load and wear application. They won't push, dig or skid.

<u>P/N</u>	
40-350-1	3/8" hole Wheeletz wheel - single
40-351-1	1/2" hole Wheeletz wheel - single
40-350	3/8" hole Wheeletz wheel - pair
40-351	1/2" hole Wheeletz wheel - pair

BILLET Wheelie Bar Wheels

Hole, Star & Spoke Styles with 3/8" Hole. Sold Each.

<u>P/N</u>	
40-9001	Hole w/o Bearing
40-9006	Hole w/Bearing
40-9000	Star w/o Bearing
40-9005	Star w/Bearing
40-9002	Spoke w/o Bearing
40-9007	Spoke w/Bearing



ROUND TUBING - 2X3 TUBING - FLAT STOCK

2"x3" Rectangular Tubing | Round Tubing | Flat Stock

If you have ever had to repair or update your race car, you know what an expense and hassle it can be trying to get a short length of tubing from the local steel supplier. S&W Race Cars can ship you tubing in up to eight foot lengths by FEDEX. The tubing listed here is the same, high quality tubing used in all S&W Race Cars and Components. 8ft length MAX shipping length.

Sold by the foot - Call for pricing - All Tubing Sales are Final

2X3 Rectangular Mild Steel Tube

<u>P/N (EWS)</u>	
2X3X083RC	2X3 x .083" wall w/rounded corners
2X3X120RC	2X3 x .120" wall w/rounded corners

Round Tube EWS | DOM | CM

<u>P/N (EWS)</u>	
1625X134EWS	1-5/8" x .134" wall
1750X134EWS	1-3/4" x .134" wall

<u>P/N (DOM)</u>		<u>P/N (Chrome Moly)</u>	
750X083DOM	3/4" x .083" wall	250X058CM	1/4" x .058" wall
1X095DOM	1" x .095" wall	375X058CM	3/8" x .058" wall
1X120DOM	1" x .120" wall	500X058CM	1/2" x .058" wall
1X156DOM	1" x .156" wall	625X058CM	5/8" x .058" wall
1250X120DOM	1-1/4" x .120" wall	750X058CM	3/4" x .058" wall
1500X095DOM	1-1/2" x .095" wall	750X120CM	3/4" x .120" wall
1500X120DOM	1-1/2" x .120" wall	875X058CM	7/8" x .058" wall
1750X120DOM	1-3/4" x .120" wall	875X065CM	7/8" x .065" wall
1875X120DOM	1-7/8" x .120" wall	875X083CM	7/8" x .083" wall
3X083TDS	3" x .083" wall	875X120CM	7/8" x .120" wall
3X188DOM	3" x .188" wall	1X058CM	1" x .058" wall
		1X095CM	1" x .095" wall
		1X120CM	1" x .120" wall

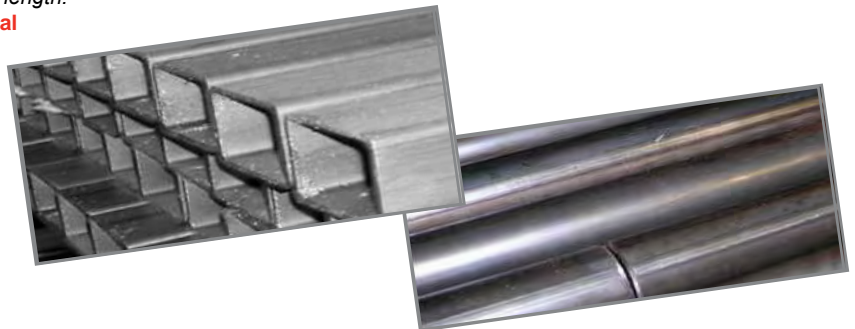

**Blueprints are
FREE
with Chassis Kit
Purchase!
Pg.86**



Measuring WB Length?

TECH TIP

Wheelie Bars Measure from Centerline of Rear Axle to the Center of the Wheelie Bar Wheel bolt.



All S&W Wheelie Bars are \$ ITEMS

Properly designed and installed wheelie bars help control E.T. robbing wheelstands without affecting load transfer. Different types of race cars require different types of wheelie bars. Your basic bracket race doorslammer doesn't need 100" solid mounted wheelie bars but an Alcohol Funny Car would have a big problem without them. For doorslammers, S&W offers two styles of wheelie bars. The traditional wheelie bar is 48 inches long from the rear axle centerline and utilizes a flat aluminum bottom leaf. These bars are available in chrome or zinc plated, and come with all necessary mounting hardware. S&W Race Cars new, all tubular doorslammer wheelie bar measures 54 & 60 inches long and is available unpainted. Both styles are spring loaded and easily adjustable. S & W Race Cars single wheel wheelie bar was designed specifically for the new Aero Roadster but can be easily adapted to most altered, dragsters or street roadsters. Available chrome plated or unpainted, the S & W single wheel wheelie bar is 70" long and measures 14-1/2" wide at the upper mounting tabs. Also available is a 100" wheelie bar kit, identical to the wheelie bars used on all S & W top alcohol funny cars. This wheelie bar kit is available in single or dual wheel versions. Replacement parts are available for all wheelie bars.



40-304

P/N

40-304
40-306

• **48" Wheelie Bars**

Wheelie bars 48" spring loaded leaf
Wheelie bar 48" single wheel, all tubular for use with Strange aluminum dragster housing
Wheelie bars 48" spring loaded leaf for use with rear housing with 2" x 3" back brace

40-331

• **Up to 60" Spring Loaded Wheelie Bars**

40-337

Wheelie bar kit, unwelded, spring loaded, all moly tube makes wheelie bar up to 60" max length x 26" max width

40-339

Wheelie bar kit, unwelded, spring loaded, all moly tube for use with 2x3 brace makes wheelie bar up to 60" max length x 26" max width

• **68" Wheelie Bars for P5 Housing Brackets**

40-344

68" Tubular wheelie bar with unwelded "K" member for 3" Tube

40-345

68" Tubular wheelie bar with unwelded "K" member for Back Brace

• **70" Wheelie Bars**

40-308U

Single wheel wheelie bar (unwelded)

• **80" Wheelie Bars - Adjustable Slip Tube Design**

40-347U

Unwelded Hi-Po Wheelie Bar. Purpose built for powerful and demanding drag race cars. The slip-tube construction bar features a floating "X-Member" on the lower struts. Maximum length is 80" and Maximum width is 28"

• **Up to 85" Wheelie Bars**

40-384U

Wheelie bar kit, unwelded, up to 85" Long measured from axle center line to wheelie wheel center line. 1-1/4 X 065 chrome moly upper & lower strut tubes, 1-1/8 X 058 chrome moly crossmember & X-member tubes up to 28" wide. Wheel brackets are welded, all other tubes to be cut and fit by customer, top tube has right & left hand 1/2 chrome moly FK Rod Ends for quick adjustments. Includes double shear Housing brackets, customer to trim housing tabs to fit rear housing

40-306

Fully welded 48" single wheel wheelie bar for dragsters using a Strange aluminum housing. Includes a Wheeliez wheelie bar wheel.



40-347 Detail

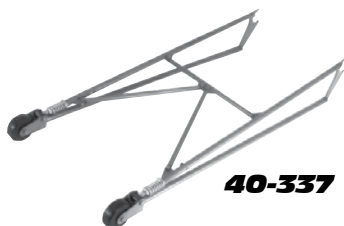

40-337



40-384U



Spring Loaded Wheelie Bar Detail

40-310
40-311

• **100" Wheelie Bars**

100" Wheelie bar kit • funny car • dual wheel
100" Wheelie bar kit • funny car • single wheel

40-307
40-319
40-3126
66-021

• **Pins & Replacement Parts**

Replacement aluminum leaf
Replacement pin for 40-304
Replacement pin for 40-337 & 40-339
Replacement pin for 40-384U

Door Car Tow Hook Kit

- Tube and gussets weld to roll cage.
- Clear zinc plated
- Works with "hoop" or "runner" style cage
- 5/8" diameter chrome moly pin

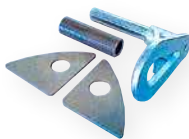

Roll Cage Mount

P/N
75-810 Tow hook kit - door car

Body Front End Mounting Kit

95-500 For use with one piece fiberglass front ends. S&W front end mounting kits can be used on O.E.M. frames or an all-tube chassis. Slip joints provide easy installation and removal plus maximum strength under aerodynamic load. This S&W kit includes six (6) body mounting pads, two (2) frame mounting tubes, 7-1/2 feet of 7/8" tubing, 6 feet of 3/4" tubing, two (2) quick pins and six (6) quarter-turn fastener tabs with buttons, springs & rivets.

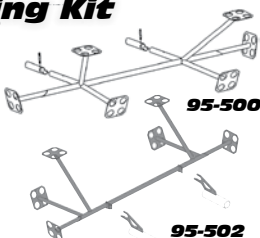

95-500

95-502

P/N
95-500 Body Front End mount kit (Slip Tube Type)
95-502 Body Front End mount kit (Guide Plate Type)

Door Window Frame Mount Kit

Lexan door windows require additional support to keep them properly attached to the doors. S&W's door window support kit gives you everything needed to fabricate window supports for your car. S&W's door window frame kit works with both steel & fiberglass doors and includes;

- (2) 7 Ft. lengths & (2) 4 Ft. lengths of 3/8" x .058" wall DOM tubing
- (32) window mounting tabs
- (32) 6-32 stainless countersunk screws & nylock nuts
- Frame mounting tabs
- Stainless frame mounting hardware
- Bending fixture



P/N
95-654 Door window frame kit

Upper Window Latch Kit

S & W's upper window latch kit is designed to keep airflow from pulling the top of the door window away from the body at high speeds. Kit does one door and includes all necessary hardware

P/N
95-314 Upper window latch kit
95-314P Upper window latch kit - pair



Door Hinge Kit

For use when mounting fiberglass doors to a tube chassis. This S & W door hinge kit allows easy removal of the doors. Kit includes; four (4) mounting tubes, two (2) aluminum door hinge brackets and all necessary hardware.

P/N
95-550 Door hinge kit - for 2 doors



Inside Door Handle Kit

Designed for use on fiberglass doors with aluminum panels. Each kit includes hardware for two doors - two (2) aluminum release handles, two (2) mounting brackets, two (2) 1/4" x 2' long threaded tubes, four (4) spherical rod ends and all hardware.

P/N
95-552 Inner Door Handle Kit

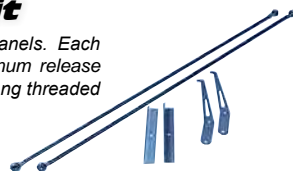

Windshield/Rear Window Mounting Kit

Kit includes 15' of rubber stripping, 50 stainless steel screws & nylock nuts and 1 tube of sealant. Available in 1/2" and 3/4" wide sizes. Rubber strip is 3/8" thick.

P/N
95-657 3/4" Wide windshield mount kit



Lexan Windshield Support Kit

S&W's new windshield support kit is designed to keep the center of your lexan windshield from pushing in at speed. Unique adjustable "feet" allow use on any dash or windshield frame. Kit includes two aluminum supports, two base "feet" and all necessary hardware. **Note: NOT for use on windshields that are excessively curved from top to bottom.**

P/N
95-684 Windshield Brace Mount Kit (for 26" - 36")



Aluminum Door Pull Kit with or without Strap Kit

- 109 kits included (2) aluminum door pulls and hardware
- 110 kits included (2) aluminum door pulls (2) door limiter straps and hardware

P/N
95-109 Door pull kit
95-109C Door pull kit - Bowtie
95-109F Door pull kit - Script "F"
95-109M Door pull kit - Pentastar
95-109SW Door pull kit - S&W logo
95-129 Door pull & strap kit
95-129C Door pull & strap kit - Bowtie
95-129F Door pull & strap kit - Script "F"
95-129M Door pull & strap kit - Pentastar
95-129SW Door pull & strap kit - S&W logo



5 Designs!



ALUMINUM SPOILER KITS

Universal Spoiler Kit

Designed fit almost any type car & easy installation. The universal spoiler kit includes all necessary hardware, easy to trim side plates and a 52" x 12" spoiler deck. **95-702**

P/N
95-700 Universal rear spoiler kit
95-702 Spoiler support rod (sold each)



68-72 Chevelle Spoiler Kits

P/N
95-715 68-72 Chevelle, GTO, Cutlax, Skylark, Monte Carlo



70-92 Camaro Spoiler Kits

Bolt on, adjustable competition spoiler features chrome moly deck support frame and support struts. Deck plate extends 14" from the edge of the trunk lid on 70-81 Camaro

P/N
95-707 70-81 Camaro rear spoiler kit
95-712 82-92 Camaro rear spoiler kit



94-02 S-10 Pick Up Spoiler Kit

S&W's new S-10 aluminum spoiler kit comes with all necessary mounting hardware and two spoiler support strut rods. Spoiler is 54" wide and extends 14" off the back of the truck.

P/N
95-705 94-02 S-10 Pick Up
95-708 82-93 S-10 Pick Up



79-93 Mustang Spoiler Kit

1979 -93 Mustang aluminum spoiler kits come with all necessary mounting hardware and two spoiler support strut rods. It is 54" wide and extends 14" off the back of the car.

1979-93 available in Carbon Fiber too!!

P/N
95-703 79-93 Mustang Hatchback
95-704 79-93 Mustang Coupe
95-706 79-93 Mustang Hatchback - Carbon Fiber



95-706

2005-2009 Mustang Adjustable Rear Spoiler Kit

Bolt on, adjustable competition spoiler features chrome moly deck support frame and support struts. Deck plate extends 14" from the edge of the trunk lid.

P/N
95-709 05-09 Mustang



Corvette Roadster Adjustable Rear Spoiler

Bolt on, competition spoiler and support struts. Deck plate extends 14" from the edge of the trunk lid. Spoiler fits Suncoast 2K Corvette roadster body

P/N
95-710 2K Corvette Roadster



STRUT FRONT SUSPENSION PACKAGES

2"x 3" Strut Front Frame & Suspension Packages

S&W's strut front frame package is designed to simplify installation for the do-it-yourselfer. The base frame package features mandrel formed 2" x 3" frame rails, rear lower control arm mounts, a fully welded rack & pinion crossmember with front lower control arm mounts and a front subframe support package to tie the frame rails to the roll cage. Complete installation requires the use of an upper strut mounting kit. This kit can be used with any eye or stud mount Strange strut package.



- P/N
- 36-500 Strut front frame rails, crossmember & supports
 - 35-376 Strut upper mount kit (for eye mount struts)
 - 35-378 Strut upper mount kit (for stud mount struts)
 - 35-042 Flaming River Pinto rack & pinion
 - 36-006 Rack mount bushing & bracket
 - 36-007 Billet Rack mount clamp

"Round Tube" Strut Front Frame

S&W's round tube strut front frame is designed to simplify installation for the do-it-yourselfer. This frame package features 1-5/8" frame rails, front sub frame supports, pre notched "k type" crossmember, rack & pinion mount brackets, lower control arm mounts and upper strut mounts. Kits available for any Strange strut package shown on this page.



Struts not included Sold Separately

- P/N
- 36-501E Strut front frame rails - Mild steel for eye mount struts
 - 36-501S Strut front frame rails - Mild steel for stud mount struts
 - 36-502S Strut front frame rails - Chrome moly steel for stud mount struts
 - 36-502E Strut front frame rails - Chrome moly steel for eye mount struts

STRUTS

The ultimate suspension for any full bodied race car is the Strange front strut. All Strange struts feature fully adjustable KONI cartridges with a large 7/8" shaft and the same SPA-1 valving found on all KONI drag racing shocks. Struts are sold in sets with complete brake kit, springs, and a tubular lower control arm kit.

Strut Systems are priced complete with springs, wheel bearings, seals, hubs, studs, billet aluminum calipers, forged 1 piece slotted rotors, brake pads, mounting brackets, steering arms, forged control arm outer end assemblies, lower control arm kit, Torrington thrust bearings, all hardware and instructions.



Mini Struts Are Available!

STRANGE Mini Strut- Altered Ultra Strut (Shown Above) P/N PSS280



STRANGE Strut (Shown Right) features Stud top mount & medium brake kit



- P/N
- PSS100 3" stroke, eye mount, internal adjustable, direct mount brakes
 - PSS105 3" stroke, stud mount, external adjustable, direct mount brakes
 - PSS105DBL 3" stroke, stud mount, external double adjustable, direct mount brakes
 - PSS110 3" stroke, eye mount, internal adjustable, medium duty brakes
 - PSS115 3" stroke, stud mount, external adjustable, medium duty brakes
 - PSS115DBL 3" stroke, stud mount, external double adjustable, medium duty brakes
 - PSS120 3" stroke, eye mount, internal adjustable, heavy duty brakes
 - PSS125 3" stroke, stud mount, external adjustable, heavy duty brakes
 - PSS125DBL 3" stroke, stud mount, external double adjustable, heavy duty brakes
 - PSS200 Ultra Strut, stud mount, single ext. adjustable, lightweight brakes
 - PSS205 Ultra Strut, stud mount, double ext. adjustable, lightweight brakes
 - S3750LH Knuckle (Left)
 - S3750RH Knuckle (Right)

Your Choice of STRANGE Stud or Eye Mount, Internal or External adjustment, Spring Rate & Brake Kit! Direct Mount Brakes Do Not Require Hubs & Related Components.

Weld-On Tie Rod End Kit

for use with Pinto rack and struts

Features 1/2" or 7/16" rod ends that bolt directly to Strange Engineering steering arms Sold in pairs



- P/N
- 35-005 Sleeve type Pinto tie rod kit. Strut or A-arm with 1/2" Rod Ends
 - 35-105 Weld On, Pinto tie rod kit for Struts with 7/16" Rod Ends
 - 35-004 Dragster tie rod end kit with 3/8" Rod Ends

Upper Strut Mounts

Custom formed, waterjet cut brackets allow for easy installation of Strange Engineering and other popular struts with eye mount or stud type upper mounts. Stud type are formed in left & right hand sets, these mounts are available in either mild steel or chrome moly versions. Sold in pairs



- P/N
- 35-376 Strut upper mount kit (for eye mount struts)
 - 35-378 Upper strut mounts 3/16" mild steel- stud mount
 - 35-378CM Upper strut mounts 3/16" chrome moly steel- stud mount
 - 60-501 Lower strut A-Arm Tabs mild steel
 - 60-502 Lower strut A-Arm Tabs chrome moly

QA-1 PROACTIVE FRONT SUSPENSION SYSTEM

The QA1 Pro-Active System is the most advanced and complete bolt-on front suspension ever engineered for many racing applications (not suitable for street use due to lightweight components). The Pro-Active System has it all - quality, performance and adjustability. Whether you are a weekend racer or Pro driver, the QA1 Pro-Active System does it all.

- Tubular K-member
- Rod End or Bushing Mounted Tubular Control Arms
- Coil-Over Conversion Kit
- Struts with Springs
- Caster/Chamber Plates



Call for details and current pricing on your specific application.



TECH TIP

Struts or A-Arms?

When choosing a front suspension package for your race car, keep these things in mind. Coil over shock - tubular a-arm suspensions are generally more versatile, due to their longer suspension travel. Longer suspension travel will allow you more range of tuning adjustments for better traction on slippery tracks. On the other hand, strut front ends take up less engine compartment space. This is of major importance in large engine / small car applications where header and steering column space is at a minimum. Although a strut front suspension is a little lighter, both a strut front or a tubular a-arm front frame & suspension system will take a substantial amount of weight off the front

Extreme Duty Front A-Arm Frame & Suspension Package - Mustang II Type

S&W Race Cars all new, extreme-duty, a-arm front frame & suspension package is specifically designed to withstand the loads applied by both heavy weight E.T. race cars and even the heaviest Pro/Streeter. This frame features 2" x 3" mandrel formed frame rails made from heavy duty .120" wall tubing. All brackets are precision, waterjet cut from 3/16" steel. Also included in each package is a floor x-brace kit for added support. More support comes from a pair of front subframe supports, to tie into your roll cage and a pair of shock support tubes (not shown in photo). This frame package uses Mustang II spindles (S&W fabricated spindles are available at extra cost), Mustang II rack & pinion and either QA1 or Strange coil over shocks. Tubular a-arm packages are powder-coated for a durable and attractive finish. In addition to the weight savings, you get the benefits of a fully adjustable, "zero-bump-steer" front suspension with coil over shocks for the ultimate in adjustability and consistency. The rack and pinion steering eliminates the sloppy original steering box and offers added header clearance by moving all the steering components forward of the motor. Part number 36-400, frame rail and crossmember package, features all brackets completely fixture welded to the frame rails, insuring proper alignment of all critical suspension mounts. The rack & pinion crossmember is cut to width and the floor support tubes are notched and cut for easy installation. Shipping these components separately makes the entire package ship standard (non-truck freight,) the most cost effective shipping option. Available in three "hub to hub" widths 52-3/16" (24" outside to outside frame width), 55-3/16" (27" outside to outside frame width) and 58-3/16" (30" outside to outside frame width) Please specify when ordering.



58-3/16" Wide Kit P/N 36-400

- 36-400 A-Arm frame rails & crossmembers & x-brace
- 36-401 Tubular upper a-arm package
- 36-402 Tubular lower a-arm package
- 36-009 Screw-in ball joint (each- 2 required - fits either a-arm)
- 36-009L Screw-in ball joint (each- 2 required - fits either a-arm)
- 36-405 Mustang II tie rod end (pair)
- 36-406 Rack mount bushing
- 36-511 Mustang II steel spindles (pair)
- 13-350 Front sub-fame supports (ties frame to roll cage)
- 35-037 Flaming River, Mustang II rack & pinion
- 50-052 Strange adj. alum.front coil-overs (pair)
- 50-0** 2-1/2" x 7" front coil spring (pair)

**Part number of spring will vary by application

P/N

36-402B Replacement lower a-arm bushing



35-511

Note:

Spindle Nuts
Not Included.

P/N 65-615H
Spindle Nut
& Hardware Kit



36-511

52-3/16" Wide Kit P/N 36-400-6

55-3/16" Wide Kit P/N 36-400-3

- 36-400-3 A-Arm frame rails & crossmembers & x-brace
- 36-401 Tubular upper a-arm package
- 36-402 Tubular lower a-arm package
- 36-009 Screw-in ball joint (each- 2 required - fits either a-arm)
- 36-009L Screw-in ball joint (each- 2 required - fits either a-arm)
- 36-405 Mustang II tie rod end (pair)
- 36-406 Rack mount bushing
- 36-511 Mustang II steel spindles (pair)
- 13-350 Front sub-fame supports (ties frame to roll cage)
- 35-037-3 Flaming River, Mustang II rack & pinion
- 50-052 Strange adj. alum.front coil-overs (pair)
- 50-0** 2-1/2" x 7" front coil spring (pair)

**Part number of spring will vary by application

P/N

36-402B Replacement lower a-arm bushing

Torsion Bar Assembly

S&W torsion bars are designed to provide limited front end travel for dragsters and alters. Splined ends allow for adjusting pre-load and ride height. The steel housing tube is strong enough to be used as a structural part of the chassis. Torsion assemblies are available for altered & roadsters which feature a 26" width and comes with two 5" arms or for dragsters which is 20" wide and utilize 6-3/8" arms.

P/N

- 35-015 Front torsion assembly (altered/roadster)
- 35-016 Front torsion assembly (dragster)



35-015



Front Suspension Limiters

Designed for use on vehicles with stock A-arm or strut style front suspensions, these limiters control front suspension travel during acceleration and control weight transfer to the rear wheels. Easily installed and fully adjustable.

P/N

- 35-380 Rubber snubber type for A-arms
- 35-381 Cable type for struts



35-380

35-381

BOLT-IN FRONT K-MEMBERS & COMPONENTS

Street Kits & Race Kits available for many Cars & Trucks

S-10 TUBULAR A-ARM KITS // 1964-1970 Mustang // 1962-1967 Chevy II / Nova // 1982-2002 Camaro/Firebird
Mopar B&E Body // Mopar A-Body

Other Kits Available. If you don't see what you need, Please Call Us! 1-800-523-3353

QA1



1962-1967 CHEVY II BOLT-ON ROUND TUBE STRUT FRONT FRAME



- | | |
|--------------------------|-------------------|
| Front Subframe | (62-67) 35-CN6267 |
| A-Arms Bushing Style | (62-67) 35-CN5000 |
| A-Arms ADJ Rod End Style | (62-67) 35-CN5010 |
| Strut with No Brakes | (62-67) 35-CN6200 |
| Pinto Steering Rack Kit | (62-67) 35-CN1500 |
| Hood Hinge Brackets | (62-65) 35-CN1050 |
| Hood Hinge Brackets | (66-67) 35-CN1000 |
| Radiator Core Support | (66-67) 35-CN2050 |
| Fender Support | (66-67) 35CN3050 |

Chrome Moly frame additional fee.

Photos Shown
with
OPTIONAL
Inner
Fender
Kit

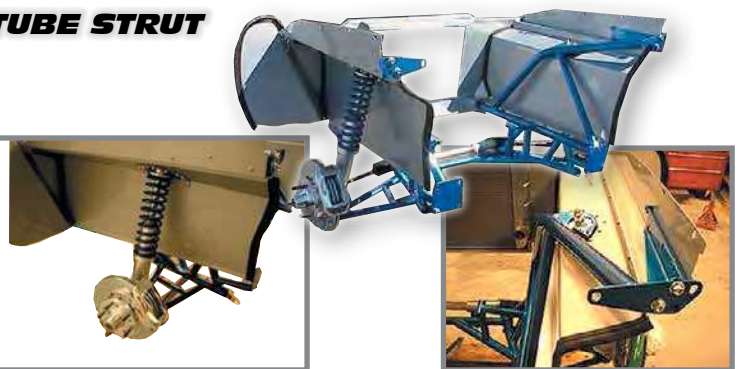

DIRECT-FIT BOLT-IN FRONT FRAME & SUSPENSION PACKAGE

1967-1969 CAMARO • 1968-1974 NOVA



Danny Slusher

S&W Race Cars all new, bolt-in front end kit, extreme-duty, a-arm front frame & suspension package is specifically designed to withstand the loads applied by both heavy weight E.T. race cars and even the heaviest Pro/Streeter. This frame features 2" x 3" mandrel formed frame rails made from heavy duty .120" wall tubing. VIEW FULL DETAILS at www.swracecars.com P/N 36-420



Engine & Transmission
are Not Included.



social @SWRACECARS

website SWRACECARS.COM

Direct Fit Rack & Pinion Steering Conversion Kits

- P/N**
 35-045 S-10 Pick Up R&P Kit
 35-046 1970-1981 Camaro/F-Bird R&P Kit
 35-3173 1964-1967 Chevelle
 35-3193 Malibu G-Body Kit
 35-3173-2 1968-1972 Chevelle Kit



Saves 35 lbs.!
 Welding Required

Dragster - Altered Spindles

S&W Race Cars stocks the same spindle used on all S&W dragsters & altered. All spindles have align honed bronze bushings, are finish ground and heat treated for maximum durability. Strange & Stiletto (anglia type) spindles are drilled for top or bottom steering arm attachment. The new Strange spindle set features an all new greaseable king pin utilizing two grease passages to keep your steering operating smoothly at all times!

35-080

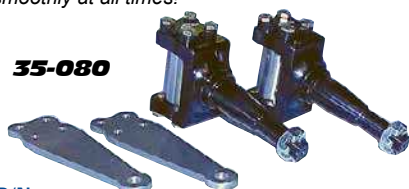

35-014 & 35-013

- P/N**
 35-003 Dragster Bolt On Front A-Arm Kit - Short King Pin Boss
 35-003L Dragster Bolt On Front A-Arm Kit - Long King Pin Boss
 35-084 Custom King Pins - Call for Details
 35-013 King pin boss (each, fits P&S, M.W., and SPE)
 35-014 King pin boss (each, fits 2")
 35-080 Stiletto 4130 spindle set - complete with 2-5" arms, king pins and hardware (anglia type)
 35-081 Strange 4130 spindle set - complete with 2-5" arms, king pins and hardware (anglia type)
 35-063 Spindle Nuts (pair)
 35-090 King Pin Spacer Bushing (ea.) 1.19" OD X 0.70" ID X 0.225" THICK

Mustang II Spindles

Because OEM spindles are almost impossible to find in the boneyards, S&W Race Cars offers a fabricated version. Available for the Mustang II front frame package shown on page 25 these spindles have an integral 4 piston brake bracket compatible with Wilwood and most other manufacturer's brake kits. New for the builder on a budget, brand new, forged steel Mustang II spindles at a new low price!!

36-511



Note:

Spindle Nuts Not Included

- P/N**
 36-511 Mustang II Forged Spindles - pair
 65-615H Spindle Nut with Hardware Kit

Rack & Pinion Conversion 67-69 Camaro - 68-74 Nova

S&W's new rack conversion kit is designed specifically for the 67-69 Camaro & 68-72 Nova. This kit replaces the original rear steer, steering box with a front mounted rack & pinion. Kit saves weight by removing the original lower control arm crossmember and replacing it with lightweight tubular crossmembers. As an added bonus the crossmember has been made removable for simplified oil pan access. Kit includes rack mounting brackets, tie rods, diagonal brackets, billet rack mounts & gussets. Also included are crossmember block off plates that include integral tie down loops. All necessary hardware is included. Kit removes approximately 25 pounds from the front of your car. Spindle steering arms and Pinto style rack & pinion not included - sold separately. Cutting, fitting and welding required for installation

- P/N**
 35-371 Rack Mount Kit..now includes 35-007
 36-006 Poly Rack Mounts
 36-007 Billet Rack Mounts
 35-042 Flaming River Pinto Rack & Pinion
 35-077 Steel steering arms - pair
 35-078 Aluminum steering arms - pair

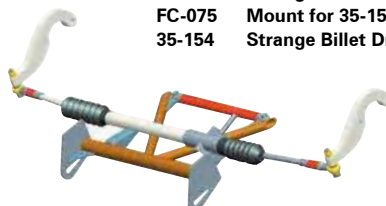

Dragster Rack & Pinions

Custom tie rod kits are available for all dragster rack and pinions. Tie rod kits include all tubing, threaded tube ends, spherical rod ends and all hardware for installation. Tie rod kits are shipped unassembled and require some welding.

Stiletto



- P/N**
 35-004 Dragster tie rod kit
 35-050 Stiletto Dragster rack & pinion (11" rod end centers)
 35-150 Stiletto Dragster wide rack & pinion (14-1/4")
 35-165 Split Coupler (5/8" x 36 spline)
 35-151 Split Coupler (9/16" x 26 spline)

Split Coupler

Pinto & Mustang II Rack & Pinions

S & W Race Cars stocks only new rack and pinion units. Used or rebuilt rack and pinions are unacceptable for high performance drag race or pro/street applications. Custom tie rod kits are available for Pinto style rack and pinions. Tie rod kits include all tubing, threaded tube ends, spherical rod ends and all hardware for installation. Tie rod kits are shipped unassembled and require some welding. Quality and safety should never be sacrificed, with this in mind S & W rack and pinions should be your first choice.

- P/N**
 35-005 Sleeve type Pinto tie rod kit. Strut or A-arm with 1/2" Rod Ends
 35-105 Weld On, Pinto tie rod kit for Struts with 7/16" Rod Ends
 35-036 Flaming River, 79-93 Mustang rack & pinion
 35-037 Flaming River, Mustang II rack & pinion
 35-047 Flaming River, Mustang II rack & pinion 6" narrow
 36-406 Mount Kit for P/N 35-037 rack & pinion
 35-037-3 Flaming River, Mustang II rack & pinion (3" narrow)
 35-044 Flaming River, Mustang II power rack & pinion
 35-042 Flaming River Pinto rack & pinion
 35-369 Flaming River Pinto rack & pinion mount - 4-3/8"
 35-370 Flaming River rack & pinion - 6-3/4"
 36-006 Rack mount bushing & bracket for 35-042 rack
 36-007 Billet rack mount clamp for 35-042 rack



Steering Boxes for Funny Cars and Altered

Designed for front motor applications, where the driver is located in the center of the car. The end of the steering shaft is splined for adjusting the pitman arm location. S & W offers these steering boxes in two different widths to fit your specific requirements. Funny car boxes measure 13" from the center of the steering column adaptor to the very end of the cross shaft. Altered boxes are 15". Replacement parts available.

FC-075



35-153



35-154

- P/N**
 35-153 Strange Billet Funny Car
 FC-075 Mount for 35-153 (mounts box below crossmember)
 35-154 Strange Billet Dragster/Altered/FED

35-078



STEERING COMPONENTS

Steering Wheel Disconnect

A simple push of a button allows quick removal of the steering wheel for easy entry and exit of the race car. A positive spring loaded locking device prevents accidental release. Steering shaft shank is steel with a 1" O.D. and 3/4" I.D. The aluminum hub is available undrilled or drilled with three (3) mounting holes on a 1.75 bolt circle. Also available is a disconnect specifically designed for the butterfly steering wheel found on most dragsters, altered or funny cars. This disconnect features a finely splined steel steering column shank with a 3/4" I.D. and an aluminum hub with a spring loaded locking ring.

- P/N**
 95-400 Steering wheel disconnect - drilled 3 hole
 95-402 MW Butterfly steering wheel disconnect - 4 hole
 95-403 MW Butterfly steering wheel disconnect - 3 hole
 95-404 Steering wheel disconnect - Grant G/T
 95-406 Steering wheel disconnect - Strange 3 & 4 hole
 95-407 Adapter (Grant GT wheel to 3 hole disconnect)

- P/N**
 95-412 PRO-WERKS Steering wheel disconnect - drilled 4 hole

Steering Column Kit

S&W Race Cars now offers three different steering column kits that are easy to install and constructed of all chrome-moly tubing for superior strength. Each kit features a chrome-moly outer tube with nylon bushings to resist binding, outer tube supports, chrome-moly inner shaft, high - strength 3/4" universal joint and a steering wheel quick-release hub. Now, these three kits offer the builder a choice of different adapters and universal joints for mating the column to the steering rack or box. Also available is a lightweight, steering column mount kit that features all chrome moly tubing and two split clamps which allow easy removal of the steering column.



- P/N**
 35-372 Steering column kit with standard Pinto/Mustang II sleeve
 Also fits Wilwood & Flaming River rack & pinions
 35-372GM Steering column kit with early GM splined u-joint
 35-372PM Steering column kit with Pinto manual splined u-joint
 35-372M Steering column mount kit
 35-390 Replacement bushing for steering column kits (ea.)
 35-398 Steering column support kit

2005 & Newer Mustang Bolt-In Steering Kit

- P/N**
 35-386 Replaces OEM Column
 Steering Wheel Mount is Optional

King Pin Bushing Removal & Installation Tool



S&W's new bushing removal and installation tool makes the job a snap! Works with all P&S or SPE Angita type spindles. Kit includes bushing tool & drive pin and can be purchased with or without the 11/16 diameter reamer required to properly resize the bushings after installation. Replacement king pins and bushing sold separately.

Ask Us About Custom King Pins & Bushings!
 Made to Your Specifications

- P/N**
 35-099 King pin bushing tool
 35-099R King pin bushing tool with reamer
- King Pins**
 35-083 SPE (each)
 35-084 Kingpin to Customer Specs
 35-100 P&S 3.192" long w/2 flats & shoulder (each)
 35-103 P&S 2.625" long no shoulder or flats (each)
 35-159 Stiletto 3.000" long (each)

- Bushings**
 35-082 SPE (each)
 35-090 King Pin Spacer Bushing (each)
 35-101 P&S .610" long w/shoulder (each)
 35-102 P&S .375" long no shoulder (each)
 35-156 Stiletto fits 3" long king pin (each)



- P/N**
 35-226 Set Orange Plastic Grips
 35-220 Set Gray Plastic Grips
 35-223 Set Red Plastic Grips
 35-221 Set Blue Plastic Grips
 35-224 Set Black Plastic Grips



Steering U-Joints & Splined Adapters

Special order available for almost any application. Ask Us About it!

- P/N**
 35-067 3/4" I.D. x 3/4" I.D. (drag race version)
 35-067N 3/4" I.D. x 3/4" I.D. (needle bearing type - for street use)
 35-375 for Pinto manual rack spline (.562-26) x 3/4" I.D. (race)
 35-378F Pinto splined adapter - female - fits 3/4" tubing (manual rack only)
 35-383 for 75 & earlier GM manual spline (.728-30) x 3/4" I.D. (race)
 35-383N for 75 & earlier GM manual spline (.728-30) x 3/4" I.D. (street)
 35-384 for early Camaro & Pinto power rack spline (.735-36) x 3/4" I.D. (race)
 35-366 for early Camaro & Pinto power rack spline (.735-36) x 3/4" I.D. (street)
 35-395 S10 Intermediate Steering shaft kit
 35-396 (.562-36) x 3/4" I.D. (race)
 35-397 (.687-36) x 3/4" I.D. (race)

Replaces both factory "rag" joints with high performance universal joints and replaces stock intermediate shaft with small diameter splined shaft. Provides extra clearance around headers.



Door Car/Super Gas Wheel

Black vinyl wrapped, 13" diameter steering wheel with black anodized center is perfect for full bodied door cars.

- P/N**
 35-773 Door Car Steering Wheel



Dragster, Altered & Funny Car Steering Wheels & Accessories

- P/N**
 35-256 Butterfly Wheel w/Orange Plastic Grips
 35-251 Butterfly Wheel w/Gray Plastic Grips
 35-254 Butterfly Wheel w/Red Plastic Grips
 35-253 Butterfly Wheel w/Blue Plastic Grips
 35-255 Butterfly Wheel w/Black Plastic Grips
 CALL Custom Colored Plastic Butterfly Wheel Grips
 35-250 Bare Butterfly Steering Wheel Tumbled finish. Grips not included.
 35-056 Dragster wheel (1" depth)
 35-6134 "D" shaped steering wheel - black spokes
 85-008 Button mount for D type wheel 3 button
 85-012 Button mount for D type wheel 4 button
 85-003 Button mount for butterfly steering wheels
 85-005 Button mount with cover for butterfly wheels
 85-114 Button mount TOP w/Sides for butterfly wheels

Replacement Grips Shown at Bottom of Page



Adjustable Torque Arm

S&W Race Cars 82-02 Camaro / Firebird torque arm is designed to the same specifications as our own "race bred" ladder bars. Made of high quality, 1" x .156" wall DOM steel tubing, each torque arm is "direct threaded" for maximum strength. Also utilized at the rear of the torque arm are the same "race proven" rod ends and adjusters featured on S&W's ladder bars. Up front each torque arm features an Energy Suspension polyurethane bushing for quieter ride and limited driveline vibrations while insuring high strength and long life. S&W Race Cars new 82-02 Camaro / Firebird torque arm must be used with an S&W Race Cars, 82-92 Camaro / Firebird subframe connector & crossmember kit, sold separately. S&W now includes proper length housing mount hardware with every torque arm. This has made it necessary to offer two variations of the kit. A "thru bolt" version is for vehicles using the stock GM housing or any after market housing where the torque arm attaches with two (2) long bolts that pass thru the housing. The second is a "four bolt" version for aftermarket housings that feature threaded holes in the housing and attach the torque arm with four (4) separate bolts. All components are powder coated for a long lasting, durable and attractive finish.



Lower Control Arms

Designed to withstand the rigors of weekly bracket racing, without sacrificing ride quality, S&W Race Cars new 82-02 Camaro / Firebird lower control arms are custom fabricated from super strong, 1-1/2" x .120" wall DOM steel tubing. High quality, Energy Suspension polyurethane bushings are installed in both ends to retain ride quality and eliminate bushing movement. These arms are a direct replacement for the factory control arm and install using the O.E.M. hardware. Powder coated for a long lasting, durable and attractive finish.



Kaitlyn Krause

Subframe Connectors & Crossmember Kit

Designed to be 100% bolt on for your 82-02 Camaro / Firebird, this kit requires no welding and can be installed using hand tools. This kit also clears all stock exhaust components while closely following the floor pan contour assuring you a close fit and maximum ground clearance. This is the only kit on the market which ties the subframes, rockers and floor pan into one assembly! The included crossmember features a mount for S&W's adjustable torque arm which can be purchased separately and installed along with the subframe connectors and crossmember, or you can retain your O.E.M. torque arm and mount. The connectors and crossmember are fabricated from 1-1/2" x .120" wall steel tubing and feature waterjet cut brackets for exact fit. These components are hand assembled on a custom welding fixture and MIG welded for high strength and ease of installation. **Ask About Finish Options**



Adjustable Panhard Bar

The S&W Race Cars 82-02 Camaro / Firebird panhard bar is also fabricated from high quality, 1" x .156" wall DOM steel tubing and features Energy Suspension polyurethane bushings at both ends. Our unique, left/right adjuster allows quick adjustments without removal of the mounting hardware. Powder coated for a long lasting, durable and attractive finish.



SAVE 11 POUNDS with Chrome Moly!

P/N

- 40-600** Conn. & Crossmemb. Kit - 82-92 Camaro or Firebird
- 40-600CM** Conn. & Crossmemb. Kit - 82-92 - chrome moly
- 40-610** Conn. & Crossmemb. Kit - 93-03 Camaro or Firebird
- 40-610CM** Conn. & Crossmemb. Kit - 93-03 - chrome moly
- 40-601** Adj. Torque Arm - thru bolt housings - 82-04
- 40-601CM** Adj. Torque Arm - chrome moly - thru bolt hous. - 82-04
- 40-601M9** Adj. Torque Arm - 82-04 - Moser 9" Rear
- 40-602** Lower Control Arms - Pair
- 40-602CM** Lower Control Arms - Pair - chrome moly
- 40-603** Adj. Panhard Bar
- 40-603CM** Adj. Panhard Bar - chrome moly
- 40-604** Weld in Crossmemb. Kit (for 82-92 w/existing connectors)
- 40-606** Adj. Torque Arm - four (4) bolt housings
- 40-606CM** Adj. Torque Arm - chrome moly - four (4) bolt housings
- 40-607** Panhard Bar Brace
- 40-607CM** Panhard Bar Brace - chrome moly
- 40-611** Weld in Crossmemb. Kit (for 93-03 w/existing connectors)



All S&W 1982-2002 Camaro/Firebird Bolt-Ons on This Page are \$ ITEMS



1982 - 2002 CAMARO & FIREBIRD BOLT-ON'S

Bolt In 9" Ford Housing & Adjustable Torque Arm System For 3rd & 4th Gen. Camaro or Firebird



40-449
(shown)

ASK About
Gen. 5 & COPO
BOLT-ON'S



Don Belles

S&W Race Cars new 82-02 Camaro / Firebird bolt in 9" Ford housing and torque arm combo offers the ultimate in performance and durability for "stock" suspension race cars. S&W's unique torque arm to housing bracket clears all Stock, Strange & Mark Williams centers.

Several purchase options are available - The rear and torque arm mount are available separately for cars already equipped with an S&W torque arm. A package is available for those of you who already are using a 9" Ford but want to install an S&W torque arm or a complete package is available with the torque arm, mount and rear housing.

P/N

- 45-449 Bolt in 9" Ford housing for 93-02 Camaro stock width (requires use of S&W torque arm)
- 45-449N Bolt in 2" NARROWED 9" Ford housing for 93-02 Camaro (requires use of S&W torque arm)
- 45-450 Bolt in 9" Ford housing for 82-92 Camaro stock width (requires use of S&W torque arm)

P/N

- 40-617 Mild Steel Torque Arm, Mounting Bracket and weld on mounting lug kit for use with customer supplied housing (welding required)
- 40-617CM Chrome Moly Torque Arm, Mounting Bracket and weld on mounting lug kit for use with customer supplied housing (welding required)
- 40-618 Mounting Bracket & Weld Lug kit for use on cars already equipped with an S&W torque arm for use with customer supplied housing)
- 40-618K Mounting Bracket kit for use on cars already equipped with an S&W torque arm. (requires use of S&W housing 45-449 or 45-450)
- 40-619 Mild Steel Torque Arm, Mounting Bracket for use with S&W housing 45-449 or 45-450
- 40-619CM Chrome Moly Torque Arm, Mounting Bracket for use with S&W housing 45-449 or 45-450



40-618 shown
Installed on 45-449
Housing

SEE Pg.52
for BOLT-IN / DIRECT
FIT DEM Upgrade
Complete Rears
& Bare Housings



40-617
(shown)

Stocker Wheelie Bar



Features fully welded "k" member and multiple upper point adjustments on the housing mount

More
Wheelie
Bars
on Pg.31

P/N

- 40-327 Unpainted - 82-92 Camaro or Firebird w/ 2-1/2" axle tube
- 40-328 Unpainted - 82-92 Camaro or Firebird w/ 3" axle tube

70-81 Manual Rack & Pinion Steering Conversion Kit

Features: Pinto style manual rack. Bump steer kit. Rack clamp and rack mount plate. Steering shaft & shaft brace. 3 Chrome Moly U Joints.

P/N

35-046 1970-1981 Camaro/Firebird R&P Kit

67-69 Camaro/Firebird Shock Crossmember

Designed to relocate the upper mounts of the rear shock absorbers on a 67-69 Camaro or Firebird. Eliminates mounting shocks through the original sheet metal floor pan which cannot handle the stress of racing.

P/N

40-232 Camaro/Firebird shock crossmember

Torsional Anti-Roll Bar

Great for Stock, Top Stock & Foot Brake classes! Stops body roll & improves 60 foot times.

Fits under stock floor pans. Welding required for installation.

NOTE: STOCK ELIMINATOR RACERS Please Call to Order

P/N

- 40-613 Anti Roll Bar Kit - 82-02 Camaro or Firebird
- 40-613C Anti Roll Bar Kit - 82-02 Camaro - CLAMP ON

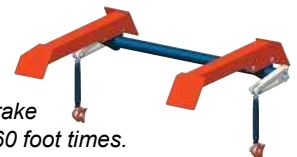

3 Point Subframe Connector 2005 & Newer Mustang

S&W Race Cars new 3 Point Subframe Connectors for the 2005 and newer Mustang are engineered to tie the factory inner frame rail to the lower rear control arm front mounting bolt and the rocker panel, greatly strengthening the lower suspension mounts for high performance use. Connectors are fabricated from chrome moly tubing and come black powder coated. All necessary additional hardware is included.



P/N
40-700 3 Point subframe connectors - pair

Adjustable Upper Control Arm 2005 to 2014 Mustang

S&W Race Cars offers two versions of a fully adjustable upper control arm for the 2005 and newer Mustang. Both are engineered to allow adjustment of both the pinion angle and instant center.

A longer than stock upper link allows for smoother operation of the rear suspension through its travel. The street version offers a polyurethane bushed front link for a quieter ride while the competition version uses a spherical rod end for the ultimate in strength. Both kits come black powder coated and all necessary additional hardware is included.

P/N
40-701 Competition upper control arm (2005-2011)
40-704 Street upper control arm (2005-2011)
40-716 Competition upper control arm (2012 & 2014)
40-717 Street upper control arm (2012 & 2014)

Adjustable Panhard Bar 2005 to 2014 Mustang

S&W Race Cars new fully adjustable panhard for the 2005 to 2014 Mustang is engineered to allow quick adjustment on cars with altered ride heights. Our unique, left/right adjuster allows quick adjustments without removal of the mounting hardware. An upper brace to replace the stock sheet metal brace is also available but not necessary for installation.



Kit features Energy Suspension polyurethane bushings and comes black powder-coated.

P/N
40-703 Adjustable Panard Bar (2005-2014)
40-706 Upper Panard Bar Support (2005-2014)
40-710 Adjustable Chrome Moly Panard Bar (2005-2014)

Bolt-In Driveshaft Loop 2005 - 2014 Mustang

S&W Race Cars bolt in driveshaft loop for the 2005 and newer Mustang Easy bolt in installation requires only drilling of the floor in 4 spots. Black powder-coated

P/N
40-705 Bolt in driveshaftloop



Torsional Anti-Roll Bar 2005 to 2014 Mustang

Stops body roll & improves 60 foot times.

SEE Pg. 37
for 2005
& Newer
Steering Kit



NOTE: STOCK ELIMINATOR RACERS Please Call to Order

S&W's new Mustang anti roll bar uses two top axle tube brackets that weld to the axle tubes allowing the rest of the kit to be bolted in place.

Kit includes all necessary brackets & hardware, splined aluminum arms and a real splined torsion bar (not a piece of moly tubing like many of our competitors).

P/N
40-708 Anti Roll Bar Kit for housings w/ 3" axle tubes (2005-2014)
40-708K Anti Roll Bar Kit for 45-447FAB & 45-448FAB housings (2005-2014)

Lower Control Arms 2005 to 2014 Mustang

Designed to withstand the rigors of weekly bracket racing, without sacrificing ride quality S&W Race Cars 2005 and newer Mustang lower control arms are custom fabricated from super strong, 1-1/2" x .120" wall DOM steel tubing. High quality, Energy Suspension polyurethane bushings are installed in both ends to retain ride quality and eliminate bushing movement. These arms are a direct replacement for the factory control arm and install using the O.E.M. hardware. Also available are chrome moly, fully adjustable lower control arm for applications requiring the ultimate in strength or adjustability. These control arms feature high strength, chrome moly rod ends. Adjustable lower control arms are NOT approved for Stock Eliminator classes. Both are powder coated for a long lasting, durable and attractive finish.



40-702 (shown)
P/N
40-702 Standard lower control arms - pair (2005-2014)
40-709 Chrome Moly adjustable lower control arms - pair (2005-2014)

Shock Tower Brace

S&W Race Cars front strut tower brace for the 2005 to 2014 Mustang The Quick & Easy way to improve handling and stiffen the chassis. Simple 15 minute installation. Black powder-coated

P/N
40-715 2005-2014 Mustang Shock Tower Brace



2005 to 2012 'SWARR' Bar

P/N
45-HB04 Bolt-On Brace for 8.8" Rear (2005 to 2012)



2005 to 2014 MUSTANG BOLT-IN 9" & FABRICATED HOUSINGS

Bolt in replacement for stock 8.8" rear axle housing. Built from NEW big web housing. Shock & control arm brackets in stock location. Lower control arm bracket feature additional holes for suspension adjustment, an extra cost option on our competitors housings. Housing end accepts 3.150" axle bearing. Requires aftermarket axles & brakes. No provision for factory anti roll bar.



45-447
(above)

45-447FAB
(above)



3 position lower control arm mounts standard on either housing!

This is an extra cost option on most other brand housings!

P/N

45-447
45-448

45-447FAB
45-448FAB

Housing, stock width - new style big ford end (2005-2014)
Housing, 2" narrower than stock new style big ford end (2005-2014)
Fab housing, stock width - new style big ford end (2005-2014)
Fab housing, 2" narrower than stock new style big ford end (2005-2014)

1979 - 2004 MUSTANG BOLT-ON'S

1979-1993 Bolt On Subframe Connectors

The only 100% bolt on connector that bolts to the engine k-member in the front and the lower control arm bolt and torque box in the rear!! For added strength this connector also connects to the seat mount bolts. Connectors are available for both the 79-93 Fox Mustang. Powder coated for a long lasting, attractive finish. All necessary hardware included.



P/N

40-720 79-93 Mustang connectors - bolt on

Adjustable Upper Control Arms 79-04 Mustang

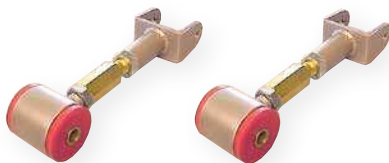

Fully Adjustable • Street & Competition versions available

Powder coated for an attractive, durable finish.
All Hardware Included

P/N

40-723
40-724

Competition upper control arm kit
Street upper control arm kit

40-724 Street version uses Energy Suspension bushing for a quiet ride

1979-2004 Tubular Lower Control Arms

S&W Race Cars new 79-02 Mustang lower control arms are perfect for ET bracket and Stock Eliminator racing. Each set is custom fabricated from super strong, 1-5/8" x .134" wall steel tubing (the same tubing that is standard in S&W Race Cars' 10 point roll cages). High quality, Energy Suspension polyurethane bushings are installed in both ends to retain ride quality and eliminate bushing movement. These arms are a direct replacement for the factory control arm and install using the O.E.M. hardware. Powder coated for a long lasting, durable and attractive finish. S&W Race Cars new 79-04 Mustang weight jacker control arms are perfect for ET bracket racing as well as high performance street use. Each set is custom fabricated and fully adjustable to allow the racer the ultimate in "tunability". S&W's unique spanner adjuster makes weight jacking quick & easy. Each set of control arms includes its own tool set. These arms are a direct replacement for the factory control arm and include all necessary mounting hardware. Powder coated for a long lasting, durable and attractive finish. Weight jacker control arms ARE NOT accepted for NHRA Stock Eliminator

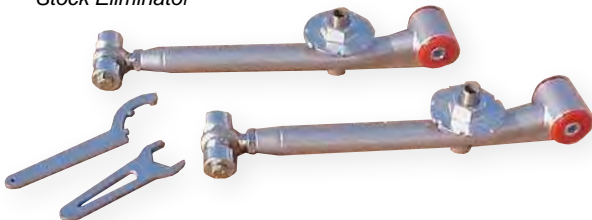

P/N

40-721
40-722
40-725

Lower control arms - pair
Lower control arms with factory sway bar mount- pair
Weight jacker lower control arms - pair

79-04 Mustang O.E.M Control Arm Stiffening Kit

Perfect for Mustang racers on a budget or for classes where replacing your stock control arms is not permitted. the S&W stiffening kit simply welds to the factory control arms converting them into strong, fully boxed suspension members. Sold in a set for 2 upper & 2 lower arms. Welding required.

P/N

40-729 Control arm stiffening kit



86-04 'SWARR' Bar



P/N

45-HB02 Bolt-On Brace for 8.8" Rear (86-04)





PRO-TOURING WELDED REAR FRAME & SUSPENSION SYSTEM

Standard ProTouring System Includes

- Welded Crossmember & Frame Rails • Rear Housing
- 3-Link Suspension • Panhard Bar • Shocks & Springs • Hardware

• Pro-Touring System



All S&W Rod Pkg's. on This Page are \$ ITEMS



SEARCH P/N 10-550

STREET ROD 4-BAR & REAR SUSPENSION KITS

Street Rod 4-Bar Package with Poly Bushings & Pro Series Shocks Includes

- (4) Links with Poly Bushings & Steel Sleeves • Frame & Rear Housing Brackets
- Dropped Crossmember (P/N 40-209-3 3" Drop, 63" Wide) • Link Length Adjustable 19.5" - 20.5"
- Centerline of Axle to Front of Crossmember 22.5" - 23.5" • Pro-Shock & Spring Kit, with your choice of Spring Rate and Lower Mounts (P/N 40-223L- XXX # Spring) • Track Bar Kit (P/N 40-213) • Upper Shock Crossmember Tube



SEARCH P/N 40-125-A

• SR 4-Bar Package with Pro Series Shock

Street Rod 4-Bar Package with QA-1 Shocks & Chrome Springs Includes

- (4) Links with Poly Bushings & Steel Sleeves • Frame & Rear Housing Brackets
- Dropped Crossmember (P/N 40-209-3 3" Drop, 63" Wide) • Link Length Adjustable 19.5" - 20.5"
- Centerline of Axle to Front of Crossmember 22.5" - 23.5" • QA-1 Single Adjustable Shocks (P/N 50-019A)
- 12" Chrome Springs with your choice of Spring Rate (50-12CS- XXX # Spring)
- Low Rider Adjustable Rear Shock Mount Kit (P/N 40-224) • Track Bar Kit (P/N 40-213)
- Upper Shock Crossmember with Tabs with Hardware (P/N 40-220)



SEARCH P/N 40-125-B

• SR 4-Bar Package with QA-1 Shocks & Chrome Springs

Street Rod 4 Bar

S&W's street rod 4 bar is fully adjustable and features precision cut brackets and high strength polyurethane ends for a smooth, quiet ride. Kit is available with or without a 2" x 3" rectangular front crossmember. Simply add a panhard bar and your favorite coil-over shocks and you're all set. **CAUTION!! This 4 bar is designed for street use and should not be used on vehicles in competition!!**

- [P/N 40-124](#) Street 4 bar w/o crossmember
- [P/N 40-125](#) Street 4 bar with 2x3 crossmember
- [P/N 40-129](#) Panhard kit with poly bushed ends



RAT ROD BAR & REAR SUSPENSION KITS

42" Rat Rod Ladder Bar Package with Poly Bushings & Pro Series Shock Kit Includes

- 42" from Center Line of Rear to Center Line of Front Crossmember • Front has Poly Bushings
- Rear of Bar Mounts to .375" Housing Brackets with Threaded Clevis
- 1.75" Diam. X 60" Long Crossmember • Front Mounting Brackets
- Rear Housing Mounting Brackets • Poly Bushings & Hardware • Black Powder Coated
- Pro-Shock & Spring Kit, with your choice of Spring Rate and Lower Mounts (P/N 40-223L- XXX # Spring)
- Adjustable Street Rod Panhard Bar Kit (P/N 40-129) • Upper Shock Crossmember Tube



SEARCH P/N 40-134-A

• RR Ladder Bar Package with Pro Series Shock

42" Rat Rod Ladder Bar Package with QA-1 Shocks & Chrome Springs Includes

- 42" from Center Line of Rear to Center Line of Front Crossmember • Front has Poly Bushings
- Rear of Bar Mounts to .375" Housing Brackets with Threaded Clevis • 1.75" Diam. X 60" Long Crossmember
- Front Mounting Brackets • Rear Housing Mounting Brackets • Poly Bushings & Hardware
- Black Powder Coated • QA-1 Single Adjustable Shocks (P/N 50-019A)
- 12" Chrome Springs with your choice of Spring Rate (50-12CS- XXX # Spring) • Low Rider Adjustable Rear Shock Mount Kit (P/N 40-224)
- Upper Shock Crossmember with Tabs with Hardware (P/N 40-220)
- Adjustable Street Rod Panhard Bar Kit (P/N 40-129)



SEARCH P/N 40-134-B

• RR Ladder Bar Package with QA-1 Shocks & Chrome Springs

Rat Rod Ladder Bar System

S&W's NEW "RAT ROD" ladder bar system features high strength polyurethane front ends for a smooth, quiet ride. Made of the same high strength tubing as our competition ladder bars, S&W's new RAT ROD bar provides the old time look made popular by the rat rod, street rod movement. Bar is 42" long and mounts at the rear with 3/8" housing brackets and threaded clevis's Kit includes a 1-3/4" diameter 60" front crossmember and front mounts. Rat Rod bars are black powder-coated for a clean durable finish Simply add a panhard bar and your favorite coil-over shocks and you're all set.

CAUTION!! Rat Rod Bars are designed for street use and should not be used on vehicles in competition!!

- [P/N 40-134](#) Rat Rod Bar Kit with Crossmember
- [P/N 40-129](#) Street Rod Panhard Kit adjustable with poly bushed ends



** S-10 Trucks & Specialty **

HUGE On-Line Category

Street & Strip

SHOP 24 hours/365 Days!



Call for Quote

The S&W 2 x 3 Universal Lower Welded Frame Kit

Can be made to fit S10's and/or Any Car or Truck

(2x3 Roller Chassis Shown)

S10 RACK & PINION STEERING CONVERSION KIT



P/N 35-045



BARE FRAMES



UPPER & LOWER TUBULAR A-ARM KITS



Upper & Lower Kits
(Upper & Lower Also Avail. Separately)

FIBERGLASS Body Parts Hoods, Doors & Front End



1994 - 2002 MARGUARD REAR WINDOW KIT



P/N 95-610 (Clear)

P/N 95-610T (Tinted)

S10 RADIATOR REPLACEMENT



P/N 95-80240

Mopar - Dodge - Chrysler - Plymouth

Check Out Our On-Line Category

A Body / B Body / E Body

A-Arm Kits / K Members

Frame Rails / Frame Connectors

Direct Fit Roll Bars & Roll Cages



Gary & Pam Beineke



Road Racing - SCCA - CHUMPS - LeMONS - Track Day - Rally

Check Out Our On-Line Category

SCCA Cage Upgrade

LeMons & CHUMP Cages

HANS / Nets / Safety Access.

EASY D-I-Y Bolt On's



John Burke



Shawn Mellinger

JEEP - 4X4 - OFF ROAD - MUD TRUCK

Check Out Our On-Line Category

Motor Plates / Mid Plates

Ladder Bars / Track Bars / Housings

Frame Rails / Frame Connectors

Direct Fit Roll Bars & Roll Cages

Tie Downs / Window Nets



social @SWRACECARS

website SWRACECARS.COM

GM & FORD BOLT-ON REAR CONTROL ARMS

S&W Race Cars bolt on upper & lower control arms are available in either fixed length or fully adjustable versions. They are direct replacements for OEM versions and most install using factory hardware. (hardware included when necessary) For the weight conscious racers most models are available in chrome moly versions. Adjustable lowers are not acceptable for NHRA Stock Eliminator. Street versions feature Energy Suspension bushings for a smooth quiet ride. Competition versions feature rod ends and aluminum bushings for maximum strength.



All S&W GM & FORD Bolt-On Rear Control Arms on This Page are \$ ITEMS



Bob Hoffman

- P/N
- 40-615 Vega - Monza, standard lower control arms
 - 40-620 64'-72' GM "A" body (Chevelle), standard lower control arms
 - 40-621 78'-88' GM "G" body (Malibu/Monte Carlo), adjustable street upper control arms
 - 40-622 78'-88' GM "G" body (Malibu/Monte Carlo), adjustable competition upper control arms
 - 40-623 82'-02' GM "F" body (Camaro) and 78'-88 GM "G" body (Malibu/Monte Carlo), competition chrome moly adjustable lower control arms
 - 40-602 82'-02' GM "F" body (Camaro) and 78'-88 GM "G" body (Malibu/Monte Carlo), street, non-adjustable lower control arms
 - 40-602CM 82'-02' GM "F" body (Camaro) and 78'-88 GM "G" body (Malibu/Monte Carlo), street or Stock Eliminator, non-adjustable chrome moly lower control arms
 - 40-624 64'-72' GM "A" body (Chevelle), adjustable chrome moly lower control arms
 - 40-625 64'-67' GM "A" body (Chevelle), adjustable competition upper control arms
 - 40-626 64'-67' GM "A" body (Chevelle), adjustable street upper control arms
 - 40-627 68'-72' GM "A" body (Chevelle), adjustable competition upper control arms
 - 40-628 68'-72' GM "A" body (Chevelle), adjustable street upper control arms



40-621 (shown)

40-622 (shown)



40-602 (shown)

40-602CM (shown)

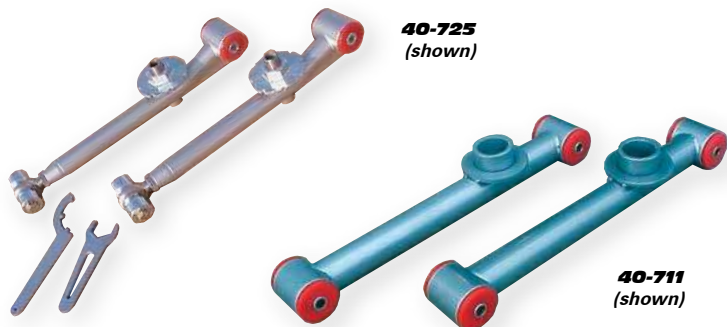

40-725 (shown)

40-711 (shown)



John Hummel



40-709 (shown)

- P/N
- 40-701 05'-14' Mustang, competition upper control arm
 - 40-702 05'-14' Mustang, standard lower control arms
 - 40-704 05'-14' Mustang, street upper control arm
 - 40-716 11'-14' Mustang, competition upper control arm
 - 40-717 11'-14' Mustang, street upper control arm
 - 40-709 05'-14' Mustang, moly adjustable lower control arms
 - 40-723 79'-04' Mustang, competition adjustable upper control arm kit
 - 40-724 79'-04' Mustang, street adjustable upper control arm kit
 - 40-721 79'-04' Mustang, Lower control arms - pair
 - 40-722 79'-04' Mustang, Lower control arms with factory sway bar mount- pair
 - 40-725 79'-04' Mustang, Weight jacker lower control arms - pair

Pro/Series Ladder Bars

Selling only one length ladder bar would be like building headers from only one diameter tubing - IT JUST WOULDN'T WORK!! Different combinations require different length ladder bars. That is why S&W Race Cars sells ladder bars in 28, 32" & 36" lengths. 28" bars are designed for rear wheel drive Sport Compact and Imports, while the 32" & 36" bars are designed for use on longer wheelbase applications. S&W ladder bars are jig constructed from 1" x .156" wall mild steel tubing that is internally threaded. Each bar is attached to the rear housing between two 1/4" steel brackets that provide 200 degrees of welding surface. Two spherical rod ends 3/4" thread with a 5/8" hole, four (4) solid rod ends, safety brackets, rear housing brackets and hardware are included.

P/N

- 40-104T 32" Double adjustable with Teflon rod ends
- 40-104 32" Double adjustable with Standard rod ends
- 40-105 32" Double adjustable with Chrome-moly rod ends
- 40-106T 36" Double adjustable with Teflon rod ends
- 40-107 36" Double adjustable with Chrome-moly rod ends

P/N 40-1080 CUSTOM BARS AVAILABLE. Call 1-800-523-3353

Sport Compact Ladder Bar

S&W's 28" Sport Compact/Import ladder bar is perfect for short wheelbase light weight RWD imports & sport compacts. These ladder bars incorporate all the same great features as the ladder bars shown above.

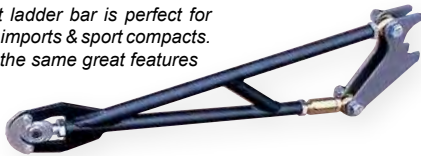

P/N

- 40-131 28" D/A Sport Compact with chrome-moly rod ends

Ultimate Ladder Bar

S&W's New Ultimate Ladder Bar is built to take all the punishment you can throw at it. Fully .tig welded of 1-1/4" x .095" wall chrome moly tubing. chrome moly hex adjuster and chrome moly housing brackets offer strength and quality unequaled by any other ladder bar. FK Bearing front rod ends are rated at 40,590 lbs. radial static load and ultra strong solid rod eyes in back along with front safety brackets and grade 8 hardware throughout finish the package. Available in only 32" length (as measured from the center of the front rod end to the center of the axle housing tube) , S&W's new Ultimate Ladder Bar is perfect for Outlaw 10.5 car or cars where pavement pounding performance is expected.



P/N

- 40-133 Ultimate ladder bar (pair)

Off Road Ladder Bar

If "off roading" is your thing, be it on the dunes, crawling over rocks or blazing new trails through the woods, you need a suspension built to withstand the torture you put it through! S&W's new 32" Off-Road Ladder Bar is built to take all the punishment you can throw at it. Fully .tig welded of 1-1/4" x .095" wall chrome moly tubing. with mild steel housing brackets, 3/4" x 3/4" FK Bearing front rod ends and ultra strong 3/4" x 3/4" solid rod eyes in back along with front safety brackets and grade 8 hardware throughout finish the package. Available in only 32" length (as measured from the center of the front rod end to the center of the axle housing tube).



***Designed for HI-GROUND* CLEARANCE Vehicles**

P/N

- 40-132 Off-Road ladder bar (pair)
- 40-245 Off-Road ladder bar front crossmember

Gasser Bars

Join the nostalgia craze with the addition of S&W Race Cars "gasser bars" to your hot rods rear suspension. Made of the same high strength tubing as our full competition ladder bars, the gasser bar features a polyurethane front mount for a secure and quiet ride on the street. A full 42" long these bars offer both suspension control and the nostalgia appearance that is very popular today. Front mounting is made simple with an optional 2" x 3" rectangular or 1-3/4" round tube crossmember.

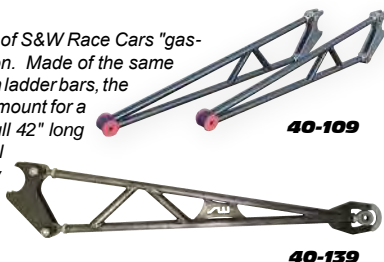

P/N

- 40-109 Gasser Bars
- 40-139 Gasser Bars (Chrome Moly)

Choosing Ladder-Bar Lengths

TECH TIP

Ladder bar length is directly related the wheelbase of the vehicle it is being used on. As a general rule, we have found that the shorter the wheelbase the shorter the ladder bar. S&W now offers a 28" bar designed specifically for the sport compact & import racer. 32" bars are most commonly used on cars such as Camaros, Mustangs & Cudas while longer wheelbase cars or cars that are extremely nose heavy seem to respond better with a 36" ladder bar. Shorter wheelbase cars, such as Vegas, Pintos & Daytonas, work well with 32" ladder bars but due to space limitations between the axle centerline and the drivers seat placement, may be better suited for a 4-link application. Length is CL Axle to CL Rod End

1" x .156" wall, direct threaded DOM tubing

Black powder coated for a durable, attractive finish

45-104 (shown)

1/4" double shear housing brackets

Optional, lower bar adjuster on double adjustable ladder bars

Front safety brackets installed High Strength Chrome Moly Rod Ends

Ladder Bar Crossmembers

S&W ladder bar crossmembers are made from either 1-3/4" x .134" wall or 2" x 3" .120" wall tubing. These crossmembers will securely mount the front of the ladder bar assembly and resist the likelihood of twist or flex which is common in lesser quality crossmembers. These crossmembers feature four 1/4" steel brackets with five separate, 5/8" holes for chassis tuning. Round tube crossmember is 54-5/8" wide. 2" x 3" crossmember is 63" wide. All necessary brackets and hardware are included. Now available is a crossmember specifically for pick up's where more drop in necessary for proper installation. ALL SHIPPED with BARE FINISH.

P/N

- 40-204 Ladder bar crossmember and brackets 4in Drop (2"x3")
- 40-209 Ladder bar crossmember and brackets 3in Drop (2"x3")
- 40-210 Ladder bar crossmember (54-5/8") & brackets (round)
- 40-210V Vega L/B crossmember for use with 10-013 rails
- 40-210W Ladder bar crossmember (59") & brackets (round)
- 40-244 Ladder bar crossmember and brackets (truck)

Ladder Bar Safety Brackets

Universal design intended for use on ladder bars that are not equipped with safety brackets. These brackets are designed to safely retain the ladder bar on the car in the event of front rod end failure. Welding required.

P/N

- 40-212 Weld-on safety bracket kit

Ladder Bar Adjuster Kit

This kit will convert any standard S&W ladder bar to the double adjustable style or any ladder bar made from 1" x .156 wall tubing. Requires a 3/4"-16 left hand tap for installation (not included).

P/N

- 40-214 Ladder bar adjuster kit

Housing Floaters

A must for any leaf spring car utilizing a ladder bar or 4-link suspension. S&W floater kits are designed to eliminate suspension bind and maximize weight transfer. Units fit Ford, GM, Dana, and 8-3/4" Mopar with 3" axle tubes. All hardware included.

P/N

- 40-230 3" Floater kit
- 40-271 3-1/4" Floater kit
- 40-263 3-1/2" Floater kit

Offset Spring Hangers

Originally created for Super Stock classes, S&W's offset spring hangers are designed to relocate the rear of the leaf spring inboard for additional tire clearance. Sold in pairs, some welding required. Kit fits - 67-69 Camaro 62-67 Chevy II & 68-74 Nova

P/N

- 40-231 Offset spring hanger kit



REAR SUSPENSION COMPONENTS

PRO 500 4-Link

All New P-5 4-Link Package Features:

- 1/2" bolt holes front & rear for more instant center possibilities! Note: each 4-link is available alone or installed as part of our welded P-5 round tube frame package (See page 6)
- 1-3/8" Chrome Moly bottom & 1-1/4" Chrome Moly top tubes.
- Premium Chrome Moly FK Rod Ends with 3/4" threads & 1/2" holes providing the highest strength rod end combo possible.
- P-5 4-Link is available with 3/16" Mild Steel Chassis & Housing brackets -or- 3/16" Chrome Moly Chassis & Housing brackets.

If you need Ultimate Strength, an optional doubler kit is available for the chassis & housing brackets!

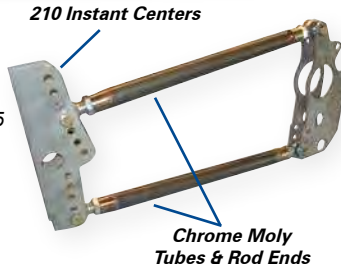

P/N	
40-137	Mild Steel Chassis brackets, MS Housing brackets, CM Tubes w/CM Rod End Pkg.
40-137SM	Mild Steel Chassis brackets w/integral shock mount, MS Housing brackets, CM Tubes w/CM Rod End Pkg
40-137CM	Chrome Moly Chassis brackets & CM Housing brackets, CM Tubes w/CM Rod End Pkg.
40-137SMCM	Chrome Moly Chassis brackets w/integral shock mount, CM Housing brackets, CM Tubes w/CM Rod End Pkg
40-135DBL	Mild Steel - Bolt Hole Doubler Set
40-135CM- DBL	Chrome Moly - Bolt Hole Doubler Set
40-136	Moly Rod End Package 3/4" x 1/2"
40-121	Rod End package for 40-117 & 40-118 Chrome Moly

Laser Link 4-Link Suspension System

The S & W laser link features the optimum in tuning adjustments, 144 possible instant centers. Also featured are laser cut frame and housing brackets with 5/8" holes for greater strength. The laser link features heavy duty, 1"x.156" wall links. Links are direct threaded 3/4-16L.H. on one end & 3/4-16R.H. on the other and feature oversize hex nuts for quick, easy adjustments. Each laser link comes complete with grade 8 hardware. 4-links may be purchased with or without rod ends. S&W insists that only chrome-moly rod ends be used with any 4-link system.

P/N	
40-112	Street/roadster laser link less rod ends
40-113	Street/roadster laser link with chrome-moly rod ends
40-116	Pro Laser link 4-link with chrome-moly rod ends
40-117	Pro Laser link 4-link less rod ends
40-118	Laser link 4-link less rod ends
40-118SM	Laser link 4-link with shock mount bracket - less rod ends

Rear Torsional Anti-Roll Bars



By equalizing traction & preventing body roll, anti-roll or rear torsion bars, as they are sometimes called, have been shown to produce consistently quicker 60' times. 1-1/8" bars are perfect for high torque applications with severe body roll. Both kits use only the highest quality components - a splined 4340 steel torsion shaft (not a piece of tubing as used by some of

our competitors), splined & machined, billet arms, mounting tube & supports, plus all necessary rod ends, links and hardware.

Custom Sizes Available
Note: 4-6+ Week Lead Time

P/N	18.5" Length
40-090	18.5" Anti Roll Bar Kit (1-1/8" bar) (Also fits: 24" S&W frames and S&W #10-400 / #10-508 frame kits)
P/N	21" Length
40-091	21" Anti Roll Bar Kit (1-1/8" bar) (Also fits: 26" S&W frames and S&W #10-401 frame kit)
P/N	23" Length
40-092	23" Anti Roll (1-1/8") Kit (Also fits: 28" S&W frames and S&W #10-402 frame kit)
P/N	29" Length
40-614	29" Anti Roll Bar Kit (1-1/8" bar)
P/N	Direct Fit & Replacement Bushings
40-097	Anti Roll (1-1/8") for 10-507 frame
40-613	Anti Roll Bar assembly for 82-02 Camaro
40-613C	Anti Roll Bar assembly for 82-02 Camaro CLAMP ON
40-708	Anti Roll Bar assembly for 05-14 Mustang
40-708K	Anti Roll Bar assembly for use with 45-447Fab or 45-448Fab Housings
40-904	S&W Dragster/Roadster Anti Roll Bar assembly
40-905	Aero Roadster Anti Roll Bar assembly
40-900	Replacement bushing - 7/8" bar/1-1/4" main tube
40-901	Replacement bushing - 7/8" bar/1-1/2" main tube
40-902	Replacement bushing - 1-1/8" bar/1-1/2" main tube

Ultra Pro Laser Link 4-Link

The "Ultra-Pro" laser link 4-link system from S&W Race Cars features the optimum in tuning adjustments, 144 possible instant centers and is designed to withstand even the most severe drag race applications. The top bars are 1-1/4" x .095" 4130 chrome moly tubing and the bottom bars are 1-3/8" x .095" 4130 chrome moly tubing. Weld in tube adapters feature wrench flats for easy adjustability. All brackets are 4130 chrome moly steel and precision, waterjet cut with 5/8" holes for super strength and a wide range of adjustments. Also included is a 1-1/4" chrome moly, cross tube to reinforce the brackets and housing. Grade 8 hardware is included and kits are available with or without high-quality 4130, chrome-moly spherical rod ends. A tube upgrade kit is available to update your existing S&W laser-link. S&W insists that only 4130 chrome-moly rod ends be used with any 4-link system.

This 4-link package features all 4130 chrome-moly brackets, tubes & threaded tube ends. Installation requires TIG welding for proper installation and assembly. **Failure to use a TIG welder could lead to component failure**

P/N	
40-110	Ultra Pro 4-link with moly rod ends
40-110SM	Ultra Pro 4-link with moly rod ends with integral shock mount bracket
40-111	Ultra Pro 4-link less moly rod ends
40-111SM	Ultra Pro 4-link less moly rod ends with integral shock mount bracket
40-111U	Unwelded Chrome Moly Tube Upgrade Kit
40-111W	Welded Chrome Moly Tube Upgrade Kit
40-1111	1-1/4" Diam. CM Tube w/welded ends
40-1112	1-3/8" Diam. CM Tube w/welded ends

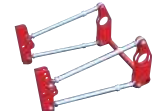

P/N	
40-119	Laser link 4-link with chrome-moly rod ends
40-119SM	Laser link 4-link with integral shock mount bracket - with chrome-moly rod ends
40-121	Rod End package for 40-117 & 40-118 Chrome Moly
40-122	Laser link package for use with 10-011 Corvette frame package - less rod ends
40-123	Laser link package for use with 10-011 Corvette frame package with chrome-moly rod ends

4-Link Tools

More Tools on Pg.13

P/N	
95-027	Tube adjusting jig
95-022	Instant center plotting kit 5/8" Holes
90-022	4-link bracket spacer kit

Swing Arm Kits

Swing Arm Kits Include: Chrome Moly Tubular Lower Swing Arm, Chrome Moly Upper Links with Right Hand & Left Hand threaded Tube Ends & Rod Ends.

Dragster Technology for Your Door Car!

P/N	
40-1410	Custom Swing Arm to customer specification with out hardware & Chrome-Moly Rod Ends

P/N
Includes Rod End Size: 3/4" Dia. Shank & 1/2" Dia. Hole for Chassis and Rear Housing Brackets.

40-142	22" Swing Arm with Chrome Moly Rod Ends
40-144	24" Swing Arm with Chrome Moly Rod Ends
40-146	26" Swing Arm with Chrome Moly Rod Ends
40-148	28" Swing Arm with Chrome Moly Rod Ends

P/N
Includes Rod End Size: 3/4" Dia. Shank & 5/8" Dia. Hole for Chassis and Rear Housing Brackets.

40-143	22" Swing Arm with Chrome Moly Rod Ends
40-145	24" Swing Arm with Chrome Moly Rod Ends
40-147	26" Swing Arm with Chrome Moly Rod Ends
40-149	28" Swing Arm with Chrome Moly Rod Ends



Upper Links Included with all Swing Arm Kits (They can be excluded from the Kit if specified when ordering)

REAR SUSPENSION COMPONENTS

Wishbone Kits

The ultimate in rear housing locators, the wishbone offers virtually no resistance or bind through the entire range of rear suspension travel. S&W offers both bolt on & weld on wishbone kits.

P/N

- 40-236 Wishbone kit, unwelded, bolt-on
- 40-237 Wishbone kit, fully welded, weld-on
- 40-237CM Wishbone kit, fully welded, weld-on (moly ends)
- 40-238 Wishbone kit, unwelded, weld-on
- 40-238CM Wishbone kit, unwelded, weld-on (moly ends)
- 40-251 Pro-500 wishbone kit, unwelded, chrome moly, bolt-on
- 40-254 Pro-500 wishbone kit, Welded



40-254 (shown)



40-237 (shown)

Track Locators & Panhard Bars

Track locator bars are designed for use on drag race only vehicles with coil-over shocks and either ladder bar or 4-link rear suspension. This locator stops lateral movement and centers the rear housing under the vehicle. Panhard bars serve the same purpose but are designed for use on any vehicle where cornering loads are present. S&W track locators & panhard bars feature: 7/8"x.065" wall chrome-moly tubing with threaded tube ends, mounting brackets, two (2) spherical rod ends and hardware. **HEAVY DUTY Panhard Bar** features: 3/4" Chrome Moly Rod End with 5/8" HOLE & Chrome Moly 3/4" Threaded Tube Ends, 3 ft. of 1-1/4" Diam. .095" wall Chrome Moly Tubing. **HEAVY DUTY Track Bar** features: 3/4" Chrome Moly Rod End with 5/8" HOLE & Chrome Moly 3/4" Threaded Tube Ends, 4 ft. of 1-1/4" Diam. .095" wall Chrome Moly Tubing.



40-217 (shown)

- 40-213 Bolt-on track locator bar kit (5/8" x 5/8")
- 40-215 Weld-on track locator bar kit Fits all S&W ladder bars made after 3-1-96
- 40-216 Bolt-on track locator bar kit (3/4" x 5/8")
- 40-217 Bolt-on track locator bar kit (3/4" x 3/4")
- 40-218 Panhard bar kit
- 40-218T Panhard bar kit with Teflon rod ends
- 40-219 Welded panhard bar for 10-500 & 10-501 rear frames
- 40-219T Welded panhard bar for 10-500 & 10-501 rear frames with Teflon rod ends
- 40-233 Heavy Duty bolt on track locator
- 40-261 Heavy Duty Panhard Bar Kit (must be TIG Welded)
- 40-265 Heavy Duty Track Bar Kit 5/8" x 3/4"
- 40-300 Welded track locator for 10-300 rear frame
- 40-301 Welded track locator for 10-301 rear frame
- 40-302 Welded track locator for 10-302 rear frame
- 40-400 Welded track locator for 10-400 rear frame
- 40-401 Welded track locator for 10-401 rear frame
- 40-402 Welded track locator for 10-402 rear frame
- 40-403 Welded track locator for 10-500 & 10-501 rear frames
- 40-404 Welded track locator for 10-502, 10-503 & 10-505 rear frames
- 40-405 Welded track locator for 10-504 rear frame
- 40-406 Welded track locator for 10-507 rear frame
- 40-502 Panhard bar for 10-502 rear frame
- 40-502T Panhard bar for 10-502 rear frame with Teflon rod ends
- 40-503 Panhard bar for 10-503, 10-504 & 10-505 rear frame
- 40-503T Panhard bar for 10-503, 10-504 & 10-505 rear frame with Teflon ends
- 40-506 Panhard bar for 10-506 rear frame
- 40-506T Panhard bar for 10-506 rear frame with Teflon ends

↑ Add HD after P/N for Heavy Duty Track Locator ↓

TECH TIP

Panhard Bar or Track Locator?

This is one of the most frequently asked questions when purchasing a rear frame package. While both serve the same function, to center the rear axle housing under the car, as a general rule S & W recommends a panhard bar for any vehicle where cornering loads will be present. Panhard bars are mounted from the frame rail to the axle housing, above and parallel to the axle centerline, and supply the required lateral stability without any chance of suspension bind during cornering. A track locator bar is used to connect the front and rear lower ladder bar tubes or the opposing 4-link bars to control lateral movement and provide optimum straight-line tracking. The lower mounting height makes a track locator ideal for today's race cars. Spherical rod ends are used on all S & W panhard bars and track locators to provide maximum strength, durability and ease of adjustment.

REAR SUSPENSION PACKAGES

Laser Link 4-Link

Package Includes

- Laser/link 4-link (less rod ends)
- Bolt-on Track Locator or Panhard Bar
- Pro/Series 2000 Shock & Spring Mount Kit

Laser link 4-Link Package with Chrome Moly Rod Ends

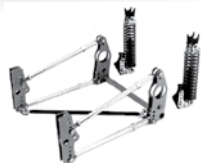

Ladder Bar

Package Includes

- 32" or 36" Double Adj. Ladder Bars
- Bolt-on Track Locator or Panhard Bar
- Pro/Series 2000 Shock & Spring Mount Kit
- Ladder Bar Crossmember

Ladder Bar Package



Ranger Pick-Up

For years, Ford mini-truck owners have been asking us for a rear frame package for their Ranger pick-ups like the one we make for the Chevy S-10. You don't need one! The frame rails on the Ranger are already narrow enough to allow the installation of 13" x 31" Goodyears once the leaf springs are removed. S&W Race Cars has made it easy to install ladder bars and coil over shocks, eliminating the factory leaf springs and providing the room for big tires.

40-207-Package Includes:

- 32" Double Adjustable Ladder Bars
- Ranger crossmember kit
- Pro/Series 2000 Shock & Spring Kit
- Track locator bar

40-207-PACKAGE Ranger Ladder Bar Package

40-207 Ranger Crossmember Kit

9" Ford Rear Housing for Ranger



Street Rod 4 Bar

40-125 (shown)

S&W's street rod 4 bar is fully adjustable and features precision cut brackets and high strength polyurethane ends for a smooth, quiet ride. Kit is available with or without a 2" x 3" rectangular front crossmember. Simply add a panhard bar and your favorite coil-over shocks and you're all set. **CAUTION!!** This 4 bar is designed for street use and should not be used on vehicles in competition!!



P/N

- 40-124 Street 4 bar without crossmember
- 40-125 Street 4 bar with 2x3 crossmember
- 40-129 Panhard kit with poly bushed ends

Rat Rod Ladder Bar System

S&W's NEW "RAT ROD" ladder bar system features high strength polyurethane front ends for a smooth, quiet ride. Made of the same high strength tubing as our competition ladder bars, S&W's new RAT ROD bar provides the old time look made popular by the rat rod, street rod movement. Bar is 42" long and mounts at the rear with 3/8" housing brackets and threaded clevis's. Kit includes a 1-3/4" diameter 60" front crossmember and front mounts. Rat Rod bars are black powder-coated for a clean durable finish. Simply add a panhard bar and your favorite coil-over shocks and you're all set.



CAUTION!! Rat Rod Bars are designed for street use and should not be used on vehicles in competition!!

P/N

- 40-134 Rat Rod Bar Kit with Crossmember
- 40-129 Street Rod Panhard Kit adjustable with poly bushed ends



Coil-Over Race Springs

S&W stocks a variety of different rate springs for Koni or QA1 shocks and our Pro/Street shock and spring kit. Springs measure 7" x 2-1/2" I.D. for front shocks and 12" x 2-1/2" I.D. for rear shocks. All springs feature a PVC coating which prevents rust and provides a more attractive appearance when installed. All springs sold "each"

<u>P/N</u>	
50-029	250# front spring (7 inch)
50-030	300# front spring (7 inch)
50-031	350# front spring (7 inch)
50-032	450# front spring (7 inch)
50-041	550# front spring (7 inch)
50-043	400# front spring (7 inch)
50-033	80# rear spring (12 inch)
50-034	95# rear spring (12 inch)
50-035	110# rear spring (12 inch)
50-036	130# rear spring (12 inch)
50-037	150# rear spring (12 inch)
50-038	170# rear spring (12 inch)
50-039	200# rear spring (12 inch)
50-040	250# rear spring (12 inch)
50-050	110# rear spring (14 inch)
50-046	130# rear spring (14 inch)
50-047	150# rear spring (14 inch)
50-048	175# rear spring (14 inch)

CALL 800-523-3353 for More Rates & Sizes

Shock Spanner Wrench

New spanner set fit Strange and QA-1 coil overs. Two wrenches insure a positive "lock" of the adjuster & lock ring. Say good-bye to loosening adjusters with this handy spanner set

<u>P/N</u>	
50-025	Shock spanner wrench set



Adjustable Lower Rear Shock Mount Kits

S&W's lower adjustable shock mount kits provide the flexibility needed for race car fabrication. S & W now offers kits with 5" and 7-1/2" of ride height adjustment. Kit includes all hardware.

<u>P/N</u>	
40-221	Lower adjustable rear shock mount for use with 2x3 back brace 5" adjustment
40-221K	L-Shaped brackets & hardware. No weld on housing bracket.
40-222	Lower adjustable rear shock mount 5" adj
40-224	Lower adjustable rear shock mount 7-1/2" adj
40-229	Lower adjustable rear shock mount for use with 2x3 back brace 7-1/2" adjustment



Mock Shock Fixture

These handy shock fixtures are set at 11-1/4" or 13-1/2" and are perfect for replacing & protecting your expensive coil over shocks during the construction process. Sold in pairs and zinc plated for an attractive, long lasting finish.

<u>P/N</u>	
90-020	Mock shocks (13-1/2")
90-024	Mock shocks (11-1/4")



10 inch Springs Available



Chrome Coil-Over Springs

<u>P/N</u>		
50-12CS095	95# chrome rear spring (12 inch)	
50-12CS125	125# chrome rear spring (12 inch)	
50-12CS150	150# chrome rear spring (12 inch)	
50-12CS175	175# chrome rear spring (12 inch)	

Coil Over Thrust Bearing Kit

Use of these torrington type bearings on the lower seat greatly simplifies adjustment of the coil over spring. Eliminates galling of the mount by eliminating friction. Sold each.

<u>P/N</u>	
50-028	Coil over thrust bearing kit



Upper Shock Crossmember

Designed for use with upper eye mount shocks, the S&W upper shock crossmember welds between the frame rails, increasing chassis rigidity while providing a strong top shock mount.

<u>P/N</u>	
40-220	Rear upper shock mount & crossmember



Leaf Spring Housing Mount

This spring pad, for 3" diameter axle housings, eases the problems of installing a new rear in leaf spring vehicles. Will require modifications for use with housings with other than 3" diameter axle tubes. Sold in pairs.

<u>P/N</u>	
40-228	Leaf spring perches



67-69 Camaro/Firebird Shock Crossmember

Designed to relocate the upper mounts of the rear shock absorbers on a 67-69 Camaro or Firebird. Eliminates mounting shocks through the original sheet metal floor pan which cannot handle the stress of racing.

<u>P/N</u>	
40-232	Camaro/Firebird shock crossmember



Camaro Bolt-On's Pg.38 & 39

Pro/Street Coil Spring Mount & Shock Kit

The S & W coil spring and shock kit is designed as a low cost alternative for more expensive, "true" coil-over shocks, while providing many of the same benefits. The kit features a nonadjustable, OEM style shock, and is great for Pro/Street applications. This kit is great for entry level bracket racing and the Pro/Streeteer desiring a little more adjustability. This kit uses the same 12" x 2.5" ID coil springs used on Koni, QA-1 or Strange coil-overs. The coil spring is mounted over the shock, to give you the appearance of coil-over shocks at a fraction of the cost. Kit comes complete with shocks, springs, 5" or 7-1/2" adjustable lower shock mounts, coil spring mounts, hardware and instructions.

<u>P/N</u>		
40-223-80	5" mounts & 80# springs	
40-223-95	5" mounts & 95# springs	
40-223-110	5" mounts & 110# springs	
40-223-130	5" mounts & 130# springs	
40-223-150	5" mounts & 150# springs	
40-223-170	5" mounts & 170# springs	
40-223-200	5" mounts & 200# springs	
40-223-250	5" mounts & 250# springs	
40-223L-80	7-1/2" mounts & 80# springs	
40-223L-95	7-1/2" mounts & 95# springs	
40-223L-110	7-1/2" mounts & 110# springs	
40-223L-130	7-1/2" mounts & 130# springs	
40-223L-150	7-1/2" mounts & 150# springs	
40-223L-170	7-1/2" mounts & 170# springs	
40-223L-200	7-1/2" mounts & 200# springs	
40-223L-250	7-1/2" mounts & 250# springs	
40-223-3	Replacement shock (each)	
40-223-4	Replacement spring mount (each)	



Strange Coil-Over Shocks

- Single or Double Adjustable
- Aluminum Body
- May be used alone or with optional "remote adjustable" kit
- Serial Number for Shock History
- Dyno Tested
- High Mis-Alignment Bearings



Springs
not included

We Sell ALL STRANGE Products. Please Call Us if you don't see it listed here!

P/N

- 50-006-00 Strange Aluminum - rear, double adjustable
17-1/8" extended, 11-5/8" compressed
5.88" stroke, Strange # S-5006
(12" Springs not included)
- 50-007-00 Strange Aluminum - rear, double adjustable
19-1/8" extended, 12-5/8" compressed
6.88" stroke, Strange # S-5007
(14" Springs not included)
- 50-051 Strange Aluminum - rear, single adjustable
17-1/8" extended, 11-5/8" compressed
10 rebound settings, Strange # S-5206
(12" Springs not included)
- 50-052 Strange Aluminum - front, single adjustable
12-13/16" extended, 9-1/2" compressed
10 rebound settings, Strange # S-5203
(7" Springs not included)

Strange Mustang Struts & Shocks

- 10 Performance settings • Street/Strip
- Fits OEM applications • Steel Construction
- Easily accessible external rebound (extension) adjustment
- Coil over kit for struts sold separately



P/N

- 55-S5042 05-10 Mustang Strange double adjustable rear shock (each)
- 55-S5242 05-10 Mustang Strange single adjustable rear shock (each)
- 50-S6000EM 79-93 Mustang Strange externally adjustable (10 rebound adjustments) rear shock (each)
- 50-S6001EM 87-93 V8 Mustang Strange externally adjustable (10 rebound adjustments) front strut (each)
- 50-S6001 Coil over kit for Mustang struts includes aluminum body, spring seat, jam nut & bearings (each)
- 50-S6004LM 94-2002 Mustang Strange externally adjustable (10 rebound adjustments) rear shock (each)
does not fit Cobra with independent rear
- 50-S6005LM 94-2002 Mustang Strange externally adjustable (10 rebound adjustments) front strut (each)

Honda Coil Over Drag Shocks

- Lightweight aluminum construction
- Easily accessible compression & extension adjustments
- Double adjustable
- 10" front & 12" rear Hypercoil springs - optional
Fits 89-91 CRX*, 89-01 Civic* and 94-02 Integra
(* 89-91 CRX & 89-01 Civic knuckles must be replaced with 92-01 OEM Civic knuckles)

P/N

- 50-S5015 Front coil over shock - double adjustable - each
- 50-S5016 Rear coil over shock - double adjustable - each



Strange Direct-Fit Shocks

available Single or Double Adjustable!!

- Based On the Proven Coil-Over Technology
- Lightweight Aluminum Construction
- Easily Accessible External Extension (Single Adjustable) and Compression (Double Adjustable) Tuning knobs
- Billet Steel Cross Bars "Bolt-In" Shocks
- Polyurethane Bushings
- Wide Range of Adjustments
- Ideal for Street & Track • Sold - Each



Chevrolet Direct-Fit Shocks

P/N

- 50-S5263* 67-69 Camaro, 68-83 Chevelle/Malibu
70-88 Monte Carlo, 68-79 Nova
Front Single Adjustable
- 50-S5267* 70-81 Camaro, 64-67 Chevelle
55-57 Chevy full size, 58-96 Impala
Front Single Adjustable
- 50-S5269** 93-02 Camaro
Front Single Adjustable
- 50-S5069** 93-02 Camaro
Front Double Adjustable
* Requires modification to stock a-arm
** Requires aftermarket spring
- 50-S5262 67-69 Camaro mono leaf
Rear Single Adjustable
- 50-S5062 67-69 Camaro mono leaf
Rear Double Adjustable
- 50-S5266 67-69 Camaro multi leaf
Rear Single Adjustable
- 50-S5066 67-69 Camaro multi leaf
Rear Double Adjustable
- 50-S5268 70-81 Camaro
Rear Single Adjustable
- 50-S5068 70-81 Camaro
Rear Double Adjustable
- 50-S5270 82-02 Camaro, 62-67 Chevy II
Rear Single Adjustable
- 50-S5070 82-02 Camaro, 62-67 Chevy II
Rear Double Adjustable
- 50-S5264 64-83 Chevelle/Malibu, 58-96 Impala
70-88 Monte Carlo, 68-79 Nova
Rear Single Adjustable
- 50-S5064 64-83 Chevelle/Malibu, 58-96 Impala
70-88 Monte Carlo, 68-79 Nova
Rear Double Adjustable
- 50-S5272 55-57 Chevy full size
Rear Single Adjustable
- 50-S5072 55-57 Chevy full size
Rear Double Adjustable

Dodge & Plymouth Direct-Fit Shocks

- 50-S5281 64-74 Barracuda, 70-74 Challenger,
65-72 Charger & Coronet, 62-72 Belvedere & Satellite
62-76 Dart, Swinger & Demon, 62-64 Fury
- 50-S5081 60-76 Duster, Valiant & Scamp Front Single Adjustable
64-74 Barracuda, 70-74 Challenger,
65-72 Charger & Coronet, 62-72 Belvedere & Satellite
62-76 Dart, Swinger & Demon, 62-64 Fury
- 50-S5282 60-76 Duster, Valiant & Scamp Front Double Adjustable
64-74 Barracuda, 70-74 Challenger,
65-76 Charger & Coronet, 62-72 Belvedere & Satellite
62-76 Dart, Swinger & Demon, 62-78 Fury
- 50-S5082 60-76 Duster, Valiant & Scamp Rear Single Adjustable
64-74 Barracuda, 70-74 Challenger,
65-76 Charger & Coronet, 62-72 Belvedere & Satellite
62-76 Dart, Swinger & Demon, 62-78 Fury
- 50-S5283 60-76 Duster, Valiant & Scamp Rear Double Adjustable
73-76 Charger & Coronet Front Single Adjustable
- 50-S5083 73-76 Charger & Coronet Front Double Adjustable

QA-1 Coil Over Shocks

The QA1 Coil over shock is built from billet aluminum that is clear anodized for superior durability and appearance. QA1's valving has been calibrated to meet the new found demands of today's sportsman racers. The QA1 offers external adjustment for quick corrections, even in the staging lanes, due to changing track conditions. Only the best quality components are used in every QA1 shock; 5/8" Nitro-tec piston rod equal to stainless steel for corrosion resistance and 40% harder than hard chrome, plus a multi-lip internal and external wiper seal to keep dirt out and fluid in. High quality, 1/2" spherical rod ends are included. The graduated adjuster knob offers a quick reference for your shock setting. There are a total of twelve (12) different shock settings that adjust both bump and rebound simultaneously. Every QA1 externally adjustable shock is dyno tested to assure you maximum performance.



50-019A 50-219A

P/N

NOTE: QA1 shocks do not include springs

- 50-017A QA1 - front, 11-1/4" extended, 9" compressed - uses 7" x 2-1/2" spring, recommended ride height 9-1/2" - 10" QA1 #DS301
- 50-018A QA1 - rear, 18-1/2" extended, 13-1/2" compressed uses 14" x 2-1/2" spring, recommended ride height 14-3/4" - 15-1/2", QA1 #DS601
14" Springs available by special order
- 50-019A QA1 - rear, 16-3/8" extended, 11-5/8" compressed - uses 12" x 2-1/2" spring, recommended ride height 13-1/2" - 14". QA1 #DS501
- 50-020A QA1 - rear, 14" extended, 10-1/8" compressed - uses 10" x 2-1/2" spring, recommended ride height 11-1/2" - 14". QA1 #DS401
- 50-219A QA1 - rear, Double Adjustable, 16-315/16" extended, 11-13/16" compressed - uses 12" x 2-1/2" spring, recommended ride height 13-1/2" - 14". QA1 #DD501

We Sell ALL
QA1
Products.
Please Call
Us if you
don't see it
listed here!
800
523-3353

QA-1 "F" Generation Shocks

Generation-F Front QA1 Motorsports are the best front shock available for GM F-body cars (1993 - present Camaros and Firebirds). Street, strip, or handling, these are the shocks that can do it all! The GEN-F provides machined aluminum, externally adjustable shocks designed specifically for this series chassis. Single or double adjustable shocks are available

P/N

- 50-RC-7855-P Front single adjustable shock drag race only (each)
- 50-15FB-275 275# Drag race front spring (each)
- 50-15FB-300 300# front spring - nice ride & handling (each)
- 50-15FB-325 325# front spring - firm ride & handling (each)
- 50-TS-704 Rear single adjustable shock (each)

We sell the Complete Line of QA1 Products.

Please Call Us if you don't see it listed here! 800-523-3353

QA-1 Mustang Struts

The QA1 Mustang struts are a direct replacement for the factory struts. They can be used with or without QA1 coil-over kits. For 2005 & up Mustang struts QA1 caster/camber plates are required and QA1 Coil-Over Kits are highly recommended for ease of installation. Increased sensitivity in valving response, control and consistency. Gone are the days of removing shocks and struts to adjust valving simply turn the knob. Struts are fully threaded for easy coil-over conversion. Polyurethane bushings standard in shocks. These struts and shocks are revalveable and rebuildable by QA1 Authorized Service Centers

Pro Coil Systems

QA1 Pro Coil Systems are designed to replace the stock shock and coil spring found on most GM models with a more performance designed QA-1 shock & coil spring. Available in 4 different styles, QA-1 Pro Coil Systems will fit your budget as well as your application. The four style are -

Double Adjustable System

This kit features double adjustable shocks with 576 valving options obtained thru 24 positions of compression adjustment on one knob and 24 positions of rebound adjustment on the other knob. A Threaded aluminum body offers adjustable ride height and 4 choices of spring rate are available. Available for most popular Chevy, Buick, Olds & Pontiac models.

Single Adjustable Drag Race System

This kit features single adjustable "R" series shocks with 24 valving options. This shock has a firm compression setting and the knob adjusts the extension valving. Threaded aluminum body offers adjustable ride height and 4 choices of spring rate are available. Available for most popular Chevy, Buick, Olds & Pontiac models. **Recommended for drag race use only**

Single Adjustable Street Performance System

This kit features single adjustable shocks with 24 valving options. This shock has one knob which adjusts the compression & extension valving simultaneously making it ideal for high-performance street applications. Threaded aluminum body offers adjustable ride height and 4 choices of spring rate are available. Available for most popular Chevy, Buick, Olds & Pontiac models.

Economy Pro Coil System

This kit features the economy "Stocker Star" steel non-adjustable shock. A unique aluminum sleeve over the shock allows adjustable ride height and 4 choices of spring rate are available. Available for most popular Chevy, Buick, Olds & Pontiac models.



- Double Adjustable
- Single Adjustable Drag Race
- Single Adjustable Street
- Economy Pro Coil

Please call our sales department for application & availability

QA1 Motorsports has designed a spring for the '93 - present Camaro/Firebird front suspension to be used with the QA1 Motorsports GEN-F. The GEN-F Spring is built specifically with factory and modified small block cars in mind. It is designed to sit on the GEN-F spring seat and fit into the stock mount at the top. When used in conjunction with the spring, it is unmatched in ease of installation and performance.

P/N

- 35-HD601 79-93 Front strut (each)
- 35-HD603 94-04 Front 5.0, 4.6 including Cobra (each)
- 35-HD604 05-10 Front w/o sway bar bracket(each)
- 35-HD605 05-10 Front with sway bar bracket (each)

BUMP • REBOUND • COMPRESSION • EXTENSION • What does it all mean?

TECH TIP

You'll hear racers using these words all the time when discussing their shock absorbers. Bump & compression mean the same and is when suspension travel is moving the shock in the direction SHORTER than it's installed height. Rebound or extension is when the shock is becoming LONGER. Double adjustable shocks have the ability to control these movements independently of one another, while single adjustable shocks offer only one type of adjustment. Some single adjustable shocks adjust both extension & compression simultaneously and equally while others adjust only extension which is preferable for drag race applications. For more info contact your S&W sales representative for the type of shock that is right for you.



9" FORD REARS

With over 50 years of experience in building complete rears for both drag racing & high performance street machines, S&W Race Cars can build a complete rear package that is right for you! S&W Race Cars uses only the best components in every rear we sell assuring you trouble free service & long component life.

Because of the various options for carrier type, pinion support type, ring & pinion options, spool & posi options, and pinion yoke & coupler options it is impossible to list all the possibilities here. Please call your S&W sales person for prices and more information. All 9" Ford rears are shipped without the center or axles installed



AXLE HOUSINGS

S&W has the equipment to modify any rear axle housing. All work is done using S&W's precision rear housing jig.

- Services available are:
- Narrowing rear housing
 - Replacing or realigning bearing flanges
 - Installing chrome-moly axle tubes (Ford housings only)
 - Installing C-clip eliminators
 - Installing floater kits
 - Installing brackets and back braces
 - Installing fill and drain plugs
- S&W can also supply you with a custom finished rear housing.**

P/N

- 45-002 Strange S60 (Dana) housing. No ends
- 45-020 Fabricated Econo Dragster 9" housing with Olds ends
- 45-021 Fabricated Altered 9" housing with Olds ends
- 45-023 Fabricated TA/FC 9" housing with Strange spindle ends
- 45-110 9" Ford new housing with ends. No brackets.
- 45-469 9" Ford new housing with ends and brackets to customer spec.
- 45-469B 9" Ford new housing with ends and brackets & back brace to customer spec.

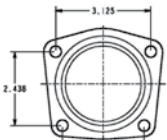

STRANGE Small GM

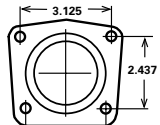

Small G.M. Camaro/Chevelle/Nova

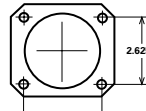

Large G.M. Impala/Blazer

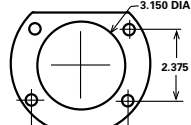

49-72 Big Bearing Ford

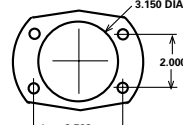

Late Model Big Bearing Ford

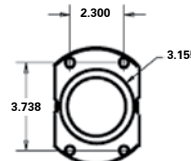

05-14 Mustang

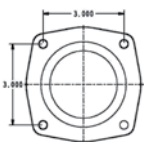

STRANGE Symmetrical

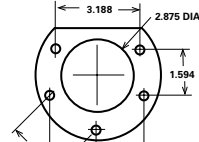

8-3/4 Mopar/Dana 60

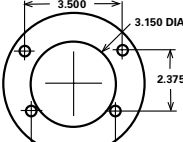

49-64 Olds/Pontiac

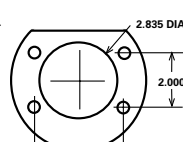

Small Bearing Ford

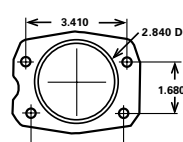

8.8 Ford

FABRICATED REAR HOUSING

S & W's new fabricated rear housing is perfect for drag race & pro/street use. The center is 17" wide with internal axle tube gussets for added strength and axle tube stability. The S&W fabricated housing fits any 9" Ford center and is offered as either a "bare" center with 3" x .188" wall axle tubes or as a finished rear to fit any of S&W's rear frame packages. S&W can also custom build one to your specific specifications or application. Bare housing will make finished rear up to 72" wide. Every housing features a filler, magnetic drain and vent.

P/N

- 45-048MS Mild Steel - bare - no ends or brackets
- 45-048CM Chrome Moly - bare - no ends or brackets
- 45-049MS Mild Steel - bare - no ends or brackets - w/back brace
- 45-049CM Chrome Moly - bare - no ends or brackets - w/back brace
- 45-050MS Mild Steel - bare - no brackets - w/housing ends
- 45-050CM Chrome Moly - bare - no brackets - w/housing ends
- 45-051MS Mild Steel - Dragster - no brackets - w/housing ends
- 45-051CM Chrome Moly - Dragster - no brackets - w/housing ends
- 45-052MS Mild Steel - w/brackets, ends & back brace
- 45-052CM Chrome Moly - w/brackets, ends & back brace



Shown with Optional Powder Coating

45-053CM



45-460 45-460S

45-460C 45-460Ji

P/N

- 45-460 9" Ford 2x3 housing back brace kit (large web housing)
- 45-460C 9" Ford 2x3 housing back brace kit (Hot Rod housing)
- 45-460S 9" Ford 2x3 housing back brace kit (small web housing)
- 45-460Ji 9" Ford 2x3 housing back brace kit (small web housing)
- 45-491MS Housing back brace kit (S&W fab housing- mild steel)
- 45-491CM Housing back brace kit (S&W fab housing- moly)

Big Web & Small Web

When searching for a 9" Ford housing for your next "do-it-yourself" project, you should be aware that Ford housings come in what are commonly referred to as "big web" & "small web" varieties. The difference is in the width of the welded center assembly that the axle tubes and center section install into. The "big web" housing, while slightly stronger, may cause installation problems and require custom fitting of ladder bar or 4-link brackets on cars with narrowed frame rails. The narrow width of the "small web" housing makes installation of these brackets much easier and usually does not require any special fitting or grinding. Unfortunately, the "small web" housing is becoming extremely rare and is more & more difficult to find - the search, however can save you hours in installation time. The easy solution is to buy your housing from S&W when you purchase your frame package or contact your S&W salesperson about a custom housing for your new project. Please refer to the photos below for a visual difference in the 9" Ford housings.

Small Web shown with Hot Rod Cover

Small Web

Big Web



S&W housing ends are made from billet steel and are precision machined to provide a flat mounting surface not always found on used ends.

P/N

- 45-012 49-64 Olds/Pontiac
- 45-013 8-3/4 Mopar & Dana 60
- 45-014 Small Ford
- 45-015 49-72 Big Ford
- 45-046 05-14 Mustang
- 45-1131 Strange Symmetrical
- 45-1137 Late model big Ford
- 45-047 8.8 Ford
- 45-1143 Strange Small G.M. uses 3.15 bearing
- 45-H1147 Mopar
- 45-5845 Large GM

TECH TIP

The housing end chart at the left shows the size and bolt pattern differences between the most commonly used housing end types. It is critical that you give us the proper housing end type when ordering to assure delivery of the correct parts. If your housing end does not match any of the ends shown here, please carefully measure your end for bearing diameter and bolt pattern as shown here and contact the S&W tech and info line for assistance when ordering axles or brakes.

9" Ford Back Braces

S&W back braces are custom cut to fit your housing with little trimming. Each brace is 40" long, made from 1/8" steel and when installed greatly increase the strength of your housing. Welding is required for installation and a housing jig is necessary to prevent tube distortion during welding.



560 Dana Style

Strange Engineering now offers their design of the Dana 60 housing. It accepts Dana 60 gear sets, differentials, and spools. The case and the extra heavy duty caps are cast from premium grade nodular iron for superior strength. Side adjuster nuts replace the troublesome carrier shims to greatly reduce setup time. The Mopar version has the mounting provision for a factory or an aftermarket pinion snubber. The G.M. A-Body or G-Body version is cast with raised upper control arm mounts to increase traction. Leaf spring mounts are available for Mopar and G.M. applications.



Complete Assemblies

P/N

- 45-PRSB05 Strange 60 housing with snubber provision (without mounts), choice of housing ends, Trac-Lok 35 spline posi unit, Standard gear set, 1350 series pinion yoke, S/T axles, bearings, retainer plates, 1/2" stud kit, and fully assembled.
(Less brakes)
- 45-PRSL05 Same as above with leaf spring mounts installed
(Mopar or G.M.)
- 45-PRSB10 Strange 60 housing with snubber provision (without mounts), choice of housing ends, 35 spline spool, Standard gear set, 1350 series pinion yoke, Pro Race axles, bearings, retainer . plates, 1/2" stud kit, and fully assembled.
(Less brakes)
- 45-PRSL10 Same as above with leaf spring mounts installed.
(Mopar or G.M.)
- 45-PRSB15 Strange 60 housing with snubber provision (without mounts),choice of 3.150 bearing housing ends, 40 spline spool, Pro gear set, 1350 series pinion yoke, Pro race solid axles, .. bearings, 5/8" stud kit, and fully assembled.
(Less brakes)
- 45-PRSL15 Same as above with leaf spring mounts installed.
(Mopar or G.M.)
- 45-PRSA05 Strange 60 G.M. A-Body coil spring housing with spring seats, choice of housing ends, Track-Loc 35 spline posi unit, Standard gear set, 1350 pinion yoke, S/T axles, bearings, ... retainer plates, 1/2" stud kit, and fully assembled.
(Less brakes)
- 45-PRSA10 Strange 60 G.M. A-Body coil spring housing with spring seats, choice of housing ends, 35 spline spool, Standard gear set, 1350 series pinion yoke, Pro Race axles, bearings, retainer . plates, 1/2" stud kit, and fully assembled.
(Less brakes)
- 45-PRSA15 Strange 60 G.M. A-Body coil spring housing with spring seats, choice of 3.150" housing ends, 40 spline spool, Pro gear set, 1350 series pinion yoke, Pro Race solid axles, bearings, 5/8" stud kit, and fully assembled.
(Less brakes)
- 45-PRSG05 Strange 60 G.M. G-Body coil spring housing with springs .. seats, choice of housing ends, 35 spline Trac-Lok posi unit, Standard gear set, 1350 series pinion yoke, S/T axles, bearings, retainer plates, 1/2" stud kit, fully assembled.
(Less brakes)
- 45-PRSG10 Strange 60 G.M. G-Body coil spring housing with spring seats, choice of housing ends, 35 spline spool, Standard gear set, 1350 series pinion yoke, Pro race axles, bearings, retainer .. plates, 1/2" stud kit, fully assembled.
(Less brakes)
- 45-PRSG15 Strange 60 G.M. G-Body coil spring housing with spring seats, choice of 3.150" housing ends, 40 spline spool, Pro gear set, 1350 series pinion yoke, Pro Race solid axles, bearings, 5/8" stud kit, and fully assembled.
(Less Brakes)

79-98 Mustang Bolt In 9" Ford Housing (STRANGE or MOSER)

Direct bolt in, complete 9" Ford rear for 79-98 Mustang. Due to the many options and variables available when ordering one of these complete rears, please contact an S&W sales representative for more details

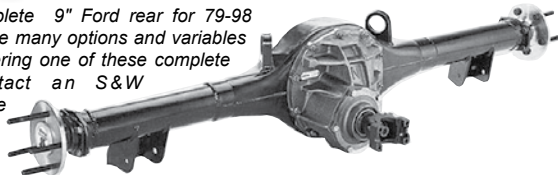

GM Direct Fit Bolt-In 9" Housings (STRANGE or MOSER)

P/N

- G.M. G-Body
- G.M. A-Body
- G.M. Mono-Leaf & Multi-Leaf
- 1959-1964 Full Size Chevy
- 1955-1957 Chevy
- 1982-1997 S10 Pick Up & 1965-1970 Chevy impala

82-02 Camaro and Firebird Bolt In 12 Bolt Housing

Housing designed w/ torque arm provision. New Strange designed case w/ fully welded tubes, chrome moly caps NO c-clips necessary. Accepts 93-97 disc or drum brakes. Optional ABS sensor



P/N

- 45-PRG200 Fully assembled bolt in rear end 1982 -1992 less brakes includes 3.150" ID housing ends, 33 spline Torqueline posi, S/S axle package, 1/2" or M12 studs, US Strange standard gear set, "S" series yoke, crossover u-joint, chrome cover
- 45-PRG210 Fully assembled bolt in rear end 1993-2002 less brakes includes 3.150" ID housing ends, 33 spline Torqueline posi, Choice of 3 channel (center) or 4 channel (axle) ABS, Choice of caliper mounts (93-97 or 98-02) S/S axle package, 1/2" or M12 studs, US Strange standard gear set, "S" series yoke, crossover u-joint, chrome cover
- 45-PRG220 12 bolt rear housing only 1982 -1992 or 1993-2002 includes 3.150" ID housing ends, 33 spline S/S axle package, 1/2" or M12 studs
- 45-PRG230 Fully assembled bolt in DRAG RACE rear end 1982 -2002- less brakes, 3.150" ID housing ends, 33 spline light weight spool, 1350 Yoke, US Strange pro gear , 33 spline Pro Race axles, 1/2" or M12 studs, chrome cover

82-02 Camaro and Firebird Bolt In S-60 Housing

Modular iron casting • Torque arm provision.
Fully welded tubes • Far superior to any 12 bolt.
Fully machined for factory ABS sensor

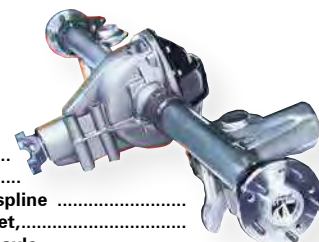

P/N

- 45-PRSF05 Strange 60 G.M. F-Body coil spring housing with spring & torque arm mounts, 35 spline Heavy duty posi unit, Standard gear set, 1350 series pinion yoke, 35 spline S/T axle bearings, retainer plates, 1/2" stud kit, fully assembled (Less brakes)
- 45-PRSF10 Strange 60 G.M. F-Body coil spring housing with spring & .. torque arm mounts, 35 spline spool, Standard gear set, 1350 series pinion yoke, 35 spline Pro Race axles, bearings, retainer plates, 1/2" stud kit, fully assembled (Less brakes)
- 45-PRSF15 Strange 60 G.M. F-Body coil spring housing with spring & .. torque arm mounts, 40 spline spool, Standard gear set, 1350 series pinion yoke, 40 spline Pro Race axles, bearings, retainer plates, 1/2" stud kit, fully assembled (Less brakes)

Options for Rear Assemblies

P/N

Description		add	CALL
5/8" stud kit		add	CALL
Pro gear		add	CALL
H.D. Alum. cover		add	CALL
Gun-drilled axles.....		add	CALL
Ultra Light flanges.....		add	CALL
11" Drum Brake Kit installed.....		add	CALL
SVO Disc Brake Kit installed.....		add	CALL
Drag Race Only:			
S-Series Disc Brake Kit installed		add	CALL
Pro Series Disc Brake Kit installed		add	CALL

Strange prices do not include shipping from Strange

REAR AXLE COMPONENTS

■ Axles - Please Call For Current Pricing

S&W offers Strange Engineering "Hy-Tuff" & Moser thru-hardened axles in 30, 31, 33, and 35 spline. Forty spline axles available by special order. Axles are available for any length housing, bearing end, brake type or bolt circle. Race Axles are machined from aircraft quality nickel alloy forgings and heat treated to meet the special requirements of high-torque racing applications. Mfg. Factory Warranties avail. on all axles. S&W can also supply you with Mark Williams' "Hi-Torque" drag race axles.



Determining Axle Length

S&W's in-house computer features an exclusive axle program to aid in calculating the proper axle lengths for your rear housing. In order to determine the axle lengths for your application it is important that you provide us with accurate measurements and that both you and our salesmen use the same terminology when referring to those measurements.

The following information is required for all axle orders.

- Type of housing (9" Ford, 12 bolt Chevy, Dana - etc.) • Type of housing end (refer to page 40 for chart)
- Spool or posi unit (number of splines) • Pinion offset • Bolt circle diameter • Brake type (disc or drum)
- Measurement from housing end to housing end and measurement from axle flange to axle flange • Stud size

Call Your S&W Representative
for Assistance 1-800-523-3353

Axles 30, 31, 33 or 35 spline
Race Axles with bearings & 1/2" studs
as above with 5/8" studs (Strange)

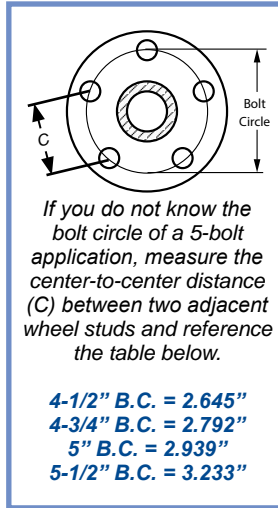
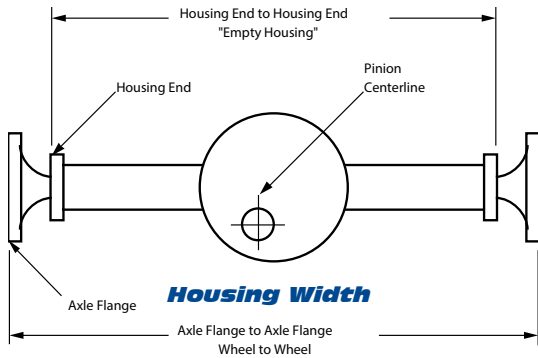

Axles 40 spline

Race Axles with bearings & 5/8" studs

- Solid axles
 - 1 bolt circle
 - (5) 1" lightening holes in axle flange
- Gun drilled axles
 - 1 bolt circle
 - (5) 1" lightening holes in axle flange

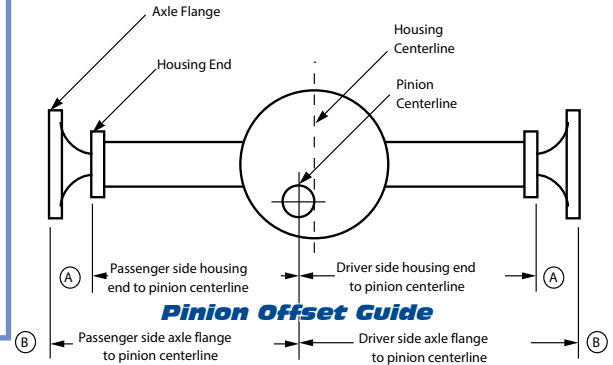

■ Strange • S/S Street & S/T Series Axles

Strange Engineering has introduced the finest induction hardened axle on the aftermarket - Strange S/S Street & S/T Series. S/S axles are designed for the street enthusiast that desires a quality axle at an economical price. S/S axles are available in Ford 31 spline for the Ford 9" and for the Ford 8.8" housings. The S/T series axle's 35 tooth involute spline and 1.500" shaft diameter permit this axle to be used for Pro/Street & selected drag race applications. The induction hardening process allows for an axle with a soft core and a hard surface - this is the ideal heat treatment for the bending loads encountered with street use. How do the S/S & S/T Series axles compare to those "Custom Alloy Race Axles" we see advertised for \$295.00? **S/S & S/T Axles are stronger!!**

The major differences are: As with every Strange axle involute splines are hobbled BEFORE heat treatment - not cut into an already hardened axle. The involute splines provide an extremely fatigue resistance axle. Also, Strange precision machines the bearing shoulder to accept a radii ring which minimizes stress concentrations in the bearing area. Billet aluminum brake registers are provided to assure your factory disc or drum fits correctly. These induction hardened axles are accepted by the NHRA & IHRA; However Strange Engineering strongly recommends their THRU-HARDENED AXLES for hard core drag racing.



- **S/S Street**.....
- with bearings & 1/2" studs **CALL**
- with bearings & 5/8" studs **CALL**



- **S/T Series**.....
- with bearings & 1/2" studs **CALL**
- with bearings & 5/8" studs **CALL**

■ Pinion Center Locators

Measuring your Ford or Dana housing has never been easier! S&W Race Cars, pinion center locating plate has been a secret of chassis builders for years. Place the end of your tape measure in the slot and you can measure your housing and pinion offset without guesswork. This tool is a must for the well equipped toolbox.

P/N	
95-019	Ford - 9"
95-023	Ford - 8"
95-024	Dana 60
95-028	GM 12 Bolt
95-029	Ford 8.8
95-033	8-3/4" Mopar

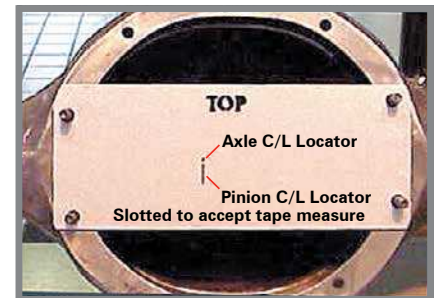

■ Aluminum Support Covers

LPW Ultra-Pro covers are available for popular applications and is the lightest weight support cover on the market. LPW Ultimate Covers are the only covers offering the ability to add an Axle-Tube Brace for unsurpassed rear-housing strength and stiffness. LPW support covers aid in maintaining proper pinion depth and gear backlash, resulting in maximum gear life and performance. Additional clearance for billet main caps and low gear ratios is provided along with increased fluid capacity. A magnetic drain plug is incorporated to attract metal flakes and other debris that may cause additional problems and potential damage within the housing. Adjustable grade 8 load bolts are included to hold the bearing main caps firmly in place, delivering greater protection against movement and eventual cap breakage.

- | P/N | |
|-------------|--|
| 45-201-10 | GM 10 bolt (8.2" / 8.5") aluminum Ultra support cover |
| 45-301-10 | GM 10 bolt (8.2" / 8.5") aluminum Ultimate support cover (ready for brace) |
| 45-201-12 | GM 12 bolt (passenger car) aluminum Ultra support cover |
| 45-301-12 | GM 12 bolt (passenger car) aluminum Ultimate support cover (ready for brace) |
| 45-301-7.5G | GM 10 bolt (7.5" / 7.625") aluminum Ultimate support cover (ready for brace) |
| 45-201-61 | 81 to present 8.8 Ford aluminum Ultra support cover (does not fit Cobra IRS) |



Ultra



Ultimate



Axle Bearings & Retainers

S&W stocks a complete line of axle bearings and retainers for all popular axle sizes and housing ends.

P/N

- 45-131 Strange small G.M. bearing retainer plate
- 45-132 Late model big Ford bearing retainer plate
- 45-133 Olds bearing retainer plate
- 45-134 Big Ford bearing retainer plate (49-72)
- 45-1013 Tapered axle bearing w/seal - 3.150" end, 1.52" bore
- 45A-1013C Replacement seal for 45-1013 bearing
- 45-1018 Replacement o-ring for 3.150" bearing
- 45-1019 Axle bearing - 3.150" end, 1.772" bore
- 45-1020 Axle bearing - 3.150" end, 1.531" bore
- 45-1021 Axle bearing - 3.150" end, 1.563" bore
- 45-1022 Axle bearing - Mopar nonadjustable with retainer plate, Snap Ring
- 45-1022OB Axle Bearing - Mopar nonadjustable with removable retainer and bearing locator for use with Strange or Wilwood drag race disc brakes
- 45-1023 Axle bearing - Small Ford, 2.835" end, 1.563" bore with retainer plate
- 45-1370 Bearing retainer ring - 1.370" bore
- 45-1390 Bearing retainer ring - 1.390" bore
- 45-1525 Bearing retainer ring - 1.525" bore
- 45-1560 Bearing retainer ring - 1.560" bore



45-1022 45-1022B 45-1023 45-1021 45-1013

C-Clip Eliminator Kits

These kits are designed to eliminate the dangerous factory C-clip on Chevrolet 12-bolts and provide a safety hub with sealed, press-on bearings. These kits are required for use with Strange 12-bolt axles. Kits are also available for stock, factory type axles. Sold in pairs.

P/N

- 45-030 For Strange axles on Camaros, Novas, and Chevelles
- 45-031 For Strange axles with big bearings on Impalas & Blazers
- 45-032 For Stock axles on Camaros, Novas, & Chevelles
- 45-033 Seals (each)
- 45-034 Gaskets (each, fits 45-030 & 45-032 only)

Ford 9" Center Sections & Components

S&W stocks a complete selection of 9" Moser & Strange Ford centers and assembly parts.

P/N

- 45-H1112G Ford 9" gasket
- 45-N2205 Strange S-Series Nodular Center, 3.062" brg. with nodular caps & adjusters
- 45-N2206 Strange S-Series Nodular Center, 3.250" brg. with nodular caps & adjusters
- 45-402 Strange Alum. Center, 3.062" brg with steel caps & adjusters
- 45-403 Strange Alum. Center, 3.250" brg with steel caps & adjusters
- 45-405 Strange Nodular Center, 3.062" brg with steel caps & adjusters
- 45-406 Strange Nodular Center, 3.250" brg with steel caps & adjusters
- 45-412 Mark Williams Alum. Center, 3.250" brg with alum. caps & billet steel adjusters
- 45-P3250LT Strange Thru-Bolt Ultra Case, Package
- 45-415 Pinion nut for 35-spline oversize pinion
- 45-416 Carrier studs and nuts (set of 10)
- 45-421 Pinion support shim kit for stock pinion support
- 45-423 Pinion nut for 28-spline standard pinion
- 45-425 Strange Aluminum pinion support
- 45-426 Bearings, shims & seals for 45-425 with 28-spline pinion
- 45-427 Bearings, shims & seals for 45-425 with 35-spline pinion
- CALL Complete Nodular Center with spool, ring & pinion & yoke or coupler
- CALL Complete Aluminum Center with spool, ring & pinion & yoke or coupler
- 45-605 9" Ford tail bearing & lock

****S&W can also supply you with a fully assembled center section. Call for Info.****



Strange or Moser? Tell your Sales Rep. when placing your order!

Spools & Spool Bearing Sets

S&W carries lightweight, forged steel spools to replace weaker, stock differential units. Using a spool increases the strength and dependability of your third member and ensures that both axles are locked together and receiving equal torque. For the Pro/Streeter S&W now stocks 9" Ford "Detroit Lockers" in 31 & 35 spline. S&W spool bearing sets include the bearings and races necessary for the installation of all Strange & Moser lightweight spools.

Sold only in sets.



P/N

- 45-239 Ford 31 spline "Detroit Locker"
- 45-240 Ford 35 spline "Detroit Locker"
- 45-241 Dana 60 35 spline "Trac Lok" 5 series
- 45-246 Ford 9" 31-spline mini-spool
- 45-247 Dana 35-spline 4.10 and down
- 45-248 Dana 35-spline 4.56 and up
- 45-249 12-bolt Chevy 33-spline
- 45-250 Olds 35-spline - uses special bearings
- 45-251 12-bolt Chevy 30-spline
- 45-253 Ford 31-spline
- 45-254 Ford 33-spline
- 45-255 Ford 35-spline - requires 3.25 case
- 45-257 Mopar 8-3/4" 35-spline
- 45-258 Ford Billet aluminum

P/N

- 45-280 Spool bearing set - Dana 60
- 45-282 Spool bearing set - 12-bolt Chevy & 63-80 Corvette
- 45-284 Spool bearing set - 57-64 Olds and 8-3/4" Mopar
- 45-286 Spool bearing set - 9" Ford - 2.891 case
- 45-288 Spool bearing set - 9" Ford - 3.062 case
- 45-290 Spool bearing set - 9" Ford - 3.250 case

Wheel Studs

S&W stocks a complete selection of Strange 1/2" & 5/8" drive studs. All studs are sold in packs of 10



P/N

- 45-144 1/2" x 3" axle studs
- 45-145 5/8" x 3" axle studs
- 45-1037 5/8" x 2.062" axle studs
- 45-1039 5/8" x 2.688" axle studs
- 45-144-2 Washer for 1/2" axle studs

9" Ford Carrier Studs

Sold in packs of 10

P/N

- 45-416 Carrier studs & nuts



45-030

45-425



45-N2206

45-403

45-406



45-P3250LT



Front Drag Kits

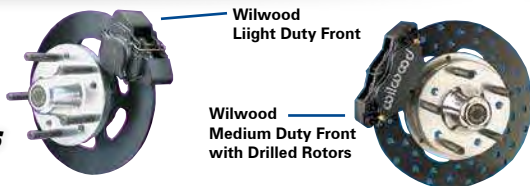

Wilwood Light Duty Front
Wilwood Medium Duty Front with Drilled Rotors

P/N

- 55-733 Heavy duty Camaro/Nova/Chevelle
- 55-727D Light weight 71-78 Pinto/Mustang
- 55-728D Medium weight 71-78 Pinto/Mustang II, drilled
- 55-730D Medium weight 67-72 Camaro drum spindle, drilled
- 55-736 Light weight P&S spindle drilled rotors
- 55-741D Medium weight 87-93 Mustang, drilled
- 55-744D Medium weight 79-87 GM "G" body, drilled

Rear Drag Kits

P/N

- 55-605D 49-64 Olds ends, drilled rotors
- 55-606D 65-73 Mopar ends, drilled rotors (snap ring brg)
- 55-607D 49-72 Ford big bearing ends, drilled. 2.36" offset
- 55-608D late model Ford big bearing ends, drilled
- 55-610D 65-73 Mustang ends, drilled, small ford ends
- 55-611D 67-77 Camaro ends, Chevy 12-bolt, drilled rotors (for use with Strange c-clip eliminator)
- 55-612D 67-77 Camaro ends, Chevy 12-bolt, drilled rotors (fits with c-clip style axles only)
- 55-622D Chevy 12-bolt with 3.150 bearing ends
- 55-655D 49-64 Olds ends, drilled rotors for 5/8" wheel studs
- 55-656D 49-64 Olds ends, drilled rotors dual calipers, for 5/8" wheel studs
- 55-746D 49-72 Ford big bearing ends, drilled. 2.50" offset



Pro/Street Brake Kits

Pro/Street kits are the ultimate in lightweight stopping power. Often the entire replacement kit weighs less than the old brake drum alone. All kits are "Bolt On" and come complete with calipers, pads, hats, vented rotors, brackets, shims and all bolts. Rear kits are available with or without parking brake and are for 15" and larger wheel diameters only. Front kits feature all the same components used in rear kits plus high-tech machined aluminum hubs.

Please call for part numbers and information concerning Pro/Street front brake kits not list below.



P/N

- 55-613 Rear brake kit for late model big Ford ends
- 55-613D Rear brake kit for late model big Ford ends w/ drilled rotors
- 55-614 Rear brake kit for Mopar ends
- 55-615 Rear brake kit for 57-64 Olds ends
- 55-616 Rear brake kit for 49-72 big Ford ends
- 55-616D Rear brake kit for 49-72 big Ford ends w/ drilled rotors
- 55-617 Rear brake kit for small Ford ends
- 55-618 Rear brake kit for 12-bolt Chevy ends (will not fit with c-clip elim.)
- 55-642 Rear brake kit for small GM 3.150 brg. end
- 55-623 Rear brake kit for late model big Ford ends w/parking brake
- 55-623D Rear brake kit for late model big Ford ends w/parking brake w/drilled rotors
- 55-624 Rear brake kit for Mopar ends w/parking brake
- 55-625 Rear brake kit for 57-64 Olds ends w/parking brake
- 55-626 Rear brake kit for 49-72 big Ford ends w/parking brake
- 55-627 Rear brake kit for small Ford ends w/parking brake
- 55-628 Rear brake kit for 12-bolt Chev. ends w/parking brake will not fit with c-clip eliminator
- 55-777 Low Profile Disc Rear Brake Kit with Parking Brake for new style Big Ford Ends, 3.19" Diam, 11" Rotors
- 55-726 Front brake kit for 71-78 Pinto
- 55-733D Front brake kit drilled. Chevelle, Nova, Camaro + many other GM. Call for list.
- 55-734 Front brake kit for 79-87 GM "G" body
- 55-742 Rear brake kit for small GM 3.150 brg. end w/drum parking brake

Big Brake Kits

Optional Red Calipers (Shown)



SL6 & W6A forged billet six-piston calipers with 13-14 rotors deliver the ultimate combination for braking power and style in this group of kits engineered for traditional non-ABS spindles on American muscle cars and vintage rods. Built exclusively for 17 and larger wheels, SL6 kits enhance tire and suspension upgrades on all types of custom show and high performance dual-purpose street and track machines. A full range of options for caliper finishes and rotor designs are guaranteed to catch the eye of the most discriminating enthusiast while providing optimized brake performance for every individual application. SL6 kits feature 13" diameter rotors while W6A kits utilize 14" diameter rotors. Standard kits have drilled & slotted rotors and black powdercoated calipers. Polished or red calipers are available at extra cost.

P/N

- 55-9803D Superlite 6R Big Brake front kit - 67-72 Camaro 12.88" dia. drilled & slotted rotors, 6 piston caliper requires 17" diameter wheels
- 55-10492D Superlite 6R Big Brake front kit - 79-81 Camaro 12.88" dia. drilled & slotted rotors, 6 piston caliper requires 17" diameter wheels
- 55-6743D Superlite 6R Big Brake front kit - 93-97 Camaro 12.88" dia. drilled & slotted rotors, 6 piston caliper requires 17" diameter wheels
- 55-11269D W6A Big Brake front kit - 2010-2011 Camaro 14.25" dia. drilled & slotted rotors, 6 piston caliper requires 18" diameter wheels

P/N

- 55-10220D Superlite 6R Big Brake front kit - 70-73 Mustang 12.88" dia. drilled & slotted rotors, 6 piston caliper requires 17" diameter wheels
- 55-9801D Superlite 6R Big Brake front kit - 74-78 Mustang II 12.88" dia. drilled & slotted rotors, 6 piston caliper requires 17" diameter wheels
- 55-9107D Superlite 6R Big Brake front kit - 94-04 Mustang 12.88" dia. drilled & slotted rotors, 6 piston caliper requires 17" diameter wheels
- 55-9109D Superlite 6R Big Brake front kit - 05 Mustang 12.88" dia. drilled & slotted rotors, 6 piston caliper requires 17" diameter wheels
- 55-10830D W6A Big Brake front kit - 05 Mustang 14.25" dia. drilled & slotted rotors, 6 piston caliper requires 18" diameter wheels



Wilwood Rear Drag Kits with Drilled Rotors
Single Caliper



55-613 Pro/Street Rear Brake Kit



55-726 Pro/Street Pinto Front Brake Kit



NHRA Approved!
Dual Caliper Kits

Note! Installation of Pro/Street rear brakes with parking brake normally requires access holes on the axle flange. Please plan ahead when ordering your axles as it is impossible to add this option after the axles are hardened!

Strange & Moser Rear Drum Brake Kits

Strange 11" drum brake kits are perfect for the racer or pro/street builder on a budget. Everything you need - all new parts.



P/N

- 55-B1606 Late model big Ford ends
- 55-B1608 49-72 Big Ford ends



Strange



Front Drag Kits

P/N

- 55-700 49-64 Olds ends, slotted rotors
- 55-700D 49-64 Olds ends, dual calipers, slotted rotors
- 55-704 65-73 Mopar ends, slotted rotors includes special axle bearings
- 55-708 49-72 Ford big bearing ends, slotted rotors
- 55-712 65-73 Ford small bearing ends, slotted rotors
- 55-713 SVO / Ford rear disc brake kit for late model Ford big bearing ends, w/pkg. brake, 16" wheels
- 55-716 67-77 12 bolt Chevy small bearing ends, slotted rotors (fits with or without c-clip elim.)
- 55-750 Strange "S" Series rear brake kit 49-64 Olds ends
- 55-754 Strange "S" Series rear brake kit Mopar ends
- 55-758 Strange "S" Series rear brake kit 49-72 Big Ford ends
- 55-797 Late Model Ford big bearing ends, slotted rotors, soft pads



- 55-C17004WC Strange Pro Race Carbon rear brake kit 11" rotors, 4.75 bolt circle 49-64 Olds ends
- 55-C1200WC Strange Pro Race Carbon rear brake kit 11" rotors, 5.50 bolt circle Strange floater
- 55-799 Pro Series Rear Steel Brake Kit Early Big Ford Ends 2.332" / 35lbs.
- 55-800M Pro Series Rear Steel Brake Kit Early Big Ford Ends 2.332" / 35lbs / Metallic Pads
- 55-801 Dual Caliper Brake Kit Early Big Ford Ends 2.332"
- 55-802M Dual Caliper Brake Kit Early Big Ford Ends 2.332" / Metallic Pads
- 55-797M Pro Series Rear Steel Brake Kit Late Big Ford Ends 2.50" / Metallic Pads
- 55-804 Dual Caliper Brake Kit Late Big Ford Ends 2.50"
- 55-807M Dual Caliper Brake Kit Late Big Ford Ends 2.50" / Metallic Pads
- 55-703M Stainless Steel Brake Kit Olds Ends / Metallic Pads
- 55-809M Stainless Steel Brake Kit Late Big Ford Ends / Metallic Pads
- 55-810M Stainless Steel Brake Kit Early Big Ford Ends / Metallic Pads

Strange



Front Drag Kits

NOTE: Strange Pro Carbon front brake kits available. Please call for price & info

P/N

- 55-761 4 piston - 79-81 Camaro
- 55-762 4 piston - 79-86 Mustang, Fairmont - 4-1/2" bolt circle
- 55-765 4 piston - 67-69 Camaro, 64-74 Nova, 64-72 Chevelle
- 55-767 4 piston - 70-78 Camaro, 73-77 Chevelle, 75-78 Nova
- 55-769 4 piston - 67-71 Mopar A-Body with 9" drum spindles
- 55-771 4 piston - 67-69 Mustang drum spindle
- 55-773 4 piston - Pinto drum spindle
- 55-775 4 piston - 79-86 Mustang, Fairmont - 4-3/4" bolt circle
- 55-780 4 piston - 71-73 Pinto disc spindle
- 55-781 4 piston - 74-78 Pinto, Fairmont disc spindle
- 55-794 4 piston - 82-92 Camaro, Firebird

Front Drag Kits (continued)

P/N

- 55-767 73-77 Buick Centry / 75-77 Skylark
- 79-87 Grand National / 79-87 Regal / 73-77 Chevelle
- 55-815 65-72 Barracuda (replacement for Drums) / 65-72 Dart 65-72 Duster
- 55-765 67-72 Chevelle / 67-74 Nova / 70-72 Monte Carlo
- 55-816 70-72 Barracuda / 70 Belvedere 70-71 GTX / 70-72 Charger
- 55-813 79-87 Buick Regal / 79-87 Malibu / 79-87 Monte Carlo
- 55-771 66-69 Fairlane / 66-69 Falcon / 67-69 Ranchero 66-69 Comet / 67-69 Cougar
- 55-814 66-69 Dodge Coronet / 66-69 Plymouth Belvedere 62-64 Plymouth / 68-69 Roadrunner & GTX 66-69 Charger
- 55-775 81-83 Fairmont / 87-93 Mustang / 82-88 Thunderbird
- 55-819 42-48 Ford
- 55-762 87-93 Mustang / 82-88 Thunderbird



MOSER & AEROSPACE
Disc Brakes Available

Attention Mopar Housing Users

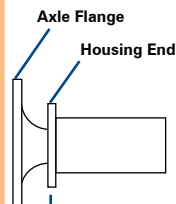

One of the most popular brand of rear axle housings also causes one of the most common brake & axle problems. If you are using an 8-3/4" or Dana housing with Mopar housing ends we must ask you to supply the dimension from housing end to outside axle face as shown on the drawing at the left. Over the years the factory has varied this measurement several times. When ordering axles for use with your factory drum brakes this measurement assures you that the axles you receive will allow your factory brake

drum to seat in the proper location with the brake backing plate. When ordering disc brakes this measurement assures you that the rotor to caliper bracket distances will be correct. When ordering replacement axles, simply measure the distance with your stock axles before ordering your new Strange axles. When ordering Strange or Wilwood disc brakes measure this distance with the axles you are using and give it to our salesperson when you place your order.



Brake Calipers

S&W stocks all the popular Strange & Wilwood drag race disc brake calipers. These calipers feature aluminum bodies with stainless steel pistons. Sold separately, less pads. Rebuild O-rings sold in sets of 4.

- P/N**
- 55-317 Wilwood Dynalite single - 3.25 mount
 - 55-318 Wilwood Forged Dynalite - for drag race rotor
 - 55-319 Wilwood Billet spot
 - 55-320 Wilwood Dynalite - for pro/street rotor
 - 55-382A Wilwood "O"-rings only - all - 1.75"
 - 55-355L Strange 4 piston - left (Black)
 - 55-355R Strange 4 piston - right (Black)

S & W stocks a complete line of caliper pistons, crossover tubes, bleeders & hardware. For all your brake rebuild needs, make your first call S & W Race Cars!



55-319

55-317

55-318

55-355

Brake Pads

Proper selection of brake pads is a critical part of high performance disc brake systems. S&W brake pads are specifically manufactured for racing applications. It's important to analyze your car's braking requirements and to select brake pads which will satisfy those requirements. All Wilwood pads are sold in boxes of 4 pads.

- P/N**
- 55-329 Strange organic for Strange 4 piston caliper (ea)
 - 55-709 Strange front brake pad for 2 piston caliper (ea)
 - 55-710 Strange metallic for Strange 4 piston caliper (ea)
 - 55-711 Strange metallic for Wilwood 4 piston caliper (ea)
 - 55-81130 Ferodo 4 piston brake pad (each)
 - 55-1251K Wilwood round spot caliper - Wilwood (set of 4)
 - 55-9764K Wilwood or JFZ 2 piston caliper
Wilwood "Low Dust Street Pad" (set of 4)
 - 55-3991K Wilwood 4 piston caliper
Wilwood "Polymatrix Pad" (set of 4)
 - 55-8850K Wilwood or JFZ 4 piston caliper
Wilwood "Smart Pad" (set of 4)
 - 55-6096K Wilwood or JFZ 4 piston caliper
Wilwood "High Temp Race Pad (set of 4)
 - 55-9820K Wilwood or JFZ 2 piston caliper
Wilwood "High Temp Race Pad (set of 4)
 - 55-3394 Strange 4 piston caliper
Wilwood "Polymatrix" (set of 4)
 - 55-9835K Wilwood or JFZ 4 piston caliper
Wilwood "Polymatrix" (set of 4)
 - 55-ACDR97 Aerospace 4 piston rear (set of 4)
 - 55-ACHPPL Aerospace 4 piston front (set of 4)



55-711

55-710

55-8850K

55-3394

55-1251K 55-9764K

55-81130

55-ACDR97

55-ACHPPL

Wilwood E-Brake Cable Kit

WILWOOD EMERGENCY BRAKE CABLE KIT (#330-9371)

- P/N** 55-513 E-Brake Cable Kit



Roll Control (Line Lock) Valves

When installed in-line with the vehicle's front brakes, the roll control allows you to do a burnout like the professionals. Simply pump up the brake, apply the roll control and release the brake pedal. The roll control keeps the front brakes applied. If you did not pump up enough brake pressure - no problem - just hit the brake pedal and the unique one-way valve puts additional pressure through to the wheel cylinder side.

- P/N**
- 95-943 Roll Control Valve

95-943



Master Cylinders

55-352



- P/N**
- 55-3359 Strange Dual in-line, Mopar style - 1-1/8" bore
 - 55-3360 Strange Dual in-line, Mopar style - 1-1/32" bore
 - 15-353 Master cylinder adapter for wilwood pedal
 - 55-352 Wilwood High Volume aluminum - 7/8" single
 - 55-353 Wilwood High Volume aluminum - 1" single
 - 55-360 Strange Dual Remote Funny Car
 - 55-364 Wilwood 1" single (plastic tank)
 - 55-365 Wilwood 7/8" single (plastic tank)
 - 55-8555 Wilwood Alum. dual - 1" bore
 - 55-8555P Wilwood Alum. dual - bright finish - 1" bore
 - 55-8556 Wilwood Alum. Tandem Chamber - 1-1/8" bore
 - 55-381 Wilwood Alum. Tandem w/pushrod - 15/16" bore



- 55-3360**
Use adapter # 15-353 to adapt Mopar style master cylinders to pedal # 15-354 shown at right



55-8555P

55-364



55-360

shown installed on Wilwood Pedal 15-354 (not included)

Master Cylinder Rebuild Kits

If a spare master cylinder is not in your racing budget, why not carry a rebuild kit for the one in your car?

- P/N**
- 55-364RK For Wilwood 55-364 - 1" bore
 - 55-365RK For Wilwood 55-365 - 7/8" bore
 - 55-366RK For Wilwood 55-353 - 1" bore

Brake Proportioning Valve

Wilwood's billet aluminum brake proportioning valve is ideal for cars with mismatched front and rear tire sizes or brake types or any brake system used in a high-performance application. Lightweight and small in size, this valve can be easily mounted in any position. Features 1/8" female N.P.T. inlet and outlet thread size.



- P/N**
- 55-368 Billet Proportioning Valve

Brake Line Quick Disconnect

S&W brake line disconnect quickly disconnects and seals the brake line to allow the removal and reinstallation of the rear axle housing without the hassle and time involved to bleed the brakes. Both halves feature 1/8" female N.P.T. thread size.



- P/N**
- 94-601 Female
 - 94-602 Male

Brake Pressure Check Gauge

Wilwood's brake pressure check gauge is essential for any racer with disc brakes. Incorrect caliper pressures will lead to rotor distortion and severely shorten brake pad life. 0-1500 psi easy to read gauge installs in bleeder fitting during testing.



- P/N**
- 94-386 Caliper Pressure Gauge

Residual Pressure Valves

Available in 2-lb. or 10-lb. settings. S&W residual pressure valves are designed as an aid to your brake system when your master cylinders are mounted lower than the disc brake calipers. This keeps brake fluid from draining back into the master cylinder reservoirs which causes the caliper's pistons to return fully into the housing. The 2-lb. residual pressure valve is intended for use with disc brake systems while the 10-lb. residual pressure valve is designed to be used only with drum brakes.



- P/N**
- 55-369 2-lb. in-line mount
 - 55-370 10-lb. in-line mount

Wilwood Brake Fluid

Don't put inferior brake fluid in your new brake system. Wilwood, hi-temp brake fluid exceeds all DOT 3 standards and has a 570 degree dry boiling point. Sold in 12 oz. bottles



- P/N**
- 55-367 Wilwood Brake Fluid

PEDAL ASSEMBLIES

Pedal Assemblies for Pro Stock & Super Gas

Designed for full bodied race cars, S&W pro pedals look as good as they work. All pedal ratios have been figured to provide the correct pedal geometry without binding or over-centering the linkage. All pedals are available in either a black powder coat finish or plated with a two step nickel/chrome finish that will withstand constant abuse, while still maintaining a quality appearance. Replaceable rubber nonskid pads are included in every pedal kit.

P/N

- 15-025B Clutch and Brake pedal kit - black
- 15-026B Brake Pedal kit - black
- 15-027B Clutch Pedal kit - black
- 15-028B Throttle Pedal kit - black
- 15-040 Throttle Pedal Return (Toe loop) bolt-on

Throttle Pedal Mounting Kit

Kit includes all tubing & hardware necessary to mount the throttle pedal to the dash crossmember of your roll cage. Includes adjustable stop. Use with 15-028 or 15-028B throttle pedal. Requires welding for installation.

P/N

- 15-044 Pedal mount kit

15-044



15-025

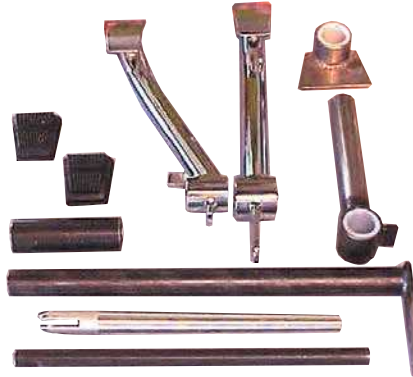

15-028



15-040B shown installed on 15-028B gas pedal

15-040

Pedal Ratio Explained

TECH TIP

Pedal assembly ratio, or mechanical leverage is the ratio calculated from the length from the pivot point of the pedal to the center of the foot pedal (A), divided by the length from the pivot point to the master cylinder pushrod (B). Refer to the figures below. Mechanical leverage is simply a means of increasing the brake force without increasing your leg effort. As A gets longer and B gets shorter, the mechanical leverage increases brake force without pushing harder on the pedal. The disadvantage is that the pedal stroke also increases, requiring you to push the pedal further. With a 1 master cylinder stroke, a 100-pound push on the pedal, and the pedal having a 4:1 ratio, the force is $4 \times 100 = 400$ pounds, and the stroke is $4 \times 1 = 4$ inches. With a 100 pound push on the pedal, and the pedal having a 6:1 ratio, the force is $6 \times 100 = 600$ pounds, and the stroke is $6 \times 1 = 6$ inches. If uncertain about which pedal ratio is right for your application, a 6:1 ratio is an excellent starting point.

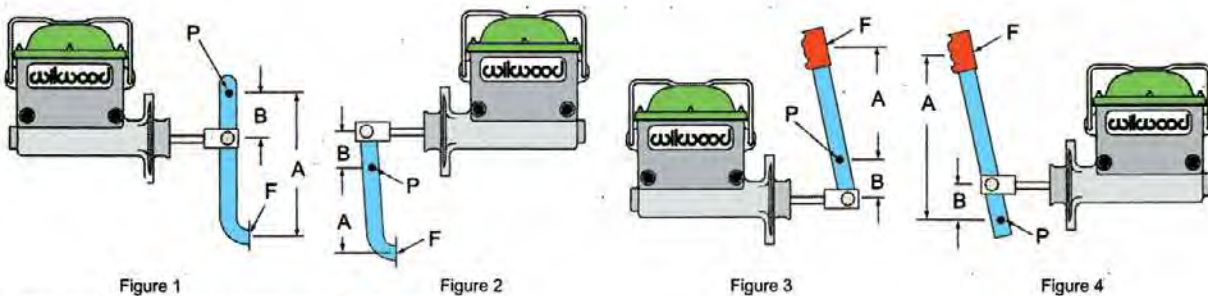

Figure 1

Figure 2

Figure 3

Figure 4

A = Distance from pivot point to middle of push/pull point • B = Distance from pivot to point of push on master cylinder • P = Pivot point • F = Force or push

Pedal & Handle Assemblies for Dragsters, Altered & Funny Cars

S&W dragster, altered and funny car pedals and brake handles are lightweight and easy to install. All pedals are designed to provide the correct geometry without over-centering the linkage or causing excessive brake pressure.



15-029



15-030



15-034



15-035



15-033

P/N

- 15-029 F/C clutch pedal
- 15-030 Altered brake pedal
- 15-031 F/C brake handle, with fire lever, without grips
- 15-033 Dragster brake handle
- 15-034 Dragster gas pedal with toe loop, heel pivot
- 15-035 F/C-Altered gas pedal with toe loop, center pivot
- 15-037 Dragster clutch pedal
- 15-038 Dragster push type brake handle (adapts to 15-354 - requires removal of pedal from 15-354 to mount handle)
- 15-041 Roadster Brake Pedal & Master Cyl. Mount Kit
- 15-046 Brake handle pivot kit
- 15-353 Mopar MC adapter for 15-354 pedal
- 15-354 Dragster brake pedal with master cylinder mount
- 15-358 Hanging brake pedal with master cylinder mount
- 15-356 Brake pedal assembly for dual master cylinders with balance bar
- 60-328 Wilwood Brake Pedal Mount
- 15-033-G Brake Handle Grips

Adjustable Throttle Pedal



S&W's adjustable throttle pedals make it easy to adjust your car to a different size driver. Simply unbolt the unit and move the cable mount, pedal stop and pedal as one unit. (Weld-In Avail. for OEM Floors)

P/N

- 05-120 Adjustable throttle pedal (Bolt-In)
- 15-049 Door Car Adj. throttle pedal (Welds to OEM Floor)



15-038 Master Cylinder & Mount - not included



15-354



15-046



60-328

- 5 mounting positions
- 5" Pedal adjustment
- 10" x 2-3/4"
- 1/8" Mild steel
- Welds to frame and mounts pedal #15-354

Brake Line Kits

Brake line kits include all necessary fittings, tabs, hoses and hard line to complete your brake line plumbing project.

P/N

- 94-102 Funny car or Altered with 4 wheel brakes
- 94-103 Altered with rear brakes only
- 94-105 Hardtail or Slip Joint Dragster

P/N

- 94-107 Door Car with Mopar or Wilwood master cyl.
- 94-107S Door Car with Strange master cylinder
- 94-108 S&W 4-link Dragster
- 94-109 S&W Swing Arm Dragster

Brake Line Plumbing for DoorSlammers

- A) Mopar style dual master cylinder will require (1) part# 94-2357, 9/16"-20 to #3 fitting for the front brakes and (1) part# 94-2356, 1/2"-20 to #3 fitting for the rear brakes. Newer style Strange master cylinders use (2) of 94-2356 11/2" fittings instead of 1 of each!! Please check your master cylinder before ordering.
Note: the rear brake lines should be installed into the out let on the master cylinder, closest to the push rod. Secure the front and rear 3/16" steel brake lines to the #3 fittings on the master cylinder with a part# 94-3591, #3 tube nut and part# 94-3667-1 tube sleeves.
- B) In-line residual pressure valve.
Note: the residual valves should be installed as close to the master cylinder as possible, use a 2 lbs valve for disc brakes and a 10 lbs valve for drum brakes. Use (2) of part# 94-4244, #3 to 1/8" pipe fittings to go into each valve, securing the 3/16" steel line with 2 of part # 94-3591 tube nuts and part# 94-3667-1 tube sleeve.
- C) 3/16" steel brake line. (Sold in 25' rolls - part #55-805)
- D) Wilwood or Strange brake caliper. Adapting the brake hose to the caliper with a part# 94-4244 #3 to 1/8" pipe fitting.
Note: this adaptor will vary for drum brakes wheel cylinders.
- E) Adjustable proportioning valve. Use 2 of part# 94-4244 #3 to 1/8" pipe fittings to go into the proportioning valve, securing the 3/16" steel line with 2 of part # 94-3591 tube nuts and part# 94-3667-1 tube sleeves.
- F) Line lock. Use 2 of part# 94-4244 #3 to 1/8" pipe fittings to go into the line lock, securing the 3/16" steel line with 2 of part # 94-3591 tube nuts and part# 94-3667-1 tube sleeves.
- G) Part# 94-4330 #3 steel bulkhead tee and part# 94-4387 bulkhead nut. Securing the 3/16" steel line with 2 of part # 94-3591 tube nuts and part# 94-3667-1 tube sleeves.
- H) Part# 94-5606, 24" #3 steel braided brake hose with straight female fittings on each end.
- I) Part# 94-2770 #3 steel bulkhead fitting and part# 94-4387 bulkhead nut.
Securing the 3/16" steel line with 5 part # 94-3591 tube nut and part# 94-4667 tube sleeve.
- J) Part# 94-4330 #3 steel bulkhead tee and part# 94-4387 bulkhead nut.
Securing the 3/16" steel line with part #94-3591 tube nut and part# 94-3667-1 tube sleeve.
- K) Part# 94-5603 15" #3 steel braided brake hose with straight female fittings on each end.
- L) Part# 60-314 mounting tab for bulkhead fitting. Trim to fit & weld in place.

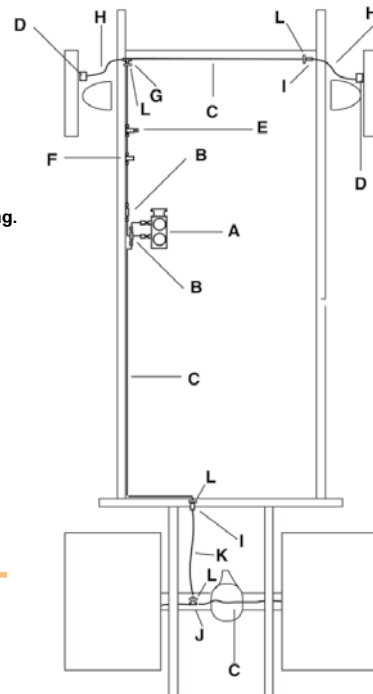

Parts List for 4-Wheel Brake Line System

Qty.	P/N		Qty.	P/N	
2	94-2770	#3 steel bulkhead fitting	1	55-805	25' roll 3/16" steel hard brake line
2	94-4330	#3 steel bulkhead tee fitting	1	94-5603	15" #3 steel braided brake hose
4	94-4387	#3 steel bulkhead nut	2	94-5606	24" #3 steel braided brake hose
18	94-3591	#3 steel tube nut	1	94-2356	1/2"-20 to #3 steel fitting (Strange)
18	94-3667-1	#3 steel tube sleeve	1	94-2357	9/16"-20 to #3 steel fitting (Strange)
14	94-4244	#3 to 1/8" pipe steel fitting	3	60-314	Universal tab with 3/8" hole

LATERAL ENGINE LIMITERS

S & W lateral engine limiters are highly recommended for any car with an aluminum front motor plate and an engine mid-mount. Lateral engine limiters provide a simple, but positive, means of limiting any forward or rearward movement of the engine and transmission during acceleration or deceleration. These limiters do away with the need for a solid transmission mount which can impose excessive loads on the tailshaft.

P/N

- 20-606 Universal doorslammer engine limiter (single)

Dragster
Limiters See PAGE 91

P/N

- 20-607 Universal doorslammer engine limiter (dual)



TRANSMISSION ADAPTERS

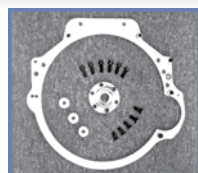

Ford & Mopar owners, adapting the race proven Powerglide or Turbo 350/400 to your combination just got easier! S&W Race Cars adapter kits make it easy to install a Chevrolet Powerglide or Turbo 350/400 behind the small & big block Ford as well as small & big block Mopars. Designed using original Ford Motorsport & Mopar Performance engine drawings these adapters are custom waterjet fabricated from 1/2" 6061-T6 aluminum. Each kit comes complete with all necessary installation hardware and the necessary crankshaft pilot adapter. Each kit is available profiled as shown or in a 2' x 2' version for the builder who wants to shape the profile to suit a specific need.

P/N

- 20-800 Small block Ford to powerglide, 2' x 2'
- 20-800P Small block Ford to powerglide, profiled
- 20-801 351M, 400, 429, 460 Ford to powerglide, 2' x 2' with 1.375" crankshaft pilot
- 20-801P 351M, 400, 429, 460 Ford to powerglide, profiled with 1.375" crankshaft pilot
- 20-802 351M, 400, 429, 460 Ford to powerglide, 2' x 2' with 1.848" crankshaft pilot
- 20-802P 351M, 400, 429, 460 Ford to powerglide, profiled with 1.848" crankshaft pilot
- 20-803 Small block Mopar to powerglide, 2' x 2'
- 20-803P Small block Mopar to powerglide, profiled

P/N

- 20-804 Big block Mopar to powerglide, 2' x 2' with 6 bolt crankshaft
- 20-804P Big block Mopar to powerglide, profiled with 6 bolt crankshaft
- 20-805 Big block Mopar to powerglide, 2' x 2' with 8 bolt crankshaft
- 20-805P Big block Mopar to powerglide, profiled
- 20-806 Honda VTEC to Chevy
- 20-807 Honda 'H' Series to Chevy
- 20-80801 Toyota to Chevy
- 20-80901 Toyota to BB Mopar



MOTOR PLATES - UNIVERSAL FRONT & MOUNTING KITS

Motor Plate Combo Kits



P/N

- COMBO-KIT-3 Profiled Motor Plate Combo
- COMBO-KIT-4 Standard Motor Plate Combo

Using a front motor plate will help eliminate frame flex and rotational engine movement, while providing additional header clearance. Front motor plates greatly ease engine installation. S&W front motor plates are made of 1/4" 6061-T6 aluminum. S&W front plate are 36" wide (except 20-213)

P/N

- 20-201 Small block Chevy
- 20-201P Small block Chevy - Profiled
- 20-202 Big block Chevy
- 20-202P Big block Chevy - Profiled
- 20-203 Cleveland Ford
- 20-203P Cleveland Ford - Profiled
- 20-204 429-460 Ford
- 20-204P 429-460 Ford - Profiled
- 20-204-BD 429-460 Ford for belt drive
- 20-204P-BD 429-460 Ford for belt drive- Profiled
- 20-204CSI 429-460 Ford w/ CSR water pump
- 20-204CSIP 429-460 Ford-Profiled w/CSR water pump
- 20-205 383-426-440 Mopar
- 20-205P 383-426-440 Mopar - Profiled
- 20-206 318-340-360 Mopar
- 20-206P 318-340-360 Mopar - Profiled
- 20-208 70-93 289-351W Ford
- 20-208P 70-93 Small Block Ford - Profiled
- 20-208-BD 70-93 289-351W Ford for belt drive
- 20-208P-BD 70-93 Small Block Ford - Profiled
- 20-208CSI 70-93 289-351W Ford w/CSR water pump(teardrop)
- 20-208CSIR 70-93 289-351W Ford w/CSR water pump(round)
- 20-208MEZ 70-93 289-351W Ford w/Meziere water pump
- 20-208PMEZ 70-93 289-351W Ford - Profiled w/Meziere water pump
- 20-209 94-98 289-351W Ford
- 20-209MEZ 94-98 289-351W Ford w/Meziere water pump
- 20-209P 94-98 Small Block Ford - Profiled
- 20-209PMEZ 94-98 Small Block Ford - Profiled w/Meziere water pump
- 20-210 65-69 289-302 Ford
- 20-210P 65-69 Small Block Ford - Profiled
- 20-211 64-67 & 78-79 Buick V6, also fits 61-63 215" 8 cyl. Buick 326, 350, 389, 421, & 455 "real" Pontiacs
- 20-212 LS-1 Chevy (2 piece)
- 20-214P DRC Block - Profiled
- 20-214 DRC Block
- 20-216 390 /427 FE - Ford
- 20-217 Buick with Belt Drive



See ALL COMBO KITS on Pg.12

F/C, Altered & Dragster Plates See Pg 95 & 93

Profiled motor plates are made standard with lightening "diamonds." If you'd like these left out of your front motor plate, please tell your S&W sales representative

Universal Motor Plate Mounting Kits

S&W motor plate mounting kits include all necessary brackets and hardware to simplify the mounting of your front motor plate

P/N

- 20-200 Mounting kit for profiled motor plate
- 20-215 Mounting kit for standard motor plate

20-215

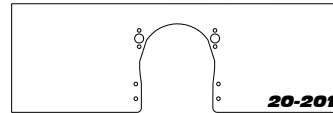

20-201

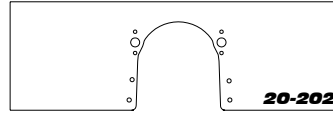

20-202

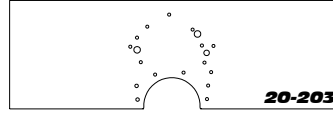

20-203

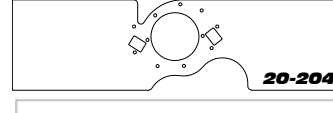

20-204

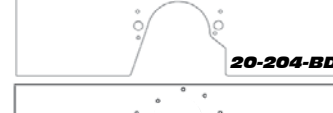

20-204-BD

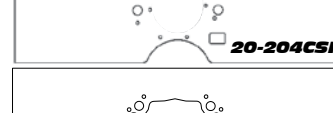

20-204CSI

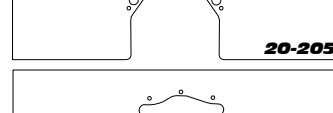

20-205

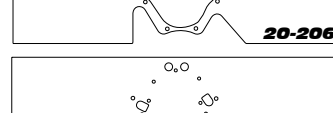

20-206

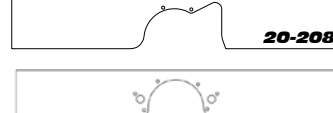

20-208

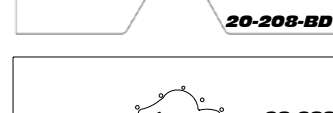

20-208-BD

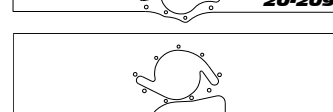

20-209

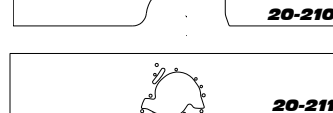

20-210

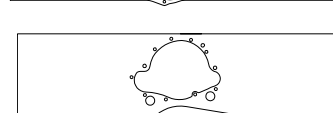

20-211



20-212



20-216

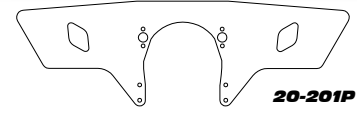

20-201P

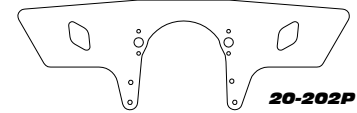

20-202P

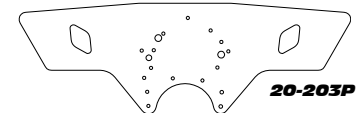

20-203P

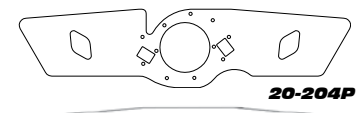

20-204P

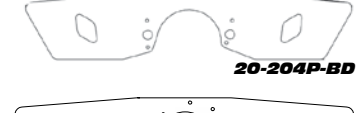

20-204P-BD

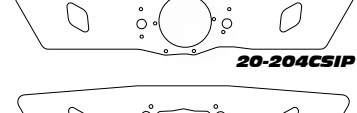

20-204CSIP

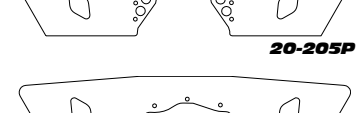

20-205P

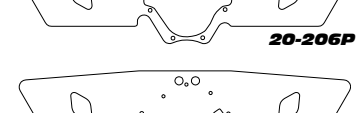

20-206P



20-208P

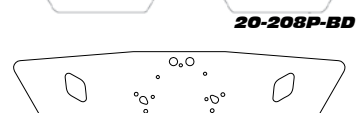

20-208P-BD

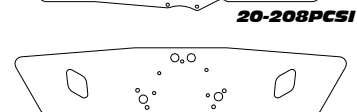

20-208PCSI

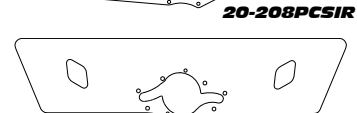

20-208PCSIR

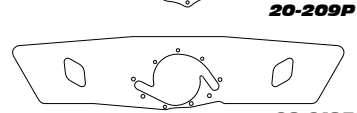

20-209P



20-210P

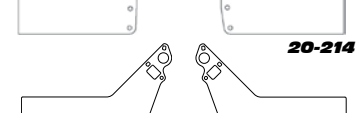

20-214



20-213



MOTOR PLATES - DIRECT FIT FRONT & PULLEY SPACERS

Direct Fit Front Motor Plates

S&W fitted front motor plates are available for most small block and big block Chevrolets with the motor in the stock location. All fitted motor plates are made from 1/4" 6061-T6 aluminum and include weld-on frame mounting tabs and Grade 8 mounting hardware.

P/N	
20-300	55-56-57 Chevy, small block
20-301	67-69 Camaro, 68-78 Nova, small block
20-302	S-10 Chevy Pick Up, small block
20-303	70-81 Camaro, small block
20-304	63-82 Corvette, small block
20-306	Vega and Monza, small block
20-307	67-81 Camaro, 68-78 Nova, big block
20-307ALT	67-81 Camaro, 68-78 Nova, big block for use with S&W low alternator mount
20-310	63-82 Corvette, big block
20-311	55-56-57 Chevy, big block
20-312	Monza-stock sm blk & large steering box
20-313	Ford 429 Mustang 69-70
20-308	78-83 BB Chevy Malibu
20-309	78-83 SB Chevy Malibu

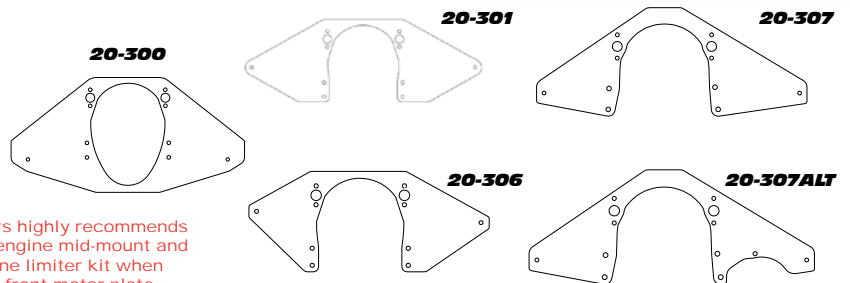

S&W Race Cars highly recommends the use of an engine mid-mount and lateral engine limiter kit when installing a front motor plate.

20-225



Pulley Spacers

Designed for use on small & big block Chevrolets with 1/4" alum. front motor plates installed to space the harmonic balancer pulley out to match the added thickness of the motor plate. Not required when using electric water pump or drive.

P/N	
20-225	Pulley spacer for Chevy balancer
20-226	Pulley spacer for Ford balancer - 4 bolt

MID MOUNTS - UNIVERSAL / DIRECT FIT & MOUNTING KIT

Universal Mid-Mounts

The perfect companion for the S&W universal front motor plate, S&W universal mid-mounts are available for all popular applications. S&W mid-mounts are precision water jet cut and provide additional stiffness when used with an S&W front motor plate.

Note:
Universal mid-mount # 20-401 fits the following models, 67-81 Camaro, big or small block and 68-78 Nova, big or small block. Note: Some trimming may be required for header clearance.

P/N	Complete w/Frame Mounting Tabs & Grade 8 Mounting Hardware
20-401-090	Small and big block Chevy - .090" mild steel
20-401-120	Small and big block Chevy - .120" mild steel
20-402	289-302-351 C & W Ford - 1/8" mild steel
20-403	351M-400-429-460 Ford - 1/8" mild steel
20-404	383-426-440 Mopar - 1/8" mild steel, 727 trans
20-405	318-340-360 Mopar - 1/8" mild steel 727 trans

P/N	Do NOT Include Tabs & Hardware
20-411	"Real" Pontiac & Olds V8 - 1/8" mild steel
20-416	390 /427 FE - Ford - 1/8" mild steel
20-701	Small and Big Block Chevy - 1/4" 6061-T6 alum.
20-702	289-302-351 C & W Ford - 1/4" 6061-T6 alum.
20-703	351M-400-429-460 Ford - 1/4" 6061-T6 alum.
20-704	383-426-440 Mopar - 1/4" 6061-T6 alum. 727 trans.
20-705	318-340-360 Mopar - 1/4" 6061-T6 alum. 727 trans.
20-711	"Real" Pontiac & Olds V8 - 1/4" 6061-T6 alum.
20-716	390 /427 FE - Ford - 1/4" 6061-T6 alum.

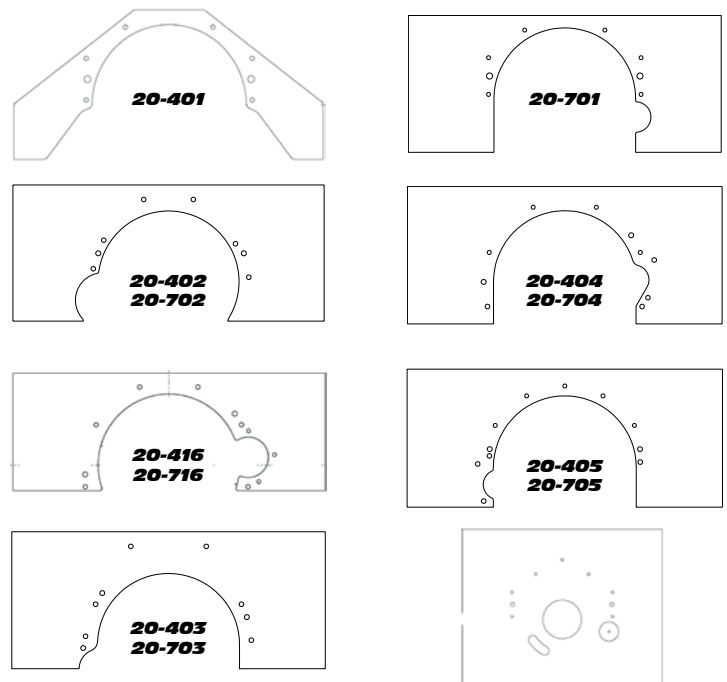

Funny Car & Altered Plates on PAGE 95

DRAGSTER Plates on PAGE 93

Mid-Mounts Mounting Kit

Designed for use with any S&W mid-mount, this kit include 2 plates, 4 gussets and all necessary hardware.

P/N	
20-406	Universal mid-mount mounting kit.



20-406

Direct Fit Mid-Mounts

Designed for use with the S&W pre-fitted front motor plate, pre-fitted mid-mounts are available for most small block and big block Chevrolets. All pre-fitted mid-mounts come complete with frame mounting tabs and Grade 8 mounting hardware.

P/N	
20-125	MONSTER TRUCK Chevy, big block - 1/4" Alum.
20-501	55-56-57 Chevy, small or big block - Steel
20-502	S-10 Chevy Pick Up, small or big block - Steel
20-509	63-82 Corvette, small or big block - Steel
20-511	Vega-Monza, small block - Steel
20-508	78-83 Chevy Malibu, small or big block - Steel
20-712	S10 Mid Plate - 1/4" Alum.

CUSTOM Engine or Mid Plate

P/N	Customer must supply drawing or template.
20-106	Custom Engine or Mid Plate - 1/4" Alum.
20-124	Custom Engine or Mid Plate - 3/8" Alum.



DRIVESHAFT COMPONENTS

Tube Type Driveshaft Components

For the extra strength and reliability of drive shafts used in competition, S&W relies on Strange Engineering and Mark Williams driveshaft components. S&W can fabricate a complete driveshaft to your specs or supply you with the individual components to "do-it-yourself."

P/N

- 30-010 Pinion-yoke, 9" Ford, 35-spline, billet steel, 1350 joint
- 30-011 Pinion-yoke, 8-3/4 Mopar, 10-spline, billet steel, 1350 joint
- 30-020 Driveshaft weld-yoke - 1350 U-Joint
- 30-025 Driveshaft weld-yoke - 1330 U-Joint
- 30-026 Driveshaft weld-yoke - 1310 U-Joint
- 30-030 Pinion-yoke, Mopar, 29-spline, heavy duty, 1350 joint
- 30-031 Pinion-yoke, 8-3/4", 29-spline
- 30-032 Pinion-yoke, 12-bolt Chevy, heavy duty, 1350 joint
- 30-033 Pinion-yoke, 9" Ford, 28-spline, heavy duty, 1350 joint
- 30-034 Pinion-yoke, 9" Ford, 35-spline, heavy duty, 1350 joint
- 30-035 3/8" U-Bolts for 1350 size U-joint (pair)
- 30-037 Pinion-yoke, Mopar, 29-spline, heavy duty, 1330 joint
- 30-039 Pinion-yoke, Mopar, 29-spline, Chevrolet 1310 joint
- 30-063 Pinion-yoke, 8.5" Chevy, 30-spline, 1350 joint
- 30-040 5/16" U-Bolts for 1330 size U-joint (pair)
- 30-041 1350 U-Joint, heavy duty - see drawing on page 63
- 30-042 1330 U-Joint, heavy duty - see drawing on page 63
- 30-043 1310 U-Joint, heavy duty - see drawing on page 63
- 30-1646 1310 to 1350 conversion U-Joint, heavy duty
- 30-050 Transmission slip-yoke, 32-spline, Turbo 400, Doug Nash, T-10, heavy duty, 1350 joint
- 30-051 Transmission slip-yoke, 16-spline, Lenco heavy duty, 1350 joint
- 30-054 Transmission slip-yoke, 30-spline, Torqueflite, billet steel, 1350 joint
- 30-055 Transmission slip-yoke, 32-spline, Turbo 400, billet steel, 1350 joint
- 30-056 Transmission slip-yoke, 27-spline, Powerglide, Turbo 350, billet steel, 1350 joint
- 30-057 Transmission slip-yoke, 16-spline, Lenco billet steel, 1350 joint
- 30-058 Transmission slip-yoke, 27-spline, Powerglide, Dedenbear needle bearing tailhousing, 1350 joint
- 30-059 Transmission slip-yoke, Jerico - roller, 1350 joint
- 30-061 Transmission slip-yoke, 27-spline, Powerglide, Turbo 350, heavy duty, 1310 joint
- 30-062 Transmission slip-yoke, 27-spline, Powerglide, Turbo 350, heavy duty, 1350 joint
- 3x083TDS 3" diameter .083 wall driveshaft tubing (sold per foot)

S&W Race Cars can custom fabricate a maximum strength driveshaft for drag race applications. Please refer to the ordering instructions on page 33 or call the S&W tech line for more information.

30-055

30-058

30-050

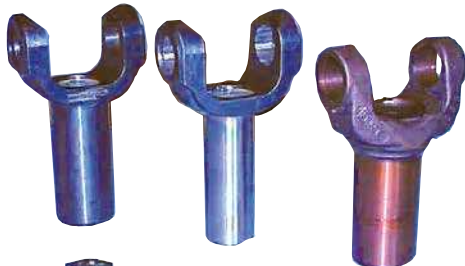

30-039



30-033



30-010



30-025



30-026



30-020



30-221

30-247

30-223

30-229

30-249

Carbon Fiber Driveshafts

QA1 and Mark Williams Avail.

QA1 carbon fiber driveshafts is different from the rest. From years of research and development to filament winding in-house to using 3M™ Matrix Resin, QA1's carbon fiber driveshafts are the highest in quality and performance



P/N

00-072

Fiber Driveshaft

Driveshafts & Couplers for Funny Cars & Dragsters

Designed for use in race cars with a solid mounted rear end, these drive shafts are machined from 4340 aircraft alloy steel and are available in lengths from 4" to 28" with 16 or 32 splines. Couplers are available for all popular transmissions and rear ends.



30-215

30-216

30-110

P/N

- 30-109 Mark Williams 1-3/8" 32-spline driveshaft, (12" or Less)
- 30-110 Mark Williams 1-3/8" 16-spline driveshaft, (28" or Less)
- 30-214 1-3/8" 16-spline sleeve
- 30-215 1-3/8" 32-spline sleeve
- 30-216 1-3/8" driveshaft clamp
- 30-220 1-3/8" 16-spline female coupler
- 30-221 1-3/8" 16-spline male coupler
- 30-223 1-3/8" 32-spline female coupler
- 30-224 1-3/8" 32-spline male coupler
- 30-225 Mopar 29-spline female pinion coupler
- 30-226 Mopar 10-spline female pinion coupler
- 30-227 Ford 9" 28-spline female pinion coupler
- 30-229 Ford 9" 35-spline female pinion coupler
- 30-230 Ford 9" 35-spline male pinion coupler
- 30-231 57-64 Oldsmobile female pinion coupler
- 30-232 12-bolt Chevy female pinion coupler
- 30-240 Steel lock ring for 30-249 & 30-249L
- 30-246 Torqueflite transmission coupler, male, 5-3/4" long
- 30-247 Powerglide transmission coupler, male, 3-7/8" long
- 30-248 Powerglide transmission coupler, male, 6-3/4" long
- 30-249 Powerglide transmission coupler, male, std. 2 piece distance required 4" from end of trans spline to pinion coupler
- 30-249L Powerglide transmission coupler, male, long 2 piece distance required 4" - 6" from end of trans spline to pinion coupler
- 30-252 Turbo 400 Transmission coupler, male, 3-7/8" long
- 30-253 Turbo 400 Transmission coupler, male, 6-3/4" long
- 30-254 Powerglide transmission coupler male, 8" long
- 45-411 9" Ford coupler spacer

Note: required when using coupler with stock Ford pinion support.

CUSTOM DRIVESHAFTS

Your race car is only as strong as its weakest component and twenty year old OEM drive shafts just won't hold up. High horsepower engines, transmission brakes and sticky tire compounds will destroy inferior components. S & W Race Cars custom built drive shafts are specifically designed to withstand the continuous abuse and punishment of the modern drag race vehicle. Driveshafts are made to your specifications from heavy-duty, 3"x .083" wall tubing, lathe-cut and faced to insure a precision fit. Severe duty weld yokes are properly phased and heli-arc welded for maximum strength. To correctly build your driveshaft, we require the following: All measurements must be made at ride height, and with the car weight on the rear axle housing. Allowing the rear to hang will result in incorrect measurements. The transmission slip yoke should be slid onto the output shaft until it bottoms out, then pulled back one inch. Failure to allow one inch clearance will result in transmission or driveshaft damage during suspension travel. The following information will also be required for all driveshaft orders. • Transmission type • Rear end type • Driveshaft length • Front u-joint dimension & Rear u-joint dimension (A and B)

Not intended for street use • 48" Maximum overall length

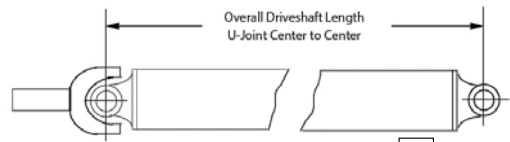

"A" dim. "B" dim. Type Description

- 1-3/16" 3-5/8" Super duty 1350
- 1-1/16" 3-5/8" Heavy duty 1330
- 1-1/16" 3-7/32" Standard 1310

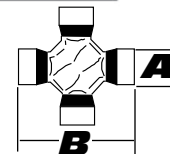

Please measure all four caps (A) and across both spans (B)

HEADERS & HEADER KITS

Dynatech

S&W now offers Dynatech, fully assembled dragster headers. All headers come fully assembled with Dynatech's own, slip on "tunable" collector muffler. Dynatech mufflers are available separately and are easily adaptable to your existing headers. Dynatech mufflers are available for most popular header primary tube sizes please call for more information. Other brands available. Please Ask.

P/N

- 25-500-904700 Pro Stock header - BB-Chev (2-1/4" tube) Collector or mufflers not included
- 25-500-904701C Pro Stock header - BB-Chev (2-1/4"-2-3/8" step) CHROME includes 4-1/2" collectors
- 25-500-904801C Pro Stock header - BB-Chev (2-3/8"-2-1/2" step) CHROME includes 4-1/2" collectors
- 25-72-32510 Vortex insert cone assembly (3-1/2" collector • sold each)
- 25-72-32530 Vortex insert cone assembly (4" collector • sold each)
- 25-72-32540 Vortex insert cone assembly (4-1/2" collector • sold each)
- 25-80-02518C Merge collector (2-1/4" tube - 4" outlet • sold each) NITROPLATE COATED
- 25-83-512352C Standard collector (2" tube - 3-1/2" outlet • sold each) NITROPLATE COATED
- 25-83-712402C Standard collector (2-1/4" tube - 4" outlet • sold each) NITROPLATE COATED
- 25-83-812402C Standard collector (2-3/8" tube - 4" outlet • sold each) NITROPLATE COATED
- 25-83-812452C Standard collector (2-1/4" tube - 4-1/2" outlet • sold each) NITROPLATE COATED



Header Collector Bezels

Stainless steel header collector bezels are here! .050" thick S.S. with Mill Finish to fit popular collector sizes. Kits include (2) Bezels and S.S hardware. Custom sizes and shapes are available. Call 1-800-523-3353

- 95-094 4" Collector Kit
- 95-095 4.5" Collector Kit
- 95-096 5" Collector Kit



Ask Us About Custom Sizes & Shapes!



EGT System

Now you can monitor your exhaust gas temperature without the expense of an onboard computer or without the danger of trying to read an analog pyrometer at finish line speeds. Features: • Digital readout • Maximum temp. recall - read max temp after run not during! • Simple to install - uses self contained 9 volt battery • Shielded cable, no R.F. interference



P/N

- 85-4100 Complete EGT System

Crankcase Evacuation System

Reduces crankcase pressure throughout entire rpm range for increased piston ring seal, reduced intake charge contamination, and fewer oil leaks. Track and dyno tests prove increases in engine performance Includes 2 each: Oil Separators/Breathers, Breather/Filler Cap Grommets, One-Way Check Valve and Weld-In Nipple for header collector, use with 5/8" dia. hose P/N 85-25900

Racing Vacuum Pumps & Accessories



Randy Krause



Tom Hoosigan



social @SWRACECARS

website SWRACECARS.COM

Batteries

PowerMaster &
ODYSSEY
Batteries Available

ODYSSEY
BATTERY



P/N

- 85-403 S925 Battery - 12v
- 85-404 S1200 Battery - 12v
- 85-406 D1600 Battery - 16v
- 85-416 16v battery charger
- 85-417 Voltage reducer
- 85-409 S1600 Battery - 16V - weighs 33#
- 85-680MJ ODYSSEY Extreme Series Battery Model PC680MJ
- COMBO-KIT-8 Battery Combo Kit

Push/Pull Battery Disconnect

This kit allows the builder to mount the master disconnect near the battery and run a small push/pull rod through the rear valance. Kit includes brackets, swing arm linkage 18" aluminum tube actuator link and all necessary bushings and fasteners. Aluminum parts are black anodized for an attractive finish. Master disconnect switch sold separately.



P/N

- 85-249 Kit Shown
- 85-242 Push Off Handle for 85-249 kit has 1/4-20 male thread on back
- 85-248 Cockpit Disconnect
- 85-250H Handle to fit Master Disconnect Switch 85-250
- 85-250HL Long Handle to fit Master Disconnect Switch 85-250

Electrical Components

S & W stocks a full line of high quality switches and electrical components to aid you in correctly wiring your car. All components are U.L. approved and constructed to withstand the rigors of drag racing.

P/N

- 85-001 Adjustable transbrake button
- 85-002 Transbrake button with cord - green button
- 85-003 Transbrake button mount for butterfly steering wheel
- 85-005 Transbrake button mount for butterfly steering wheel (closed top)
- 85-009 Transbrake button with cord - "mushroom" button
- 85-229 Toggle switch - 35 amp, 3 position on-off-on, std. handle
- 85-230 Momentary starter button - 60 amp
- 85-232 Toggle switch - 35 amp, 2 position on-off, long handle
- 85-233 Toggle switch - 35 amp, 2 position on-off, std. handle
- 85-250 Master disconnect switch
- 85-252 Battery charging posts
- 85-253 Battery charging plugs
- 85-254-3 Battery cable junction block
- 85-500 Centech fuse panel - holds 4 ATO type fuses
- 85-922 Painless power relay

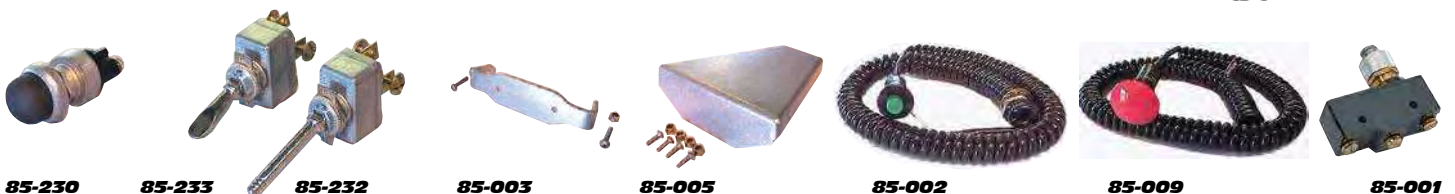

- 85-230
- 85-233
- 85-232
- 85-003
- 85-005
- 85-002
- 85-009
- 85-922
- 85-001

Battery Mounts & Cable Kits

S & W stainless steel battery mounts are designed for light weight and high strength. The base measures 6-7/8" x 11" and fits up to a group 24 battery. The 3/8" diameter hold down meets all sanctioning body requirements and will fit batteries up to 9" tall. A perfect companion to the S & W battery mount, our battery cable kit is available in single or dual battery models. Each kit features 20 feet of high grade cable, color coded shrink tubing and enough ends to attach the battery, starter, ground cable and master disconnect switch. Additional cable or ends sold separately.

P/N

- 05-036 Battery mount for Odyssey battery
- 60-342 Battery mount kit - single
- 60-343 Battery mount kit, tube type - single
- 60-345 Battery mount kit, billet, powermaster 1200
- 60-346 Battery mount kit, billet, Optima
- 60-347 Battery mount kit, billet, 16 volt powermaster
- 85-260 Battery cable kit - single
- 85-261 Battery cable kit - dual
- 85-262 Single cable end - battery post
- 85-263 Dual battery end - battery post
- 85-264 3/8" eye battery cable end
- 85-267 1/0 gauge electrical cable - per foot

Made of
corrosion resistant
Stainless Steel!!



- 60-342
- 05-036
- 60-343
- 85-264
- 85-262
- 85-263
- 85-260
- 85-253
- 85-254-3
- 85-500
- 85-922

Super-Duty Complete Wiring Kit by K&R



"SUPER DUTY" Complete Wire Kit has been the leading choice of most all the major chassis shops. This kit is the most rugged and complete system available at any price! It dramatically simplifies any wiring job. The Switch Panel and separate Fuse/Relay Panel are interconnected with a cable assembly that simply plugs in. Mount the Relay Panel assembly in a convenient location (usually near the ignition box) and connect the switch panel connector. This eliminates the "clutter" of wiring to switches and relays along with saving tons of time. And as a bonus, there are convenience terminals on the rear of the switch panel for powering gauges, buttons, gauge lights, interior lights, grounds, etc. Also, as with all the K&R Switch Panels, there are blue LED's on the rear of the Switch Panel that "illuminate" to make for an absolutely awesome interior glow at night. System comes complete with all the colored and labeled wires including: Ignition, Fuel Pump, Fan, Water Pump, Delay Box, Transbrake, Throttle Stop, Pro-Stage, Lights, Starter, Tach, RPM Switch, 2-Step, Shift Timer, and Water Temp. Other unlabeled colored wires include: Ground, Shifter, Neutral Safety, Remote Start, Crank Trigger, Coil Wires, Alternator (10ga.), Ignition Power & Ground (10ga.), and main Power Wire (8ga.). Also included with every kit: All necessary quality terminals, heat shrink, wire ties, starter solenoid, colored laminated poster size wiring diagram. COMPARE all this with other manufacture's systems.

P/N
85-925 K&R Super-Duty Complete Kit

Alternator Mounts

Designed for the S&W Race Cars Super Class dragster, but easily adapted to most cars, this mount tucks the alternator down and out of the way.

P/N
85-227 Big block Chevy, full size alternator
85-228 Big block Chevy, mini alternator
85-235 Big block Chevy, Powermaster mini alternator
85-237 Small block Chevy, full size alternator
85-238 Small block Chevy, mini alternator
85-239 Big block Chevy, Powermaster mini alternator
85-243 67-69 Camaro / 68-72 Nova big block Chevy, full size alternator
85-245 67-69 Camaro / 68-72 Nova big block Chevy, mini alternator



85-243 & 85-245
May require modifications to front motorplate



85-228
Front view



Mini Headlight Kits

"Mini" & "ULTRA SMALL" headlights are perfect for mounting on dragster a-arms or in the nose. Please call.



P/N
85-257 Black Mini headlights - pair - 2 lbs. 3" Long x 2-1/4" High x 3-5/8" Deep
60-321 Headlight mount tabs - A-Arm mount - ea.
60-322 Headlight mount tabs - Chassis mount - ea.
85-270 Black ULTRA SMALL headlight with base - ea. 3.5oz. 2" front to back, 1.33" diameter

Starters

S & W Race Cars stocks East Coast Auto Electric starters for big or small block Chevy engines. Their high torque gear reduction design spins the engine faster while requiring less amps. The small size allows more clearance between oil pan and headers. Starter fits all Chevrolet V-8 and in-line 6 cylinders with 153 or 168 tooth flywheels.



EAST COAST
AUTO ELECTRIC
Alternators - Starters - Batteries

P/N
85-2070 East Coast Chevy mini-starter
85-2072 East Coast Chevy super mini-starter for ultra high compression engines

Alternators

S&W stocks East Coast Auto Electric alternators. S&W can fill your requirements from chrome plated show car versions to 16 volt drag race models. Please call if what you need is not listed here.



P/N
85-2002 East Coast super mini - one wire
85-2003 East Coast super mini - 120 amp one wire
85-2006 East Coast super mini 16 volt

Painless Wiring Components

Championship quality race cars require championship quality switch panels, wiring harnesses and components. Today's race cars are dependent on proper voltage flow to operate all the sophisticated electrical components required to remain competitive. Painless Wiring of Fort Worth, TX, has developed a line of electrical components designed to help you wire your race car quickly, easily and correctly the first time. Each Painless Wiring kit comes complete with everything you need to get the job done.

PAINLESS
PERFORMANCE PRODUCTS



85-917



85-918

P/N
85-917 8 Switch Control Panel with Fuses and Wiring Harness
85-918 Dragster Control Panel with Fuses and Wiring Harness

Call Us with Your Needs!

Dragster Tail Light Kit with Bullet Mount

INCLUDES; Red LED Light, Bullet Tube End and Tubing.

Fitting, Drilling and Welding required.

P/N 85-326 Dragster Tail Light



Delay Boxes & Components

Digital Delay Electronics



We are a full line Digital Delay dealer. Call us with your needs 1-800-523-3353



Delay Box Mounting Kit

9-1/4" x 5-1/4" plate is slotted on the top for delay box mounting. Plate is welded to a 3/4" tube which can be welded to the floor, tunnel or drive-shaft loop. Delay box mount can also be used in conjunction with the 70-100, door car shifter mount



P/N

85-950 Delay Box mount

Mega Series Delay Boxes Feature Comparison Chart

Take notice that the Mega 80, 100 and 200 are geared towards bracket racers while the Mega 85, 350 and 450 include throttle stop timers and are geared towards super class racers. The 'easy to use' layout of these boxes include super large lit up display.

	MEGA 80	MEGA 85	MEGA 100	MEGA 200	MEGA 350	MEGA 400	MEGA 450
Face Size	5-1/16" x4-1/8" x1-3/4"	5-1/16" x4-1/8" x1-3/4"	5-15/16" x4-3/8" x1-1/2"	5-15/16" x4-3/8" x1-1/2"	6-11/16" x5" x1-3/4"	6-11/16" x5" x1-1/2"	6-11/16" x5" x1-3/4"
Overall Size	7-1/16" x4-1/8" x1-3/4"	7-1/16" x4-1/8" x1-3/4"	7-15/16" x4-3/8" x1-1/2"	7-15/16" x4-3/8" x1-1/2"	8-11/16" x5" x1-3/4"	8-11/16" x5" x1-1/2"	8-11/16" x5" x1-3/4"
Crossover delay box	X	X	X	X	X	X	X
Multiple hits (2 delays) with late display	X	X	X	X	X	X	X
Tap up / Tap down	X	X	X	X	X	X	X
Starting line enhancer for bracket racing		X	X	X	X	X	X
Control for Pro Tree Easy Start System		X	X	X	X	X	X
Digital tachometer with peak rpm recorder				X	X	X	X
Tachometer Replay to playback entire run				X		X	X
Two 4 stage timers for nitrous / throttle stops		X (One 4 stage time)			X	X	X
Programmable throttle stop override					X	X	X
Shift activator to shift by rpm				X	X	X	X
Shift activator to shift by Time			X	X	X	X	X
Driver reaction tester	X	X	X	X	X	X	X
Lighted Display	X	X	X	X	X	X	X
Lighted Keypad	X	X			X		X
Separate screens for brkt & Pro Tree racing					X		X



CABLES & ACCESSORIES

Control Cables

S&W stocks a large inventory of high quality control cables, made specifically to our own strict requirements. Series 30 (3/16") cables are available with either clip-type or bulkhead ends, in both 2" and 3" stroke. Series 44 (1/4") cables are also available for special applications where greater durability is needed.

Note! - Cable length is measured from tip to tip
Jam Nuts sold separately

P/N

- 70-036 36" Cable - 33C
- 70-042 42" Cable - 33C
- 70-048 48" Cable - 33C
- 70-060 60" Cable - 33C
- 70-072 72" Cable - 33C
- 70-084 84" Cable - 33C
- 70-096 96" Cable - 33C
- 70-108 108" Cable - 33C
- 70-120 120" Cable - 33C
- 70-132 132" Cable - 33C
- 70-144 144" Cable - 33C
- 70-156 156" Cable - 33C
- 70-168 168" Cable - 33C
- 70-180 180" Cable - 33C
- 70-468 168" Chute Cable
- 70-500 Cable ball joint - 10-32 female thread
- 70-501 Cable ball joint - 1/4-28 male stud thread
- 70-504 Cable hook clip - dual cable
- 70-505 Cable hook clip - single cable
- 70-505-25 Cable hook clip 1/4" spacer
- 70-505-50 Cable hook clip 1/2" spacer
- 70-510 Cable clevis
- 70-515 Cable pivot with set screw
- 70-520 Cable pivot - threaded
- 70-525 Cable clamp - bolt together
- 70-65057 Cable mounting bracket - (square GM)
- 70-65058 Cable mounting bracket - (round GM & Ford)



70-500
&
70-501



70-515



70-520



64-503



75-118 / 75-119



Clip Type



Bulkhead Type

P/N

- 70-636 36" Cable - 33B
- 70-648 48" Cable - 33B
- 70-660 60" Cable - 33B
- 70-672 72" Cable - 33B
- 70-684 84" Cable - 33B
- 70-696 96" Cable - 33B
- 70-708 108" Cable - 33B
- 70-720 120" Cable - 33B
- 70-732 132" Cable - 33B
- 70-744 144" Cable - 33B
- 70-756 156" Cable - 33B
- 70-768 168" Cable - 33B
- 65-110 Jam nut for 40 series cables
- 65-508 Jam nut for 30 series cables
- 64-503 Female Rod End 3/16" RH



PRO-WERKS
Ultimate Silver
Jacket Cables
Available

P/N

- 75-118 Release clip for Deist chute pack 3/8" Cable
- 75-119 Release clip for Deist chute pack 1/4" Cable

Parachute Cables

- 70-469 180" - Clip type - 10/32 threads/bare wire ends
- 70-470 240" - Clip type



70-504

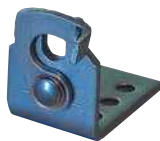

70-505



70-510



70-525



70-505-50



70-65057

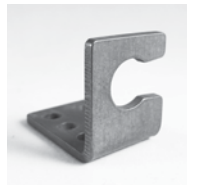

70-65058

If You Don't See What You Need, Please Ask!

SHIFTERS & ACCESSORIES

Shifters & Shifter Cable Conversions

S&W sells two of the most popular shifters on the market - the Outlaw and the Quarter Pro. Both feature a slim compact design, rear exit cables and are available with either an air or electric solenoid for automatic shifting. Shifters are sold without cable. Uses 33C cable sold below. Available for powerglide only
NEW: Aerospace Shifters NOW AVAILABLE!

P/N

- 70-043 BRP Quarter Pro Champion Series w/ electric solenoid shifter
- 70-044 BRP Quarter Pro Champion Series w/ CO2 solenoid shifter
- 70-045 BRP Outlaw Series w/ electric solenoid shifter
- 70-046 BRP Outlaw Series w/ CO2 solenoid shifter
- 70-046B BRP Outlaw Series w/ CO2 solenoid shifter with button
- 70-061 B&M Pro Bandit Shifter

Door Car Shifter Mounting Kit



Removable shifter mount allows the installation of Quarter Pro, Phantom or Outlaw shifters. The shifter bolts directly to a removable bracket which slides into (and secures with a bolt) a sleeve which may be welded to the chassis, tunnel or driveshaft loop. Can be used in conjunction with delay box mount, 85-950 which is sold separately.

P/N

- 70-100 Shifter mount for Phantom & Outlaw
- 70-101 Shifter mount for Bandit



70-061

Note:
ALL QUARTER PRO CHAMPION SERIES Handle & Body are Polished Aluminum with no decals.
(No Buttons Avail. & Black handle not Avail.)

Note:
ALL OUTLAW SERIES Handle & Body are Chrome with no decals.
(70-046B is Special Order item 4-6 week delivery)



70-043



70-045



70-046



Radiators

Working in conjunction with a leading racing radiator company, S&W has designed an all aluminum radiator to work with almost any dragster, altered or street roadster application. This radiator's overall size measures 18" wide by 19-1/2" tall and 2" thick. An overflow tube and drain are built in and hose connections are standard size. In addition, S&W has an all aluminum replacement radiator available for full bodied cars using the popular plastic Scirocco radiator. This unit measures 25" wide by 12-3/4" tall and 2" thick. This radiator accepts standard size hoses and provides superior cooling over the VW unit. Also available is a lightweight plastic or billet aluminum, 1-quart capacity overflow cans that works great with either radiator.

P/N

95-1150	Aluminum Radiator w/Fan for use with 05-114 mounting kit
95-1151	Aluminum Radiator for 95-1150
05-114	Mount kit for 95-1150 radiator & 94-006 trans cooler mounts radiator & cooler above transmission
95-3402	Aluminum Radiator - Dragster, Altered or S/R - Chevy
95-3402AN8	Aluminum Radiator
95-3402AN12	Aluminum Radiator - Dragster with #12 AN outlets
	Altered or S/R - Chevy
95-3402AN16	Aluminum Radiator - Dragster with #16 AN outlets
	Altered or S/R - Chevy
95-3402S	Shroud for Dragster radiator
95-3403	Mount kit for 95-3402 for cars with angled frame rail
95-3404	Pro/Stock Radiator - Dual right side
95-3408	Mount kit for 95-3402 for cars with horizontal frame rail
95-806	1 Quart overflow can
95-807	1 Quart billet overflow can
95-80240	S-10 Truck Alum. Direct Replacement (Afco)



95-80240



95-1150



95-3402



95-806

available in Purple, Orange, White, Blue, Red, Black & Yellow



95-807

Electric Fans

The best radiators on the market still require a high quality electric fan. S&W stocks a high flow 14" diameter fan that passes 2050 cfm at 2400 rpm. This fan is reversible and can be used in front of, or behind the radiator. We offer a 10" model too..

P/N

95-052	14" Heavy Duty Reversible Fan
95-16910	10" Fan
85-000	Replacement "feet" (ea)



Transmission Coolers

Your race transmission deserves more than just a street type transmission oil cooler. S&W uses and recommends the B&M Supercooler for all racing or high performance applications. This cooler's highly efficient, 100% aluminum "stacked plate" design is substantially stronger than other cooler types. This cooler's small size, only 10-1/4" x 11" x 1-1/2", make mounting easy and the 1/2" N.P.T. inlets make plumbing a snap. Also available, are B&M's New Trans Cooler Systems. Available in two convenient sizes these systems feature cooler, high flow electric fan and thermal sensing switch in one, easy to install package.

The small system is 10" x 7-1/2" x 4" and the large system measures 13-1/2" x 9" x 3-1/2"

P/N

94-006P	B&M Supercooler (Polished)
94-006	B&M Trans Cooler (Black)
94-007	Trans Cooler system (large)



94-006P



94-007

Meziere Water Pumps & Reservoir Pumps



Standard SBC/BBC water pump design will clear Jessel belt drives and comparable belt drive systems. Spacers will be necessary to clear belt drive distributor systems. Supplied complete with gaskets and hardware but without the inlet fitting. The fitting needs to be ordered according to the size of the lower radiator hose. Under normal use the pump will draw 6-7 amps. When purchasing a pump for a 16 volt system we recommend the 16 volt optional motor on our pump. The 12 volt pump will work for limited use applications.

Reservoir Pumps are a cure for the problems associated with low and horizontal mounted radiators. 200 series pumps have a built in expansion tank that serves as a fill point and air separator. Returning the pressure cap to the suction side of the system allows you to fill the system easily with the pump running and maintains the level by purging accumulated air before any water escapes. With a head of water above a self priming pump cavity, this design eliminates air locking and cavitation.

P/N

85-WP100U	BB Chev, polished
85-WP173U	94-up 5.0 & 5.8 Ford, polished
85-WP200U	BB Chev, reservoir, polished
85-WP201U	SB Chev, reservoir, polished
85-WP1125U	Radiator hose fitting, 1-1/4" hose
85-WP1150U	Radiator hose fitting, 1-1/2" hose
85-WP1175U	Radiator hose fitting, 1-3/4" hose
85-WP1012U	#12 AN hose fitting
85-WN0912U	#12 AN Chevy manifold outlet plate



85-WN0912-U



85-WP1175U



85-WP1012U



85-WP200U

PRP Water Pumps

PRP Electric Water Pumps are made of a full billet construction with a heavy duty motor - 50gpm. Remote mounted in-line electric water pumps also available!

P/N

85-6600	SB Chevy
85-6625	BB Chevy
85-6655	Billet In-Line Remote Mount (6 lbs.)



85-6600 & 85-6625



85-6655



ASK Us About PRP FINISH Options



CO₂ Bottles & Regulators

A spare air bottle is cheap insurance against being caught "empty" handed. All S&W CO₂ bottles meet DOT regulations. Two style air pressure regulators are available; a 150lb. preset regulator is used on all S&W Lenco equipped funny cars and a fully adjustable, dual gauge regulator is available for air shifter and throttle stop use.

The trick new way to carry & store your spare, 3/4# air bottle. This bracket holds your bottle secure during towing and can be mounted low, away from the heat. Available to hold two or three, 3/4 # air bottles



95-8232

P/N

- 70-055K 3/4lb. CO₂ bottle kit (bottle, dual regulator & lines)
- 70-055 3/4lb. CO₂ bottle (uses 95-8228 bottle clamp)
- 70-056 2-1/2lb. CO₂ bottle (uses 95-8224 bottle clamp)
- 70-058 Dual gauge regulator
- 70-066 80# Preset Single Gauge
- 70-067 150lb. preset regulator
- 70-068 250lb. preset regulator
- 95-8231 Trailer rack - holds two 3/4# bottles (not included)
- 95-8232 Trailer rack - holds three 3/4# bottles (not included)

Aluminum Bottle Clamps

These trick, billet aluminum bottle clamps are just the ticket for air, nitrous or fire bottle mounting. Sold in pairs only. Tube Mount Shown. Flat Mount Avail.

P/N

- 95-8212 fits 4.5" dia. bottles
- 95-8213 fits 4.25" dia fire bottles
- 95-8214 fits 6.875" dia. bottles
- 95-8215 fits 4.5625" dia. "fresh air" bottles
- 95-8220 fits 5.10" dia. bottles
- 95-8222 fits 4.0" dia. bottles
- 95-8224 fits 4.375" dia. bottles
- 95-8225 fits 5.25" dia. bottles
- 95-8226 fits 4-3/8" dia. bottles, notched
- 95-8228 fits 2.0" dia. bottles
- 95-8229 fits 3.25" dia. 1.5# CO₂ bottles
- 95-8233 fits 4.25" dia. Accusump bottles
- 95-8234 Dual Bottle Bracket Kit 6-7/8" dia. NOS & 2" dia. CO₂
- 95-8245 fits 4-3/8" Diam. Bottle to 1-5/8" Diam. Tube
- 95-8246 fits 2" Diam. Bottle to 1-5/8" Diam. Tube
- 95-8247 fits 5-1/4" Diam. Bottle to 1-5/8" Diam. Tube



95-8212



95-8234



95-8246



95-8245
95-8247

Throttle Controls

Biondo Racing has developed the new "Precision Control" (part # 95-941) throttle control to help you achieve the ultimate in consistency.

P/N

- 95-936 BRP standard throttle control
- 95-937 BRP progressive throttle control
- 95-941 BRP precision throttle control - short version
- 95-942 BRP 2 position throttle control



95-937



95-936

Longacre Computer Scales

Two separate scale systems have been developed for the drag race market. The first is the "E" scale system. This system shows all 4 wheels and any % at the same time on large, easy to read displays. Scale memory holds 4 chassis set ups with easy recall. Each "E" series system comes in a heavy-duty carrying case and utilizes Longacre's H.D. yellow cables and smooth top, low profile pads. The "DX" features an Intel computer microprocessor with 10 set up memory with 1 button recall, Autolevel, which electronically compensates for the differences between your shop and the track, and Center of Gravity computations. 2 year limited warranties.

P/N

- 95-72608 Longacre, "E" series scale system
- 95-72634 Longacre, "DX" series scale system



72634

AIR PUMP System

Replace your existing CO₂ System with K&R's new Air Pump System. Small enough to mount in battery tray or nose of most dragsters •Measures only (10.5"L x 6.5"W x 8"H) •Light Weight •Controls all your current pneumatics (throttle stops, air shifters, starting line controls, etc.) •Low current High psi 12v Air Pump •"Self-contained" air reservoir tank with moisture purge/fill valve •Adjustable regulator w/gauge for consistent line pressure from 0-100psi •Built-in pressure switch •Quick connect coupler fitting for airing tires-Never carry an air tank again! •Supplied Stretch Hose w/tire chuck •Includes mounting hardware, fittings, wiring, & quick disconnect w/valve •1-year warranty

- P/N 70-095 Air Pump System



Oil Accumulator Mount

S & W's new oil accumulator mount makes installing a Moroso oil accumulator or Canton Accusump neat and easy. Kits will mount the 1.5 quart accumulator over the transmission and offers quick removal for transmission service. Mounts are available to bolt in to any S&W super class dragster or in kit form (some welding required) for other manufacturer's dragsters. No plumbing is included, but S&W stocks all the necessary hose and fittings to complete the job.



P/N

- 05-161 S&W 4-link or swing arm with 1-1/4" frame rail
- 05-162 S&W "converted" 4-link with 1-3/8" frame rail
- 05-163 Unwelded kit



95-941

95-942

Oil Accumulators

Moroso Oil Accumulators provide an instantaneous supply of oil when pressure falls below a safe level. Prevents cold-start scuffing and premature bearing wear. Saves you time and money.



P/N

- 85-23901 Oil Accumulator 1.5 quart, 10" x 4-1/4"
- 85-23690 Oil Filter Plate (installs under oil filter and allows use of accumulator with small block Chevy)
- 95-8233 Oil Accumulator mount kit for 1-5/8" tube welding required

Heating Pads

Excellent for pre-heating of oil pans, tanks and automatic transmission pans. Self-adhesive attachment method. Etched foil design distributes heat evenly. Silicone outer shell resists oil and dirt



85-23997

85-23996

P/N

- 85-23996 Heating pad 5" x 7"
- 85-23997 Heating pad 2" x 15"

Seat Belts & Harnesses *sfi 16.1*

S & W stocks a complete line of S.F.I approved **STROUD, Taylor & RJS** seat belts and safety harnesses. Five point, 3" wide belts are available with quick release or latch type buckles and with bolt in or wrap around mounting attachments. Snap in belts are available by special order. Arm restraints are available for all applications. **6 Point, 7 Point & Colors other than those listed below are available by special order.**



Ask About
Nomex
Fire Proof
Covering
Options.

- P/N
75-456 Arm restraints, black
- 75-372 RJS Camlock, 5 Point Bolt-In, black (or wrap)
75-389 RJS Camlock, 5 Point Dragster Wrap, black
75-390 RJS Latch, 5 Point Bolt-In, black (or wrap)
75-714BLK TAYLOR Camlock, 5 Point Dragster Wrap, black
STROUD Stroud Seat Belts



Helmets & Helmet Skirts

RJS HELMETS SAH2015 Models

Full Face & Open Face Avail.

Gloss Black
Matte Black
Carbon Fiber

DEIST Helmet Skirt

sfi 3.3/10

E-Z Velcro Attachment



Lateral Head Support Pad System

BUTLER Lateral head support pads with hardware for Dragster or Funny Car. Complete kit to install Lateral Head Support pads. *MUST COMPLETE A MEASURING SHEET AND FAX IT TO BUTLER FOR ORDER ACCEPTANCE. (ALTERNATE MOUNTING TAB 60-401) [Please Call Us.](#)



- P/N
ADV-22131 Butler Lateral Head Support Pad System

BUTLER BEAD Seat Kit

ButlerBuilt Creafoam Bead Insert kits offer Excellent dimensional stability. Creates a molded shape of your body. SFI 45.2 approved. Excellent energy absorption. Extremely lightweight beads. (COVERS UP TO 24" SEAT / incl. 2 yards of material) [Please Call Us.](#) **POUR SEAT Kits also avail.**



- P/N
95-416 Butler Bead Seat Kit (medium)

Helmet Shroud Cockpit Shield

Helmet Shrouds / Cockpit Shields. Funny Cars, TAD and other classes as required by sanctioning body rules. Installation kits use aircraft quality fasteners to meet NHRA spec.



- P/N
76-100 Funny Car Helmet Shroud - Titanium
76-101 Funny Car Helmet Shroud Installation Kit
76-100 Dragster Helmet Shroud - Titanium
76-100 Dragster Helmet Shroud Installation Kit

Head & Neck Device/System *sfi 38.1*

7.49 or Quicker ET? You will need to wear a Sfi 38.1 Head & Neck Device/System (NHRA Rule) S&W is Your Source for the Hans Brand Devices, Tethers, Helmet Posts and Other Accessories Avail. Call for details on what's right for You!



Hans Accessories Available - Call



Neck Supports

- P/N
75-805TBK Black • Tapered neck support
STROUD Neck Supports



Fire Suits *sfi 3.2A/5 up to 3.3/20*



Safety has always been a prime concern at S & W, but safety doesn't end when your car is finished. S & W supplies driver safety apparel from multiple manufacturers. Jackets and/or Pants (S.F.I. spec. 3.2A/5) are avail. in Black, Red, Blue & custom colors avail. Not all colors and sizes may be available at all times.

CALL Your S&W Representative to discuss your needs.

Sfi 15 & 20 Suits and 1 Piece Suits are Available!

- P/N
Jacket
Sfi 3-2A/5
S,M,L,XL,2XL,3XL



Funny Car Under Body Fire Paint

See Pg. 94

- P/N
Pants
Sfi 3-2A/5
S,M,L,XL,2XL,3XL



Driver's Gloves *sfi 3.3/5*

SFI 15 & 20 Gloves Available!

- P/N
STROUD Gloves
RJS Gloves

- P/N
75-4302 Deist Glove • X Large • Black



WINDOW NETS - PARACHUTES - TRANSMISSION SHIELDS

Window Nets sfi 27.1

STROUD window nets have 1" wide webbing with loops at the top and bottom to accommodate mounting rods. The NEW S & W Quick latch window net mounting kit features a quick release latch that is easily operated even with the driver belted into the seat. Kit is designed to allow the net to drop out of the way to allow easy entrance and exit from the race car. Necessary hardware is included.



75-387R



- P/N
75-361 18" x 24" Black window net
75-387 Window Net Mount Kit Quick Latch
75-387R Window Net Top Rod Upgrade Kit Quick Latch

Parachutes & Accessories



Whether you're slowing down a bracket car or a top fueler, S & W has a chute that meets your needs. In addition to parachutes S & W also stocks pilot chutes, chute packs and accessories. Most chutes are available in red, blue and black. Please call for colors and availability.

Parachutes

- STROUD Parachutes, Spring launcher & Air Launcher Systems - Call
75-213BLACK Stroud - 12' - SG/SC - black
75-708BLACK Taylor - 10' - Sportsman dragsters & roadsters - black only, chrome pack.

Parachute Accessories & Mounting Kits

- STROUD Parachute Accessories - Call
05-065 Solid Dragster Parachute/anti-rotation device mount
05-067 4-Link Dragster Parachute/anti-rotation device mount
70-468 Chute Release Cable 168" Black casing
75-118 Release clip for chute pack 3/8" Cable
75-119 Release clip for chute pack 1/4" Cable
75-144 Doorslammer chute release kit with cable
75-146 Dragster or Altered chute release kit with cable
75-147 Doorslammer Parachute mount & anchor (Note: Welding Req'd, Unassembled & Unpainted)
75-147CM Doorslammer Parachute mount & anchor - Chrome Moly (same note as 75-147)
95-5521 Replacement release handle
95-017 Chute Tether (IF USING 2 CHUTES, MUST BE PURCHASED IN PAIRS)
75-118 Cable Release Clip Kit for 3/8" cable jacket size
75-119 Cable Release Clip Kit for 1/4" cable jacket size
75-107 Parachute Handle Kit
75-1995 Single Parachute Mount Kit (Note: Welding Req'd, Unassembled & Unpainted)



75-1995

Kit is Shipped Bare and Unwelded



75-1995
Shown Welded

Flexplate Shields & Transmission Shields

S & W safety shields are designed to fit without clearance problems and provide maximum protection in the event of a transmission or flexplate failure. The S & W transmission shield is made of 1/4" thick 6061-T6 aluminum and is anodized blue or red for a neat appearance. All shields come complete with mounting hardware and have a current S.F.I. sticker attached.

- P/N
95-3410BLK Powerglide - black
95-3415Black Turbo 400 - black
95-3416B Turbo 350 - blue

Custom Window Nets sfi

STROUD Custom Window Nets Feature: 1" Nylon Webbing with a Box stitch pattern - 2" Box - Individual Loop Mount - Sfi 27.1 Rating - Colors: Black, Red, Blue, Purple, Pink, Green & Brown. Sold ea. - Up to 4 sq. ft.

Must Complete Diagram with Measurements on the Product Instructions Page of our WebSite www.swracecars.com

- P/N
75-371 Custom Size Window Net

Custom Wheelie Bar Nets

Custom Wheelie Bar Nets Feature: 1" Nylon Webbing with a Box stitch pattern - 3" Box - Adjuster Bar Mount or Grommet Mount - Colors: Black, Red, Blue, Purple, Pink, Green & Brown. Sold ea. - Up to 9 sq. ft. **Must Complete Diagram with Measurements on the Product Instructions Page of our WebSite.**

- P/N
75-372 Custom Wheelie Bar Net

Custom Door Nets sfi

P/N
75-378 Custom Size Door Net
Must Complete Diagram as stated above



75-118 / 75-119



75-147

Kit is Shipped Bare and Unwelded



75-147 Shown
Welded and
Painted



Click to View
the Window Net Mount
Quick latch
Demonstration
Video



75-213
SG/SC
Black
Chute



75-107



75-144

Doorslammer
chute release
kit with cable



COMBO Kit #1
See Pg.13 for
the complete list
of D-I-Y
'Kits that Fit'



95-3410



95-3415



75-4903



ENGINE DIAPERS - TRANNY BLANKETS - FIRE SYSTEMS - BELLY PANS

Engine Diapers **SFI 7.2** **STROUD**

SFI 7.2 certified engine diaper. Made of heavy duty ballistic inner material with nylon outer material. Designed to be light, flexible and strong. Includes snap-in absorbant pads and quick release mounting hardware.

P/N

- 75-226 BB/SB Universal - NO SFI - 'NHRA/IHRA Accepted' eng. diaper
- 75-221 Big Block Chevy - SFI 7.2 certified engine diaper Header Mount.
- 75-221C Big Block Chevy - custom fit SFI 7.2 certified engine diaper
- Contact S&W or refer to our website for order sheet
- 75-222 Small Block Chevy - SFI 7.2 certified engine diaper
- 75-225 Recertification Service for BBC - SFI 7.2 diaper
- STROUD STROUD Diapers



75-226

Transmission Blankets **SFI 4.1**

These blankets are multilayer, water and oil resistant nylon with heavy duty adjustable straps. Blankets for automatic transmissions are available in 12" or 16" widths. Lenco blankets are available in 2 and 3 speed configurations. S.F.I. approved.

P/N

STROUD Blankets

- 75-502 Lenco 2 speed with reverse
- 75-503 Lenco 3 speed with reverse
- 75-512 12" Universal for automatic transmissions
- 75-516 16" Universal for automatic transmissions



Fire Systems **STROUD**

P/N

- 75-216 5lb. Safety Fire System
- 75-216R 5lb. Safety Replacement Cartridge
- 75-217 Mounting brackets for 5 lb System (Pair Req'd. for proper mounting)
- 75-218 Mounting brackets for 10 lb System (Pair Req'd. for proper mounting)
- 75-357R Recharge service for 10lb bottle
- STROUD Complete Systems



Protective 'Fire Paint' for Funny Cars (See FC Section Pg.94/95)

DOOR CAR SEATS & SEAT MOUNTS

Aluminum Drag Seat

Jaz seat features aluminum extrusion welded to perimeter of seat for extra strength. Extra wide shoulder harness slot allows for easier belt installation. Seat is fully TIG welded. Made of .100" 5052 aluminum. Properly designed kick up in bottom assures driver comfort. Seat cover & mount kit sold separately. High Impact Seat Foam also Avail.

P/N

- 95-385 Aluminum seat
- 95-386 Black cover for aluminum seat

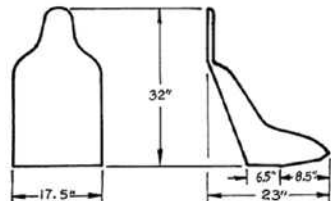

Aluminum Seat Mount Kits

S&W now has two kits designed to ease the installation of the JAZ aluminum seat shown above. A bolt in kit for applications with a flat stock floor and a weld in version for custom application or vehicles where a flat floor is not present.

P/N

- 95-379 Seat mount kit, bolt in
- 95-380 Seat mount kit, weld in



95-380 (shown)

95-379 (shown)

Poly Seat Mount

This lightweight, aluminum seat mount fits all popular "poly" seats now being sold on the market. This kit is designed to easily adapt these popular seat to any vehicle retaining the stock floor. Each kit does one seat.



P/N

- 95-383 Mounting kit for stock floors

Seat Back Support

Our unique, seat back support is fully adjustable and easily installs on either poly or aluminum seats. Kit features zinc plated components and grade 8 hardware. Welding required.



P/N

- 95-384 Adj. seat back brace

KEVLAR TURBO BLANKETS



Sfi 4.1 Turbo Blankets are custom made to your spec's. In the USA! CALL for Info.

See Page 69 for Complete Selection of Aluminum Bottle Clamps



Belly Pan Kits

Tired of fighting with heavy, hard to install engine diapers on your car? Then S&W's Belly Pan kits are what you need! Made of .050" aluminum the pan measures 18-1/2" wide at front x 17-3/4" wide at rear x 28" long. Front and side walls are 4" high and Rear wall is 6" High. Walls can be easily trimmed to clear your accessories while maintaining the required 2" height. Kit includes 6 mounting tabs (Weld-On or Clamp-On) and all necessary quarter-turn fasteners for installation. Pans have a bare aluminum finish. Absorbant pads sold separately (2 pads required.)



05-175



05-171



CUSTOM BELLY PANS are a S&W Specialty!!
Send Us Your Drawing for a Quote.

P/N

- 05-171 Dragster Weld-On Belly Pan Kit
- 05-175 Dragster Clamp-On Belly Pan Kit
- 07-025 Roadster Belly Pan
- 05-171-03 Absorbant pads (each)

TRAILER/TOWING ACCESSORIES - TIRE & TEMP GAUGES

Chassis Stabilizer

SPECIFICATIONS:

Diameter: 18"
Height: 1.75" -10" (NO LOAD)

P/N
95-035
Chassis stabilizer



Racing Tire Gauges

S&W tire gauges are available in a variety of gauge sizes and maximum pressure ranges. Each gauge is designed to hold the pressure until you push the release button. Some gauges feature "glow in the dark" which makes night readings a snap! A handy, padded carrying pouch is also available separately.

Wheel Cradles

The Wheel Cradle is a 5 wide, 3-1/2 tall, 22 long, all rubber product that holds 17 dragster front wheels stable during transportation. This is a must for overall chassis stability during transportation. Most chassis builders recommend not tying the front of the car to the trailer floor during transportation. Sold in Pairs

P/N
95-037 Wheel cradle - pair



Tie-Downs

Tie downs come in a variety of lengths and load ratings. These quick release, ratchet type tie downs are available with either frame or over-tire attachment mounts. Exposure to weather can ruin your tie downs, check them regularly and replace them before they fail!!

P/N
75-754 14" Attachment strap
75-757 Tire tie down, in-line ratchet, 8'
75-380 2" x 6ft w/ Twist Snap Hks. 10K rating
75-381 2" x 8ft w/ Twist Snap Hks. 10K rating
75-382 2" x 10ft w/ Twist Snap Hks. 10K rating

75-380
(shown)



P/N
95-50518 Padded tire gauge pouch
95-52034 Longacre gauge, 2", glow in the dark, 0-15 lbs.
95-52024 Longacre gauge, 2", glow in the dark, 0-30 lbs.
95-52033 Longacre gauge, 2-1/2", glow in the dark, 0-15 lbs.
95-50422 Longacre gauge, 2-1/2", glow in the dark, 0-30 lbs.
95-52003 Longacre gauge, 2-1/2", glow in the dark, 0-60 lbs.
95-5045 Longacre gauge, 2", standard face, 0-15 lbs.
95-5042 Longacre gauge, 2", standard face, 0-30 lbs.
95-89550 Moroso gauge, 2-1/2", 0-15 lbs.
95-89560 Moroso gauge, 2-1/2", 0-60 lbs.
95-89574 Moroso Digital gauge, Backlit, 0-15 lbs.

Longacre Pyrometers

Longacre Infrared, non-contact pyrometers feature instant response and are great for recording brake and header temperature as well as hot spots in the trans case rear housing or oil pan temperature. Of course they're great at recording starting line temperatures. A must for the serious racer. Two models are available.

P/N
85-50614 Pyrometer 1000 deg (storage pouch included)
85-50612 Mini Pyrometer 500 deg.



ISC RAGERS TAPE - DIAL IN MARKER - WAX & POLISH

Standard Duty Tape

P/N
96-RT2001 SDT Red
96-RT2002 SDT Blue
96-RT2003 SDT Yellow
96-RT2004 SDT Black
96-RT2006 SDT White
96-RT2007N SDT Neon Green
96-RT2008 SDT Orange
96-RT2008N SDT Neon Orange



Checkerboard Tape

P/N 96-RT5001 Checkerboard tape

Xtreme Duty Tape

This highly aggressive and heavy tape will succeed where other tapes fail.

P/N 96-RT4004 Xtreme Duty Tape - Black

Leading Edge Tape

A transparent polyurethane protective tape that is exceptionally tough, offers abrasion protection and has excellent non-yellowing UV resistance.

Non-Skid Tape

P/N 96-RT8014 2" x 10' roll
96-RT8016 4" x 10' roll



USA Auto Supply Philadelphia Paint, Auto Body & Car Care Products

S&W is a Distributor of all USA Auto Supply Philadelphia Products. Please call.

Dial-In Marker

Dial-In Marker wipes off with dry rag. Stain free on Lexan. Safe on paint.

P/N 95-026 Dial-In Marker

BUTTONS, BUNGS, CAPS, CLEVIS, Q-PINS & TUBE ENDS

S & W stocks a complete line of high strength, aircraft quality fasteners. When it comes to holding your race car together don't settle for anything but the best. In stock are grade 5 and grade 8 hex head bolts in all standard diameters and lengths. Also available are high quality hex and jam nuts, Nylock hex nuts and Nylock half-nuts. Flat washers and lock washers are available in all standard sizes. For those small jobs S & W stocks stainless steel Phillips-Panhead and stainless steel, Phillips-Countersunk screws in sizes 6-32, 8-32 & 10-32 in a variety of lengths. Nylock hex nuts and AN flat washers are available in these sizes. Please call for prices. Quantity discounts available.



Weld-In Clevis Ends

These clevis ends can be used for a variety of suspension, steering or other linkages.



P/N

- 64-811 3/8" slot, 1/2" x 3/4"
- 63-052 1/8" slot & 1/4" hole fits 5/8" x .058" wall tubing
- 63-053 3/16" slot & 5/16" hole fits 3/4" x .058" wall tubing
- 63-056 1/4" slot & 3/8" hole fits 1" x .095" wall tubing
- 63-057 1/4" slot & 3/8" hole fits 1-1/8" x .058" wall tubing
- 63-068 1/8" slot & 3/16" hole fits 3/8" x .058" wall tubing
- 63-067 10-32 Threaded Clevis
- 63-066 Male Clevis 5/16" hole, 3/16" tab, 2-1/2" long
- 63-060 Threaded Clevis 5/8"-18, 3/8" slot, 3/8" hole
- 63-064 Threaded Track Bar Clevis 5/8" x 7/16"

Threaded Tube Ends

These threaded tube ends are ideal for a variety of uses where a threaded end is required in thin wall tubing.

P/N

- 63-078 1/4"-28 thread for 5/8" x .058" wall tubing
- 63-080 3/8"-24 thread for 3/4" x .058" wall tubing
- 63-081 3/8"-24 LH thread for 3/4" x .058" wall tubing with integral adjusting hex
- 63-082 7/16"-20 thread for 3/4" x .058" wall tubing
- 63-083 7/16"-20 LH thread for 3/4" x .058" wall tubing
- 63-086 3/8"-24 thread for 7/8" x .058" wall tubing
- 63-087 3/8"-24 LH thread for 7/8" x .058" wall tubing
- 63-088 7/16"-20 thread for 7/8" x .058" wall tubing
- 63-090 1/2"-20 thread for 7/8" x .065" wall tubing
- 63-091 1/2"-20 LH thread for 7/8" x .065" wall tubing with integral adjusting hex
- 63-092 5/16"-24 thread for 5/8" x .058" wall tubing
- 63-093 5/16"-24 LH thread for 5/8" x .058" wall tubing
- 63-114 5/8"-18 RH thread for 1-1/4" x .083" wall tubing
- 63-100 10-32 thread for 3/8" x .058" wall tubing
- 63-103 1/2" x 7/8" x .083" wall tubing
- 63-104 5/8"-18 RH thread for 1-1/4" x .095" wall tubing
- 63-105 5/8"-18 LH thread for 1-1/4" x .095" wall tubing
- 63-110 3/4"-16 RH thread for 1-1/4" x .065 wall tubing
- 63-111 3/4"-16 LH thread for 1-1/4" x .065 wall tubing
- 63-112 5/8"-18 RH thread for 1-1/8" x .058" wall tubing
- 63-112LH 5/8"-18 LH thread for 1-1/8" x .058" wall tubing
- 63-113 1/2"-20 LH thread for 7/8" x .083" wall tubing
- 63-115 5/8"-18 LH thread for 1-1/8" x .083" wall tubing
- 63-118 1/2"-20 RH thread for 1" x .095" wall tubing
- 63-119 1/2"-20 LH thread for 1" x .095" wall tubing
- 63-122 3/8"-24 RH thread for 1" x .095" wall tubing
- 63-123 3/8"-24 LH thread for 1" x .095" wall tubing
- 63-101 3/8"-24 RH thread for 7/8" X .058" wall tubing
- 63-094 1/2"-20 RH thread for 1-1/4" X .065" wall tubing
- 63-128 1/2"-20 RH thread for 1" X .065" wall tubing



63-108
MALE
Threaded
Tube End
5/8 - 18
FITS
1-1/8 X .058
TUBING

Threaded Tube Ends for 4-Link Applications

Custom CNC machined from 4130 steel, these threaded tube ends are the "hot setup" for custom 4-link applications. Available for 1-1/4" or 1-3/8" x .095" tubing, the left hand versions have a large hex nut machined into the surface for easy adjusting of your 4-link.

P/N

- 63-095 3/4"-16 RH thread for 1-3/8" x .095 wall tubing
- 63-096 3/4"-16 LH thread for 1-3/8" x .095 wall tubing
- 63-098 3/4"-16 RH thread for 1-1/4" x .095 wall tubing
- 63-099 3/4"-16 LH thread for 1-1/4" x .095 wall tubing



Quick Pins

These handy pins are designed to replace nuts and bolts where frequent assembly and disassembly occurs. Ideal for use in your trailer as well as your race car. Each pin features a positive locking ball which requires a push of a button to release. Can not be pulled out or fall out accidentally.



P/N

- 66-001 1/4" x 1"
- 66-002 1/4" x 1-1/2"
- 66-003 1/4" x 2"
- 66-004 5/16" x 1"
- 66-023 5/16" x 1-1/4"
- 66-006 5/16" x 2"
- 40-3126 3/8" x 2-1/2" for use with Wheelie Bars
- 66-007 5/16" x 3"
- 66-008 3/8" x 1"
- 66-010 3/8" x 2"
- 66-012 3/8" x 3"
- 66-021 1/2" x 2-1/2"
- 66-069 Detent pin 3/16" shank x 3/8" grip



63-069

Aluminum Weld Bungs

Manufactured from 6061 aluminum, S&W weld bungs feature an extra thick lip to prevent distortion of the internal threads during the welding process. S&W weld bungs accept flare unions in a variety of sizes and are perfect for use in fuel, oil or water tanks.



P/N

- 94-AN871-04D #4 Aluminum weld bung - female
- 94-4009 #6 Aluminum weld bung - female
- 94-4010 #8 Aluminum weld bung - female
- 94-4011 #10 Aluminum weld bung - female
- 94-4012 #12 Aluminum weld bung - female
- 94-4013 #16 Aluminum weld bung - female
- 94-AN971-04D #4 Aluminum weld bung - male
- 94-8096 #6 Aluminum weld bung - male
- 94-8104 #8 Aluminum weld bung - male
- 94-8107 #10 Aluminum weld bung - male
- 94-8117 #12 Aluminum weld bung - male
- 94-8127 #16 Aluminum weld bung - male
- 94-8130 #20 Aluminum weld bung - male

Filler Caps & Drains

Useful for a variety of projects, these handy caps and weld bungs are primarily used as fuel tank and rear housing fill caps. Fuel cap is aluminum with aluminum bung, rear cap is aluminum with steel bung.

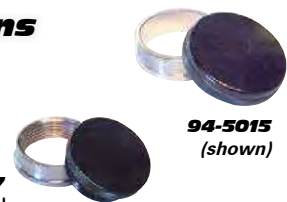

94-5015 (shown)

94-5017 (shown)

P/N

- 94-5015 Fuel tank cap & bung
- 94-5016 Rear drain plug & bung
- 94-5017 Rear filler cap & steel bung
- 94-5018 Rear filler cap & aluminum bung

94-5016 (shown)

Hatch Buttons & Latches

Three, trick little button type latches are available through S&W. The first is the same used on the roof hatch of all S&W funny cars, the second is a similar button with an extended "arm" which is used to secure the door windows on doorslammers. The final latch is the rectangular latch used on S&W fuel tank doors and hinged access panels.



95-313 (shown)

95-301 (shown)

95-302 (shown)

P/N

- 95-300 F/C hatch buttons - pair
- 95-301 F/C hatch button - single
- 95-302 Fuel Door Latch or computer - single
- 95-313 Window latch button - single

Motor Mount/Chassis Clamps

Stainless steel t-band clamps, designed for use where standard automotive clamps are unacceptable.



P/N

- 20-109 1-1/4" clamp-fits S&W dragsters
- 20-109A 1-1/2" clamp-fits S&W altered & funny cars
- 20-TB213 2-1/8" - 2-7/16" universal clamp



ROD ENDS & Accessories

S&W stocks sizes from 3/16" to 3/4" with male or female threaded ends. ID of the ball is the same as thread diameter, except when noted. Chrome-moly rod ends are also available for high load applications. Teflon lined rod ends are available for street applications where normal rod end noise is unacceptable. Solid rod ends are designed to replace the spherical rod ends used on the rear of some ladder bars. Solid rod ends eliminate the lateral movement of the rear housing commonly found when spherical rod ends are used. Jam nuts not included, see below.

P/N

- 40-234 ■ 3/4" x 3/4" Solid rod end
- 40-235 ■ 3/4" x 5/8" Solid rod end
- 64-103 3/16" R/H male - standard - 3 piece
- 64-104 1/4" R/H male - standard - 3 piece
- 64-105 5/16" R/H male - standard - 3 piece
- 64-106 3/8" R/H male - standard - 3 piece
- 64-107 7/16" R/H male - standard - 3 piece
- 64-108 1/2" R/H male - standard - 2 piece
- 64-109 3/16" L/H male - standard - 2 piece
- 64-108T 1/2" R/H male - standard - 2 piece - Teflon lined
- 64-110 5/8" R/H male - standard - 2 piece
- 64-112 3/4" R/H male - standard - 2 piece
- 64-112T 3/4" R/H male - standard - 2 piece - Teflon lined
- 64-305 5/16" L/H male - standard - 3 piece
- 64-306 3/8" L/H male - standard - 3 piece
- 64-307 7/16" L/H male - standard - 3 piece
- 64-308 1/2" L/H male - standard - 2 piece
- 64-308T 1/2" L/H male - standard - 2 piece - Teflon lined
- 64-310 5/8" L/H male - standard - 2 piece
- 64-312 3/4" L/H male - standard - 2 piece
- 64-503 3/16" R/H female - standard - 3 piece
- 64-504 1/4" R/H female - standard - 3 piece
- 64-505 5/16" R/H female - standard - 3 piece
- 64-506 3/8" R/H female - standard - 3 piece
- 64-507 7/16" R/H female - standard - 3 piece
- 64-508 1/2" R/H female - standard - 3 piece
- 64-509 5/8" R/H female - standard - 3 piece
- 64-612 3/4" R/H male, 5/8" bore - standard - 2 piece
- 64-612T 3/4" R/H male, 5/8" bore - standard - 2 piece, Teflon lined
- 64-613 3/4" L/H male, 5/8" bore - standard - 2 piece
- 64-206 3/8" R/H male - chrome moly - 3 piece
- 64-207 7/16" R/H male - chrome moly - 3 piece
- 64-208 1/2" R/H male - chrome moly - 3 piece
- 64-210 5/8" R/H male - chrome moly - 3 piece
- 64-211 5/8" L/H male - chrome moly - 3 piece
- 64-212 3/4" R/H male - chrome moly - 3 piece
- 64-406 3/8" L/H male - chrome moly - 3 piece
- 64-408 1/2" L/H male - chrome moly - 3 piece
- 64-412 3/4" L/H male - chrome moly - 3 piece
- 64-607 7/16" R/H male, 3/8" bore - chrome moly-3 piece
- 64-608 5/8" R/H male, 1/2" bore - mild steel -3 piece
- 64-610 3/4" R/H male, 5/8" bore - chrome moly-3 piece
- 64-610T 3/4" R/H male, 5/8" bore - chrome moly-3 piece-Teflon lined
- 64-611 3/4" R/H male, 1/2" bore - chrome moly-3 piece
- 64-712 3/4" R/H male, 5/8" bore - chrome moly-2 piece
- 64-808 5/8" L/H male, 1/2" bore - mild steel -3 piece
- 64-810 3/4" L/H male, 5/8" bore - chrome moly-3 piece
- 64-810T 3/4" L/H male, 5/8" bore - chrome moly-3 piece-Teflon lined
- 64-812 3/4" L/H male, 1/2" bore - chrome moly-3 piece
- 64-816 5/8" R/H male, 1/2" bore - chrome moly-3 piece
- 64-817 5/8" L/H male, 1/2" bore - chrome moly-3 piece

Rod End Jam Nuts

Don't forget to replace the jam nuts when you change rod ends. Constant tightening will eventually wear the flats on the jam nuts and new nuts are cheap insurance against skinned knuckles by reducing the chance of the wrench slipping. Sold each.

- | | |
|-------------------------|-------------------------|
| 65-508 3/16" RH jam nut | 65-115 7/16" LH jam nut |
| 65-110 1/4" RH jam nut | 65-116 1/2" RH jam nut |
| 65-111 5/16" RH jam nut | 65-117 1/2" LH jam nut |
| 65-124 5/16" LH jam nut | 65-118 5/8" RH jam nut |
| 65-112 3/8" RH jam nut | 65-119 5/8" LH jam nut |
| 65-113 3/8" LH jam nut | 65-120 3/4" RH jam nut |
| 65-114 7/16" RH jam nut | 65-121 3/4" LH jam nut |

Misalignment Bushings & Sleeves

Commonly referred to as "half moons", these bushings assure full travel of spherical rod ends without binding. Zinc plated for a more attractive appearance these bushings are resistant to wear & rust. * Sleeves are a quick & easy way to step-down your Rod End Hole size.

- 63-070 ■ 1/2" bore misalignment bushing
- 63-071 ■ 3/8" bore misalignment bushing
- 63-073 ■ 7/16" bore misalignment bushing
- 63-074 ■ 1/2" bore misalignment bushing
- 63-075 ■ 5/8" bore misalignment bushing (.150" thick)
- 63-076 ■ 5/8" bore misalignment bushing (.212" thick)
- 63-077 ■ 3/4" bore misalignment bushing
- 63-079 1/2" bore misalignment bushing (.212" thick x 1"OD)
- 64-100 3/4" OD x .058 wall x 7/8" LG Rod End Sleeve
- 64-101 5/8" OD x .058 wall x 7/8" LG Rod End Sleeve

1/4 TURN FASTENERS & Accessories

Seals-It Rod End Seals

Seals-it rod end seals offer protection from dirt or other contaminants that can greatly reduce the life of expensive rod ends due to excessive wear. Seals-it rod end seals feature a neoprene rubber seal that is permanently bonded to an aircraft quality washer, creating a seal that completely covers the bearing area of any rod end yet is flexible enough to maintain it's seal during changes in angularity.



P/N

- 64-900 5/16" Rod end seal
- 64-901 3/8" Rod end seal
- 64-902 7/16" Rod end seal
- 64-903 1/2" Rod end seal
- 64-904 5/8" Rod end seal
- 64-905 3/4" Rod end seal

Quarter Turn Fasteners

Slotted quarter-turn fasteners are designed for the quick assembly and disassembly of sheet metal or fiberglass panels. Quantity discounts are available.

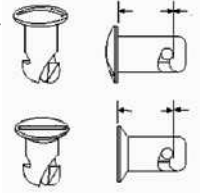

Measuring Body Length

- 65-900 Short button - .400 body
- 65-901 ■ Long button - .600 body
- 65-902 ■ Medium button - .500 body
- 65-904 ■ Shallow spring - .275 height
- 65-906 ■ Deep spring - .325 height
- 65-908 ■ Spring plate - standard
- 65-909 ■ Spring plate - lightweight
- 65-910 ■ Short ejector button - .400 body
- 65-911 ■ Long ejector button - .600 body
- 65-912 ■ Medium ejector button - .500 body
- 65-915 ■ Medium winged ejector button - .500 body
- 65-916 ■ Long winged ejector button - .600 body
- 65-917 ■ Pro/Stock button - ejector - .500 body
- 65-919 ■ Pro/Stock button - winged ejector - .500 body
- 65-921 ■ Oval head short button - .500 body
- 65-923 ■ Oval head medium button - .550 body
- 65-924 ■ Oval head long button - .600 body
- 65-920 ■ Panel reinforcing plates w/Holes (1.75" OD)
- 65-922 ■ Panel dimple tool
- 65-925 ■ Teflon button washers (package of 25)
- 65-928 Button Reinforcing Plate w/o Holes (1.25" OD)
- 65-928R Button Reinforcing Plate w/Holes (1.25" OD)
- 65-929 ■ Button Backing Plate w/Holes (for 65-917 type)
- 65-940 ■ Oval Head .400 button body

SAVE MONEY Purchase Bulk

- 65-930 7/16" ejector button .550"
- 65-933 Quarter-turn button driver
- 65-937 7/16" ejector button .600"
- 65-939 ■ Pro/Stock Oval Head button - .500 body
- 65-960 ■ Hood mounting kit - slotted
- 65-961 ■ Hood mounting kit - winged
- 65-962 Deck mounting kit - slotted
- 65-963 Deck mounting kit - winged
- 65-370 Spring plate - 2" w x 5.5" long, 3/4" hole fits 65-917 button
- 65-970 5/16" Black Oval Head .450"
- 65-971 1" Steel Spring .350"
- 65-972 5/16" Black Oval Head .500"
- 65-908XL Extra Long Spring Plate - 5.5" Cline of hole to end of plate



40-235 (shown)



65-933

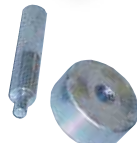

65-922



65-904



65-370



65-908XL



65-900 65-901 65-910 65-911 65-915 65-916



65-908 65-909 65-928 65-928R



TIRES & WHEELS

**SANDER ENGINEERING
DRAG RACE WHEELS**



S&W is a Sander Wheel Dealer.
Drag Racing & Sprint Car. Call us
TOLL FREE @ 1-800-523-3353 for
current pricing and shipping.



**Hayden
ENTERPRISES
SPECIALTY WHEELS**

WHEEL
SPACERS
Pg.83

90-222
Spoke Wheel
Light Shield



P/N

90-030 Polished Alum (SPE Hub Only)

90-031 Chromed Steel (Flange & SPE)

Note: Sold as Pair of (2) Wheels - Call to Order

RACE TIRES

S&W Race Cars is one of the East Coast's largest supplier of Hoosier street and drag race tires, and M/T race & street tires. Whether you need rear tires, front tires or tubes, call us for the best price. Innova dragster front tires and tubes also avail. Sold each.

P/N

- 90-131 Dragster front tire each
- 90-136 Dragster front tube each
- 1445 Goodyear dragster front tire each
- 18108F Hoosier dragster front tire each
- 90-233 Lug Nuts - 1/2", RH Open End w/Centered Washers, Pkg of 5

**MICKY THOMPSON
M/T
TIRES & WHEELS**

Hoosier
RACING TIRE

Tire Screw Templates

- 90-013 Tire Screw Template w/S&W Logo
- 90-013H Tire Screw Template w/Hoosier Logo
- 90-235 Tires Screws (35) and drill bit



FUEL SYSTEMS - FUEL CELLS, JUGS, FUNNELS & ACCESSORIES

Fuel Cells & Components

Jaz fuel cells feature rotationally molded, one-piece, 100% seamless construction. All cells have a flush mount filler cap with a one way check valve. Replacement foam kits and mounting strap kits are also available.

P/N

- 06-010 Mount tray for 80-018 dragster cell
- 80-003 3 gallon upright with foam
- 80-005 5 gallon with foam
- 80-012 12 gallon with GM fuel level sender and foam
- 80-016 16 gallon with GM fuel level sender and foam
- 80-018 4 gallon with foam - Dragster type
- 80-019 3 gallon with foam - Dragster type
- 80-020 3 gallon with foam - Dragster with extended neck
- 80-105 Mounting strap kit for 5 gallon
- 80-112 Mounting strap kit for 12 gallon
- 80-116 Mounting strap kit for 16 gallon

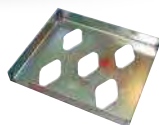

06-010



80-016



80-019



80-003



80-018



Jugs & Funnels

VP Fuels 5 gallon jugs feature an "O" ring seal in the cap and a screw on vent in the handle. Jugs feature an ergonomically contoured handle and bottom grip for easy pouring. Funnel are available in 4 popular sizes - 14" & 16" triangular and 8" & 11" round. Each funnel features an anti-splash ring and a 60 micron filter is available for all but the 8" round. Deluxe Fill Hose a must!

P/N

- 95-808Natural 5 gallon jug, Natural
- 95-808Red 5 gallon jug, Red
- 95-809 5 gallon jug, Blue
- 95-810 14" Triangular Funnel
- 95-811 16" Triangular Funnel
- 95-812 8" Round Funnel
- 95-813 11" Round Funnel
- 95-815 Funnel Filter (does not fit 85-812)
- 95-818 Deluxe Fill Hose
- 95-808PINK PINK 5 gallon jug

Aeromotive & PRP Fuel System Components

P/N

AEROMOTIVE Products
PRP Products



94-400



94-280



94-281



95-818



94-405 & 94-406



95-8227



94-404



ASK ABOUT CAMO & Other Colors!



95-811



95-813



95-815

VP Racing Fuels

LIMITED On-Site VP Racing Fuel and Product Availability. Please Call.



S&W Branded 6 Bolt & 12 Bolt Fuel Caps

Fuel cell cap kits are designed as a direct replacement for any Jaz, Harwood, or RCI fuel cell with a 4.438" 6 hole or 5.343" 12 hole bolt circle. Made from 6061 aluminum and anodized for corrosion protection. Each cap is o-ring sealed and comes complete with stainless hardware.

P/N

- | | |
|----------------------------|-----------------------------|
| 95-322 6 Bolt Black Cap | 95-327 12 Bolt Black Cap |
| 95-323 6 Bolt Blue Cap | 95-329 12 Bolt Blue Cap |
| 95-324 6 Bolt Red Cap | 95-328 12 Bolt Red Cap |
| 95-325 6 Bolt Silver Cap | 95-330 12 Bolt Silver Cap |
| 95-326 6 Bolt Polished Cap | 95-331 12 Bolt Polished Cap |



Lightweight, non vented Pro-werks Fill Caps feature deep finger notches for a positive and comfortable grip. The 6061-T6 American melt billet aluminum is CNC machined for accuracy, and is available in your choice of either brilliance anodized black, red, blue, or silver, as well as micro-polished aluminum finish. The design uses a radial squeeze action on a Buna O-ring for a secure seal. Precision machined quick-start coarse threads make using our caps a breeze. Pro-werks' mounting bungs are crafted from steel, aluminum or stainless and available in both weld-in and bolt-on styles. Easy Turn Fill Caps are available many sizes and mounting

CALL for Pricing & Availability



Fuel Cap Reinforcing Rings

Works with S&W branded caps and PRO-WERKS caps. 1/4" thick aluminum 2-piece Ring with 1/4"-20 tapped holes.



80-002



80-001

P/N

- 80-002 6 Hole Reinforcing Ring
- 80-001 12 Hole Reinforcing Ring



Throttle Cable Mounts

S&W's new throttle cable mount kits are available for 4150 style Holley or Race Demon carbs and for 4500 style Holley or King Demon carbs.

Kits are available for use with or without an inline air throttle controller and each kit includes a cable hook clip to mount a 33C style Morse type cable. Clip mounting hardware is also included. Optional GM cable clips are available for those wishing to retain their factory style cable.

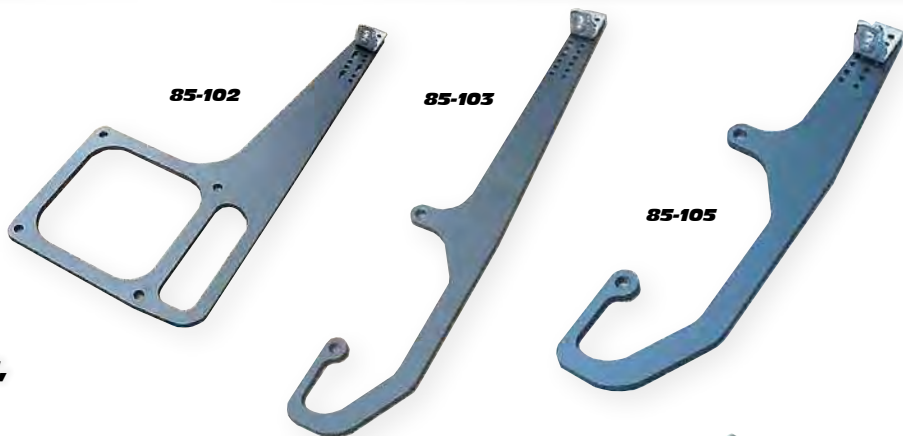

Throttle Return Spring Kit, 2300/4100 Series Holley Carb Mount

The answer to your throttle return spring linkage problems if you're running a 2300/2305 series two-barrel or 4150/4160 series four-barrel Holley carburetor. Designed and built rugged enough for competition, yet it's polished chrome finish is suitable for the finest show car. Includes one set of heavy and one set of light springs



P/N

85-64927 Throttle return spring kit

Throttle Return Spring Kit, 4500 Dominator & King Demon Carb

Fits a 4500 series and King Demon carburetors. Made from sturdy 12-gauge steel and finished in (electrostatic paint) E-coat satin black Kit includes heavy and light sets of stainless steel return springs, all mounting hardware and complete installation instructions

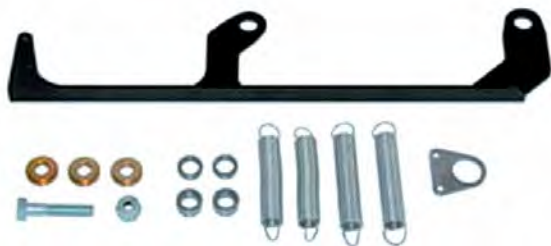

P/N

85-64918 Throttle return spring kit

Adjustable Throttle Linkage Kit

Adjustable 2 piece throttle linkage features quick release carb pivot. All necessary hardware included



P/N

15-042 3/16-24 linkage kit
15-043 1/4-28 linkage kit

Lean Out Kit

A must for warming up your alcohol motor on cold mornings, S&W's lean out kit comes with all necessary hose & fittings. Steel & aluminum slide valve offers much better service & seal than steel or brass ball valves.

P/N

94-500 Lean out valve & hose kit



P/N

85-101 Throttle return bracket & spring
85-102 Throttle cable mount 4500 carb w/ air controller
85-103 Throttle cable mount 4150 carb w/ air controller
85-104 Throttle cable mount 4500 carb
85-105 Throttle cable mount 4150 carb
70-65057 Throttle cable mounting clip - early GM square
70-65058 Throttle cable mounting clip - early GM round



Scoop Tray Mounts

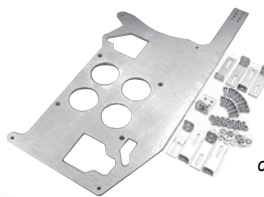

S&W offers a trick scoop mounting kit. Kits are available to fit dragsters and altered with 4150 or 4500 series Holley carbs. Includes easy-to-remove hold down clamps which allow quick access for carb tuning & maintenance.

Easy to install, the mounting plate, fits under the carb, features 4 vertical support brackets. The support brackets can be adjusted for height and fastened to the scoop base tray

P/N

95-636 Scoop mount, 4150 series Holley
95-636L Scoop mount, 4150 series Holley LONG
95-637 Scoop mount, 4500 series Holley
95-637L Scoop mount, 4500 series Holley LONG
95-638 Scoop mount, Flying Toilet
95-641 Scoop mount, Ron's Terminator (1051 & 1055)
95-643 Scoop mount, Ron's Terminator (1060)



BRACKETS & TABS

TRACK LOCATOR / PANHARD BAR / LADDER BAR 4-LINK & REAR HOUSING MOUNTING

Fabricating mounting brackets can be the most time consuming task for any race car builder. S & W offers the same high-quality brackets used on cars built in S & W's own shop to save you time during your race car construction. Add that extra touch of professionalism to your race car with S & W Race Cars brackets and tabs.

Track Locator & Panhard Bar



Panhard bar housing bracket

P/N
40-2181



Panhard bar housing bracket gusset

P/N
40-2182



Bolt on track locator bar bracket
• 3/16" mild steel
• 5/8" mounting hole
• 1/2" or 5/8" bolt holes

P/N
■ 60-481 (1/2" bolt hole)
■ 60-484 (5/8" bolt hole)



Bolt on track locator bar bracket
• 3/16" mild steel
• 3/4" mounting hole
• 1/2" bolt holes

P/N
■ 60-482

■ 60-485 (Pro 500 Wishbone U-Bracket)
(1/2" hole with 1-3/16" between legs)

4-Link



Laser-link frame bracket
• 3/16" thick
• 5/8" holes
P/N
40-118-1 (Mild Steel)
40-117-1 (Chrome Moly)



Laser-link housing bracket
• integral shock mount center bracket
• 3/16" thick
• 5/8" holes
• fits 3" axle tube
P/N
06-013 (Mild Steel)
06-013moly (Chrome Moly)



Laser-link housing bracket
• laser cut
• 3/16"
• 5/8" holes
• fits 3" axle tube
P/N
40-118-2 (Mild Steel)
40-117-2 (Chrome Moly)

Laser-link housing bracket
• laser cut
• 3/16"
• 5/8" holes
• fits 2-3/4" axle tube
P/N
40-126 (Mild Steel)

S-10 Laser-link housing bracket for use on housings used with 10-509 frame kit
• laser cut
• 3/16" mild steel
• 5/8" holes
• fits 3" axle tube
P/N
45-462-01



Frame bracket
• water jet cut
• 3/16" thick
• 1/2" or 5/8" holes
• for use with S&W frame rail 10-410-01
• notched for 1-5/8" crossmember
P/N
40-135-1 (Mild Steel)
40-135CM-1 (Chrome Moly)
10-410-4L(5/8" holes)



Frame bracket
• water jet cut
• 3/16" thick
• 1/2" holes
• included in 40-135 4-link package
P/N
40-135-5 (Mild Steel)
40-135CM-5 (Chrome Moly)



Housing bracket
• integral wheelie bar mount
• water jet cut
• 3/16" thick
• 1/2" holes
• fits 3" axle tube
P/N
40-135-2 (Mild Steel)
40-135CM-2 (Chrome Moly)



Housing bracket
• integral shock mount
• water jet cut
• 3/16" thick
• 1/2" holes
• fits 3" axle tube
P/N
40-135-3 (Mild Steel)
40-135CM-3 (Chrome Moly)



Housing bracket
• water jet cut
• 3/16" thick
• 1/2" holes
• fits 3" axle tube
P/N
40-135-4 (Mild Steel)
40-135CM-4 (Chrome Moly)

Street Rod

Frame Bracket for Street Rod Bar
• water jet cut
• 3/16" thick mild steel
• fits 2x3 tubing
• crossmember notch centered between link holes
P/N
40-125-01



Rear Housing Bracket for Street Rod Bar
• water jet cut
• 1/4" thick mild steel
• fits 3" axle tube
P/N
40-125-02
P/N
40-125-02-325 fits 3.25" axle tube

Offset Frame Bracket for Street Rod Bar
• water jet cut
• 3/16" thick mild steel
• fits fits 2x3 tubing
• crossmember notch offset to end of bracket
P/N
40-125-06

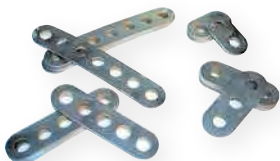

Doubler Kit - welds to frame & chassis brackets of 40-135 4-link kit
• water jet cut
• 1/8" mild steel or moly
• 1/2" holes

P/N
40-135-DBL (Mild Steel)
40-135CM-DBL (Chrome Moly)



Mr.Horn

Dragster 4-Link



- Laser-link housing bracket
- integral shock mount
 - water cut
 - 3/16" Domex
 - 5/8" holes
 - available for big web or small web Ford housings

P/N

- 05-004BW-L1 Big web housing - left side - outer
- 05-004BW-L2 Big web housing - left side - inner
- 05-004BW-R3 Big web housing - right side - outer
- 05-004BW-R4 Big web housing - right side - inner
- 05-004SW-L1 Small web housing - left side - outer
- 05-004SW-L2 Small web housing - left side - inner
- 05-004SW-R Small web housing - right side - inner & outer
- 05-004i Strange Dragster Housing Bracket (Inner)
- 05-004O Strange Dragster Housing Bracket (Outer)
- 05-047 Lower Shock Mount Bracket
- 05-023i Upper Shock Mount Tab Inner
- 05-023o Upper Shock Mount Tab Outer



05-047 05-023i 05-023o

Dragster Solid Rear Mount



- Dragster housing brackets
- water jet cut
 - 1/4" Domex
 - 7/16" holes

- P/N
- 05-091 (3" Axle Tube)
 - 05-092 (3-1/4" Axle Tube)



- Dragster rear end mount chassis plate
- 3/16" Domex
 - 7/16" holes
 - 2 required

- P/N
- 05-093

Funny Car - Rear Mount

- Funny car rear end mount chassis plate
- 1/8" chrome moly
 - 7/16" holes
 - 12" long
 - includes 2 FC-078 reinforcing plates

- P/N
- FC-006



Master Cylinder & Brake Part Brackets



- P/N
- 60-326 Chevy/Mopar Type Master Cylinder Mount
 - 1-50
 - 51-up

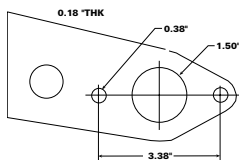

- 5 mounting positions
- 5" Pedal adjustment
- 10" x 2-3/4"
- 1/8" Mild steel
- Welds to frame and mounts pedal #15-354 shown below left

- P/N
- 60-328 Wilwood Brake Pedal Mount
 - Sorry No Quantity Discounts Available

- Wilwood/Strange/Tilton master cylinder mounting bracket
- 1/8" mild steel
 - 3/8" mounting holes
 - 3" bolt centers

- P/N
- 60-325



- Brake Tee Mount
- designed for 9" Ford
 - 3/8" mounting hole
 - works w/ #3 bulkhead tee

- P/N
- 60-103



- Inner Wheel Bracket P/N 40-312 -02
- Outer Wheel Bracket P/N 40-312-01
- Inner & Outer Wheel Bracket Kit P/N 40-312 KIT

Ladder Bar



- Ladder bar crossmember bracket
- 1/4" mild steel
 - 5/8" holes
 - fits 2" x 3" crossmember
- P/N
- 40-209-1



- Ladder bar crossmember bracket
- 1/4" mild steel
 - 5/8" holes
 - Available for 1-5/8" or 1-3/4" crossmember
- P/N
- 40-2102 (1-3/4")
 - 40-2103 (1-5/8")



- Ladder bar housing bracket
- 1/4" mild steel
 - 5/8" holes
 - 7-1/16" hole centers
- P/N
- 40-206 (3" Axle Tube)
 - 40-226 (2-3/4" Axle Tube)
 - 40-206-350 (3-1/2" Axle Tube)

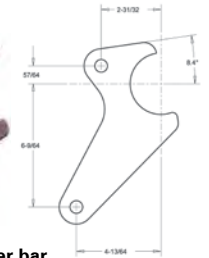

- Ladder bar front bracket used on 10-300, 10-301 & 10-302 frames
- P/N
- 10-300-1

Wheelie Bar Mount



- Wheelie bar housing bracket fits S&W wheelie bar with leaf type lower spring
- P/N
- 40-314



- Wheelie bar housing bracket fits S&W wheelie bar with leaf type lower spring & 2x3 housing brace
- P/N
- 40-329



- Wheelie bar housing bracket fits S&W wheelie bar with tubular lower bar & 2" x 3" housing brace
- P/N
- 40-3127
 - 40-3452 (PRO 500)



- Wheelie bar housing bracket fits S&W wheelie bar with tubular lower bar
- P/N
- 40-3121

- Tubular Wheelie Bar Crossmember Bracket
- P/N 40-3124

Funny Car

Funny car body mount hook

- waterjet cut
- 3/8" aluminum
- 1/4" holes

P/N
FC-016

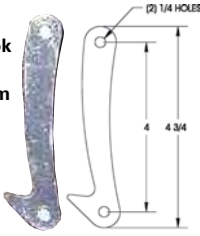

Funny car coil mount

- welds to chassis
- .090" chrome moly

P/N
FC-002



Funny car left side fire bottle linkage

- waterjet cut
- 1/4" aluminum

P/N
FC-013



Funny car right side fire bottle linkage

- waterjet cut
- 1/4" aluminum

P/N
FC-014

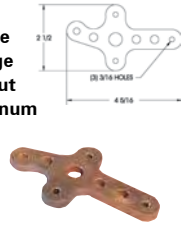

Funny car roof hatch hinge

- waterjet cut
- 1/8" aluminum
- 3/16" holes

for funny car bodies with NO vertical lip or flange around hatch opening

P/N
FC-017

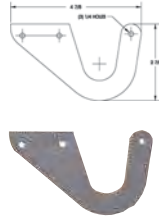

Funny car roof hatch handle

- waterjet cut
- 1/8" aluminum

for funny car bodies with NO vertical lip or flange around hatch opening

P/N
FC-018

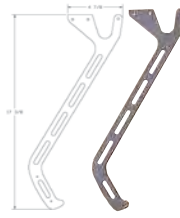

Funny car roof hatch hinge

- waterjet cut
- 1/8" aluminum
- 3/16" holes

P/N
FC-017-2005



Funny car roof hatch handle

- waterjet cut
- 1/8" aluminum

for funny car bodies with vertical lip or flange around hatch opening

P/N
FC-018-2005



Shock Mounts

Extra long Adjustable shock mount housing bracket

- 7-1/2" long
- 1/4" mild steel
- 3/8" holes
- fits 3" axle tube

P/N
40-2241 without back brace
40-2291 with 2x3 back brace



40-2241
(shown)



40-2291
(shown)



40-2221
(shown)



40-2211
(shown)

Standard Adjustable shock mount housing bracket

- 5-1/2" long
- 1/4" mild steel
- 3/8" holes
- fits 3" axle tube

P/N
40-2221 without back brace
40-2211 with 2x3 back brace

Bolt on replacement shock mount brackets for 40-222 & 40-224 adjustable shock mounts.
Also used in all Pro/Series 2000 shock & spring kits

P/N
40-2223 Left Side
40-2222 Right Side



Upper Shock Bracket as used on 10-300 & 10-400 series frames.

P/N
60-358

Door Car Body Mounts



Body Mount Pad

P/N
95-501



Front End Mount Guide Plate

- Sold in each
- slotted for 7/8" tube
- 1/8" mild steel
- welds to top of round tube frame rail

P/N
60-380



Front End Mount Guide Plate

- Sold in each
- slotted for 7/8" tube
- 1/8" mild steel
- welds to side of 2x3 frame rail

P/N
60-370

BRACKETS & TABS - DRAGSTER / ALTERED / FUEL PUMP & MISC.

Dragster / Altered

Dragster front motor mount saddles
 • Sold in pairs
 • 3/8" holes
 • fits 1-1/4" frame rail



P/N
 05-076..as pictured
 05-078.. with no tabs
 05-079 no tabs to fit 1-3/8" CM rails

Quarter Pro and Phantom shifter mount for S&W dragster



P/N
 60-359

B&M Bandit or Frameworks shifter mount for S&W dragster or altered - long



P/N
 60-354

B&M Bandit or Frameworks shifter mount for S&W dragster or altered - short



P/N
 60-356

Dragster shifter cable mount bracket
 • use with cable hook # 70-505
 • 1/8" mild steel



P/N
 05-046

Chrome moly chassis slot reinforcement plates



P/N
 • 05-140 - 1/4" x 1" slot
 • 05-141 - 1/4" x 1-1/4" slot
 • 05-142 - 5/16" x 2" slot
 • 05-143 - 7/16" x 2" slot

Engine Limiter Brackets
 • sold each



P/N
 20-608-1

Crotch Strap Anchor
 • weld on
 • sold each
 • 3/16" mild steel



P/N
 60-349

Coil Mount Large or Small Block Chevy
 • Bolts to cylinder head
 • fits MSD coils
 • 1/4" aluminum
 • includes mounting hardware



P/N
 60-361..BBC
 60-366..SBC

BG Fuel Regulator Mount
 • bolts to big block Chevy head
 • fits 2 port & 4 port regulators
 • 1/4" aluminum
 • tapped 1/4-20

P/N
 05-125



Charging plug mount
 • waterjet cut
 • 16 ga. mild steel
 • 5/8" holes
 • fits 3" axle tube



P/N
 05-033

Steering box shaft support
 • for SPE box with 3/4" dia. shaft
 • 1/8" moly



P/N
 60-367

Trans limiter chassis tab
 • 3/8" hole
 • 1/8" steel



P/N
 60-319

Dragster Switch Mount
 • welds to frame
 • mounts starter button & 4 toggle switches
 • 9-1/2" x 1-3/16" x 1/2"
 • for switches see page 54

P/N
 05-005



Miscellaneous



Door or Chute Release handle
 • Aluminum
 • 6-1/4" L (9" L. Avail. Ask)

P/N
 95-5521 1/8" thick (shown)
 95-5521A 1/4" thick

P/N
 FC-118-04 Chute Handle Air Actuated.
 3/16"th. 6-61 Alum, Appx. 8-1/2" long w/3/16 Mntg. Hole, (4) 1/4" Pin Holes

Tie Down Anchor
 • weld on
 • 3/16" mild steel
 • sold each

P/N
 60-381



Transmission Bracket
 • weld on
 • fits 1-3/8" tube



P/N
 60-355

SPE & Stiletto rack & pinion mount
 • weld on
 • 4130
 • sold each

P/N
 60-316



Fuel Pump Mounting Bracket

This trick, lightweight mounting bracket is the same part used on S&W's award winning dragsters & altered. Bracket welds in an upright position to any chassis crossmember and accepts all Barry Grant fuel pumps as well as Holley "blue" pump. Can be easily modified to fit other brand pumps.

P/N
 05-031 Fuel pump mount bracket

05-031 (shown)



TABS - FIREWALL / SEAT BELT / CHUTE / ROD END & MORE



P/N
 60-300
 Firewall Tab



P/N
 60-303 Large
 Firewall Tab

P/N
 60-303RW
 1/8" chrome moly
 reinforcing washer



P/N
 60-304
 Steering Wheel Tab



P/N
 60-305 Light
 Parachute Tab

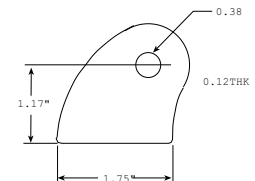
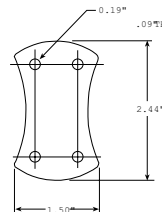
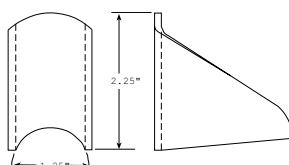
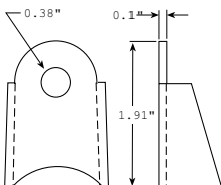

TABS - FIREWALL / SEAT BELT / CHUTE / ROD END & MORE



P/N
60-308
Seat Belt Tab

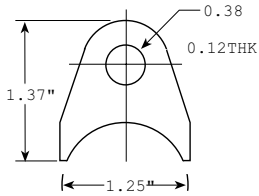

P/N
60-315 Seat Belt Tab with 1/4" hole
.120" thick
Sorry No Quantity Discounts Available



P/N
60-310
P & S Dragster Rack & Pinion Mounting Tab

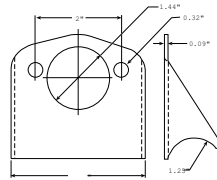

P/N
60-311
Rod End Clevis 3/4" Tube
• Fits 3/8" Rod End

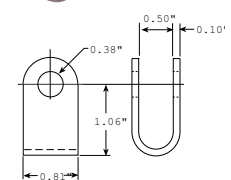

P/N
60-312
Rod End Clevis 7/8" Tube
• Fits 3/8" Rod End

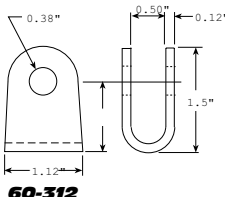

P/N
60-313
Radius Rod Frame Bracket
• Fits 3/8" Rod End

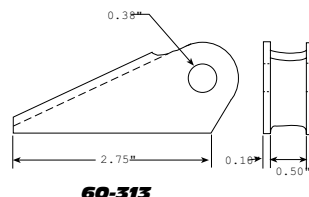

P/N
60-314
Universal Tab

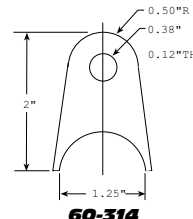

P/N
60-321
• Headlight mount tabs
A-arm mount - each

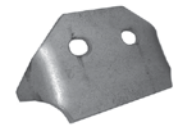

P/N
60-322
• Headlight mount tabs - chassis mount - each



P/N
60-309 Wing Strut Mounting Tab
2-1/4" long, 1" tall,
3/16" thick, 5/16" hole



P/N
60-336
Bell Crank Tab

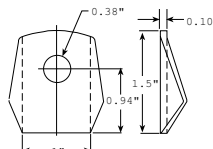

P/N
60-302
Universal Tab 1-1/2" H.
3/8" Dia. Hole
• FLAT BOTTOM



60-302

P/N
60-353
Universal Tab 2.75" high
1/2" Dia. Hole
• FLAT BOTTOM

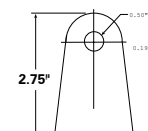

60-353

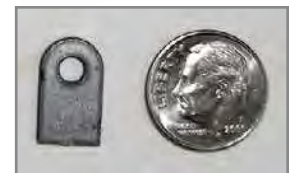

P/N
60-337
Window Mount Tab
(used in kit P/N 95-654)

P/N
60-352
Universal Tab
• Fits 1-5/8" Tube

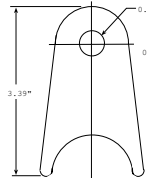

P/N
40-2385
Universal Tab 2.75" high
5/8" Dia. Hole
• FLAT BOTTOM

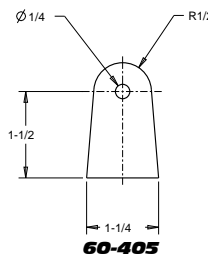

60-405



40-2385

P/N
60-352CM
Chrome Moly Universal Tab
• Fits 1-5/8" Tube

P/N
60-401
Butler Head Support Mounting Tab
(fits P/N ADV-22131 Kit)



WHEEL SPACERS

Custom billet aluminum wheel spacers, made "in house" on S&W's waterjet easily, solve minor tire to frame clearance problems. All spacers are available to fit 1/2" or 11/16" wheel studs. Sold in pairs

- 90-001 1/4" thick, 11/16" stud, 4-1/2" & 4-3/4" bolt circle
- 90-002 1/2" thick, 11/16" stud, 4-1/2" & 4-3/4" bolt circle
- 90-003 5/8" thick, 11/16" stud, 4-1/2" & 4-3/4" bolt circle
- 90-004 1/4" thick, 11/16" stud, 5" & 5-1/2" bolt circle
- 90-005 1/2" thick, 11/16" stud, 5" & 5-1/2" bolt circle
- 90-006 5/8" thick, 11/16" stud, 5" & 5-1/2" bolt circle
- 90-007 1/4" thick, 1/2" stud, 4-1/2" & 4-3/4" bolt circle
- 90-008 1/2" thick, 1/2" stud, 4-1/2" & 4-3/4" bolt circle
- 90-009 5/8" thick, 1/2" stud, 4-1/2" & 4-3/4" bolt circle

- 90-010 1/4" thick, 1/2" stud, 5" & 5-1/2" bolt circle
- 90-011 1/2" thick, 1/2" stud, 5" & 5-1/2" bolt circle
- 90-012 5/8" thick, 1/2" stud, 5" & 5-1/2" bolt circle
- 90-014 1/4" thick, 1/2" stud, 4 lug with 4-1/4" bolt circle
- 90-015 1/2" thick, 1/2" stud, 4 lug with 4-1/4" bolt circle
- 90-016 1/4" thick, 1/2" stud, 8 lug with 6-1/2" bolt circle
- 90-017 3/8" thick, 1/2" stud, 8 lug with 6-1/2" bolt circle
- 90-018 1/2" thick, 1/2" stud, 8 lug with 6-1/2" bolt circle
- 90-023 5/8" thick, 1/2" stud, 8 lug with 6-1/2" bolt circle



Aluminum Hose Ends

For use with rubber lined braided hose

P/N	
94-1001	#4, straight
94-1002	#6, straight
94-1003	#8, straight
94-1004BL	#10, straight
94-1005	#12, straight
94-1006	#16, straight
94-1009	#6, 45 deg.
94-1010	#8, 45 deg.
94-1011	#10, 45 deg.
94-1013	#16, 45 deg.
94-1015	#4, 90 deg.
94-1016	#6, 90 deg.
94-1017	#8, 90 deg.
94-1018BL	#10, 90 deg.
94-1020	#16, 90 deg.

Steel Hose Ends

For use with Teflon lined braided hose

94-4005S	Steel #3, straight
94-2014	Steel #4, straight
94-2015	Steel #3, 45 deg.
94-2016	Steel #4, 45 deg.
94-2017	Steel #3, 90 deg.
94-2018	Steel #4, 90 deg.
94-2040	Steel #6, straight
94-2042	Steel #6, 90 deg.

Braided Steel Hose

94-3204	Rubber lined hose, #4
94-3209	Rubber lined hose, #6
94-3214	Rubber lined hose, #8
94-3219	Rubber lined hose, #10
94-3224	Rubber lined hose, #12
94-200-16	Rubber lined hose, #16
94-3253	Teflon lined hose, #3
94-600-04	Teflon lined hose, #4
94-3262	Teflon lined hose, #6
94-600-08	Teflon lined hose, #8

Assembled Brake Hoses

94-5502	#3, 12", 90 deg. to straight
94-5503	#3, 15", 90 deg. to straight
94-5504	#3, 18", 90 deg. to straight
94-5505	#3, 21", 90 deg. to straight
94-5506	#3, 24", 90 deg. to straight
94-5508	#3, 30", 90 deg. to straight
94-5602	#3, 12", straight to straight
94-5603	#3, 15", straight to straight
94-5606	#3, 24", straight to straight
94-5608	#3, 30", straight to straight

Steel Brake Adapters

94-FM10324-04	#4 flare - 3/8-24 inv female
94-FM10324-31	#3 flare - 3/8-24 female
94-FM10324-41	#4 flare - 3/8-24 female
94-FM10716-03	#3 flare - 7/16-24 inv. female
94-4129	#3 flare - 3/8-24 inv. female

Tube Nuts and Sleeves

94-6055	#3 Alum tube nut
94-6056	#4 Alum tube nut
94-6057	#6 Alum tube nut
94-6058	#8 Alum tube nut
94-6063	#3 Alum tube sleeve
94-6064	#4 Alum tube sleeve
94-6065	#6 Alum tube sleeve
94-6066	#8 Alum tube sleeve

Female Swivel Couplers

94-4000	Alum, #6
94-4001	Alum, #8
94-4002	Alum, #10

TECH
TIP

Don't Forget to Upgrade Your Brake Plumbing!

Don't compromise the efficiency of your new brake system with OEM style rubber brake hoses. Now is the time to replace them with high quality hose & fittings. Not only will they last longer under extreme service but they will provide a better "feel" at the pedal.

See page 59 for brake system plumbing suggestions

Flare Unions

P/N	
94-6033S	Male #3, steel
94-6033	Male #3, alum
94-6034S	Male #4, steel
94-6034	Male #4, alum
94-6035S	Male #6, steel
94-6035	Male #6, alum
94-6036	Male #8, alum
94-6037	Male #10, alum
94-6038	Male #12, alum

Flare to Pipe Adapters

94-4243	Steel #4 to 1/8"
94-4244	Steel #3 to 1/8"
94-6042	Alum #4 to 1/8"
94-6045	Alum #6 to 1/8"
94-6046	Alum #6 to 3/8"
94-6052	Alum #6 to 1/2" (B&M cooler)
94-6044	Alum #6 to 1/4"
94-6047	Alum #8 to 1/4"
94-6049	Alum #8 to 1/2"
94-6048	Alum #8 to 3/8"
94-6050	Alum #10 to 1/2"
94-6051	Alum #12 to 1/2"
94-4279	Steel #3 to 1/8" 90 deg
94-6079	Alum #3 to 1/8" 90 deg
94-6080	Alum #4 to 1/8" 90 deg
94-6084	Alum #6 to 3/8" 90 deg
94-6087	Alum #6 to 1/4" 90 deg
94-6085	Alum #8 to 1/4" 90 deg
94-6086	Alum #8 to 3/8" 90 deg
94-2015	Steel #3 to 1/8" 45 deg
94-6095	Alum #6 to 1/4" 45 deg
94-6096	Alum #8 to 3/8" 45 deg

Flare Tees

94-4298	Male #3, steel
94-6099	Male #3, alum
94-AN824-06D	Male #6, alum
94-6103	Male #8, alum

Flare to Pipe Tees

94-2700	Alum #3 to 1/8" run tee
94-6106	Alum #3 to 1/8"

Bulkhead Fittings

94-2809	Steel run tee, #3
94-2770	Steel #3, straight
94-6117	Alum. #4, straight
94-6118	Alum. #6, straight
94-6119	Alum. #8, straight
94-6120	Alum. #10, straight
94-6121	Alum. #12, straight
94-6123S	Steel #3, 90 deg
94-6123	Alum. #3, 90 deg
94-6124	Alum. #4, 90 deg
94-6125	Alum. #6, 90 deg
94-6126	Alum. #8, 90 deg
94-4330	Steel tee, #3
94-6131	Alum. tee, #4
94-4387	Steel bulkhead nut, #3
94-6188	Alum. bulkhead nut, #4
94-4025	Alum. bulkhead nut, #6
94-6190	Alum. bulkhead nut, #8
94-6192	Alum. bulkhead nut, #12

Flare, O-Ring and Allen Head Pipe Plugs

P/N	
94-AN806-03D	Flare plug, #3
94-AN806-04D	Flare plug, #4
94-AN806-06D	Flare plug, #6
94-AN806-10D	Flare plug, #10
94-AN814-06D	O-ring plug, #6
94-AN814-08D	O-ring plug, #8
94-AN814-10D	O-ring plug, #10
94-AN932-01D	Allen head 1/16" npt
94-AN932-02D	Allen head 1/8" npt
94-6082	Allen head 1/8" npt
94-AN932-03D	Allen head 1/4" npt
94-AN932-04D	Allen head 3/8" npt
94-AN932-05D	Allen head 1/2" npt

Flare Caps

94-AN929-03D	Flare cap, #3
94-6195	Flare cap, #4
94-6196	Flare cap, #6
94-6197	Flare cap, #8
94-6198	Flare cap, #10
94-AN929-12D	Flare cap, #12

Gauge Adapters

94-GA-03	Straight #3 to 1/8"
94-GA-04	Straight #4 to 1/8"
94-GA-903	90 deg. #3 to 1/8"
94-GA-904	90 deg. #4 to 1/8"

Carb & Fuel Pump Fittings

94-4022	Holley #6 - 7/8-20
94-4021	Holley #8 - 7/8-20, long
94-CW901-10	Washer for - 7/8-20 fittings
94-FB206	Alum #6 to 1/2-20 inv

Fuel Pressure Fittings

94-FP190	#6 union with 1/8" tap
94-FP191	#8 union with 1/8" tap
94-FP192	#6 male to #6 female with 1/8" tap
94-FP193	#8 male to #8 female with 1/8" tap
94-FP195	#8 flare to 1/4" with 1/8" tap

Steel Tube Nuts & Sleeves

94-3591	Steel #3 tube nut
94-6056	Steel #4 tube nut
94-3667-1	Steel #3 tube sleeve
94-819-04P	Steel #4 tube sleeve

Bleeders

55-391	Bleeders (4 pack)
--------	-------------------

Steel Hard Line

55-805	25" roll 3/16" hard line
55-806	25" roll 1/4" hard line

Master Cylinder Fittings

94-2356	#3AN to 1/2-20 inverted
94-2357	#3AN to 9/16-20 inverted





WATERJET
CUTTING

CNC MILLING
AND TURNING

CNC TUBE &
SHEET BENDING

3D PRINTING

ENGINEERING
& DESIGN



engineering@
swracecars.com



610-948-7303
ext. 133

f S&W Precision Specialties

@SWFAB



DID YOU KNOW
We don't just build race cars?

**CALL US
FOR A
QUOTE!**

Since 1959, S&W has been designing and manufacturing quality race cars and components. S&W Precision Specialties, under the S&W Performance Group, specializes in one-off, short run and large run fabrication; utilizing the latest in waterjet cutting, CNC machining and bending, tube processing and welding technology.

We now also offer 3D printing capabilities and stock a variety of different colors and materials.

Visit our website for a full list of capabilities and see what S&W Precision Specialties has to offer!



PRO/SERIES CHASSIS KITS & BLUEPRINTS

Now available to the serious, do-it-yourself chassis builder, is a complete line of drag chassis kits. Each chassis kit incorporates the championship quality and engineering excellence found in every S&W race car built "in house". Every S&W race chassis combines the knowledge gained through over forty years of on-track testing & race experience with the latest in CAD technology to assure the builder the highest-quality chassis kit available. Each kit is specifically designed for your specific application and each "doorslammer" chassis is designed for your particular body style. This assures you a chassis that not only fits properly but is easier to build too! Each Pro/Series Chassis Kit comes complete with detailed assembly blueprints to guide you during assembly. When you purchase an S&W Pro/Series Chassis Kit you also get benefits of the full technical support available only through a racing company! Please call for more info.

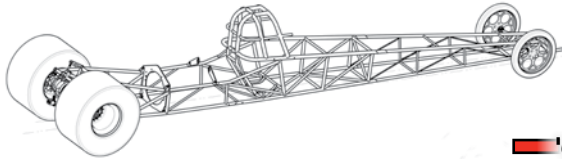

Pro/Series Dragster with Solid Mounted Rear

All chrome-moly cut, bent & notched • A-arm components • A-arm mounting brackets • 9" Ford housing w/ Olds ends • Rear housing mounts • Water jet cut Chevy mid motor plate and Chevy front motor plate blanks • Motor plate mounting brackets • Dragster blue print

● **225" with standard 9" Ford housing**

P/N **05-001-AET** 21" shoulder hoop, advanced ET

P/N **05-001W-AET** 23" shoulder hoop, advanced ET

● **225" with Strange aluminum 9" housing**

P/N **05-001S-AET** 21" shoulder hoop, advanced ET

P/N **05-001W-S-AET** 23" shoulder hoop, advanced ET

● **245" with NO rear housing**

P/N **05-003-AET** 21" shoulder hoop, advanced ET

P/N **05-003W-AET** 23" shoulder hoop, advanced ET

● **245" with Strange aluminum 9" housing**

P/N **05-003S-AET** 21" shoulder hoop, advanced ET

P/N **05-003W-S-AET** 23" shoulder hoop, advanced ET

● **245" with S&W chromemoly fabricated 9" housing**

P/N **05-003F-AET** 21" shoulder hoop, advanced ET

P/N **05-003WF-AET** 23" shoulder hoop, advanced ET

Pro/Series Dragster with Swing Arm Rear Suspension

• All chrome-moly cut, bent & notched • A-arm components • A-arm mounting brackets • Strange alum. rear housing • Rear housing mounts • Water jet cut Chevy mid plate • Water jet cut Chevy front motor plate blanks • Motor plate mounting brackets • Welded swing arm, upper tubes and 8 chrome moly rod ends • Anti roll bar, housing & links • Adj. lower shock mounts • 4-Link dragster blue print

● **230" with Strange aluminum 9" housing**

P/N **05-002-AET** 21" shoulder hoop

P/N **05-002W-AET** 23" shoulder hoop

● **245" or 255" with Strange aluminum 9" housing**

P/N **05-090W-AET** 23" shoulder hoop, advanced ET

125" Pro/Series Altered 4-Link with Fabricated 9" housing

• All chrome-moly tubing, cut & bent • Jig welded front axle • Motor plate blank • Motor plate mounting brackets • 4-link front mounts • Altered blue print

P/N **06-001**

125" Pro/Series Altered Solid Mounted Rear

• All chrome-moly tubing, cut & bent • Jig welded front axle • Motor plate blank • Motor plate mounting brackets • Rear housing t mounts • New 9" housing cut for width • Olds housing ends • Altered blue print

P/N **06-125**

150" Advanced ET Altered Swing Arm with Strange aluminum housing

• All chrome-moly cut & bent • Jig welded front axle • Strange alum. rear housing • Rear housing mounts • Water jet cut Chevy mid plate • Water jet cut Chevy front motor plate blanks • Motor plate mounting brackets • Jig welded swing arm with 8 chrome moly rod ends • Anti roll bar, housing & links • Adj. upper shock mounts • Altered blue print

P/N **06-150** for use with S&W Bantam body - sold on page 84

BluePrints are Included FREE with Chassis Kits!



All S&W Chassis Kits are \$ ITEMS

Assembly blue prints complete with tubing cut lists are available for the experienced do-it-yourselfer.

Note:

Assembling a drag race vehicle from a blue print is not for a beginner and should only be attempted by a skilled and experienced fabricator.



'67 Camaro Roadster with Swing Arm Rear Suspension

• All chrome-moly cut, bent & notched • Strange alum. rear housing • Rear housing mounts • Welded swing arm, upper tubes and 8 chrome moly rod ends • Anti roll bar, housing & links • Adj. lower shock mounts • Water jet cut Chevy mid plate • Water jet cut BB Chevy front motor plate • Motor plate mounting brackets • Bolt in transmission crossmember • Upper & lower strut mounts • blue print

P/N **07-005**

200" Nostalgia Frnt. Eng. Dragster

• All chrome-moly tubing, cut & bent • Jig welded front axle • 6 Point cage • 1/4" Aluminum mid motor plate blank • Aluminum front motor plate blanks • Ford 9" rear housing with Olds ends • Rear housing mount plates • Anti rotation device • Front engine dragster blue print

P/N **05-004**

225" Top Fuel Nostalgia F.E. Dragster

6.0 E.T. and Over

P/N **05-059**

225" Top Fuel Nostalgia F.E. Dragster

5.99 E.T. and Under

P/N **05-096**

P/N **05-096FR** w/Fab Rear Housing

Top Alcohol Funny Car

All chrome-moly cut, bent & notched • Hemi motor plate • Motor plate mounting brackets • Rear housing mounts • Funny Car blue print

P/N **06-002**

Full Body Cars • All tubing cut & bent • Full body car blue print

~ All Full Body Chassis Kits meet SFI spec 25.4 - (7.50-8.49 - 3600# Max) ~

~ Chrome Moly Full Body Kits are for 6.0 sec. ET & Slower @2,800lbs. ~

~ Mild Steel Full Body Kits are for 7.50 sec. ET & Slower @2,800lbs. ~

~ Other specs available. Please call 1-800-523-3353~

08-500
09-500
08-501
09-501
08-504
09-504
08-505
09-505
08-507
09-507

67-69 Camaro - mild steel
67-69 Camaro - chrome moly
70-81 Camaro - mild steel
70-81 Camaro - chrome moly
55-57 Chevy - mild steel
55-57 Chevy - chrome moly
62-67 Chevy II - mild steel
62-67 Chevy II - chrome moly
63 Corvette - mild steel
63 Corvette - chrome moly

08-510
09-510
08-511
09-511
08-513
09-513
08-530
09-530
08-561
09-561
08-562
09-562
08-568
09-568
08-570
09-570
08-579
09-579
08-580
09-580

68-74 Nova - mild steel
68-74 Nova - chrome moly
Vega - mild steel
Vega - chrome moly
82-92 Camaro - mild steel
82-92 Camaro - chrome moly
93-99 Camaro - mild steel
93-99 Camaro - chrome moly
64-68 Mustang - mild steel
64-68 Mustang - chrome moly
69-73 Mustang - mild steel
69-73 Mustang - chrome moly
89-96 Thunderbird - mild steel
89-96 Thunderbird - chrome moly
62-65 Fairlane - mild steel
62-65 Fairlane - chrome moly
94-04 Mustang - mild steel
94-04 Mustang - chrome moly
94-2002 S-10 extended cab pick up - mild steel
94-2002 S-10 extended cab pick up - chrome moly

08-1503
09-1503
08-1516
09-1516
08-1520
09-1520
08-1532
09-1532
08-1537
09-1537
08-1591
09-1591
08-2532
09-2532
08-2537
09-2537
08-3566
09-3566
08-3574
09-3574
09-1550

68-72 Chevelle - mild steel
68-72 Chevelle - chrome moly
78-88 G.M. G-Body - mild steel
78-88 G.M. G-Body - chrome moly
65-69 Impala 2 door - mild steel
65-69 Impala 2 door - chrome moly
94-97 Cutlass - mild steel
94-97 Cutlass - chrome moly
Opel GT - mild steel
Opel GT - chrome moly
70-76 Duster/Demon - mild steel
70-76 Duster/Demon - chrome moly
68-70 Charger - mild steel
68-70 Charger - chrome moly
1978-1993 Mustang - mild steel - fastback or notchback
1978-1993 Mustang - chrome moly - fastback or notchback
2005 & Newer Mustang - mild steel
2005 & Newer Mustang - chrome moly
2017 C7 Corvette - chrome moly

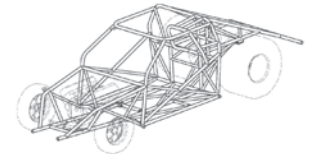

DRAGSTER & ALTERED WINGS // MOUNTING KITS

All S&W wings feature a .040 aluminum skin with die-formed internal members to provide strength and ensure an aerodynamic contour that will hold its shape run after run. 1/4" 6061-T6 aluminum mounting brackets are mounted to the internal members for maximum strength. The S&W wing mounting kit provides a strong, rigid mounting fixture for any wing. This allows for adjustment to the angle of attack. Each kit is constructed of chrome moly tubing and includes streamline main supports, preformed mounting tabs, clevis and tube ends, spherical rod ends and Grade 8 bolts with lock nuts.

- P/N**
- 05-026 36" Super Comp Wing
 - 05-027 48" Dragster Wing
 - 05-028 Econo Dragster Wing Mounting Kit (36" above top frame rail)
 - 05-029 Econo Dragster Wing Mounting Kit (48" above top frame rail)
 - 06-026 30" Altered wing
 - 06-030 Altered roll cage wing mounting
 - 06-028 Altered streamline wing mount kit (mounts to roll cage - 18" above)
 - 06-030 Altered aluminum wing mount kit (mounts to roll cage - 6" above)



Super Comp Spill Plate



Nostalgia Spill Plate



Top Fuel Spill Plate

S&W Altered Roll Cage Wing Mount

'NHRA' Approved Design

P/N 06-030



05-028
Shown with 05-126 wing & Sold Unassembled

06-126 ~&~ 06-028
Shown together & Sold Unassembled Roll Cage Not Incl.



06-030

FRONT CANARD WINGS & MOUNTING KIT

Used for years on S&W's dragsters and altered, these popular canard wings are now available for the do-it-yourselfer. Kit includes two (2) 12" canard wings, spill plates and hardware. Wings will need final trimming to fit your car's nose. Mounting kit sold separately.

- P/N**
- 05-025 Canard Wing Package
 - 05-225M Canard Wing Mounting Kit



DRAGSTER SIDE FLARE KIT

ALUMINUM FLARES Button to Dragster Engine Bay side panels ahead of headers, INCLUDES: Left & Right side panels, mounting tubes, tabs, dzus buttons, springs, mounting tube frame is welded.

- P/N**
- 05-645 Dragster Side Flare Kit



CARBON WING & MONO-STRUT UPRIGHT

The new favorite of the Top Dragster crowd, S&W's new carbon fiber wing and mono strut stand. The carbon skin will withstand those 200+ mph charges! Mount sold separately.

Call for pricing & availability.
1-800-523-3353



DRAGSTER & ALTERED 6 POINT CAGE KITS - SHOULDER HOOPS

S & W offers the same 6 point roll cages & shoulder hoops used on our dragsters and altered in kit form to the home chassis builder. Cage kits are made from 1-5/8" x .083" wall chrome moly tubing and include a helmet tube kit. Shoulder hoops are 1-1/2" x .065" wall chrome moly tubing.

- P/N**
- 05-062 Dragster - standard 6 point roll cage kit
 - 05-062W Dragster - standard 6 point roll cage kit
 - 05-063 Dragster - shoulder hoop (2 pc. 1-1/2" x .065 - up to 24" inside) requires 05-063S for Advanced ET
 - 05-063S Dragster - shoulder hoop sleeves for advanced ET.
 - 05-069-21 Dragster - shoulder hoop (1 pc. 1-1/2" x .058 - 21" inside at bends)
 - 05-069-23 Dragster - shoulder hoop (1 pc. 1-1/2" x .058 - 23" inside at bends)
 - 06-006 Altered - 6 point roll cage kit
 - 06-007 Altered - shoulder hoop (1 pc - 1-1/2" x .065 - 20" inside)
 - 06-066 Funny Car - 6 point roll cage kit
 - 06-067 Funny Car - shoulder hoop (5 pcs - 1-1/2" x .065 - 20" inside)
 - 05-066 Helmet tube kit
 - 04-066 Junior Dragster Helmet tube kit
 - 13-624 6 Point roll cage to customer specs (call for info)

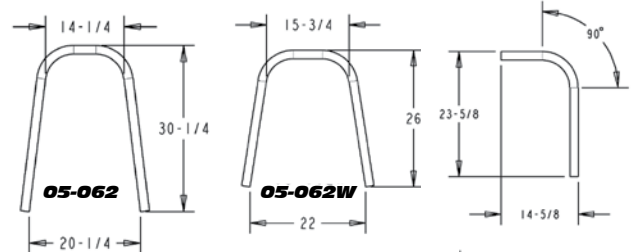

TIG Welding Wire

- 05-ER70S2-1 .045 tig wire - 1#
- 05-ER70S2-5 .045 tig wire - 5#
- 05-ER70S2-10 .045 tig wire - 10#

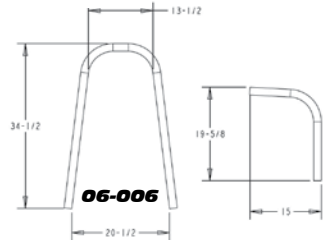

S&W Race Cars Dragster & Altered roll cages kit are available only in 4130 chrome moly tubing. These roll cages requires Heliarc (TIG) welding for proper installation. Installation of these roll cages also requires some cutting & fitting skills and should be attempted only by an experienced fabricator and welder.

DRAGSTER SWING ARM CONVERSION

With the growing trend toward swing arm dragsters, S&W Race Cars has developed a conversion package which will allow you to update your conventional, solid rear dragster to a swing arm, coil over shock equipped model. This package includes :

- Fixture welded rear section with all necessary brackets & tabs
- Welded swing arm & upper link package with moly brackets
- Eight (8) chrome moly spherical rod ends
- Torsion bar, housing & links
- Strange Engineering, aluminum 4-link housing
- Parachute mount
- All necessary tubing
- Moly housing brackets & adj. lower shock mounts

- P/N**
- 05-019 Dragster swing conversion package
 - 05-250 Complete drive shaft...(Std. Shortys)
 - 05-056 Welded swing arm

will replace bottom 4-link tubes & wishbone on any S&W 4-link dragster with Strange aluminum housing



30-250



social @SWRACECARS

website SWRACECARS.COM

DRAGSTER BODY PARTS & COMPONENTS

Dragster Windshields

Pro-Glass dragster windshields are used on most dragster from E.T. Brackets to Top Fuel Dragsters.

P/N	95-652T
95-652	Clear dragster windshield - 27" long x 17" wide x 7" high
95-652T	Tinted dragster windshield - 27" long x 17" wide x 7" high
95-653	Clear Tall dragster windshield - 27" long x 17" wide x 9" high
95-653T	Tinted Tall dragster windshield - 27" long x 17" wide x 9" high
95-673	Clear dragster windshield - 33" long x 20" wide x 9" high
95-673T	Tinted dragster windshield - 33" long x 20" wide x 9" high



Flip Up Dragster Tow Hook Kit

Now, the same popular flip up tow hook kit used on S&W built dragsters is available to the do-it-yourself, home chassis builder. This 5/16" aluminum, precision cut tow hook includes mounting brackets & grade 8 hardware.

P/N
05-011
Dragster flip up tow hook kit



Dragster Nose Hangers

Protect your dragster nose while towing to & from the track with this handy S&W dragster nose hanger. Mounts to your trailer wall a keeps the nose out of harms way during trailering. Made of .040" aluminum and includes dzus spings & pop rivots. Fits any of the noses sold above, and for NEW Push-Button Nose too!



05-138

05-103

P/N
05-138 Dragster Nose Hanger
05-103 Dragster Nose Hanger for SW Push Button Nose

Dragster Nose

Now available three different versions of our lightweight, high-strength, dragster nose. These noses are the same ones used on all S & W super class dragsters. Made specifically for S & W by Performance Fiberglass all three measure 31" long and 8-1/2" wide at the front. Nose number 95-659 is 10-1/2" wide at the rear of the nose, while numbers 95-660 & 95-661 are 11". All measurements are taken on the inside of the nose. Available in fiberglass only, nose require trimming to fit your application.

P/N
95-659 Fiberglass dragster nose full rounded
95-660 Fiberglass dragster nose semi rounded
95-660C Carbon dragster nose semi rounded
95-661 Fiberglass dragster nose sloped



95-659 95-660 95-661

Stripe Taker / Beam Breaker

To be used with P/N 95-660 Nose. .060"th. Aluminum, Includes Mounting Hardware

P/N
05-660 Stripe Taker

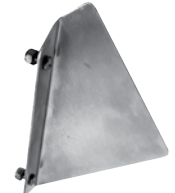

Aluminum Dragster Body Kits

Crating & Shipping NOT INCLUDED in Pricing. Call for C&S Estimate.

The S&W aluminum body kits are available for our 21" and 23" Pro /Series dragster kits. Kits include performed cowls and side panels with "aero" lips on the bottom edge. Also included are all necessary quarter-turn buttons and springs as well as the necessary windshield mounting hardware. Due to several nose & windshield choices, this kit does not include the nose or windshield.

P/N	95-639	Body kit for 21" 225" - 230" S&W dragster
	95-639W	Body kit for 23" 225" - 230" S&W dragster
	95-665	Body kit for 21" 245" S&W dragster
	95-665W	Body kit for 23" 245" S&W dragster

Ask Us About our Slip-Off Push-Button Dragster Nose!



Fiberglass & Carbon Fiber Dragster Bodies

- One Piece Fiberglass or Carbon Fiber Construction.
- Recessed front simplifies mounting of nose
- Accepts any of the noses shown on this page
- Easily trimmed for windshield
- 21" or 23" wide versions designed to fit S&W hardtail or 4-link

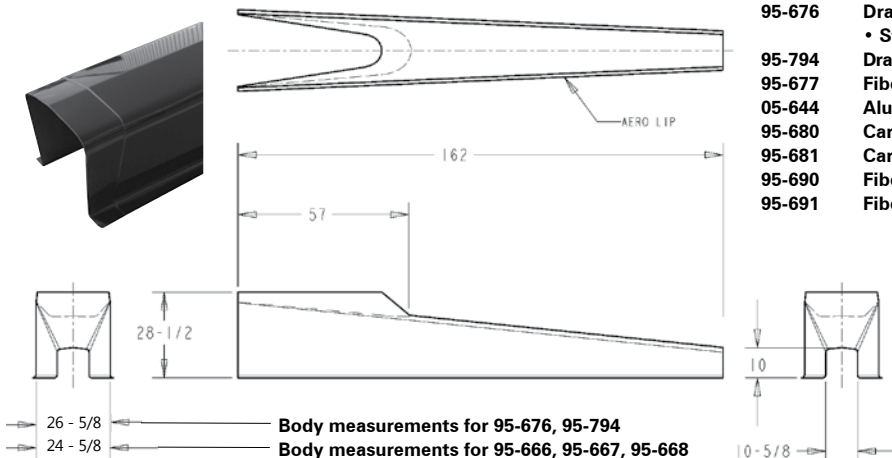

Crating & Shipping NOT INCLUDED in Dragster Body Pricing. Call for C&S Estimate.

P/N

95-666	Dragster body for 21" shoulder hoop • Fiberglass • Standard Weight
95-667	Dragster body for 21" shoulder hoop • Fiberglass • Lightweight Weight
95-668	Dragster body for 21" shoulder hoop • Carbon Fiber
95-676	Dragster body for 23" shoulder hoop • Fiberglass • Standard Weight
95-794	Dragster body for 23" shoulder hoop • Carbon Fiber
95-677	Fiberglass dragster body mounting kit
05-644	Aluminum side panels (back of body to rear tire) - pair
95-680	Carbon side panels (46" x 25") - pair
95-681	Carbon side panels (64" x 26") - pair
95-690	Fiberglass side panels (46" x 25") - pair
95-691	Fiberglass side panels (64" x 26") - pair

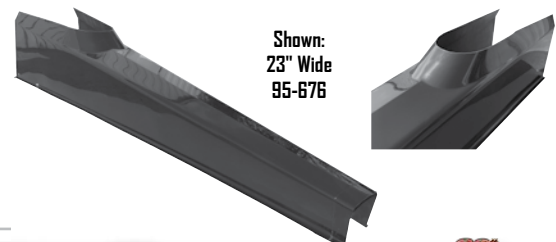

■ Scoop Tray Mount

S&W offers a trick scoop mounting kit. Kits are available to fit dragsters and altereds with 4150 or 4500 series Holley carbs. Includes easy-to-remove hold down clamps which allow quick access for carb tuning & maintenance. Easy to install, the mounting plate, fits under the carb, features 4 vertical support brackets. The support brackets can be adjusted for height and fastened to the scoop base tray



- P/N**
- 95-636 Scoop mount, 4150 series Holley
 - 95-636L Scoop mount, 4150 series Holley LONG
 - 95-637 Scoop mount, 4500 series Holley
 - 95-637L Scoop mount, 4500 series Holley LONG
 - 95-638 Scoop mount, Flying Toilet
 - 95-641 Scoop mount, Ron's Terminator (1051 & 1055)
 - 95-643 Scoop mount, Ron's Terminator (1060)

■ Scoop Tray

Used on conjunction with the mounting kits sold above, these custom formed aluminum scoop mounting trays are available flat or in a 4-1/4" high version and make a secure mount for the scoop on your dragster or altered. Available for all the scoops shown at the right, these trays attach to the scoop with four (4) quarter turn, quarter turn fasteners, making removal quick and easy. Scoop trays can be custom ordered for any scoop not listed below. Please call for more info.



- P/N**
- 05-201 4150 carb, flat, for scoops with 14" x 22" base
 - 05-202 4500 carb, flat, for scoops with 14" x 22" base
 - 05-203 4150 carb, flat, for scoop with 14" x 22" base
 - 05-204 4500 carb, flat, for scoop with 14" x 22" base
 - 05-205 5-1/8" Flying Toilet, flat, for scoops with 14" x 22" base
 - 05-206 5-1/8" Flying Toilet, flat, for scoop with 14" x 22" base
 - 05-211 4150 carb, 4-1/4", for scoops with 14" x 22" base
 - 05-211AF 4150 carb, 4-1/4", with built in filter mount (filter not included) for scoops with 14" x 22" base
 - 05-212 4500 carb, 4-1/4", for scoops with 14" x 22" base
 - 05-212AF 4500 carb, 4-1/4", with built in filter mount (filter not included) - for scoops with 14" x 22" base
 - 05-213 4150 carb, 4-1/4", for scoops with 11-3/8" x 18-5/8" base
 - 05-214 4500 carb, 4-1/4", for scoops with 11-3/8" x 18-5/8" base
 - 05-215 5-1/8" Flying Toilet, 4-1/4", for scoops with 14" x 22" base
 - 05-215AF 5-1/8" Flying Toilet, 4-1/4", with built in filter mount (filter not included) - for scoops with 14" x 22" base
 - 05-216 5-1/8" Flying Toilet, 4-1/4", for scoop with 11-3/8" x 18-5/8" base
 - 05-217 7-3/8" Ron's Terminator, 4-1/4", for scoops with 14" x 22" base
 - 05-217AF 7-3/8" Ron's Terminator, 4-1/4", with built in filter mount (filter not included) - for scoops with 14" x 22" base

■ Scoop Tray Insert

For 4-1/4" tall scoop tray and 4500 series carbs. Smooths air flow into carb. Does not fit with air filter.

- P/N**
- 95-682 Scoop Tray insert
 - 95-682C Carbon Fiber Scoop Tray insert



■ Scoop Filter

End the worries of stones and dirt going down your carb or injector with S&W's new scoop filter. The aluminum filter housing attaches to your scoop tray and the air cleaner eliminates the worry of dirt in your engine. Fits all popular Dragster scoops. Housing measures 16" x 10-1/4" x 4"

- P/N**
- 95-624 Scoop filter kit
 - 95-624-02 Replacement filter

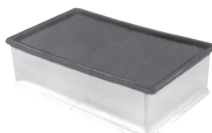

■ Mini Headlight Kits

"Mini" & "ULTRA SMALL" headlights are perfect for mounting on dragster a-arms or in the nose. Please call.

- P/N**
- 85-257 Black Mini headlights - pair - 2 lbs. 3" Long x 2-1/4" High x 3-5/8" Deep
 - 60-321 Headlight mount tabs - A-Arm mount - ea.
 - 60-322 Headlight mount tabs - Chassis mount - ea.
 - 85-270 Black ULTRA SMALL headlight with base - ea. 3.5oz. 2" front to back, 1.33" diameter



■ Air Scoops

S&W offers a wide selection of Air Scoops. Due to the constantly changing air scoop styles and theories, it is impossible to list all of the available air scoops. Listed below are some of the more popular scoops. If you don't see the scoop you want, call us and we will be glad to special order it for you.

- P/N**
- 95-622 Aero Comp III Scoop
 - 95-647 Aero Flow Scoop
 - 95-647C Aero Flow Scoop (carbon fiber)
 - 95-671 2005 Scoop
 - 95-671C 2005 Scoop (carbon fiber)
 - 95-672 2006 Scoop
 - 95-674 2007 Scoop
 - 95-674C 2007 Scoop (carbon fiber)
 - 95-683 Double Barrel Scoop
 - 95-689 2011 Scoop
 - 95-694 2013 3-Hole Scoop
 - 95-694C 2013 3-Hole Scoop (carbon fiber)



95-689



95-694



95-683



95-622



95-647

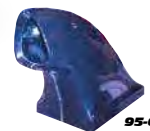

95-671



95-672

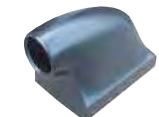

95-674

Scoop
Plugs
Available!

■ Dial-In Board Mount

Available angled for S&W scoop trays or flat for vertical deflector plate mounting. Black anodized. Dial board not included



We are a full line Digital Delay dealer. Call us with your needs 1-800-523-3353

- P/N**
- 85-770 Scoop tray mount
 - 85-771 Deflector plate mount
 - 85-769 3 digit flip dial board
 - 85-768 4 digit flip dial board w/suction cups
 - 85-932 Megadial 4 Dgt. w/blue letters, cable & controller



■ Access Door Kits

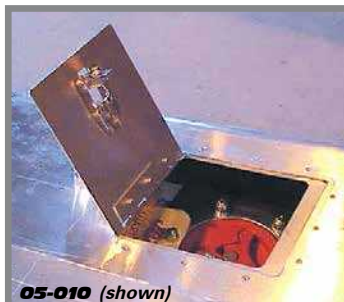

05-010 (shown)

S&W Race Cars offers three sizes of access door kits that can be easily installed in aluminum or fiberglass body panels. Custom formed aluminum lower frame insures a no-flex mounting base for the lightweight aluminum hinge and precision cut aluminum door. All hardware included. Fuel door size is 5-1/4" x 5", Universal access door size is 6-1/4" x 10-1/2" Computer/Weather Station door size is 8-1/8" x 12-7/8"

- P/N**
- 05-010 Fuel door kit
 - 05-013 Computer/Weather Station door kit
 - 05-053 Universal access door kit

Carbon Fiber Dragster Seats

These custom made dragster seats are used in each of S&W Race Cars award winning Pro Series Dragsters. Seats are designed to fit shoulder hoops that are 21" or 23" wide inside and are 20" tall. Each seat features Kevlar/Carbon reinforcing in the seat belt slot locations and other pass thrus.

- P/N
 95-663 Carbon fiber dragster seat - 21"
 95-664 Carbon fiber dragster seat - 23"
 95-663G Fiberglass dragster seat - 21"



Adjustable Throttle Pedal

S&W's adjustable throttle pedals make it easy to adjust your car to a different size driver. Simply unbolt the unit and move the cable mount, pedal stop and pedal as one unit.

****Weld-In Model Avail. for OEM Door Car Floors****

- P/N
 05-120 Dragster Adjustable throttle pedal
 15-049 Door Car Adj. throttle pedal (Welds to OEM Floor)



Dragster Dash Panel & Cover

S&W's in house water jet has made it possible for us to offer dragster dashboards in almost any configuration. Because of the almost limitless possibilities please call us with your specific needs. **Now Avail. Stepped, Concave, Special Bends...Please Ask!**



Carbon Fiber Dash Cover

P/N
 05-072CF

Dragster Adjustable Pedal Mounts

S&W Race Cars adjustable pedal mounts make it easy to install the adjustable S&W throttle pedal (sold above) or a Wilwood brake pedal & master cylinder mount part #15-354 in any rear engine dragster.

- P/N
 05-118 Adj brake pedal mount
 05-119 Adj throttle pedal mount



Seat Belt Hook Set

These handy hooks eliminate searching for your belts once you slide down into the seat. Simply hang the harness ends on the hooks and no more searching for the belts! Set includes four precision waterjet cut hooks which must be welded in place on your chassis.

- P/N
 05-121 Seat belt hook set

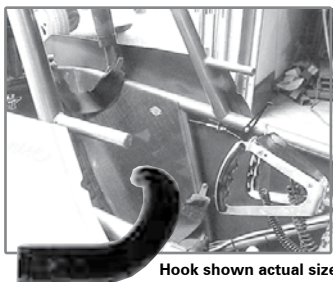

Dragster Shifter Mounts

S&W Race Cars shifter mounts make it easy to install almost any type shifter in your rear engine dragster.

- P/N
 05-071 Quarter Stick mount
 mounts between driver's legs
 60-359 Quarter Pro & Phantom mount
 mounts on right side



Rear Engine Dragster Steering Column Kit

Works with all S&W rear engine dragster kits. Spindles, rack and tie rods sold separately See Pg's. 36 & 37

- P/N
 35-373 Steering Column Kit

Dragster Front A-Arm Kit

Kits include all necessary tubing and spindle bosses.

- P/N
 35-003 Front a-arm kit for SPE, P&S and RCP spindles
 35-003L Front a-arm kit for Stiletto & Strange spindles

Dragster "Glove" Boxes

Three different, all aluminum "glove boxes" are designed to fit easily across the floor in front of the seat or almost anywhere else you may want to mount it. Our standard version, measures 3-1/2" x 16-1/4" x 2-1/4" and our new, larger "CSI" version, measuring 4" x 16-1/4" x 2-1/2" is designed to hold the popular CSI tire gauge. Our biggest "glove" box measures 6" x 12" and 3" deep. This box is designed to fit in front of the seat and run from front to back between the drivers legs. All three styles are available for dragsters with fuel line tunnels in the cockpit or with a smooth bottom for dragsters without cockpit tunnels.

- P/N
 05-041 Dragster glove box for cockpit tunnel
 05-041CSI Dragster glove box for cockpit tunnel
 05-042 Dragster glove box for flat floor
 05-042CSI Dragster glove box for flat floor
 05-054 Dragster glove box for 3" cockpit tunnel
 05-054W Dragster glove box for 5" cockpit tunnel
 95-054 Dragster glove box for flat floor

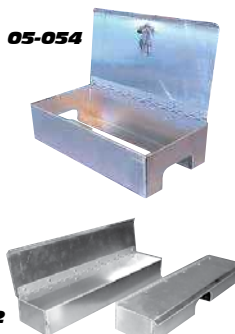

Dragster Floor & Foot Box Bulkhead Kit

The S&W floor & foot box bulkhead kit includes precision formed aluminum panels and fuel line tunnel. Also included are all necessary quarter turn buttons and springs for mounting.

- P/N
 95-640 Floor & bulkhead kit for 21" chassis

Custom Upholstery

S&W offers custom seat and roll bar padding for use in S&W built dragsters, funny cars, altered & street roadsters.



- P/N
 95-002 F/C Nomex seat cover (fits S&W funny cars only!!)
 95-003 Dragster seat pad - black cloth
 95-004 Dragster seat pad - black vinyl
 95-005 Roll Bar pads - Taylor, fitted, SFI strip type
 95-012 Roll Bar pads - JAZ, 3' length SFI strip type fits 1-5/8" roll cage tubes
 95-015 Roll Bar pads - JAZ, 3' length SFI strip type fits 1" helmet tubes
 95-008 Altered seat pad - black cloth
 95-009 Altered seat pad - black vinyl
 95-010 Aero Roadster seat pad - black cloth
 95-011 Dragster seat pad - black cloth (sit-up style car)
 95-013 Full dragster seat pad with pocket (fits seat #95-663)
 95-014 Back saver - inflatable lumbar support
 95-016 Full dragster seat pad with pocket (fits seat #95-664)

Transmission Limiters

S & W transmission limiters are designed for "hard-tail" rear engine dragsters utilizing a "shorty" powerglide, 9" Ford center section and a Mark Williams, standard length, quick disconnect coupler or for most 4-link dragsters. This kit is designed to eliminate lateral movement of the engine & transmission during hard acceleration. S&W Race Cars highly recommends that this kit be used in conjunction with a set of engine limiters, part# 20-608 sold on this page.



Large 1-1/4" tubular handle for comfortable grip
05-149C

- P/N**
- 05-022** Trans limiter kit - S&W "hardtail" dragster
 - 05-023** Trans limiter kit - S&W "4-link" dragster
 - 05-123** Trans limiter kit - Universal "hardtail" dragster
 - 05-129** Trans limiter kit - Universal "4-link" dragster
 - 05-149** Trans handle only with limiter mounts
 - 05-150** Trans limiter kit w/handle - S&W "hardtail" dragster
 - 05-151** Trans limiter kit w/handle - S&W "4-link" dragster
 - 05-152** Trans limiter kit w/handle - Univ. "hardtail" dragster
 - 05-153** Trans limiter kit w/handle - Universal "4-link" dragster

Trans Handles with Built-In Recovery Tank Handle

S & W transmission handles with integral fluid recovery tank, can be purchased with or without transmission limiters. Kit includes all necessary fittings & hose. Kits are available in chrome or clear zinc plated



05-164



- P/N**
- 05-164** Trans handle w/Overflow tank Cooler mount & limiter mts
 - 05-165** Trans tank handle only with limiter mounts
 - 05-165HK** Hose kit for all tanks
 - 05-166** Trans limiters w/tank handle - S&W "hardtail" dragster
 - 05-167** Trans limiters w/tank handle - S&W "4-link" dragster
 - 05-168** Trans limiters w/tank handle - Univ. "hardtail" dragster
 - 05-169** Trans limiters w/tank handle - Universal "4-link" dragster



95-3402



95-3405



95-1150

Dragster Radiators & Mounts

Working in conjunction with a leading racing radiator company, S&W has designed an all aluminum radiator (part # 95-3402 & 95-3402AN12) to work with almost any dragster, altered or street roadster application. This radiator's overall size measures 18" wide by 19-1/2" tall and 2" thick. Also available is a radiator measuring 21" tall, 17-5/16" wide and 2-1/8" thick with two female pipe bungs which will allow a variety of hose options. This radiator comes complete with fan & shroud and can be mounted vertically or horizontally. A third option is part # 95-1150 which measures 16" tall, 14" wide and 2" thick. This radiator has (2) 3/4" NPT bungs and (1)- 1/4 NPT bung on one side and (4) 1/4"-20 mounting bosses on the other. This radiator is designed to lie down over the trans and should be used with S&W mounting kit # 05-114

- P/N**
- 95-1150** Aluminum Radiator w/fan & shroud (for use with 05-114 mounting kit)
 - 95-1151** Aluminum Radiator only (as sold with 95-1150)
 - 95-052** Replacement Fan
 - 05-114** Mount kit for 95-1150 radiator & 94-006 trans cooler
 - 95-3402** Aluminum Radiator - Dragster, Altered or S/R - Chevy
 - 95-3402AN8** Aluminum Radiator - Dragster with #8 AN outlets
 - 95-3402AN12** Aluminum Radiator - Dragster with #12 AN outlets
 - 95-3402AN16** Aluminum Radiator - Dragster with #16 AN outlets
 - 95-3402S** Shroud for Dragster radiator
 - 95-3403** Mount kit for 95-3402 for cars with angled frame rail
 - 95-3404** Pro/Stock Radiator - Dual right side
 - 95-3408** Mount kit for 95-3402 for cars with horizontal frame rail
 - 95-3405** Aluminum Radiator with shroud & fan

Dragster Cockpit Tunnel

Here's a handy little item that solves another problem every dragster owner faces. With your fuel cell or battery mounted out in front of your feet, how can you protect the fuel lines or wires that have to go through the cockpit? With an S&W Race Cars, cockpit tunnel! Available in aluminum or carbon fiber, these custom formed tunnels can be easily attached to any existing dragster floor.

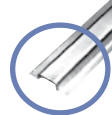
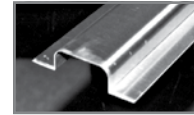

- P/N**
- 05-008** Aluminum cockpit tunnel (3" x 1-3/8" tall)
 - 05-008W** Aluminum cockpit tunnel (4-1/2" x 1-3/8" tall)
 - 05-009** Carbon cockpit tunnel (3" x 1-3/8" tall)
 - 05-081** Carbon cockpit tunnel (4-1/2" x 1-3/8" tall)

Cockpit Light 95-4277

S&W now offers 12 volt cockpit light. The light measures 1-3/4" long x 3/4" wide. Light features 3 led bulbs for plenty of illumination.



85-011

- P/N**
- 95-4277** Cockpit light
 - 85-011** Cockpit light bracket

Engine Limiters

- P/N**
- 20-608** Universal dragster engine limiter (dual)
(Bracket 20-608-1..See Pg.71)



20-608-1

20-608

Transmission Removal Handle - Front & Rear

Don't worry about dropping your pricey aftermarket aluminum aftermarket trans case with this handy transmission removal handle. 1-3/16" diameter handle - 4" long. Mounts to the center hole on all aftermarket powerglide cases. requires 1/2"-13 UNC threads.
- Rear Handle has a Mill finish. 1/4" Aluminum, Tumbled & Black Anodized - bolts to back of shorty kit. NOTE: WILL NOT WORK ON TRANS w/STOCK TYPE TAIL HOUSING !!!



- P/N**
- 05-159** Transmission removal handle - front
 - 05-155** Transmission removal handle - rear

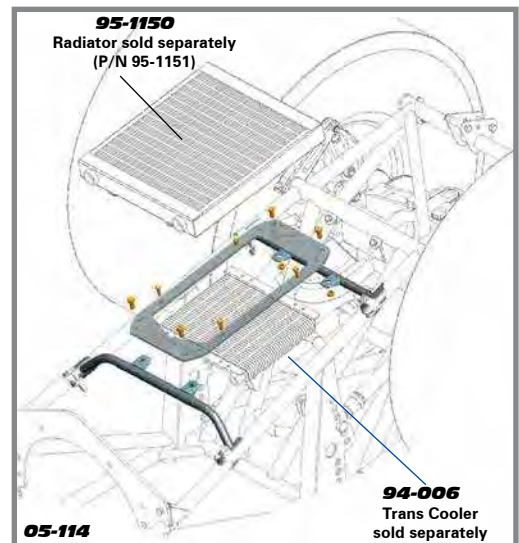

95-1150
Radiator sold separately
(P/N 95-1151)

05-114

94-006
Trans Cooler
sold separately

Remote Master Disconnect Mounting Kit - Cable Operated

This kit allows you to mount your electrical master disconnect switch in a remote location away from the back of the car. While originally designed for S&W dragsters this kit can be easily adapted to any car. Available with or without tail light mount. Cable, switch and tail light not included. Optional cockpit activation handle available



Kit includes: Master disconnect mount • Cable mounts (2)
• Rod ends (2) Handle and rear cable guide (with or without light mount)

P/N

- 85-240 Remote mount kit with tail light mount
- 85-241 Remote mount kit without tail light mount
- 85-248 Cockpit handle kit

Dragster Tail Light Kit with Bullet Mount

INCLUDES; Red LED Light, Bullet Tube End and Tubing. Fitting, Drilling and Welding required.

P/N 85-326 Dragster Tail Light



Ignition Coil Mounts

Aluminum coil mounts designed to mount popular racing coils to any small or big block Chevy cylinder head.

P/N

- 60-361 Big block - MSD Coils
- 60-362 Big block - Stock type coils
- 60-366 Small block - MSD Coils

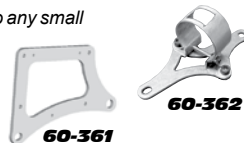

Dragster Nitrous Bottle Mount

S&W's new nitrous bottle mount kit mount (1) 25# 6-7/8" diameter bottle above the transmission. Two 1/2" aluminum bottle clamps bolt to two chrome moly crossmembers which must be welded to the saddles that clamp to the top frame rails. Kit is available for any top frame rail diameter. Please specify when ordering. Installation requires cutting, fitting and welding.

P/N

- 95-8219 Nitrous bottle mount kit



Oil Accumulator Mount

S & W's new oil accumulator mount makes installing a Moroso oil accumulator or Canton Accusump neat and easy. Kits will mount the 1.5 quart accumulator over the transmission and offers quick removal for transmission service. Mounts are available to bolt in to any S&W super class dragster or in kit form (some welding required) for other manufacturer's dragsters. No plumbing is included, but S&W stocks all the necessary hose and fittings to complete the job.



P/N

- 05-161 S&W 4-link or swing arm with 1-1/4" frame rail
- 05-162 S&W "converted" 4-link with 1-3/8" frame rail
- 05-163 Unwelded kit

Deflector Plates & Kit

S&W Race Cars deflector plates are available in many configurations. The 'formed' model follows the seat back and allows additional air flow to the radiator. 05-133 'Kit' includes all mounting hardware. Each deflector plate is made from 1/8" aluminum. *Optional:* S&W Race Cars logo distinctively milled into the plate (call for pricing)

05-133 (shown)

P/N

- 05-133 Deflector Plate Kit - Formed, w/Holes & All Mounting Hardware \$91⁹⁵
- 05-144 Deflector Plate - Flat..... \$88⁹⁵
- 05-038 Deflector Plate - Formed, w/Holes..... \$88⁹⁵
- 05-038-01 Deflector Plate - Flat, w/Holes \$88⁹⁵
- 05-038-T Deflector Plt. (TALL) Formed, w/Holes.. \$88⁹⁵



Belly Pan Kits

Tired of fighting with heavy, hard to install engine diapers on your car? Then S&W's Belly Pan kits are what you need! Made of .050" aluminum the pan measures 18-1/2" wide at front x 17-3/4" wide at rear x 28" long. Front and side walls are 4" high and Rear wall is 6" High. Walls can be easily trimmed to clear your accessories while maintaining the required 2" height. Kit includes 6 mounting tabs (Weld-On or Clamp-On) and all necessary quarter-turn fasteners for installation. Pans have a bare aluminum finish. Absorbant pads sold separately (2 pads required.)

P/N

- 05-171 Dragster Weld-On Belly Pan Kit
- 05-175 Dragster Clamp-On Belly Pan Kit
- 07-025 Door Car/Roadster Belly Pan Kit
- 05-171-03 Absorbant Pads (ea.)



CUSTOM BELLY PANS are a S&W Specialty!!

Send Us Your Drawing for a Quote.

Weight Bars

S&W Race Cars offers two styles of weight bars which can be easily adapted to any race car. Both bars are made of 2" x 3" rectangular tubing and are 18" long. The first is closed on both ends with a removable cap. This bar is designed to be filled with lead shot and offers the racer the ability to vary the weight as needed. The second is closed on one end and is designed to be permanently poured full of lead. Mounts with (2) 1/2" bolts - 13" on center. Both come complete with mounting tabs and grade 8 hardware.

P/N

- 05-020 Weight Bar (open end)
- 05-021 Weight Bar (removable cap)



Brake Line Kits

Everything to complete your brake line plumbing project. See Page 49

4-Link Dragster Driveshaft

This S&W Race Cars driveshaft is specifically designed for S&W 4-link dragsters. This driveshaft is available for standard or roller bearing "shorty" kits and 9" Fords. Includes a specially modified slip yoke, 1350 heavy duty u-joints and u-bolts. Driveshaft is shipped fully assembled.



P/N

- 30-250 Dragster driveshaft for standard shortys
- 30-251 Dragster driveshaft for roller bearing shortys

DRAGSTER PARTS & COMPONENTS

Dragster Motor Plates

S&W Motor Plates are fabricated from 6061-T6 alum. plate.

- 05-034 Mid Motor Plate for S&W Dragster Chassis
- 05-034CF Full Mid Plate w/coil mount for S&W 4-Link Chassis
- 05-034FS Full Mid Plate w/coil mount for S&W Solid Chassis
- 05-034CM Mid Plate w/coil mount for S&W Dragster
- 05-037 Mid Motor Plate Blank for S&W Dragster
- 05-049 Mid Motor Plate Blank-440Mopar/S&W Dragster
- 05-035 Front blank-2 Req.-BB or SB Chevy Dragster
- 05-043 Front blank-2 Req.-BB Chevy/S&W Dragster
- 05-043F Front (1 Pc.) BB Chevy/S&W Dragster
- 05-043F-SBC Front (1 Pc.) SB Chevy/S&W Dragster
- 05-043FW Front (1 Pc.) BB Chevy/S&W XWD Dragster
- 05-043-440 Front (1 Pc.) BB Mopar/S&W Dragster
- 05-043-460 Front (1 Pc.) BB Ford/S&W Dragster
- 05-051 Front BB Ford/S&W 4-Link Dragster

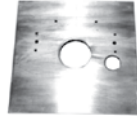

Dragster Quick Jack

- Works on most dragsters with 1-1/4" or smaller crossmember under rear housing.
- Folds for easy storage in trailer
- Lightweight, steel handle with aluminum base
- Sturdy enough for warm up use.
- Powder coated orange for high visibility
- Optional trailer mounting bracket available



- P/N**
- 05-101 Dragster quick jack - 11-3/8" tall
 - 05-101T Dragster quick jack - 12-7/8" tall
 - 05-101R Dragster quick jack - 11-3/8" tall for use with dragster featuring a 1-1/2" wide x 1" tall crossmember under rear housing
 - 05-101-H Dragster quick jack trailer mount bracket

Dragster Fuel Cell Mount Kit

Designed to mount fuel cell number 80-018 (see page 62), this kit welds directly to the lower frame rail and includes a steel mount tray, hold down strap and mounting hardware.

P/N

- 05-135 Dragster fuel cell mount kit



Ignition Panel

Specifically designed to mount between the lower frame rails just in front of the foot box bulkhead, this 19" long, 1/8" aluminum plate offers plenty of room to mount your ignition electronics and a 925 or 1200 amp Odyssey battery. Mounting tabs weld to frame rails. Battery mount kit sold separately (see below)

P/N

- 05-087 Ignition panel kit (front engine dragster)
- 05-136 Ignition panel kit (rear engine dragster)



Battery Hold Down Kit

Designed to mount a 925 or 1200 amp Odyssey battery to the above ignition plate. Aluminum hold down strap and zinc plated studs resist corrosion and provide an attractive appearance

P/N

- 05-137 Battery hold down kit



NOSTALGIA FRONT ENGINE DRAGSTER PARTS

F.E.D. Front Axle Torsion Bar Kit

P/N

- 05-173 F.E.D. Front Axle Torsion Bar Kit



17" Hayden Wire Spoked Wheels

P/N

- 90-030 Polished Alum. (SPE Only)
- 90-031 Chromed Steel (SPE & Flange)
- 90-222 Spoke Wheel Light Shield (black)

HAUDEN ENTERPRISES



Steering Kit

Includes steering wheel with black grips, rod ends & threaded tube ends, all necessary chrome moly tubing, all mounting brackets & tabs and all necessary hardware. Spindles & steering box not included - sold separately. Builder will need spindle set with two 5" arms, one additional 6" steering arm, steering box and mount.

P/N

- 35-391 Front engine dragster steering kit



Aluminum Seat Kit

Kit includes 4 pieces .050" aluminum rolled & semi fit for installation. Kit requires final trimming, fitting and finish welding. Kit also includes all necessary quarter turn fasteners, springs and spring plates.

P/N

- 05-145 Aluminum seat kit

Front Engine Dragster Wing Kit

Includes wing and all necessary hardware & brackets to mount front wing on a front engine dragster. Welding required

P/N

- 05-030 Front engine dragster wing kit.....

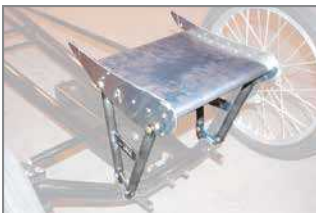

ASK About Custom Fuel Cells & Puke Tanks

F.E.D. Drive Shaft Loop with Coupler Guard

P/N 05-098...\$110⁹⁵

F.E.D. Dash/Guage Pnl.

P/N 05-070...\$104⁹⁵

F.E.D. Chute Anchor Kit

P/N 75-143

Nostalgia Top Fuel Rears



Front Torsion Bar

This torsion assembly is a reproduction as used in the '60's front motor dragsters. It features improvements to the bearings inside the arms and new provision for lubrication. The unit dimensionally is 20" center to center of the arms. The arms are 6-3/8" from the housing center to the center of the 3/8" diameter axle mount holes. The housing tube is 1-3/8" O. D. x .058 wall 4130 tubing. The torsion bar is a % hex heat-treated alloy steel with the center undercut. The arms are adjustable by means if a 7/8-48-tooth serration button that press fits to the arm. A nylon washer acts as a friction-dampening device.

P/N

- 35-016 Front torsion bar

Dropped Front Axle

Built from 1-5/8" X 0.120 4130 chrome moly tubing. King pin bosses are fixture welded to maintain correct king pin angle. King pin bores are reamed after welding. This axle is designed for use with the front torsion bar & radius rod kit sold on this page.

P/N

- 05-004FAW Front axle
- 06-146 Radius Rod Kit Torsion Bar Altered

Radius Rod Kits

Includes all necessary hardware & brackets to build a set of radius rods for a front engine dragster.

P/N 05-146 Radius Rod Kit

Canard Wing Kit

14" & 16" wide Canard Wing Kits include Right & Left side canards.

P/N 05-14WIDECANARD

Canard Kit

05-16WIDECANARD

Canard Kit



TOP ALCOHOL FC / NOSTALGIA FUNNY CAR & BANTAM BODIES

TOP ALCOHOL FUNNY CAR BODY PIECES & PARTS

Designed as a joint effort between S&W Race Cars and Roush Advanced Composites, and available only through S&W Race Cars, these body parts are specifically designed to meet the unique aerodynamic needs of Alcohol Funny Car racing. In addition, we also offer Hairy Glass' 2007 Alcohol Mustang body. Bodies and body parts are subject to a crating charge. Call for Quote.

P/N

- 05-MCTAFC-01 2010 Monte Carlo Funny Car Body - replacement roof hatch
- 05-MCTAFC-02 2010 Monte Carlo Funny Car Body - replacement hood burst panel
- FC-05-DECK 2010 Monte Carlo Funny Car Body - spoiler deck - .063 aluminum
- FC-05-SPILL 2010 Monte Carlo Funny Car Body - mag spill plates (pair)
- FC-05-MCLWK 2010 Monte Carlo Funny Car Body - Lexan Window Kit by 5 Star
- 95-9306225-2 2010 Monte Carlo Funny Car Body - Lexan Side Windows pair by 5 Star
- 95-9306335-2 2010 Monte Carlo Funny Car Body - Lexan Windshield by 5 Star
- 95-312 2010 Monte Carlo roof hatch mounting kit also fits other funny car bodies with "lip" around hatch
- 05-CHARGER-01 2007 Dodge Charger Funny Car Body - replacement roof hatch
- 05-CHARGER-02 2007 Dodge Charger Funny Car Body - replacement hood burst panel
- 05-IMPALA-01 2007 Chevrolet Impala Funny Car Body - 3/16" front windshield



C7 Corvette Roadster Bodies are available in Carbon Fiber and Fiberglass. High Quality Surface Finish Straight from the Mold.
CALL for Details



Ask Us About Tin Work & Body Mounting Services

Top Alcohol Funny Car Fabricated Rear Housings

Available as Bare Housing or Complete Assembly. We are a STRANGE & Mark Williams Dealer.

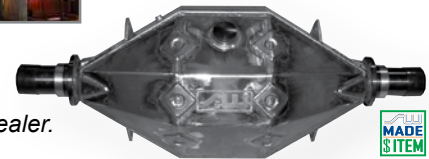

Protective 'Fire Paint' for Funny Car Bodies Sfi 54.1

TPR2 fire protection products minimize toxic smoke generation while increasing visibility in the event of car flare-up. NITRO & ALCOHOL FC's- Approximately 1.5-2.0 gal per car (by applying 2 coats) SFI Spec 54.1 Test Certification Approved Fire Extinguishing Coating. Sold in 2 Gal. Pails

P/N TPR-4028D TPR Funny Car Under Body Paint - 2 US Gallon Pail (Sfi 54.1)

****Additional Safety Products on Pg.70-72****

NOSTALGIA Funny Car & Rod Bodies



Mike Cioci

Glory Days (formerly Lawlife Kustomz) Hand-Laid Lightweight, Strong & Durable Fiberglass Nostalgia Funny Car & Rod Bodies

Funny Farm Fabrication Nostalgia Bodies Available. Call for Pricing & Availability



The Hairy Glass Carbon Fiber Nostalgia Mustang is HERE! Call for Pricing & Availability



BANTAM Bodies



View the Commercial on our YouTube Channel

All new body made to S&W specs. Features raised windscreen area, aerodynamic steering rod cover and integral chute mount. All bantam bodys are subject to a crating charge. Call for Quote.



P/N 95-669 Fiberglass Bantam Body

P/N 95-635 Fiberglass Altered Nose



This Bantam Features No Fenders & No Running Boards. All bantam bodys are subject to a crating charge. Call for Quote.

P/N 95-701 Fiberglass Bantam Body

P/N 95-670 Fiberglass Bantam Nose



Funny Car Hood Hatch Hinge & Latch Kit

This trick kit provides a hinge for any funny car front body hatch. This handy kit mounts easily and retains the hatch on the car in the event of a blower failure.

P/N
95-309 Funny Car Hood hatch hinge kit



ASK About
Custom
Fuel Cells

Funny Car Body Latch Kit

This handy kit provides a positive latch for any Funny Car body. This spring loaded release offers one-handed operation and features an aluminum handle and latch.

P/N
95-304 Funny Car body latch kit
FC-016 Spare body hook



Funny Car Dual Chute Release Kit

S&W Race Cars Funny Car dual chute release kit features a formed handle bracket, two aluminum release handles, two cable pivots, two 12' chute release cables and all necessary hardware.

P/N
95-307 Dual chute release kit



F/C Puke Tank Kit

P/N
FC-119 Funny Car Puke Tank kit



Steering Damper Kit

Fully adjustable steering damper is standard on all S&W funny cars and is easily adaptable to any funny car or altered.

P/N
35-058 Steering damper kit



Steering Kits

Includes all necessary components to build steering linkage on S&W funny cars / altered & nostalgia front engine dragsters. Does not include steering box or spindles.

P/N
35-368 Funny car steering linkage kit
35-374 Altered steering linkage kit
35-391 Nostalgia front engine dragster steering kit



Funny Car Body Mount Kit

S&W Race Cars now offers a kit for mounting your funny car body. Included in this kit is all the tubing and saddles required to fabricate the mounting "spaghetti". Also included are the preformed aluminum interior panels which require only minor trimming to your bodies contours. Also included is a precision formed, aluminum firewall frame and a pair of Lexan fire windows with aluminum frames. Finally a pair of S&W custom, aluminum body hinge plates complete the kit. Body latch kit #95-304 must be purchased separately. Also available is a roof hatch hinge & latch kit part # 95-303.

P/N
95-305 Funny Car body mount kit
FC-012 Funny Car replacement body hinge



Funny Car Escape Hatch Hinge and Latch Kit

This trick kit provides a positive latch for any roof hatch. This kit allows one-handed operation and can be operated from inside or outside the car. S&W's exclusive "hinge handle" allows the driver to open the escape hatch even with his arm restraints on and properly adjusted.

P/N
95-303 Funny Car Escape hatch hinge & latch kit

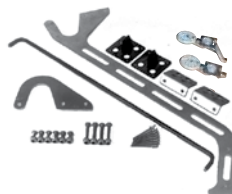

Motor Plates for Funny Cars & Altered

S&W motor plates are fabricated from 1/4", 5/16", and 3/8" 6061-T6 aluminum plate. These plates are available as blanks or precision water jet fabricated to fit your block.

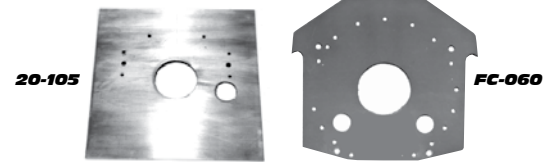

P/N
20-101 Blank 6061 2 x 2 x 1/4"
20-102 Blank 6061 2 x 2 x 3/8"
20-103 Blank 6061 2 x 2 x 5/16"
20-105 Drilled for Chevy with starter hole - 2 x 2 x 1/4"
20-105-FC Drilled for Chevy NO starter hole - 2 x 2 x 1/4"
20-106 1/4" thick Front or Mid to Customer Specification CUSTOM
20-105KB Drilled for Keith Black Hemi - 2 x 2 x 1/4"
20-108 Drilled for Chevy/starter/ 14.5" hole - 2 x 2 x 1/4"
20-112 Drilled for Chevy with starter hole - 2 x 2 x 3/8"
20-113 Drilled for 351W & 351C Ford - 2 x 2 x 1/4"
20-114 Drilled for 351W & 351C Ford - 2 x 2 x 3/8"
20-115 Drilled for 429 & 460 Ford - 2 x 2 x 1/4"
20-116 Drilled for 429 & 460 Ford - 2 x 2 x 3/8"
20-117 Drilled for 383/426/440 Mopar - 2 x 2 x 1/4"
20-118 Drilled for 383/426/440 Mopar - 2 x 2 x 3/8"
20-119 Drilled for 340 & 360 Mopar - 2 x 2 x 1/4"
20-120 Drilled for 340 & 360 Mopar - 2 x 2 x 3/8"
20-122 Drilled for Keith black Hemi - 2 x 2 x 1/4"
20-123 Mid Plate for Donovan-Mopar **S&W Cars Only**
FC-060 TA/FC 5/16" 6061-T6 aluminum
FC-074 1/4" 6061-T6 aluminum Blank Front Plates pair

Looking for Dragster Motor Plates - See Page 93

Funny Car Fire Windows

Save time and money by using these Lexan fire window with formed aluminum frames. The S&W Race Cars fire window kit assures you of two matching windows without the hassle of hand-fabricating them yourself. Kit includes two windows, two aluminum frames and all necessary hardware.

P/N
95-308 Fire window kit



Funny Car "Chimney" Kit

Required on all funny cars where the burst panel is located on the rear of the supercharger or intake manifold. Aluminum Kit meet sthe NHRA requirement and makes it easy to install the chimney or "stovepipe".

P/N
06-107 Funny Car Chimney Kit
06-106 4" Chimney Tube (Carbon Fiber)

Hatch Buttons

Button type latches are used on the roof hatches of all S&W funny cars, fuel doors and hinged access panels.

P/N
95-300 F/C hatch buttons - pair
95-301 F/C hatch button - single
95-302 Fuel or computer button - single
95-313 Pro Stock door/window button - single



Window Bezels

Aerodynamically designed, carbon fiber window bezel protects side window openings. Large size is perfect for fire extinguisher hole. Small size has a variety of uses. Sold each

P/N
FC-100 Window bezel - 6" opening
PM-100 Window bezel - 4" opening



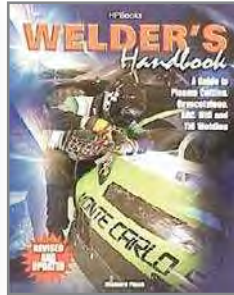
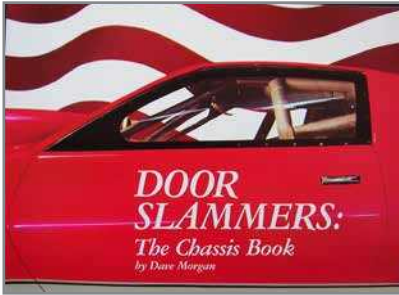

Doorslammers - The Chassis Book

Absolutely the most complete book on doorslammer chassis science ever written. Chapters include: Chassis Theory • Chassis Structure • Shocks & Springs
• Front Suspension • Rear Suspension • Brake Systems • Tires & Testing.

95-1000 DOORSLAMMERS

Welder's Handbook

by Richard Finch

Learn the basics and the secrets behind proper gas, MIG, TIG and plasma welding. Get tips on welders, fixtures and torches.

HP1513

If you are looking for a DEAL, or have some 'down-time' at the race track... Grab your racing buddies and check out S&W's Daily Sale Listings. They are E-Z to Find and located on the S&W Home Page!



DAILY FLASH SALES



VIEW ON THE HOME PAGE

S&W APPAREL & COLLECTIBLES



S&W Tee Shirts

Heavyweight, 50/50 high quality tee's, printed with the official S&W logos and designs.

P/N

99-052 Black Shop Shirt (Front & Back)
Sizes: Medium to 3XL

99-002 White Shop Shirt (Front & Back)
Sizes: Medium to 3XL



Visit the S&W Web Site to View Current Items



Illuminated Aluminum Christmas

Tree Customized with Your Name

Maximum 20 Characters for your name. Your choice of wheel mount or stand alone base. 18 Balls are included (Gold, Green & Red.) Aluminum is powder coated black. Hardware for wheel mount base is included. LED name backlighting is included. Size: 60" tall x 15.25" Wide 2" X 3" .040 Aluminum trunk. Weight: 20 LBS.

P/N

99-016 Customized Illuminated Tree



S&W Vinyl Banner

S&W Logo Banner. 30"H x 48"W / 13oz Vinyl Indoor or Outdoor use, single sided. 4 reinforced sides with 6 grommets

P/N

99-102 S&W Vinyl Banner

S&W 60th Anniversary Decal

60th Anniversary S&W Die Cut Decal with glossy lamination. Size: 4.25" x 6.50"

P/N

99-024 Collectable 60th Anniversary S&W Decal



Billet License Plate

S&W Race Cars logo beautifully reproduced as license plates for the S&W fan. Polished, billet aluminum for the ultimate appearance.

P/N

99-009 Billet Brushed Finish Aluminum License Plate



Aluminum Key Chain

S&W logo waterjet cut aluminum key chain w/tumbled smooth finish.

P/N

99-008 Aluminum Key Chain with ring



Plastic Key Chain

S&W Rapid Prototyping logo 3D Printed key chain

Colors: Black, Blue, Orange, Gray

99-XXX Aluminum Key Chain with ring



Stainless Racer Hitch Plugs

High quality hitch receiver plugs feature black powder coated plug with brushed stainless steel face. Available in three styles S&W logo - funny car - dragster.

P/N

99-110 S&W Logo
99-111 Dragster Design
99-112 Funny Car Design



3D Printed Dragster Ornaments



Dragster Ornament is made of 3D Printed plastic 6" Long x 1-1/2" Tall x 1/4" Deep, Hang hook included.

P/N

99-018ORANGE Orange Ornament
99-018BLUE Blue Ornament
99-018GRAY Gray Ornament
99-018BLACK Black Ornament



99-018RED Red Ornament

60th Anniversary 3D Printed Funny Car Ornaments

Funny Car Ornament is made of 3D Printed plastic 6" Long x 1-5/8" Tall x 1/4" Deep, Hang hook included.

P/N

99-019ORANGE Orange Ornament
99-019BLUE Blue Ornament
99-019GRAY Gray Ornament

99-019BLACK Black Ornament
99-019RED Red Ornament



1964



1973



1988



2017



Please visit our new multi device user friendly swracecars.com web site to read our complete company history. You can also take a tour of the shop, on our YouTube Channel. Subscribe for more!



It has been said that life was simpler in the 50's, but that wasn't necessarily true if you were a drag racer living on the east coast. In those early days of drag racing, Southern California was the home to all the major chassis builders, component manufacturers, and speed equipment retailers that were crucial to the growth of our sport. Walt Weney Jr. and his racing partner, Jim Amole, were two east coast racers who were tired of relying on companies 3,000 miles away and Walt decided to do something about it.

In 1959, Walt founded S&W Speed Shop in a small 15 x 20 foot basement of his dad's sheet metal shop in Spring City. There, Walt put his welding and sheet metal skills to use, first on his own car, then on his customers' race cars. Through his & Jim's experience on the track, and at his shop, Walt honed the art of race car fabrication into a precise science and a full-time occupation. During the past 60 years, the Weney Family, employees and loyal customers have contributed to S&W's American success story.

~ S&W Performance Group President: Michael Weney ~

You can trust S&W made components to withstand the abuse you put them through, because we build them to withstand the abuse we put them through!!



Randy & Kaitlyn Krause



John Burke



Tom Hoosigian



Lee & Brian Grinnell



Michael Barbalinardo



John Konnick

Car sales and service manager, Randy Krause & daughter Kaitlyn, compete in weekly E.T. wars & Big-Buck drag races with Randy's swing-arm S&W Dragster & Kaitlyn's super pro Camaro. || Engineer, John Burke, campaigns his VW in SCCA competition & drag races in his Mustang. || Sales Manager, Tom Hoosigian, is a well respected NHRA Division One super comp competitor. || Sales rep. Lee Grinnell & waterjet specialist Brian Grinnell, are a father and son Index racing team. Lee also turns laps at SCCA track days. || SWPS Project Coordinator, Michael Barbalinardo, races his Mustang in street class, at NJ & PA drag strips. || Southern sales rep, John Konnick, races his S&W Dragster in the South East. || Marketing Director, Jill Fazekas will be making her return to exhibition match racing, in a nostalgia nitro funny car. || Sales Rep. Morgan Mahan crews for a 4X4 truck team and enjoys all forms of motorsports.

Plus, many of our fabricators are racers too. Some burn rubber and others sling clay on the weekends!



LOOK for the Signature Orange S&W Track Side Display at North East Race and Show Events



Check our Site Events Calendar and Social Pages Often.
@SWRACECARS
#SWLiveOnSite



HOW TO ORDER LIKE A PRO!

1. If you are already an S&W Race Cars customer, please Have your customer number ready. If this is your first order with S&W, our sales representative will give you a customer number while you are on the phone.
Please write your Customer # down for future reference.
2. Have your complete Billing & Ship To addresses ready.
3. It is best to ship your order to an address where someone is able to receive it. (Indicate Residential or Commercial)
4. Please have your order ready when you call. Give part numbers whenever possible. If you are uncertain as to the correct parts you need it is best to call the tech & info line (610-948-7303) and have one of the technicians help you with your order.
5. We must have the best phone number to reach you during normal business hours.
6. Prepayment is required before order is processed. Visa, MasterCard, Discover, AmEx credit cards accepted plus PayPal. Bank transfers and money orders are also accepted but could delay your order.

CONTACT US

Toll Free Order Line.....800-523-3353
 Tech & Info.....610-948-7303
 24 Hr. Fax.....610-948-7342

Parts Sales
 Tom Haosigian (General Manager).....126
 Randy Krause (Car Sales & Service Manager).....115
 Morgan Mahan.....120
 Lee Grinnell.....119

Car Sales
 Randy Krause (Car Sales & Service Manager).....115

Marketing
 Jill Fazekas.....112

Engineering
 John Burke.....137

Precision Specialties Division- Commercial Project Coordinator
 Michael Barbalinardo.....133

Accounting Dept.
 Vicki Rothas (CFD).....132

Shipping & Receiving Dept.
 Rich Bilinski (Shipping Manager).....123

PHONE & SHOWROOM HOURS

Note: Hours are subject to change.

Monday - Friday.....8:00am to 6:00pm
 Saturday.....Closed
 Sunday.....Closed

LOCATION

11 Mennonite Church Road - Spring City, PA 19475

We Ship Worldwide!



TERMS & CONDITIONS of SALE

Prices

All prices are subject to change without notice! We cannot accept responsibility for errors in content or pricing.

Returns

No merchandise will be accepted for return without prior authorization! Special orders are not returnable. All return shipments must be prepaid. A 20% handling charge will be applied to any returns. No cash refunds. Credit card refunds 5-7 days to process. No returns accepted 30 days after the invoice date.

Special Orders

All special orders must be 100% pre-paid and are non-returnable and non-refundable.

Orders Outside the Continental United States

All orders must be pre-paid in U.S. dollars. PayPal, Money Orders or Credit Card payment is preferred. Freight charges must be prepaid. Please call for freight charges. Canadian orders are subject to brokerage & GST fees.

Truck Freight

All merchandise shipped by truck must be paid in full before the order can be shipped. Payment by money order or credit card is preferred. Due to more costly residential delivery charges imposed by most motor freight charges, it is preferable to ship all truck freight items to a business address. Handling Fees, Drop Ship & Hazmat Fees may apply to individual items. Your S&W Sales Representative will make you aware of the applicable fees when your order is placed. Additional freight charges incurred at the time of delivery including, but not limited to Liftgate, Residential/Farm areas, Access Gate Entry and Appointment, will be charged to the customers account.

Claims

All merchandise is counted and cleared by quality control prior to shipment. Claims for damage, shortage and loss in transit must be made immediately with freight carrier. Claims for shortage must be made to S&W Race Cars within 5 days of receipt.

Refused Shipments

All expenses resulting from a refused shipment, regardless of reason, will be the responsibility of the customer. Notice will be sent regarding this amount and the amount will be carried as a balance due. Further shipments will not be made until S&W is reimbursed for the expense.

Shipping Info

All orders over \$500.00 require a signature at the delivery address.

USE OF THIS PRODUCT IS ACCEPTANCE OF THE SELLER'S DISCLAIMER OF WARRANTY

~By their very nature, competition components are constantly pushed to their limits. While our components are designed to withstand intense race conditions, it is impossible to control the quality of installation or the varying conditions in which they are used. It for this reason that absolutely no warranty or guarantee is either written or implied. Neither the seller nor the manufacturer will be liable for any loss, damage or injury - direct or indirect - arising from use of or inability to determine the use of any product.

~Before using, the user shall determine the suitability of the product for its intended use, and the user shall assume all responsibility and risk in connection therewith.

~S & W Race Cars makes no guarantee as to the legality for any specific class. S & W Race Cars makes no claims nor does it intend its products to be used in street driven vehicles. Unless specified as such, the parts in our catalog are not bolt on items - the user must have some fabrication skills!

~S&W Race Cars reserves the right to make changes in design, or add to, or improve on their product without incurring any obligation to install the same on product previously manufactured. The Buyer agrees to indemnify and hold S&W Race Cars harmless from any claim, action or demand arising out of an incident to the Buyer's installation or use of products purchased from S&W Race Cars.

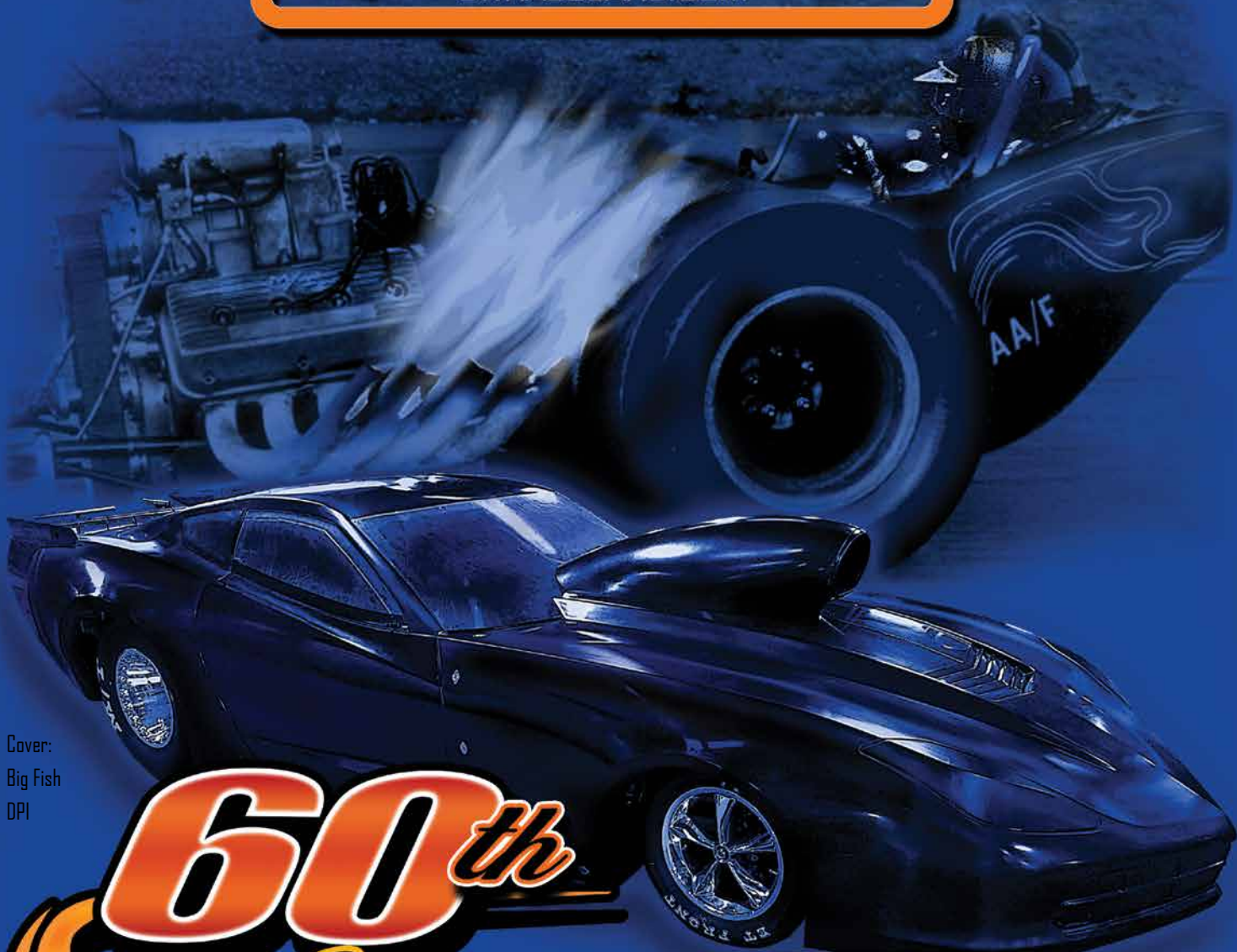

Cover:
Big Fish
DPI

60th Anniversary 1959-2019

S&W Performance Group 1-800-523-3353 **SWRACECARS.com**

 USA Race Car Chassis Builder, Racing Components & High Performance Auto Parts Manufacturing 