

Quantity per assembly:- 1

144,62

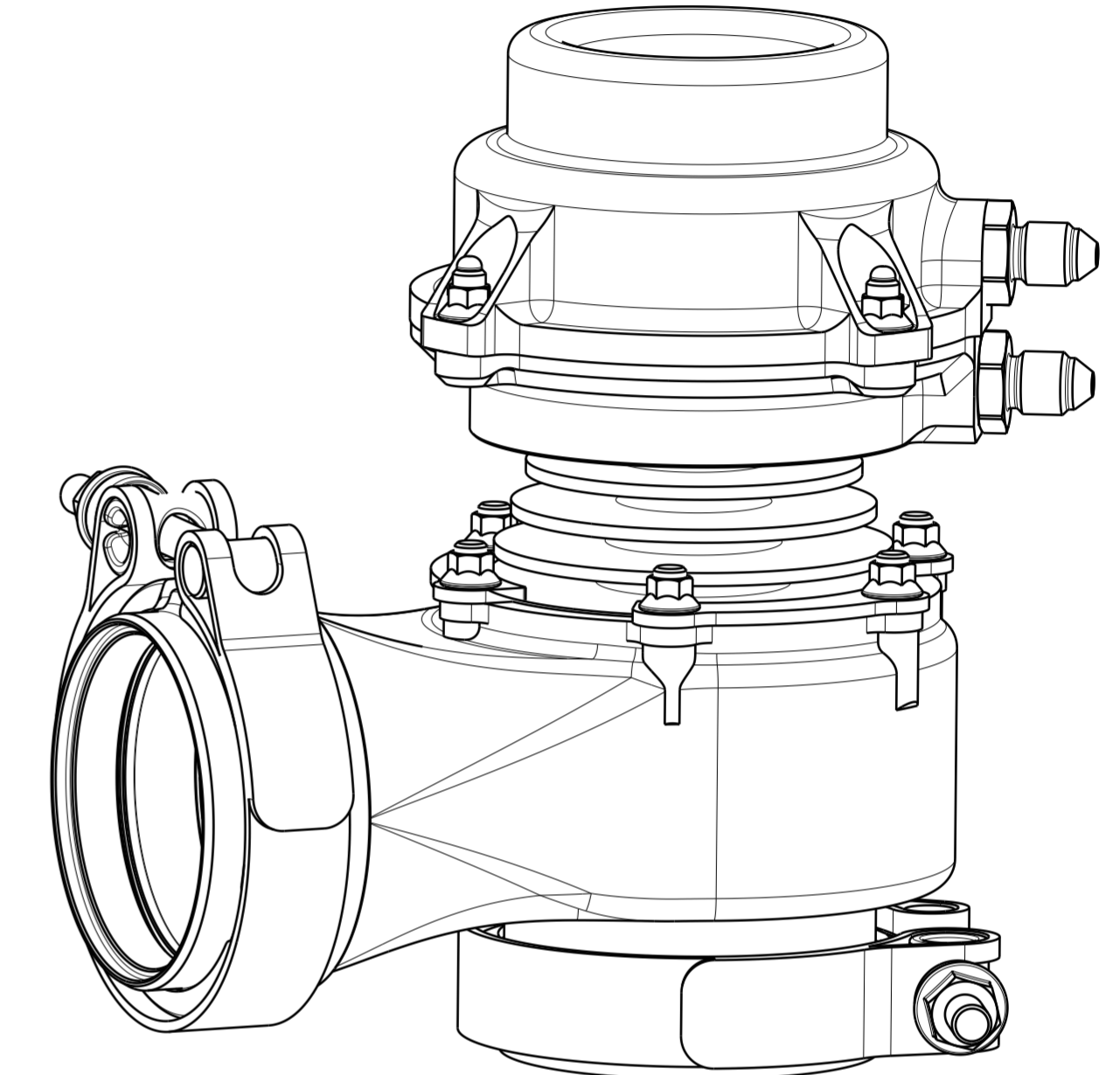
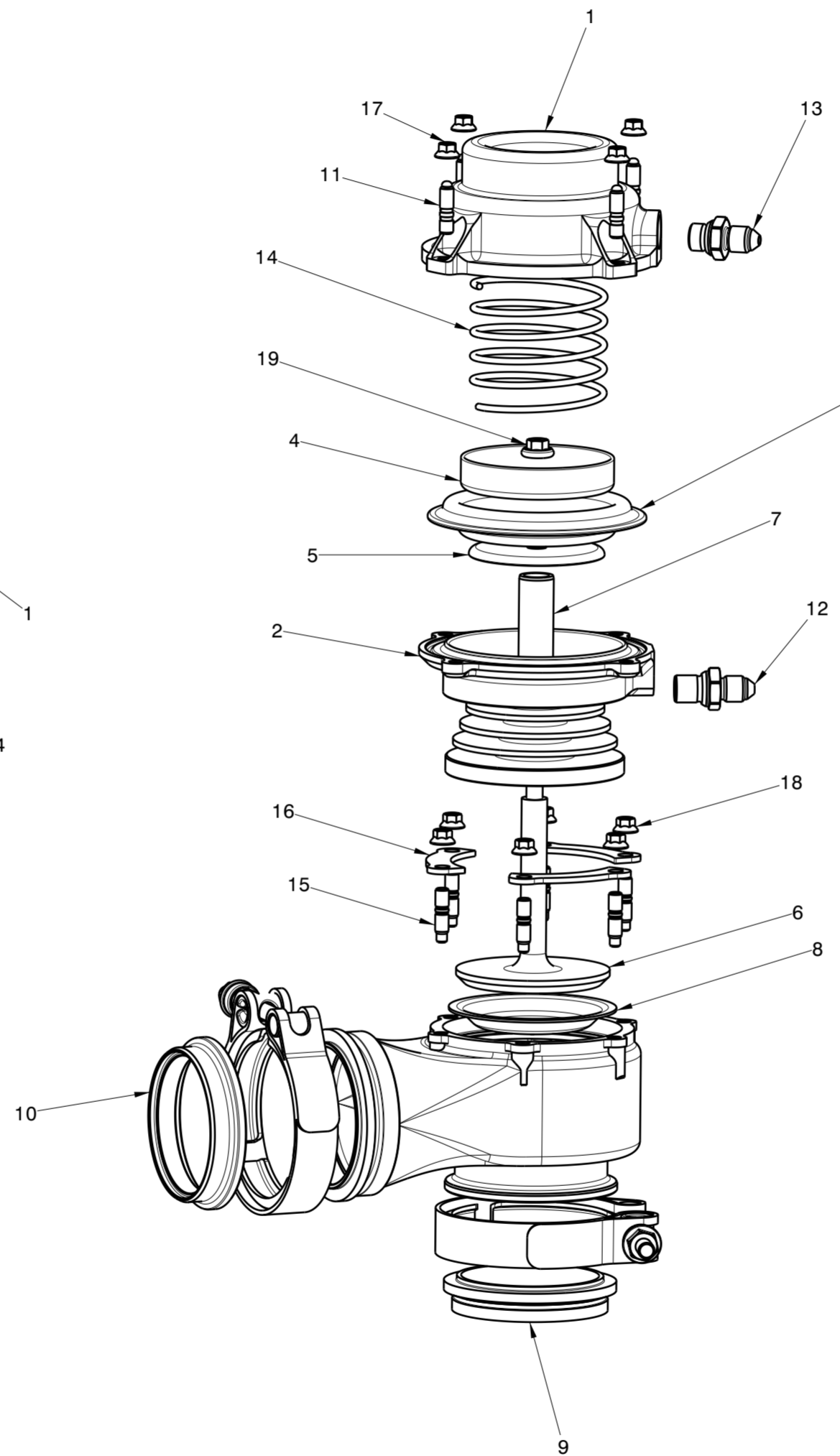
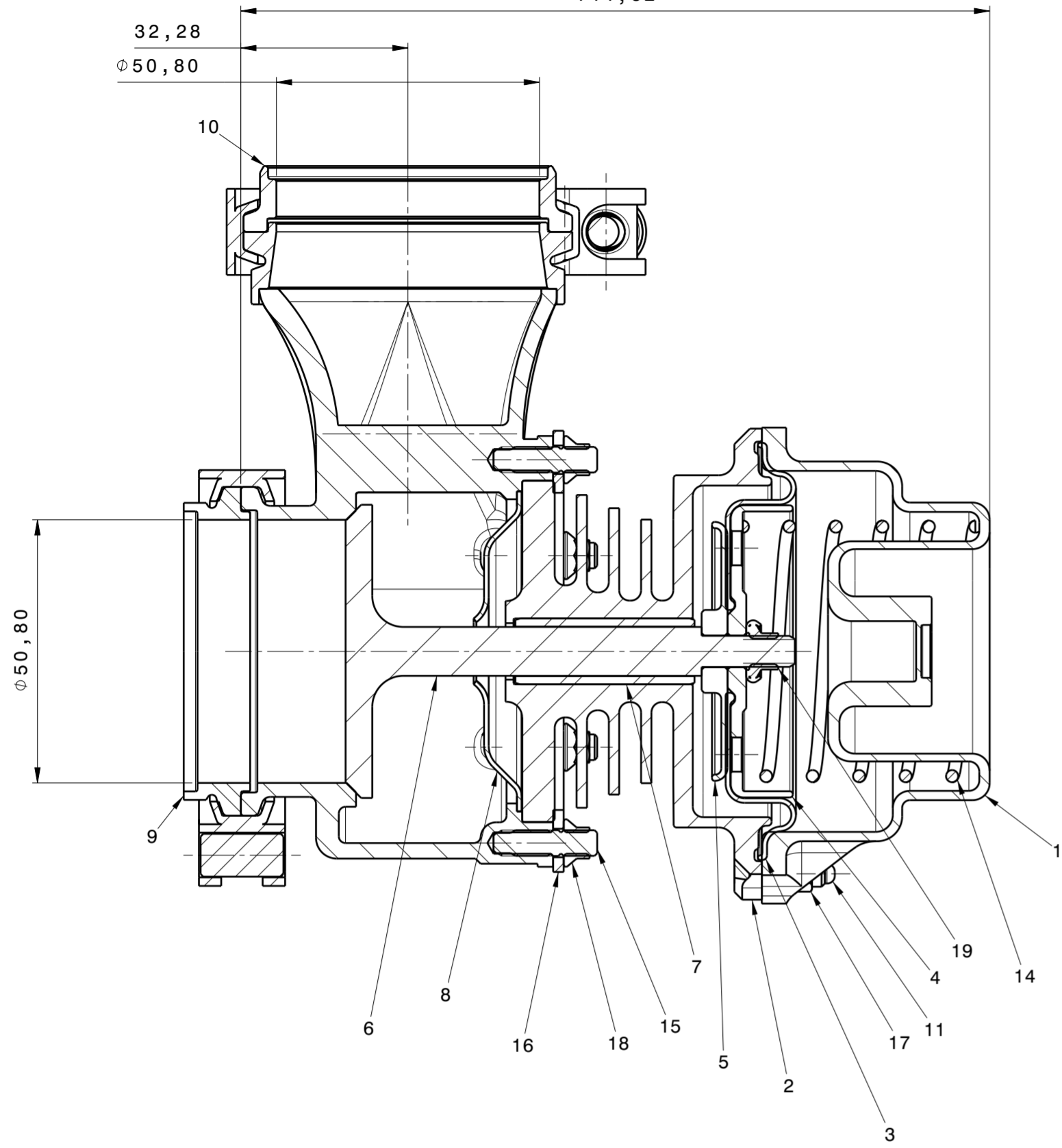

Isometric view  
Scale: 1:1

Bill of Material: 4007-017-111-02

Number	Part Number	Product Description	Quantity
1	194-017-111.	Cap - Centre Port - Spring Top - SGT Wastegate	1
2	196-017-111-01A	Centre Port - Stainless Steel Valve Guide Housing	1
3	125-017-111	Diaphragm - Membrane	1
4	240-017-111	Piston - Diaphragm - Membrane - Stainless Steel	1
5	206-017-111	Clamp Plate - Stainless Steel - Diaphragm - Membrane	1
6	139-017-111	Wastegate Valve	1
7	140-017-111	Valve Guide	1
8	166-017-111	Heat Shield	1
9	199-017-111	Inlet Ring - DW 1 Wastegate	1
10	200-017-111	Outlet Ring - DW1 Wastegate	1
11	113-017-111	Stud - Body To Cap	4
12	131-017-111	Inlet Union -3 Ali Red	1
13	130-017-111	Inlet Union -3 Ali Blue	1
14	154-017-111	Spring - Green Red	1
15	112-017-111	Stud - Casting To Body	6
16	141-017-111	Retaining Plate	3
17	HM14-050	K-Nut - M5	4
18	HM41-050	K-Nut - M5 - Silver	6
19	HWM14-060	Washed K-Nut - M6	1
	DW 0675	Teconnex Clamp Assy	2
	4027-017-111	Wastegate Casting Assy	1

PROCESS.		
No.	Description.	Done.
1	Manufacture.	
2	Inspect.	
3	Part mark as shown.	
4	Record weight.	

02.0	PART 18 CHANGED			SM	PK	PC	26/02/19
01.0	Initial Issue			SM	SM	PC	19/01/17
Issue	Issue Change			Drw.	Chk.	Appr.	Date
Drawing Standard	BS 8888	Unit 7, Park Industrial Estate Frogmore St Albans Herts, AL2 2DR UK					
Material Spec.	N/A	<small>This drawing and the copyright herein, are the property of DPS Engineering Ltd. It is private, confidential and is issued on the express condition that it is not used for any other purpose, copied or communicated to any other party without the written consent of DPS Engineering Ltd. Inspect to this data, then return the drawing and any electronic data with component to DPS Engineering Ltd.</small>					
Heat Treatment Spec.	N/A	General Tolerances Unless otherwise stated	Surface Texture EN ISO 1302 Unless otherwise Stated	CAD Mass (gm) *** Lifed Y/N			
Finish/Protection Spec.	N/A	ISO 2768 -fH	Unspecified Edges ISO 13715	Thread Tolerances Metric 6H(int) 6g(ext) Inch 2B(int) 2A(ext) Service Y/N *			
Description	DW1 - SGT - WASTEGATE ASSY			Part Number As Drawn	Class	Sheet Size	
Drawn	SM	Email: perry@dps.technology Phone Direct: +44 7973 289819		4007-017-111	*	A2	
				Part Number Sym. Opp.	Class	Sheet	
				-	*	1 of 1	