

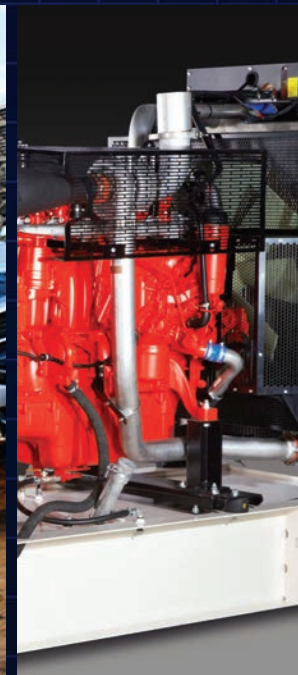

TOTAL SEAL[®]

PISTON RINGS

The Rings. The Tools. The Answers.



RACE | REBUILD | DIESEL | VINTAGE | SPECIALTY | MARINE | AVIATION

EFFICIENCY for Any Engine

Whether it's a stand-alone compressor, an OTR diesel, or simply improving the efficiency of an engine, Total Seal® provides a wide selection of ring sets and custom piston rings for nearly every type of engine on the planet .

Over 50 years ago we invented the Gapless® piston ring that changed the industry. Today, we are much more than Gapless®. We design and manufacture piston rings for every type of internal combustion engine.

Conventional Gap, Gas-Ported, Total Conform™, Diamond Finish™, Gapless® and so many more. Our leading piston ring designs are made from Ductile Iron, Cast Iron, Stainless Steel or Tool Steel. We offer a variety of face coatings including Molybdenum, DLC and multiple PVD coatings.

These design and content options allow us to tailor ring sets to the specific needs of an engine. As a result, that engine runs more efficiently.

Our piston rings have been improving the efficiency of race engines in every form of motorsports for decades, but we also do it for compressors and aviation engines. Utilizing piston ring design to greatly increase engine efficiency is what we do best.

If engines work to make profit for your company, we can help those engines make more money for you. We'd love to discuss any of the options presented in the following pages with you.

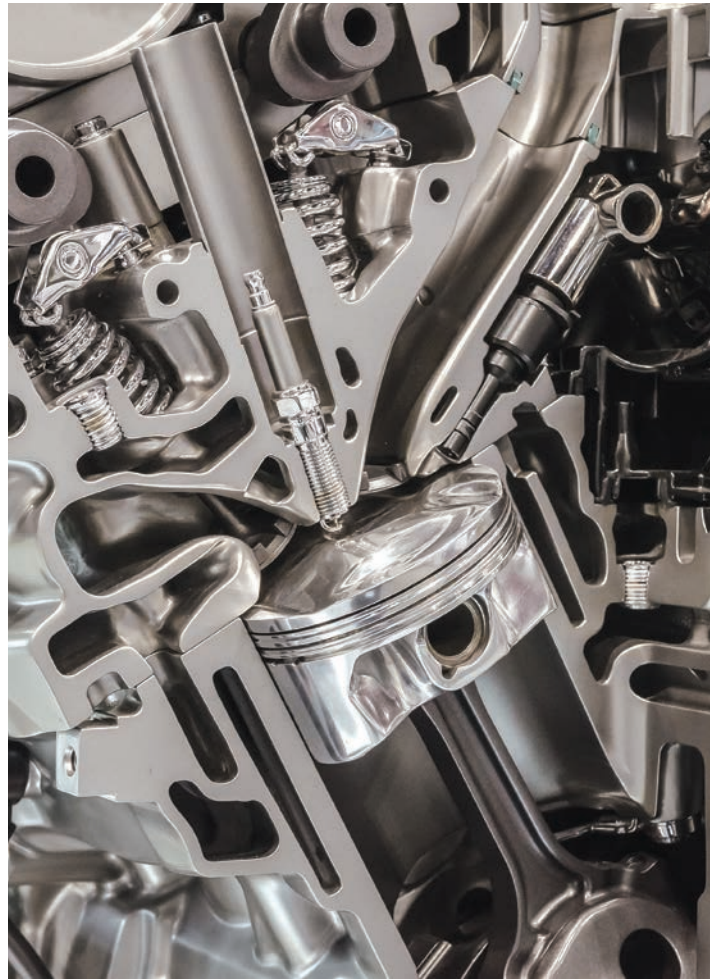

Any piston can only perform as well as the rings surrounding it perform.

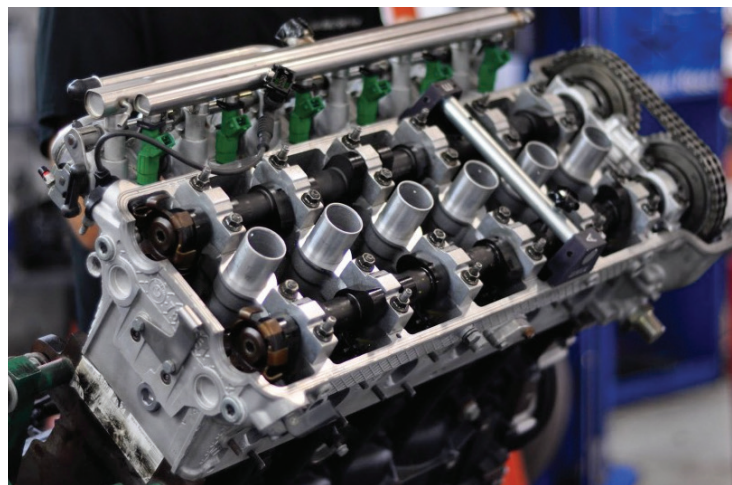

CUSTOM RING Production

Custom Rings - Made To Order

If our inventory of over 10,000 ring sizes doesn't fit your application, we can produce rings specific to your needs, and we don't require minimum runs of 100,000 pieces.

Our in-house engineering, design and manufacturing on our own custom machinery allows us to turn your order quickly, efficiently and perfectly - every time.

Total Seal® supplies Made To Order rings to keep your equipment not only running, but running more efficiently.

We Offer:

- Reproduction of existing rings
- Production from drawings
- Designed from scratch

Contact us today to get a free quote.
info@totalseal.com or 623-587-7400

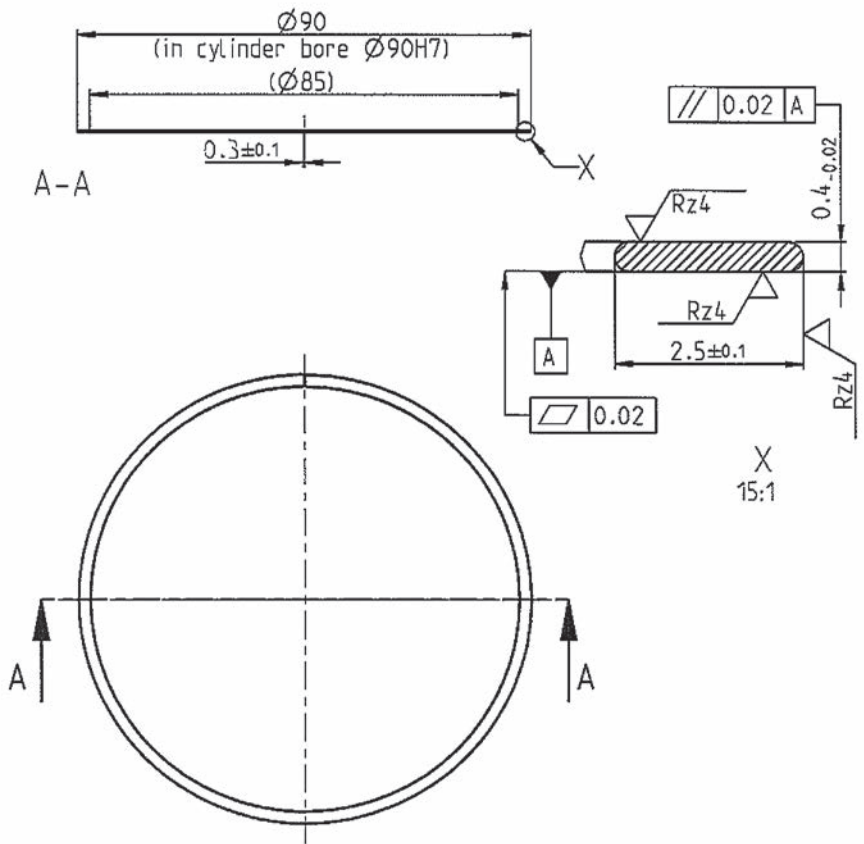

Our state-of-the-art production equipment allows precision manufacturing of short runs of custom rings

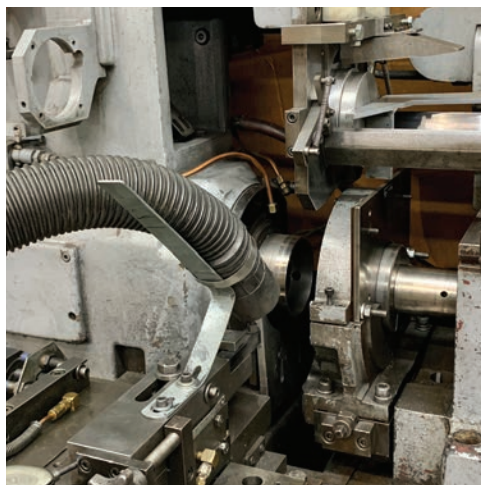

GAS-PORTED Piston Rings

Unlock Hidden Horsepower with Gas-Ported Rings

The primary job of the piston ring is to create the seal between the piston and the cylinder wall. Our new Gas-Ported piston rings represent an evolution in ring seal. The conventional practice of thick, heavy, high tension rings that fought against cylinder pressure to maintain seal has been revolutionized. Instead of fighting cylinder pressure, gas ported rings harness those forces and use them to improve ring seal. These advanced rings benefit all engines, especially turbocharged and supercharged engines.

- Gas-ported performance without the need for gas-ported pistons
- Features strategically sized and placed horizontal slots in the ring allowing combustion gas to enter through the groove and behind the ring to gas-load the ring providing greatly improved ring sealing.
- Extensively tested in virtually every form of engine with the same increases in ring sealing time after time.
- Applications are available in both steel and ductile iron for top ring placements. When ordering simply ask for Gas-Ported on your top ring sets.

Available in all popular standard and metric bore sizes:

- Including 1.0mm x 1.0mm x 2.0mm ring combinations
- Including 1.0mm x 1.2mm x 2.8mm ring combinations
- Including 1.2mm x 1.2mm x 3.0mm ring combinations

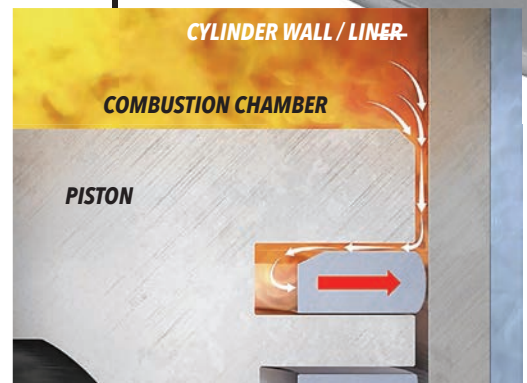
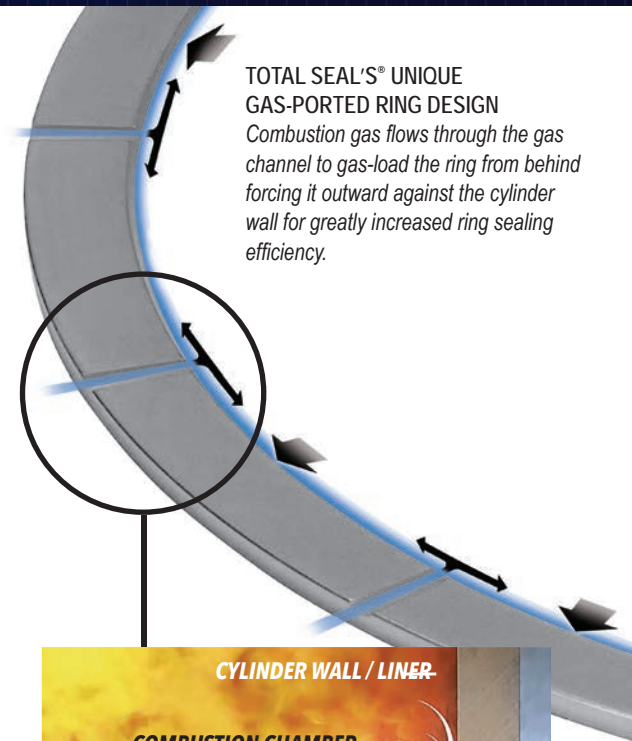

A Simple Ring Upgrade Provides Proven Performance Gains:

- Better Ring Seal
- More Horsepower
- Less Blow-By
- Can Be Used with Gas-Ported Pistons

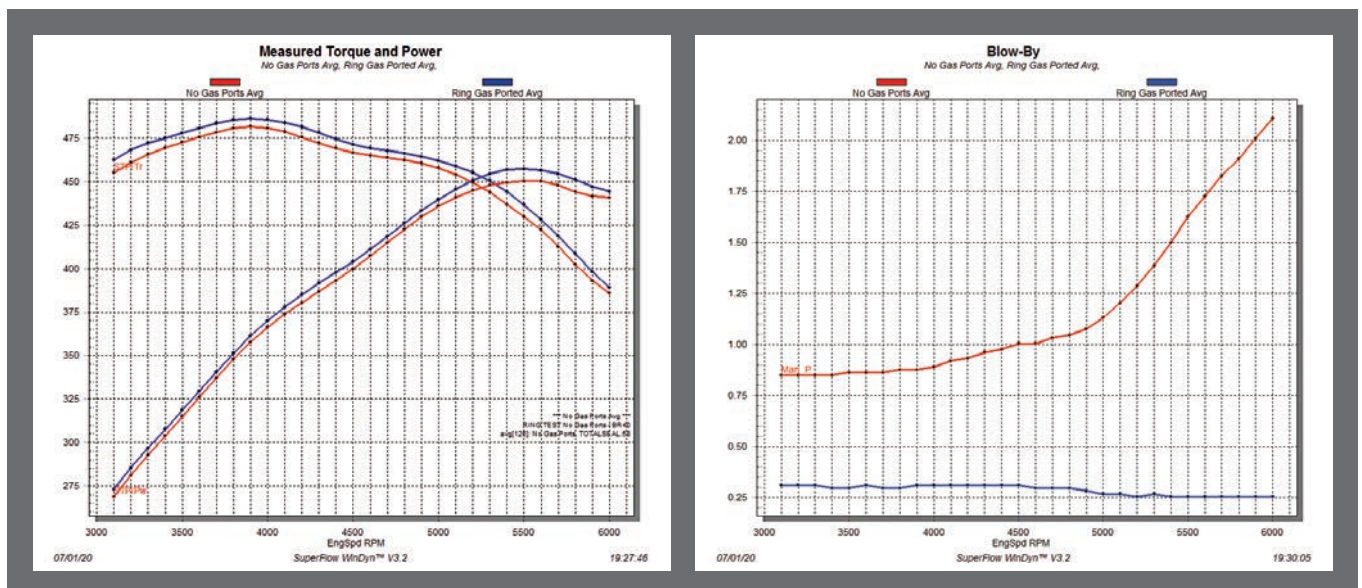

Proven increased horsepower and reduction in blow-by

GAPLESS[®] DIESEL Piston Rings

Gapless[®] Piston Ring Technology Isn't Just For Racing

Soot contamination increases engine wear and decreases oil life. Closing the gap on the 2nd ring stops soot contamination and reduces blow-by. Since diesel engines utilize high compression ratios, Total Seal[®] Gapless[®] second rings help these engines unleash their full potential, turning them into true horsepower and torque monsters.

- Better Sealing = More Boost
- Increased Horsepower & Torque
- Reduced Oil Contamination
- Cooler Running Engine Oil

Sets available for:

- 5.9L Cummins
- 6.6L Duramax
- 6.7L Cummins
- Ford Powerstroke - 6.4L to 7.3L
- Custom sets also available

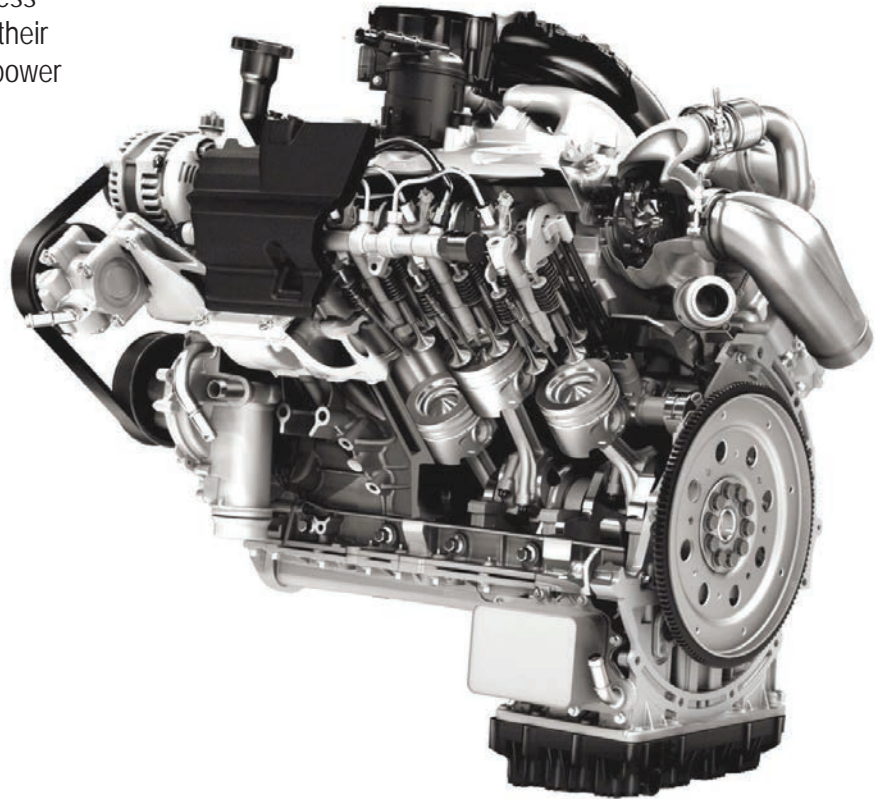

MAXIMIZING Ring Seal

Maximum engine performance requires maximum piston ring seal.

Advancements in piston ring technology have changed the way an engine block needs to be honed to achieve maximum ring seal.

PROBLEM - Over 40% of all engine friction is generated by the piston ring to cylinder wall contact. An incorrect surface won't properly seal or provide lasting durability. To properly seal, support the load, and hold oil for lubrication, the cylinder surface requires a specific texture. So how do you know what that texture should be and how can you make sure the honing process created that texture?

PROBLEM SOLVED - Total Seal knows what that surface texture needs to be, and we have the tools to properly measure cylinder bore texture. As the leaders in ring seal technology, we can specify cylinder bore textures based on the ring material and engine application (boosted vs. NA, gasoline vs. methanol, etc.) Once the proper texture is chosen, how do you know it was achieved? That's why we developed the new Microscope & Profilometer kit to precisely measure and validate cylinder bore surface texture.

Total Seal® Surface System (shown at right)

Go beyond the "numbers" to achieve greater horsepower and durability. The Surface System from Total Seal provides both surface finish and cross hatch measurement in one package. It's the first and only complete system for measuring, seeing and saving surface finish data.

Easy to use, all-in-one kit includes:

- Zeiss HandySurf+ Profilometer
- USB Microscope
- TraceBoss Software
- HatchView Software
- Asus Laptop (everything pre-installed and ready to use)
- Profilometer Locating Tool
- Reference Scans
- Resource Library

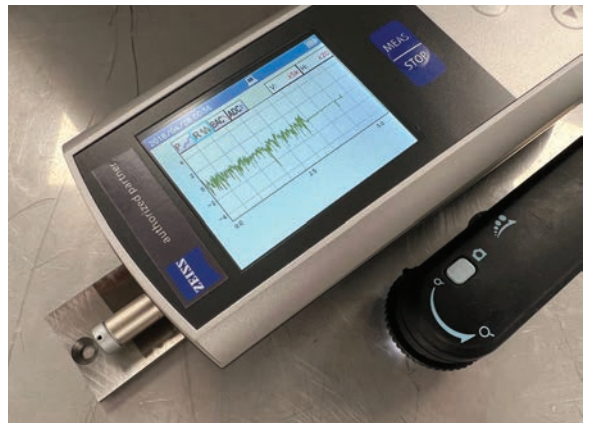

To Achieve maximum Ring Seal, using Total Seal® Piston Rings are the first part of the equation. The right cylinder bore surface finish is the other.

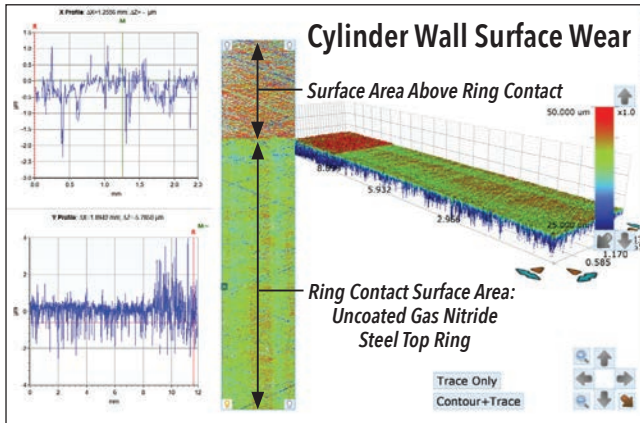

These Optical Profilometer scans show the extreme contrast in cylinder surface wear between using noncoated steel rings (above) vs. coated steel rings (below).

ABOVE: The green area is the uncoated ring contact wear compared to the red non contact area above it.

BELOW: The red area shows virtually no difference in surface wear caused from the coated steel ring.

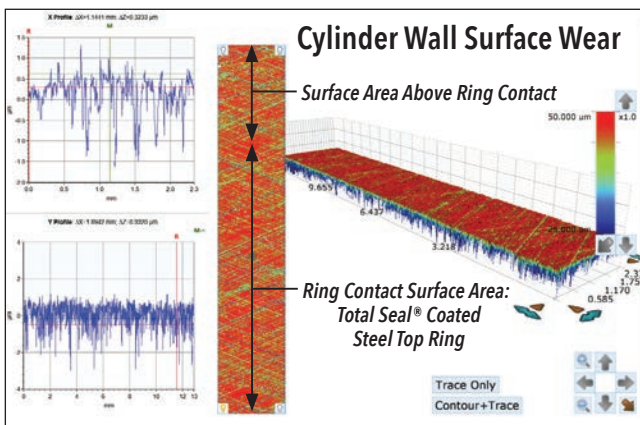

The ring contact and cylinder surface must work in harmony to reduce friction and extract the full performance potential out of the engine. The Total Seal® Surface System is the first and only complete all-in-one kit for measuring, seeing and saving cylinder bore surface finish data. Total Seal® provides the rings, the tools and the answers that enable more horsepower and greater durability.



Assembly TOOLS

At Total Seal®, Precision and Selection Doesn't Stop With Our Piston Rings

We don't just make the world's most efficient piston rings. We are with you all the way to the completed, running engine.

From Ring Squaring Tools to Leak Down Testers, from Profilometers to our Power Ring Filer, we source the finest, or build our own design tools to finish the job right.

- Power Ring Filer
- Custom Sized Ring Compressors
- Adjustable Ring Compressors
- 2-piece design Split Ring Compressors
- Ring Squaring Tools
- Ring Installation Pliers
- Leak Down Tester
- Profilometer Surface System
- Quick Seat Assembly Lube



DIGITAL Resources

Total Seal® not only makes piston rings tailored to meet all your needs, we also provide tech support for the way you work. Besides an outstanding tech support phone line manned by seasoned engine specialists, we also produce a variety of digital tech resources:

- Highly acclaimed Hidden Horsepower podcast
- Newly redesigned website w/online catalog
- YouTube Channel w/tech videos
- Social Media accounts - Instagram, Facebook, LinkedIn



Please fill out the Request a Ring Form on our web site and tell us all about your needs. We will get back to you right away.

Or call us now at 1-623-587-7400 and speak directly to our Tech Department.

TOTAL SEAL

PISTON RINGS

Phone: 623-587-7400

Email: info@TotalSeal.com

Web: www.TotalSeal.com