

HELLIX

AUTOSPORT

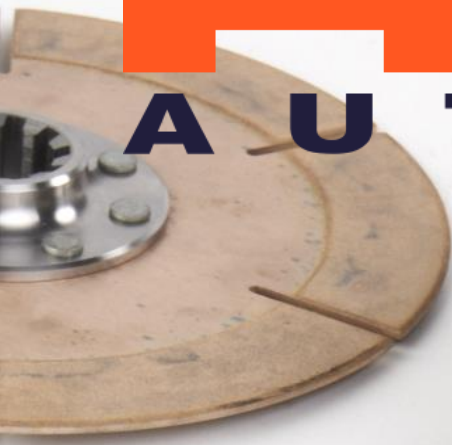

Contents

Part Number Legend	3
The HELIX Racing Clutch Range	5
Clutch Terminology	6
Clutch Fitting & Flywheels.....	7
Clutch Installation Drawing.....	8
Release Bearings	9
Race Series Release Bearings	10
40-3000 40-3001.....	10
40-3000A 40-3001A	10
Concentric Slave Cylinder Release Bearings	11
Clutch to Flywheel Mounting Bolt Kits.....	12
184mm 'Ø' HELIX Racing Clutch Range	13
62-130	17
62-220	18
63-110	19
63-110c	20
63-120	21
63-120c	22
63-130	23
63-130c	24
63-210	25
63-210c	26
63-220	27
63-220c	28
63-230	29
63-230c	30
63-230 Short	31
184mm Ø Sintered, Cerametallic & Organic Drive Plate Hub Spline Details	32
200mm Ø 'Helix' Racing Clutch Range	36
68-110	39
68-110c	40
68-120	41
68-120c	42
200mm Ø Cerametallic & Organic Drive Plate Hub Spline Details	43

215mm Ø 'HELIX' Racing Clutch Range 47

 69-110 48

 69-110c 48

 69-120 48

 69-120c 48

215mm Ø Cerametallic & Organic Drive Plate Hub Spline Details 48

Part Number Legend

<u>Prefix Number</u>	<u>Description</u>
40-....	Release Bearing
41-....	Concentric Slave Cylinder/Release Bearing
43-....	Release Bearing for 184mm acing Clutch (on standard carrier)
44-....	Release bearing for 200mm & 215mm Racing Clutch (on standard carrier)
46-....	215mm Geared Hub Drive Plates
47-....	200mm Geared Hub Drive Plates
48-....	184mm Geared Hub Drive Plates
49-....	184mm 6 Paddle Cerametallic Drive Plate
51-....	184mm 3 Paddle Cerametallic Drive Plate
52-....	184mm 4 Paddle Cerametallic Drive Plate
53-....	184mm Sintered Drive Plate (Outer)
54-....	184mm Sintered Drive Plate (Inner)
55-....	184mm Organic Drive Plate Rigid
56-1...	184mm 3 Paddle Cerametallic Drive Plate
56-2...	184mm 4 Paddle Cerametallic Drive Plate
57-....	184mm Organic Drive Plate (sprung hub)
63-....	184mm Lug Drive Cover Assembly
68-....	200mm Lug Drive Cover Assembly
69-....	215mm Lug Drive Cover Assembly
70-1...	200mm Organic Drive Plate (sprung hub)
70-2...	215mm Organic Drive Plate (sprung hub)
71-....	215mm Organic Drive Plate (rigid hub)
71-1...	200mm Organic Drive Plate (rigid hub)

Part Number Legend

<u>Prefix Number</u>	<u>Description</u>	
71-2...	215mm Organic Drive Plate (rigid hub)	
71-3...	215mm Organic Drive Plate (rigid hub)	
77-1...	200mm 4 Paddle Cerametallic Drive Plate	(sprung hub)
77-11..	200mm 6 Paddle Cerametallic Drive Plate	(sprung hub)
77-2...	215mm 4 Paddle Cerametallic Drive Plate	(sprung hub)
77-21..	215mm 6 Paddle Cerametallic Drive Plate	(sprung hub)
78-1...	200mm 4 Paddle Cerametallic Drive Plate	(rigid hub)
78-11..	200mm 4 Paddle Cerametallic Drive Plate	(rigid hub)
78-2...	215mm 4 Paddle Cerametallic Drive Plate	(rigid hub)
78-3...	215mm 4 Paddle Cerametallic Drive Plate	(rigid hub)
78-21..	215mm 6 Paddle Cerametallic Drive Plate	(rigid hub)
78-31..	215mm 6 Paddle Cerametallic Drive Plate	(rigid hub)

The HELIX Racing Clutch Range

The range has been designed to satisfy the needs in the competition market, with a variety of customisation available for all sections of the market.

The racing clutch covers are a one piece aluminium design, this benefits from improved heat dissipation compared with more traditional steel covers. The covers also benefit from a comparatively lower moment of inertia when compared more traditional designs.

The following drive plate configurations are available:-

Sintered Rigid Hub

Ceramic rigid Hub (Paddle Clutch)

Ceramic Sprung Hub (Paddle Clutch)

Organic Rigid Hub

Organic Sprung Hub

The customer defined configuration is dependent on application and engine torque output. This will determine the clutch diameter and number of plates required. The information offered here will aid in making the decision, but if required technical information is available from Helix.

Ceramic & Organic clutches are available in 1 & 2 plate versions diameter 184, 200 & 215mm

Sintered clutches are available in 1, 2, 3, & 4 plate versions, however these only come in 184mm diameter variants.

Drive Plate Material Explained.

Organic

- Better Suited to road applications
- Can be used for light competition
- Offers the softest engagement
- Least prone to judder
- Lightweight – low moment of inertia
- Compact installation
- Available in both rigid and sprung hub formats

Sintered

- used primarily in race applications.
- compact dimensions
- Lightweight – Low moment of inertia
- Well suited for Rallying application's

Ceramic

- Primarily used for rally applications
- Also used for race applications especially with a diameter over 184mm.
- Can be used for road use where engine torque requires it
- Greater resistance to high energy input
- Smoother engagement than sintered material plates
- Less prone to judder than sintered material plates
- Available in both rigid and sprung centre formats

Clutch Terminology

Cover Assembly – Push Type

This is the most common type of clutch cover assembly where in operation the release bearing pushes the diaphragm spring inwards towards the flywheel in order to release the clutch.

Cover Assembly – Pull type

With the pull type the release bearing is attached to the diaphragm spring and pulls the spring away from the flywheel towards the gearbox to release the clutch.

This type has a lower release load due to its longer lever ratio and given that the diaphragm spring is not being pushed over centre. The design is more efficient and gives a higher clamp load to release load ratio than a push type clutch.

Diaphragm Spring

A Belleville disc spring with a series of fingers pointed inwards. The inside of the Belleville is where the release bearing operates the spring. This is available in different thicknesses / load deflection curves for different torque capacities.

Clamp Load

The pressure / force applied by the diaphragm spring onto the drive plate via the pressure plate and intermediate plate (drive plates). The force applied being determinate on the strength of the spring and the fulcrum ratio of the pressure plate

Release Load

The force required by the release bearing operating on the diaphragm spring to disengage the clutch

Pressure Plate

This is the metal disc with a raised fulcrum point for the transmission of the clamp load to the drive plate from the diaphragm spring.

Interplate

An intermediate pressure plate which is positioned between the drive plates in a multi plate clutch system. A typical two drive plate setup would have one pressure plate and one Interplate where as a three drive plate system would feature one pressure plate and two interplates.

Moment of Inertia

The rotating mass around the centre axis of the clutch, the smaller diameter the lower the moment of inertia, which will give a faster response in engine pick up and gear changes.

Set up Height (S.U.H.)

The dimension from the contact point of the release bearing on the diaphragm spring to the friction face of the flywheel (Cover SUH). For a whole kit setup height, the measurement is taken from the crank shaft mounting face.

Clutch Fitting & Flywheels

The racing clutches are fitted to the flywheel by either :-

The preferred / recommended method

High quality bolts / mounting studs passing through from the rear of the flywheel.

These need to be a close tolerance push fit through the flywheel with a locating spigot machined on the rear of the flywheel to prevent rotation of the bolts / mounting studs.

These are retained by K-lock nuts. Recommended torque settings 22Nm [16lbft]

See relevant clutch diameter section for dimensions and torque figures.

Or by :-

High quality socket head cap screws (min tensile 10.9) diameter 8mm or 5/16" located through the cover assembly and screwed directly into the flywheel.

In using this method it is important that a counter bore is used to ensure the shear load

Through the screw is across the full shank diameter and NOT the thread.

Recommended torque settings 22Nm [16lbft]

See relevant clutch diameter section for dimensions and torque figures

Flywheels

These clutches can be fitted to existing cast iron O.E. flywheels but these should not be used above 8000rpm. It is not advisable to modify dual mass flywheels except where there is no other option and in which case these should not be used above 6500 rpm.

It is recommended that a high quality purpose made steel flywheel be used material to be of 0.35 / 0.45 carbon with a minimum hardness of 200Hb minimum

The run out of this flywheel when fitted to the crankshaft must not exceed 0.08mm at 76mm radius.

See relevant clutch diameter section for dimensions and torque figures

Maintenance

It is advised that regular inspection and maintenance is carried out to ensure the clutch operates to its optimum performance.

Pressure plates should be checked for coning and replaced when more than 0.15mm out of flat, otherwise the clutch can drag interfering with clutch release.

Driven plates should be replaced if showing signs of damage or if the minimum thickness has been reached (see the relevant clutch diameter section for details)

Clutch Installation Drawing

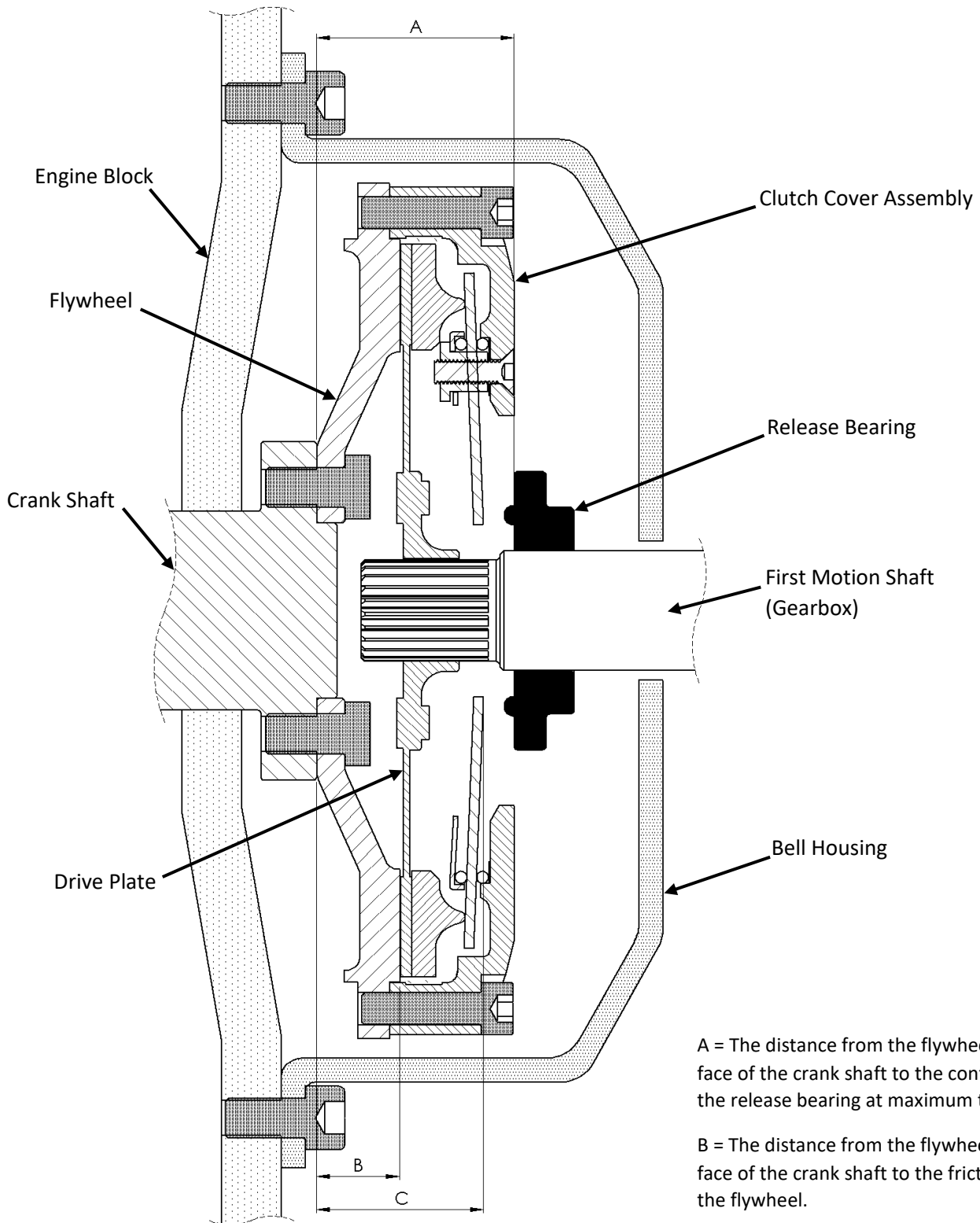

A = The distance from the flywheel mounting face of the crank shaft to the contact face of the release bearing at maximum travel.

B = The distance from the flywheel mounting face of the crank shaft to the friction face of the flywheel.

C = Kit Set Up Height, the distance from the flywheel mounting face on the crank shaft to the contact point of the release bearing on the diaphragm spring.

When fitting a non-standard clutch & flywheel as a replacement for the original certain parameters must be measured. As shown above A, B & C are taken to ensure the replacement kit operates correctly.

If you are unsure about the replacement process or would like to enquire about a custom clutch design please contact the design team.

Release Bearings

The release bearings should be a high quality steel caged radius contact ball bearing with a fulcrum diameter of :-

- 48 → 52mm for a clutch of \varnothing 140mm
- 48 → 54mm for a clutch of \varnothing 184mm
- 52 → 54mm for a clutch of \varnothing 200mm & 215mm

On fitting the release bearing it should be arranged so that the bearing is not in contact with the diaphragm spring fingers when the clutch is fully engaged. Constant contact will result in excessive wear on both the diaphragm spring fingers and the release bearing.

It is also IMPORTANT that the travel of the bearing when operated is to a controlled distance otherwise damage to the diaphragm spring can occur, this travel can be limited by means of an external stop. See relevant clutch part # for dimension.

HSHP = High Speed / High Performance

Bearings available

Part No	Dimension \varnothing A	Dimension \varnothing B	Dimension C	Dimension \varnothing D
40-1252	74.00mm	45.00mm	18.00mm	54mm
40-2429	67.00mm	40.00mm	19.70mm	52mm
40-3000	65.00mm	35.00mm	18.50mm	48mm HSHP
40-3001	70.50mm	40.00mm	19.00mm	54mm HSHP
40-3264	68.50mm	38.00mm	19.00mm	52mm
40-4941	63.00mm	40.00mm	14.00mm	51mm

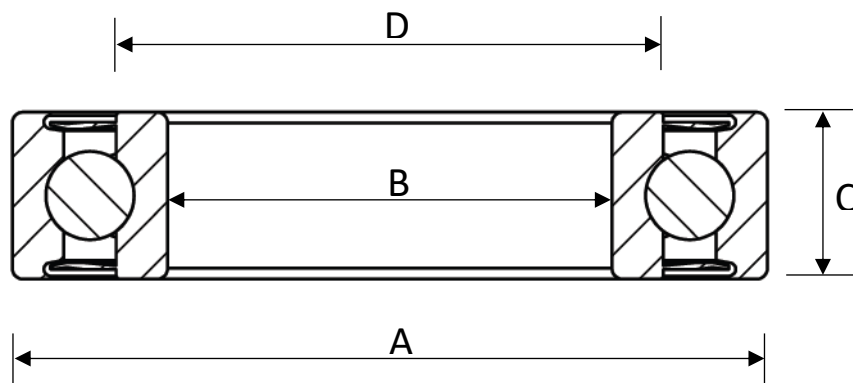

Clutches fitted with an O.E. concentric slave cylinder operating system will require this being replaced with a more robust system and not just a release bearing.

For the fitment of 184mm clutches to BMW vehicles special bearings are available :-

- 40-3002 for gearboxes with a 28mm x 10teeth spline
- 40-3003 for gearboxes with a 28mm x 22teeth spline
- 40-3004 for gearboxes with a 35mm x 10teeth spline

Race Series Release Bearings

Helix Autosport offer a range of release bearings to accompany the race cover series. These are manufactured to withstand the demanding conditions a competition clutch is exposed to.

All release bearings feature a curved contact face to be used with our flat diaphragm spring covers.

40-3000

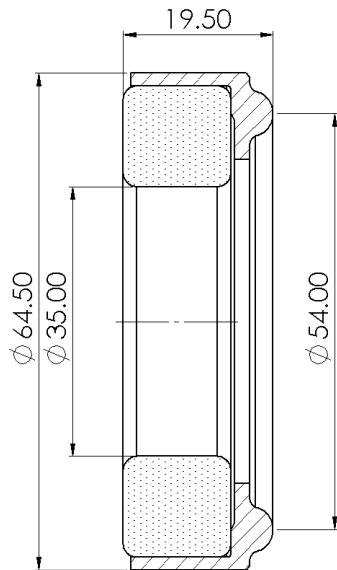

40-3001

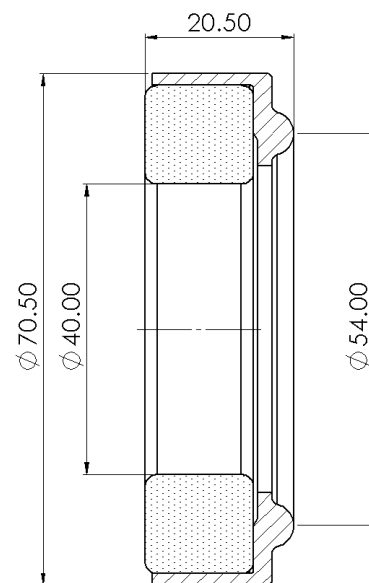

40-3000A

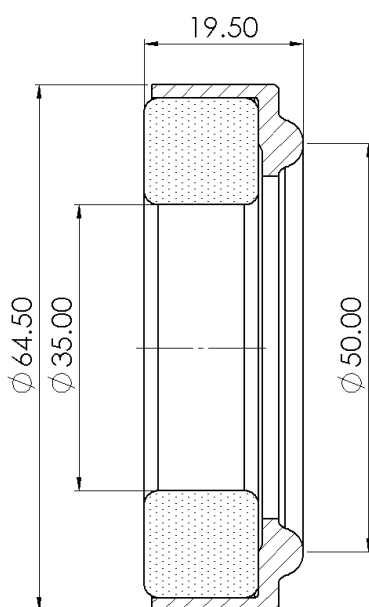

40-3001A

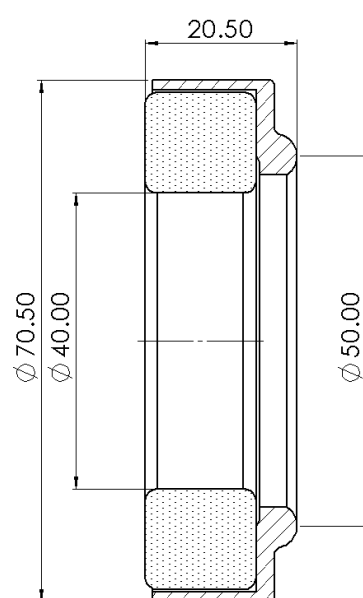

Concentric Slave Cylinder Release Bearings

Clutches fitted with an O.E. concentric slave cylinder (CSC) operating system will ideally require being replaced with a more robust system and not just a release bearing.

If the CSC has a flat contact face we offer a range of curly tipped diaphragm spring clutch covers. These are identified by a 'c' at the end of the part number e.g. 62-220c.

Cover assemblies with curly tipped springs (with suffix c)

Ø184mm Racing Clutch

63-110Bc, 63-110Rc, 63-110Gc, 63-110Yc

63-120Bc, 63-120Rc, 63-120Gc, 63-120Yc

63-130Bc, 63-130Rc, 63-130Gc, 63-130Yc

63-210Bc, 63-210Rc, 63-210Gc, 63-210Yc

63-220Bc, 63-220Rc, 63-220Gc, 63-220Yc

Ø200mm Racing Clutch

68-110Rc, 68-110Yc

68-120Rc, 68-120Yc

Ø215mm Racing Clutch

69-110Gc, 69-110Yc

69-120Gc, 69-120Yc

All 'C' suffix model covers are the same configuration and performance as non-C suffix models.

Please Note: Setup heights of C suffix models are increased by around 3mm.

Clutch to Flywheel Mounting Bolt Kits

Helix Autosport can supply mounting bolts to attach the range of racing clutches to the flywheel.

These bolts are rated at 10.9 tensile strength with a 5/16" UNF thread. All kits are packed in multiples of 6 bolts with the matching locking 'K' nuts.

Single items or multiples thereof can be supplied.



184mm 'Ø' HELIX Racing Clutch Range

Series Part No. 63-100 & 63-200



Cover Assembly is of a lug drive configuration one piece aluminium alloy. This design allows the dust from the friction material to escape and reduces the heat build up. These are used with either sintered, cerametallic or organic faced drive plates in 1 to 3 plate formats.

Series Part No. 53-1000 & 54-1000



Sintered Drive Plates have a thin layer of metallic friction material bonded to on to both sides of the metal disc. The very nature of this construction means this is normally used for circuit racing only.



This format is available as either a full circle with six thin slots or as a six spoke version for more arduous applications.

Series Part No. 53-2000 & 54-2000

Series Part No. 55-1000



Heavy duty organic faced drive plates with a rigid centre hub give a more progressive engagement of the clutch (compared to sintered or cerametallic clutch designs) enabling more control in clutch take up. Available in either single or twin plate formats.

Series Part No. 57-1000



Heavy duty organic faced drive plates with a sprung centre hub to give the most progressive engagement possible with this design of clutch. Only available as a single plate clutch.

Series Part No. 49-1000, 51-1000 & 52-1000



Cermetallic Paddle Drive plates have cermetallic segments riveted onto a steel back plate. These are thicker than the sintered type to give a higher heat capacity, while also giving improved heat dissipation where a greater level of clutch slip is required.

This design is used mainly for rally applications although it can be used very successfully for racing, especially endurance applications.



This format is available in:-

3 paddle type -- Series part No. 51-1000

4 paddle type -- Series part No. 52-1000

6 paddle type -- Series part No. 49-1000



Note :-

See separate sheet for all hub spline configurations available as standard.

Any spline can be manufactured but there will be a short time delay and extra cost.

Series Part No 56-1000 & 56-2000



Sprung centre cermetallic drive plate has the same properties as the rigid cermetallic drive plate, but with the addition of damper springs to cushion the impact of clutch engagement on the driveline components.

Only available as a single plate clutch.



3 paddle type -- Series part No.56-1000

4 paddle type -- Series part No 56-2000

Series Part No 62-100 & 62-200



Pull Type Design machined from aluminium billet is more efficient than a push type clutch unit.

These are of a less complicated construction and are therefore lighter and give a more consistent operation with better feel.

The Lug drive configuration allows the dust from the friction material to escape and reduces the heat build up. These are used with sintered or cerametallic drive plates.



Series Part No 63-100TP & 63-200TP

Cover Assembly design and dimensions as per 63-100 & 63-200 series but fitted with a release plate to facilitate the use of a flat face release bearing



Series Part No 48-2000 & 48-2090

Sintered drive plates with a main geared hub (48-2000) and floating hub drive plates (48-2090) either twin or triple



Series Part No 48-3001 & 48-2093

Organic drive plates with a main geared hub (48-3001) and floating hub drive plate

(48-2093) shown as a set



Series Part No 48-1001 & 48-2091

Cermetallic 4 paddle drive plates with a main geared hub (48-1001) and floating hub drive plate (48-2091)



Series Part No 48-1101 & 48-2092

Cermetallic 6 paddle drive plates with a main geared hub (48-1101) and floating hub drive plate (48-2092)

62-130

Ø184mm, Triple Sintered Drive Plate



Cover Torque Capacity

62-130R	945Nm	[695lb/ft]
62-130G	1428Nm	[1050lb/ft]

Cover Release Load Release Bearing Travel (Max)

62-130R	250Kg	7.00mm
62-130G	318Kg	

Set-Up Height (New)

62-130R	37.80mm
62-130G	38.10mm

Set-Up Height (Worn)

62-130R	34.80mm
62-130G	35.15mm

Drive Plates

	Series Part No	Thickness New [Nom]	Thickness Worn [Min]		Weight
Sintered (Rigid)	53-1000	2.66 mm	2.34 mm	[See chart for spline details]	4.6 Kg
Sintered (Rigid)	54-1000	2.66 mm	2.34 mm	[See chart for spline details]	4.6 Kg
Sintered (Rigid)	53-1000A	2.66 mm	2.34 mm	[See chart for spline details]	4.6 Kg
Sintered (Rigid)	54-1000A	2.66 mm	2.34 mm	[See chart for spline details]	4.6 Kg

Other configurations available see index.

Spare Parts

Wear Clips	184-61C
Pressure Plate	184-17
Interplate	184-11 (x2)
Flywheel Fixing Kit	184-1C

Applications

Sintered Rigid Hub Race

Release Bearing: Depends on vehicle fitment – Please state when ordering.

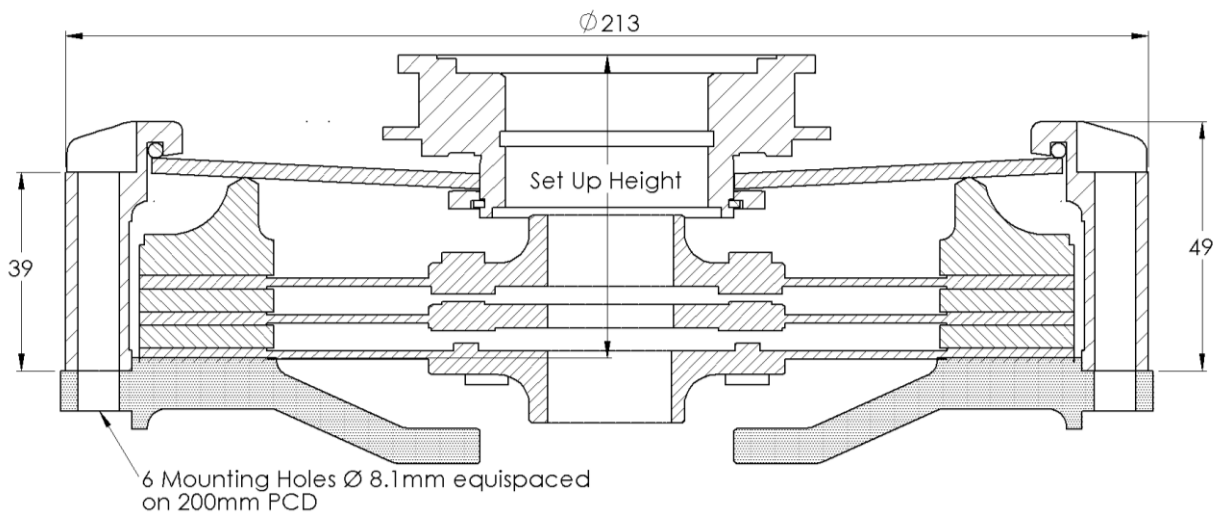

62-220

Ø184mm, Twin Cerametallic Drive Plate



Cover Torque Capacity

62-220G	463Nm	[340lb/ft]
62-220Y	652Nm	[480lb/ft]

Cover Release Load Release Bearing Travel (Max)

62-220G	250Kg	7.00mm
62-220Y	318Kg	

Set-Up Height (New)

62-220G	37.80mm
62-220Y	38.10mm

Set-Up Height (Worn)

62-220G	34.80mm
62-220Y	35.15mm

Drive Plates

	Series Part No	Thickness New [Nom]	Thickness Worn [Min]		Weight
Organic (Rigid)	55-1000	7.20 mm	6.30 mm	[See chart for spline details]	4.6 Kg
3 Paddle (Rigid)	51-1000	7.20 mm	6.30 mm	[See chart for spline details]	4.6 Kg
4 Paddle (Rigid)	52-1000	7.20 mm	6.30 mm	[See chart for spline details]	4.6 Kg
6 Paddle (Rigid)	49-1000	7.20 mm	6.30 mm	[See chart for spline details]	4.6 Kg

Other configurations available see index.

Spare Parts

Wear Clips	184-61C
Pressure Plate	184-19
Interplate	184-11
Flywheel Fixing Kit	184-1C

Applications

Organic Drive Plate Rigid Hub	Road
Paddle Rigid Hub	Race/Rally

Release Bearing: Depends on vehicle fitment – Please state when ordering.

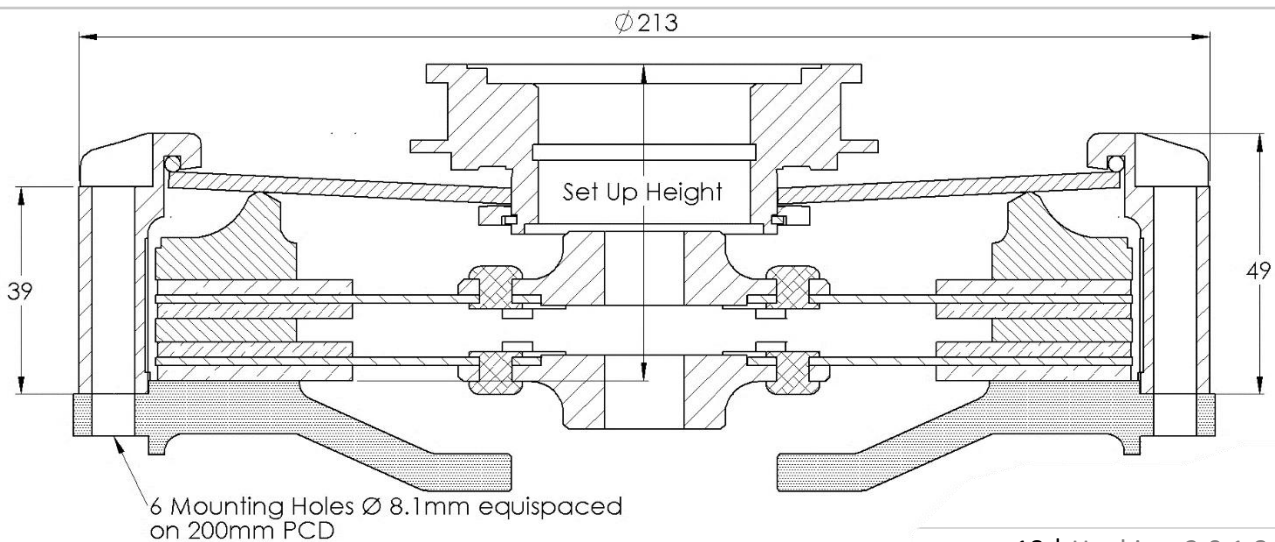

63-110
Ø184mm, Single Sintered Drive Plate



Cover	Torque Capacity	
63-110B	231Nm	[170lb/ft]
63-110R	324Nm	[238lb/ft]
63-110G	494Nm	[363lb/ft]
63-110Y	535Nm	[394lb/ft]

Cover	Release Load	Release Bearing Travel (Max)
63-110B	250Kg	6.00mm
63-110R	318Kg	
63-110G	345Kg	
63-110Y	360Kg	

Set-Up Height (New)	
63-110B	21.55mm
63-110R	21.95mm
63-110G	23.05mm
63-110Y	23.55mm

Set-Up Height (Worn)	
63-110B	25.05mm
63-110R	25.45mm
63-110G	26.55mm
63-110Y	27.00mm

Drive Plates

	Series Part No	Thickness New [Nom]	Thickness Worn [Min]		Weight
Sintered (Rigid)	53-1000	2.66 mm	1.88 mm	[See chart for spline details]	2.7 Kg
Sintered (Rigid)	53-1000A	2.66 mm	1.88 mm	[See chart for spline details]	2.7 Kg

Other configurations available see index.

Spare Parts

Wear Clips	184-61A	Flywheel Fixing Kit	184-1A
Pressure Plate	184-12		

Release Bearing: Must have curved face with a fulcrum point of between 48mm to 54mm.

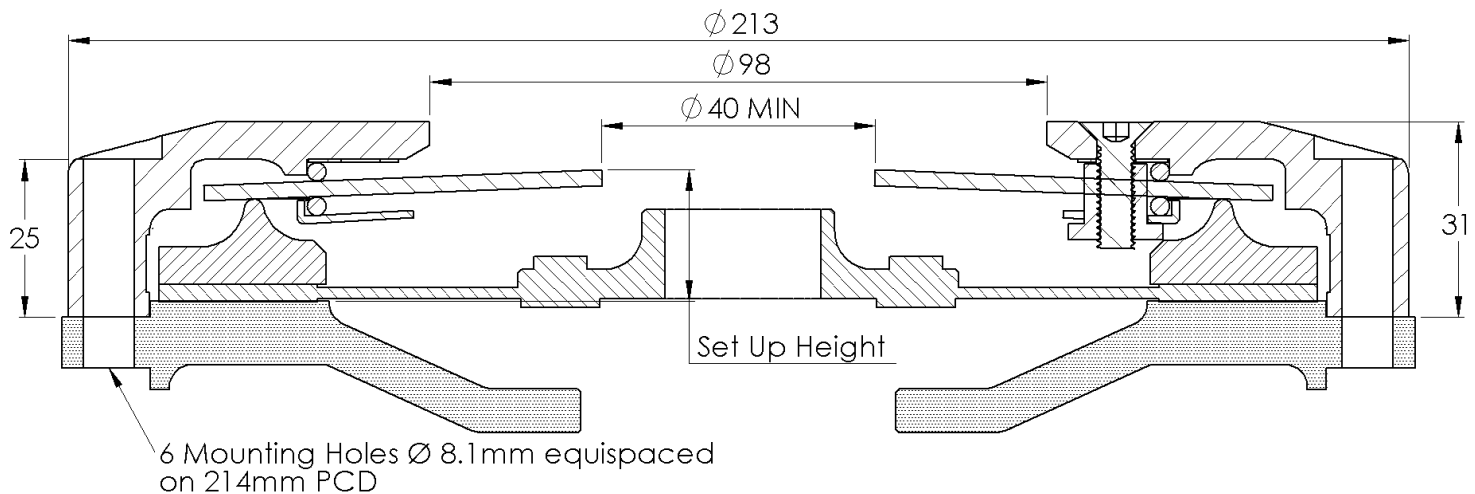

63-110c

Ø184mm, Single Sintered Drive Plate
Curly Tip Diaphragm Spring



Cover	Torque Capacity	
63-110Bc	231Nm	[170lb/ft]
63-110Rc	324Nm	[238lb/ft]
63-110Gc	494Nm	[363lb/ft]
63-110Yc	535Nm	[394lb/ft]

Cover	Release Load	Release Bearing Travel (Max)
63-110Bc	250Kg	6.00mm
63-110Rc	318Kg	
63-110Gc	345Kg	
63-110Yc	360Kg	

Set-Up Height (New)

63-110Bc	24.55mm
63-110Rc	24.95mm
63-110Gc	26.05mm
63-110Yc	26.55mm

Set-Up Height (Worn)

63-110Bc	28.05mm
63-110Rc	28.45mm
63-110Gc	29.55mm
63-110Yc	30.00mm

Drive Plates

	Series Part No	Thickness New [Nom]	Thickness Worn [Min]		Weight
Sintered (Rigid)	53-1000	2.66 mm	1.88 mm	[See chart for spline details]	2.7 Kg
Sintered (Rigid)	53-1000A	2.66 mm	1.88 mm	[See chart for spline details]	2.7 Kg

Other configurations available see index.

Spare Parts

Wear Clips	184-61A	Flywheel Fixing Kit	184-1A
Pressure Plate	184-12		

Release Bearing: Must have flat face with a fulcrum point of between 48mm to 54mm.

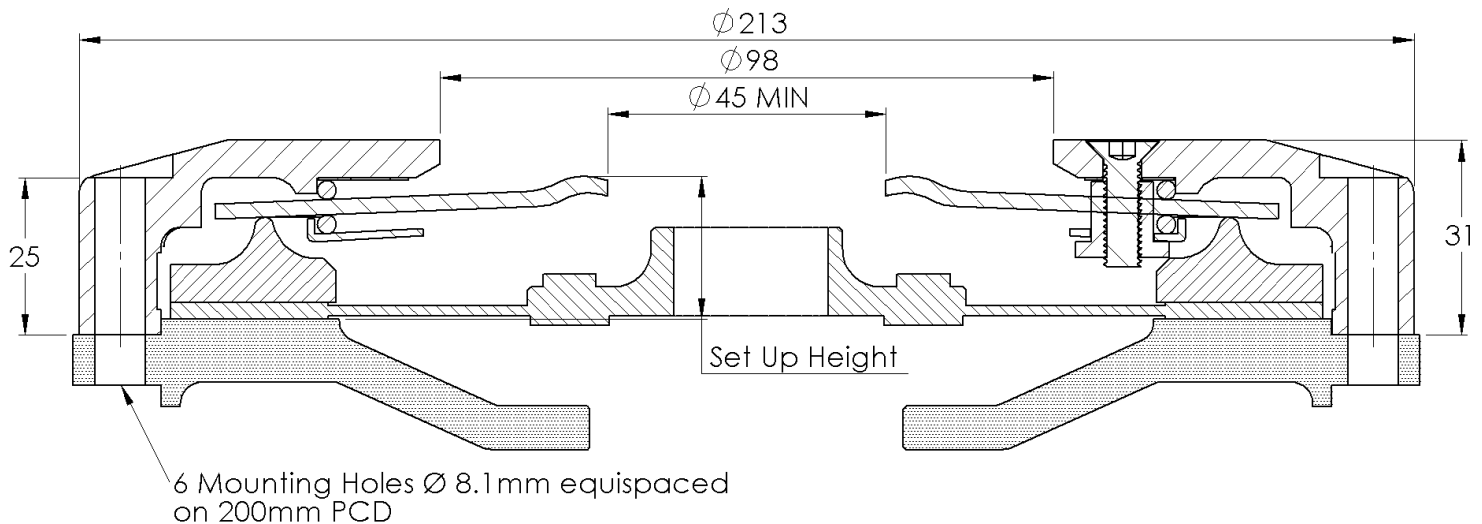

63-120
Ø184mm, Twin Sintered Drive Plate



Cover	Torque Capacity	
63-120B	469Nm	[345lb/ft]
63-120R	650Nm	[478lb/ft]
63-120G	982Nm	[722lb/ft]
63-120Y	1081Nm	[795lb/ft]

Cover	Release Load	Release Bearing Travel (Max)
63-120B	250Kg	6.00mm
63-120R	300Kg	
63-120G	345Kg	
63-120Y	360Kg	

Set-Up Height (New)	
63-120B	27.70mm
63-120R	28.70mm
63-120G	29.70mm
63-120Y	29.95mm

Set-Up Height (Worn)	
63-120B	31.60mm
63-120R	32.65mm
63-120G	33.70mm
63-120Y	34.20mm

Drive Plates

	Series Part No	Thickness New [Nom]	Thickness Worn [Min]		Weight
Sintered (Rigid)	53-1000	2.66 mm	2.22 mm	[See chart for spline details]	3.7 Kg
Sintered (Rigid)	53-1000A	2.66 mm	2.22 mm	[See chart for spline details]	3.7 Kg

Other configurations available see index.

Spare Parts

Wear Clips	184-61B	Flywheel Fixing Kit	184-1B
Pressure Plate	184-12	Interplate	184-11

Release Bearing: Must have curved face with a fulcrum point of between 48mm to 54mm.

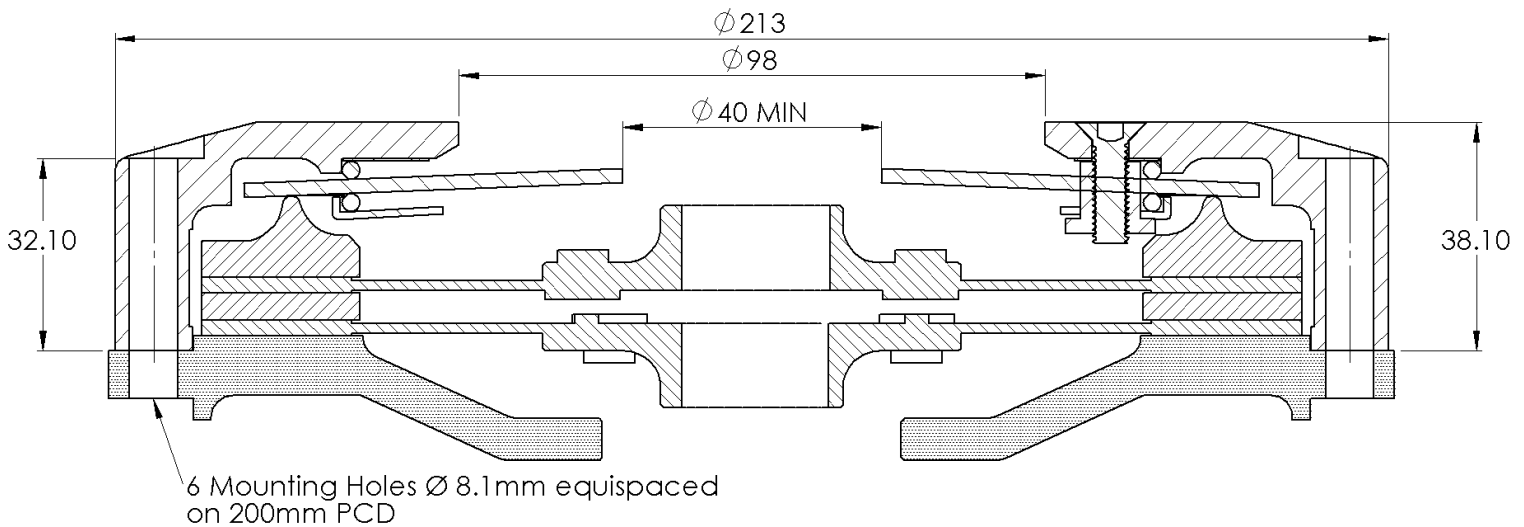

63-120c

Ø184mm, Twin Sintered Drive Plate
Curly Tip Diaphragm Spring



Cover	Torque Capacity	
63-120Bc	469Nm	[345lb/ft]
63-120Rc	650Nm	[478lb/ft]
63-120Gc	982Nm	[722lb/ft]
63-120Yc	1081Nm	[795lb/ft]

Cover	Release Load	Release Bearing Travel (Max)
63-120Bc	250Kg	6.00mm
63-120Rc	300Kg	
63-120Gc	345Kg	
63-120Yc	360Kg	

Set-Up Height (New)

63-120Bc	30.70mm
63-120Rc	31.70mm
63-120Gc	32.70mm
63-120Yc	32.95mm

Set-Up Height (Worn)

63-120Bc	34.60mm
63-120Rc	35.65mm
63-120Gc	36.70mm
63-120Yc	37.20mm

Drive Plates

	Series Part No	Thickness New [Nom]	Thickness Worn [Min]		Weight
Sintered (Rigid)	53-1000	2.66 mm	2.22 mm	[See chart for spline details]	3.7 Kg
Sintered (Rigid)	53-1000A	2.66 mm	2.22 mm	[See chart for spline details]	3.7 Kg

Other configurations available see index.

Spare Parts

Wear Clips	184-61B	Flywheel Fixing Kit	184-1B
Pressure Plate	184-12	Interplate	184-11

Release Bearing: Must have flat face with a fulcrum point of between 48mm to 54mm.

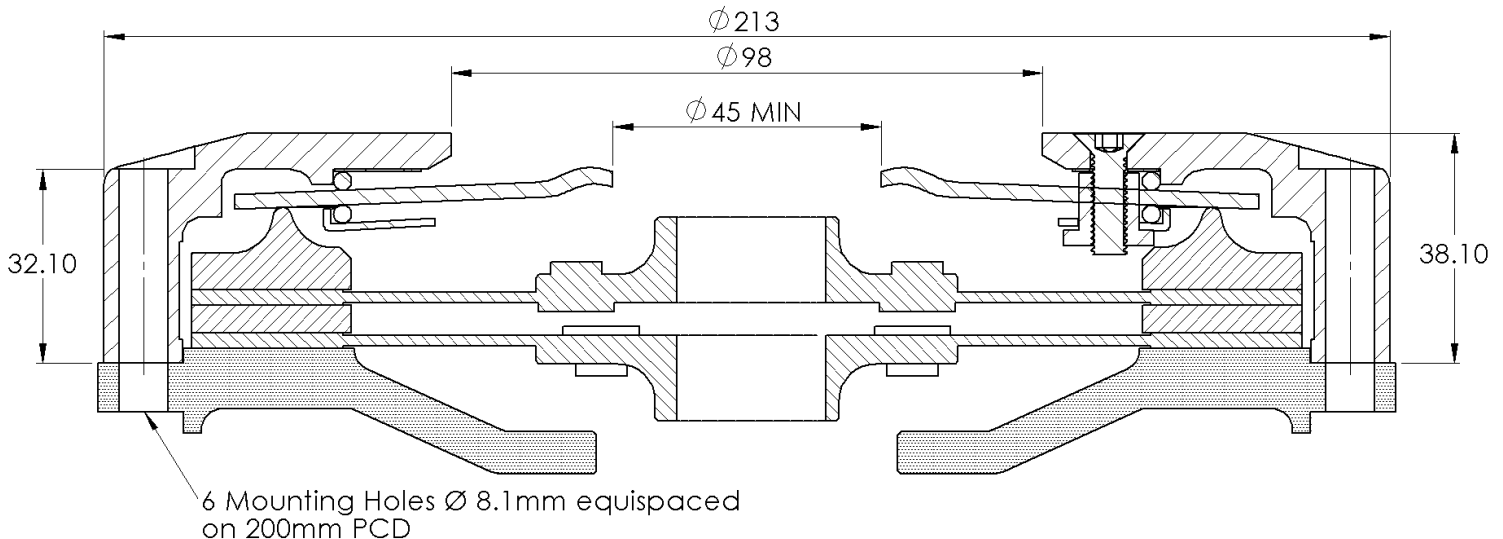

63-130
Ø184mm, Triple Sintered Drive Plate

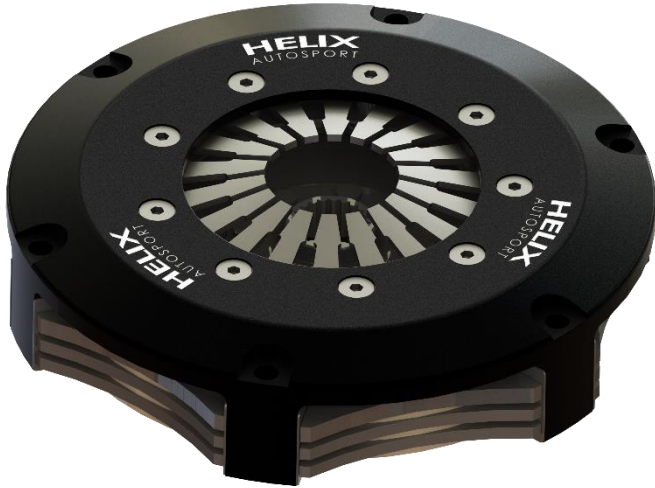

Cover	Torque Capacity	
63-130B	460Nm	[502lb/ft]
63-130R	683Nm	[712lb/ft]
63-130G	1466Nm	[1078lb/ft]
63-130Y	1612Nm	[1185lb/ft]

Cover	Release Load	Release Bearing Travel (Max)
63-130B	250Kg	6.00mm
63-130R	300Kg	
63-130G	345Kg	
63-130Y	360Kg	

Set-Up Height (New)	
63-130B	37.10mm
63-130R	38.15mm
63-130G	38.70mm
63-130Y	39.20mm

Set-Up Height (Worn)	
63-130B	41.00mm
63-130R	42.05mm
63-130G	42.65mm
63-130Y	43.20mm

Drive Plates

	Series Part No	Thickness New [Nom]	Thickness Worn [Min]		Weight
Sintered (Rigid)	53-1000	2.66 mm	2.34 mm	[See chart for spline details]	4.7 Kg
Sintered (Rigid)	54-1000	2.66 mm	2.34 mm	[See chart for spline details]	4.7 Kg
Sintered (Rigid)	53-1000A	2.66 mm	2.34 mm	[See chart for spline details]	4.7 Kg
Sintered (Rigid)	54-1000A	2.66 mm	2.34 mm	[See chart for spline details]	4.7 Kg

Other configurations available see index.

Spare Parts

Wear Clips	184-61C	Flywheel Fixing Kit	184-1C
Pressure Plate	184-14	Interplate	184-11 (x2)

Release Bearing: Must have curved face with a fulcrum point of between 48mm to 54mm.

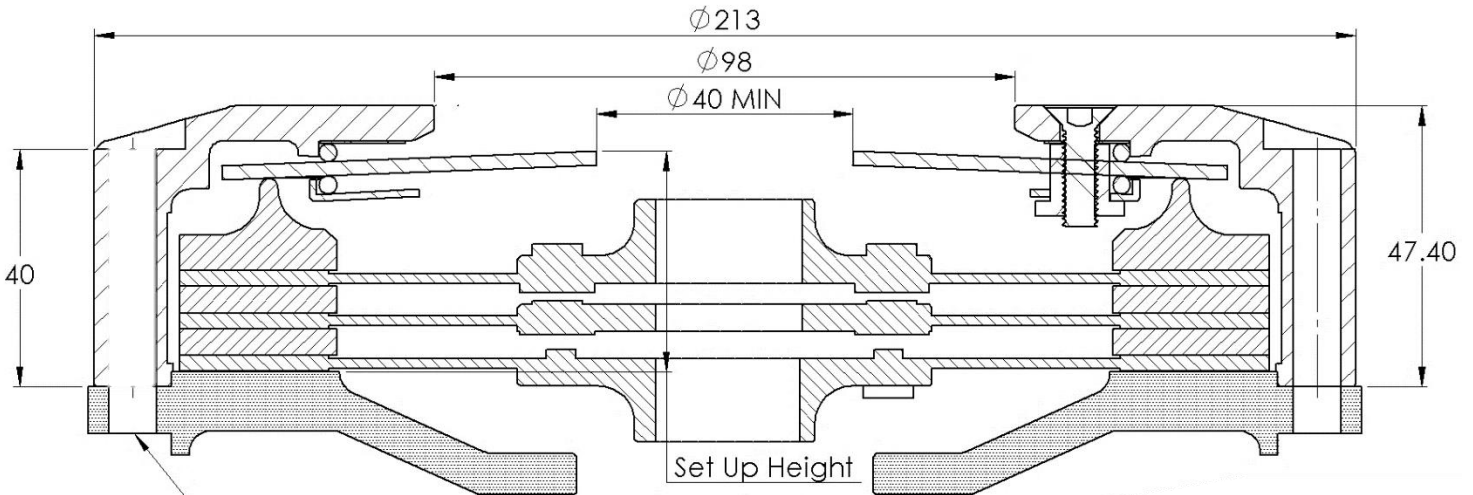

6 Mounting Holes Ø 8.1mm equispaced on 200mm PCD

63-130c

Ø184mm, Triple Sintered Drive Plate
Curly Tip Diaphragm Spring



Cover	Torque Capacity	
63-130Bc	460Nm	[502lb/ft]
63-130Rc	683Nm	[712lb/ft]
63-130Gc	1466Nm	[1078lb/ft]
63-130Yc	1612Nm	[1185lb/ft]

Cover	Release Load	Release Bearing Travel (Max)
63-130Bc	250Kg	6.00mm
63-130Rc	300Kg	
63-130Gc	345Kg	
63-130Yc	360Kg	

Set-Up Height (New)

63-130Bc	40.10mm
63-130Rc	41.15mm
63-130Gc	41.70mm
63-130Yc	42.20mm

Set-Up Height (Worn)

63-130Bc	44.00mm
63-130Rc	45.05mm
63-130Gc	45.65mm
63-130Yc	46.20mm

Drive Plates

	Series Part No	Thickness New [Nom]	Thickness Worn [Min]		Weight
Sintered (Rigid)	53-1000	2.66 mm	2.34 mm	[See chart for spline details]	4.7 Kg
Sintered (Rigid)	54-1000	2.66 mm	2.34 mm	[See chart for spline details]	4.7 Kg
Sintered (Rigid)	53-1000A	2.66 mm	2.34 mm	[See chart for spline details]	4.7 Kg
Sintered (Rigid)	54-1000A	2.66 mm	2.34 mm	[See chart for spline details]	4.7 Kg

Other configurations available see index.

Spare Parts

Wear Clips	184-61C	Flywheel Fixing Kit	184-1C
Pressure Plate	184-14	Interplate	184-11 (x2)

Release Bearing: Must have flat face with a fulcrum point of between 48mm to 54mm.

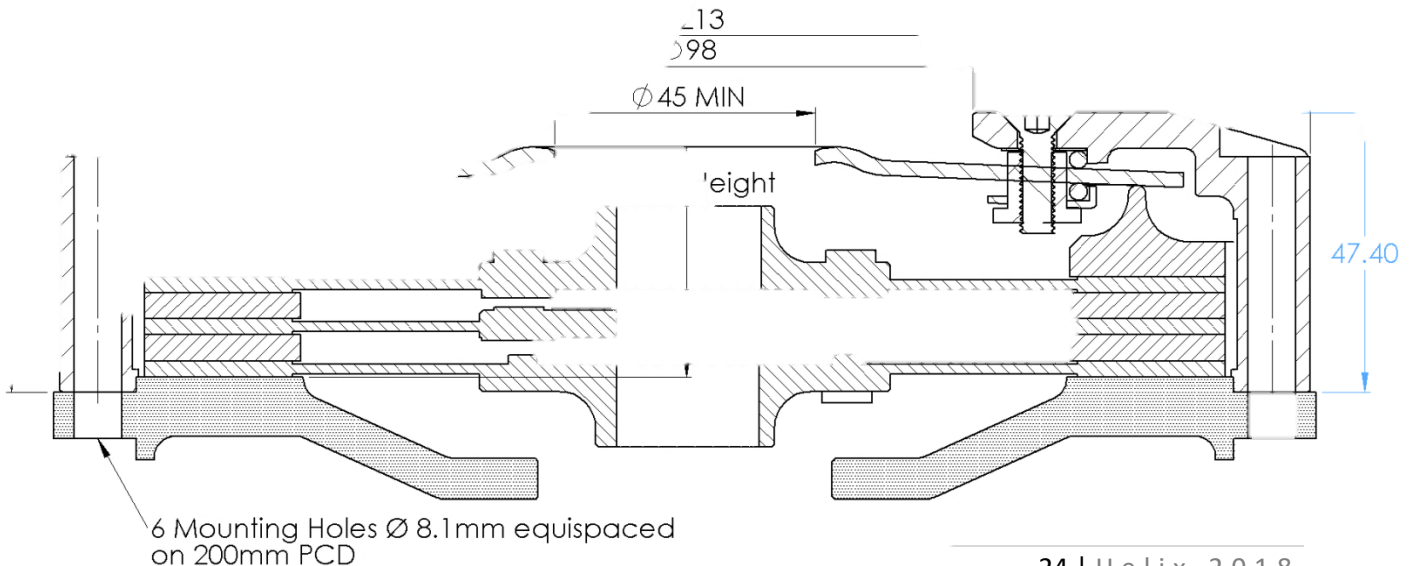

63-210

Ø184mm, Single Cerametallic Drive Plate



Cover	Torque Capacity	
63-210B	211Nm [155lb/ft]	Cerametallic Drive Plate
63-210R	299Nm [220lb/ft]	Cerametallic Drive Plate
63-210G	445Nm [327lb/ft]	Cerametallic Drive Plate
63-210Y	490Nm [360lb/ft]	Cerametallic Drive Plate
63-210B	152Nm [112lb/ft]	Organic Drive Plate
63-210R	216Nm [159lb/ft]	Organic Drive Plate
63-210G	324Nm [238lb/ft]	Organic Drive Plate
63-210Y	356Nm [262lb/ft]	Organic Drive Plate

Cover	Release Load	Release Bearing Travel (Max)
63-210B	250Kg	6.00mm
63-210R	300Kg	
63-210G	345Kg	
63-210Y	360Kg	

Set-Up Height (New)

63-210B	28.80mm
63-210R	30.40mm
63-210G	31.50mm
63-210Y	31.80mm

Set-Up Height (Worn)

63-210B	32.70mm
63-210R	33.55mm
63-210G	35.35mm
63-210Y	35.70mm

Drive Plates

	Series Part No	Thickness New [Nom]	Thickness Worn [Min]		Weight
Organic (Rigid)	55-1000	7.20 mm	6.30 mm	[See chart for spline details]	2.7 Kg
3 Paddle (Rigid)	51-1000	7.20 mm	6.30 mm	[See chart for spline details]	2.8 Kg
4 Paddle (Rigid)	52-1000	7.20 mm	6.30 mm	[See chart for spline details]	2.9 Kg
6 Paddle (Rigid)	49-1000	7.20 mm	6.30 mm	[See chart for spline details]	3.0 Kg

Other configurations available see index.

Spare Parts

Wear Clips	184-61B
Pressure Plate	184-15
Flywheel Fixing Kit	184-1B

Applications

Organic Drive Plate Rigid Hub	Road
Paddle Rigid Hub	Race/Rally

Release Bearing: Must have curved face with a fulcrum point of between 48mm to 54mm.

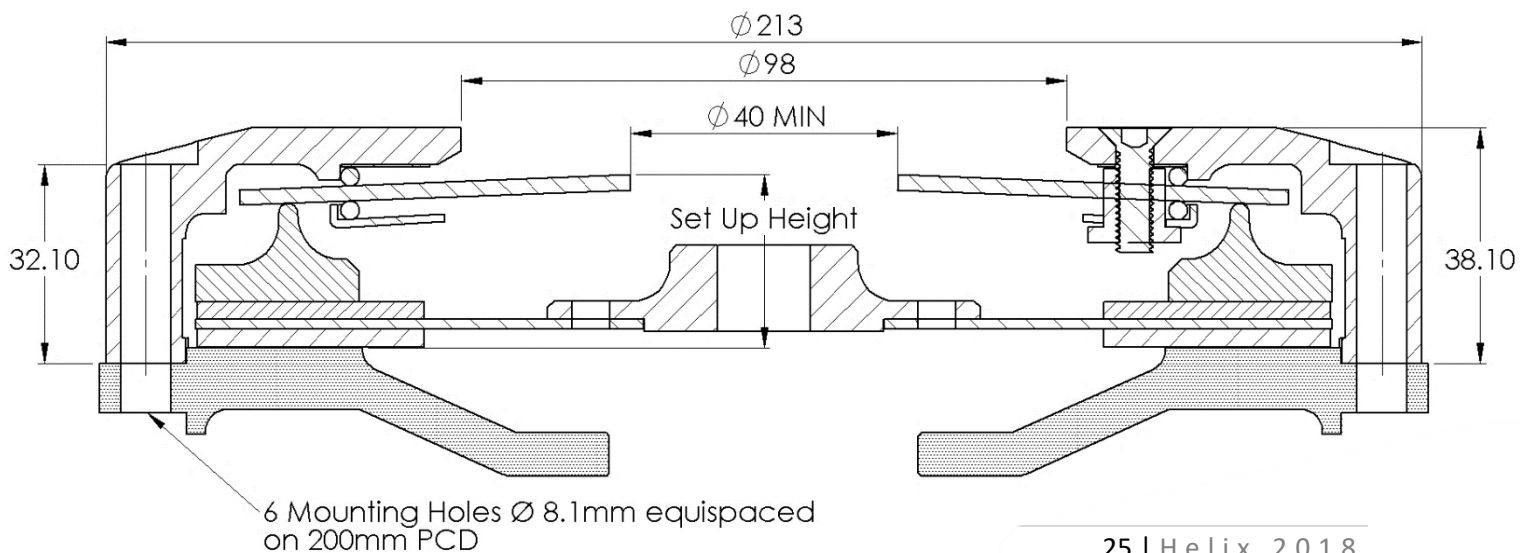

63-210c

Ø184mm, Single Cerametallic Drive Plate
Curly Tip Diaphragm Spring



Cover	Torque Capacity	
63-210Bc	211Nm [155lb/ft]	Cerametallic Drive Plate
63-210Rc	299Nm [220lb/ft]	Cerametallic Drive Plate
63-210Gc	445Nm [327lb/ft]	Cerametallic Drive Plate
63-210Yc	490Nm [360lb/ft]	Cerametallic Drive Plate
63-210Bc	152Nm [112lb/ft]	Organic Drive Plate
63-210Rc	216Nm [159lb/ft]	Organic Drive Plate
63-210Gc	324Nm [238lb/ft]	Organic Drive Plate
63-210Yc	356Nm [262lb/ft]	Organic Drive Plate

Cover	Release Load	Release Bearing Travel (Max)
63-210Bc	250Kg	6.00mm
63-210Rc	300Kg	
63-210Gc	345Kg	
63-210Yc	360Kg	

Set-Up Height (New)

63-210Bc	31.80mm
63-210Rc	33.40mm
63-210Gc	34.50mm
63-210Yc	34.80mm

Set-Up Height (Worn)

63-210Bc	35.70mm
63-210Rc	36.55mm
63-210Gc	38.35mm
63-210Yc	38.70mm

Drive Plates

	Series Part No	Thickness New [Nom]	Thickness Worn [Min]		Weight
Organic (Rigid)	55-1000	7.20 mm	6.30 mm	[See chart for spline details]	2.7 Kg
3 Paddle (Rigid)	51-1000	7.20 mm	6.30 mm	[See chart for spline details]	2.8 Kg
4 Paddle (Rigid)	52-1000	7.20 mm	6.30 mm	[See chart for spline details]	2.9 Kg
6 Paddle (Rigid)	49-1000	7.20 mm	6.30 mm	[See chart for spline details]	3.0 Kg

Other configurations available see index.

Spare Parts

Wear Clips	184-61B
Pressure Plate	184-15
Flywheel Fixing Kit	184-1B

Applications

Organic Drive Plate Rigid Hub	Road
Paddle Rigid Hub	Race/Rally

Release Bearing: Must have flat face with a fulcrum point of between 48mm to 54mm.

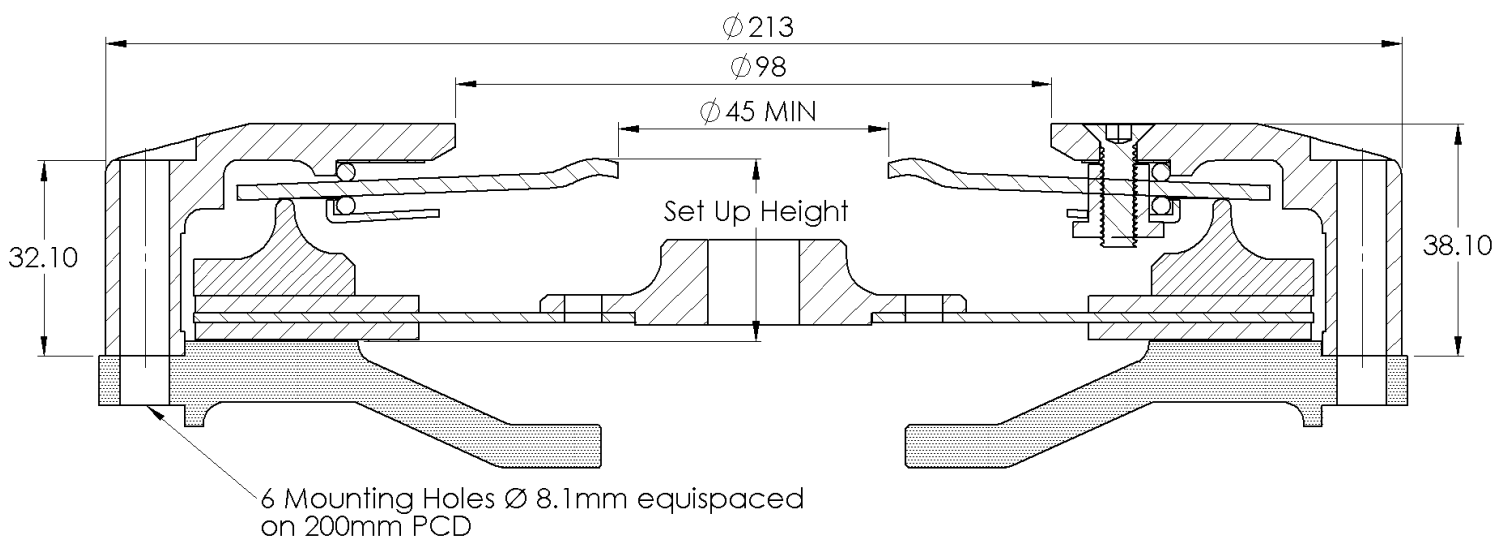

63-220

Ø184mm, Twin Cerametallic Drive Plate



Cover	Torque Capacity	
63-220B	291Nm [214lb/ft]	Cerametallic Drive Plate
63-220R	422Nm [310lb/ft]	Cerametallic Drive Plate
63-220G	626Nm [460lb/ft]	Cerametallic Drive Plate
63-220Y	688Nm [506lb/ft]	Cerametallic Drive Plate
63-220B	215Nm [158lb/ft]	Organic Drive Plate
63-220R	305Nm [224lb/ft]	Organic Drive Plate
63-220G	453Nm [333lb/ft]	Organic Drive Plate
63-220Y	498Nm [366lb/ft]	Organic Drive Plate

Cover	Release Load	Release Bearing Travel (Max)
63-220B	255Kg	6.00mm
63-220R	300Kg	
63-220G	345Kg	
63-220Y	360Kg	

Set-Up Height (New)

63-220B	37.55mm
63-220R	38.40mm
63-220G	39.30mm
63-220Y	39.55mm

Set-Up Height (Worn)

63-220B	41.45mm
63-220R	42.50mm
63-220G	43.80mm
63-220Y	44.10mm

Drive Plates

	Series Part No	Thickness New [Nom]	Thickness Worn [Min]		Weight
Organic (Rigid)	55-1000	7.20 mm	6.30 mm	[See chart for spline details]	3.8 Kg
3 Paddle (Rigid)	51-1000	7.20 mm	6.30 mm	[See chart for spline details]	3.9 Kg
4 Paddle (Rigid)	52-1000	7.20 mm	6.30 mm	[See chart for spline details]	4.1 Kg
6 Paddle (Rigid)	49-1000	7.20 mm	6.30 mm	[See chart for spline details]	4.5 Kg

Other configurations available see index.

Spare Parts

Wear Clips	184-61C
Pressure Plate	184-12
Flywheel Fixing Kit	184-1C
Interplate	184-11

Applications

Organic Drive Plate Rigid Hub	Road
Paddle Rigid Hub	Race/Rally

Release Bearing: Must have curved face with a fulcrum point of between 48mm to 54mm.

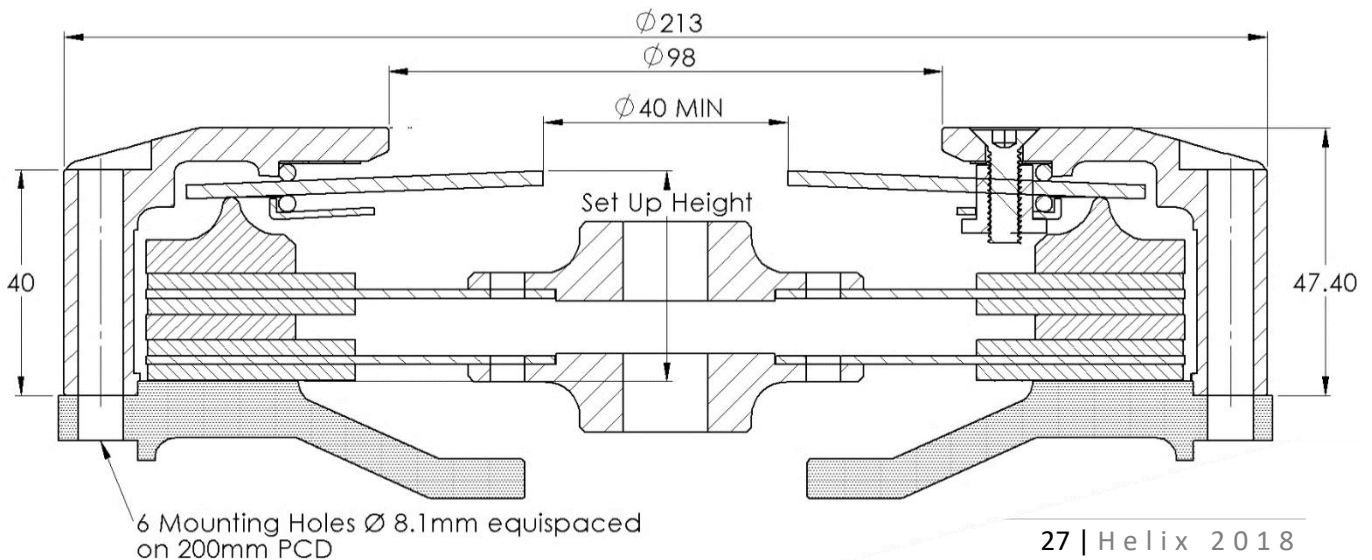

63-220c

Ø184mm, Twin Cerametallic Drive Plate
Curly Tip Diaphragm Spring

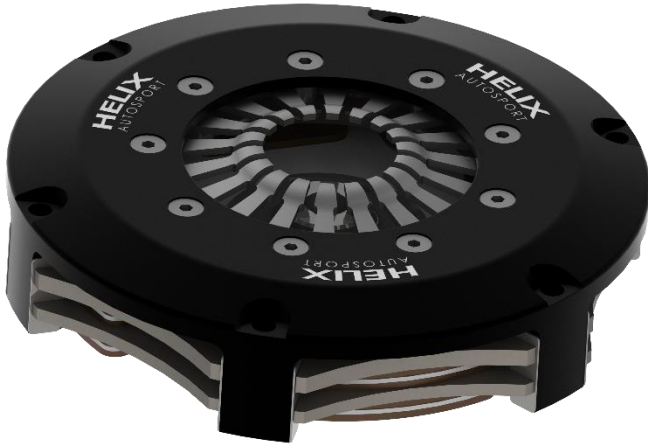

Cover	Torque Capacity	
63-220Bc	291Nm [214lb/ft]	Cerametallic Drive Plate
63-220Rc	422Nm [310lb/ft]	Cerametallic Drive Plate
63-220Gc	626Nm [460lb/ft]	Cerametallic Drive Plate
63-220Yc	688Nm [506lb/ft]	Cerametallic Drive Plate
63-220Bc	215Nm [158lb/ft]	Organic Drive Plate
63-220Rc	305Nm [224lb/ft]	Organic Drive Plate
63-220Gc	453Nm [333lb/ft]	Organic Drive Plate
63-220Yc	498Nm [366lb/ft]	Organic Drive Plate

Cover	Release Load	Release Bearing Travel (Max)
63-220Bc	255Kg	6.00mm
63-220Rc	300Kg	
63-220Gc	345Kg	
63-220Yc	360Kg	

Set-Up Height (New)

63-220Bc	40.55mm
63-220Rc	41.40mm
63-220Gc	42.30mm
63-220Yc	42.55mm

Set-Up Height (Worn)

63-220Bc	44.45mm
63-220Rc	45.50mm
63-220Gc	46.80mm
63-220Yc	47.10mm

Drive Plates

	Series Part No	Thickness New [Nom]	Thickness Worn [Min]		Weight
Organic (Rigid)	55-1000	7.20 mm	6.30 mm	[See chart for spline details]	3.8 Kg
3 Paddle (Rigid)	51-1000	7.20 mm	6.30 mm	[See chart for spline details]	3.9 Kg
4 Paddle (Rigid)	52-1000	7.20 mm	6.30 mm	[See chart for spline details]	4.1 Kg
6 Paddle (Rigid)	49-1000	7.20 mm	6.30 mm	[See chart for spline details]	4.5 Kg

Other configurations available see index.

Spare Parts

Wear Clips	184-61C
Pressure Plate	184-12
Flywheel Fixing Kit	184-1C
Interplate	184-11

Applications

Organic Drive Plate Rigid Hub	Road
Paddle Rigid Hub	Race/Rally

Release Bearing: Must have flat face with a fulcrum point of between 48mm to 54mm.

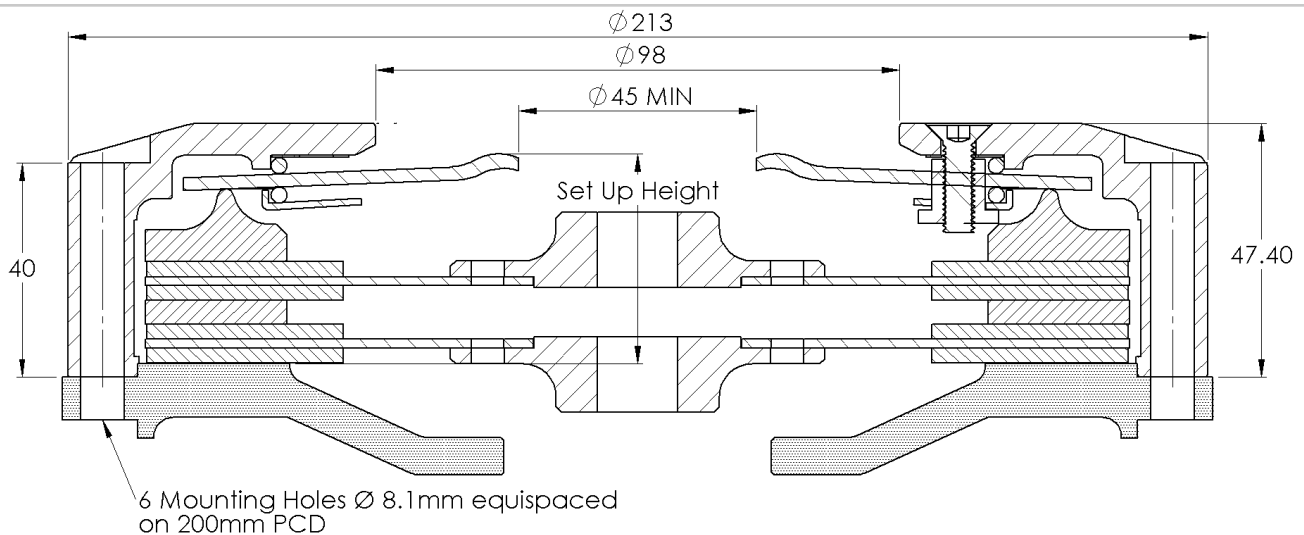

63-230

Ø184mm, Triple Cerametallic Drive Plate



Cover	Torque Capacity	
63-230R	780Nm [573lb/ft]	Cerametallic Drive Plate
63-230G	1250Nm[919lb/ft]	Cerametallic Drive Plate
63-230Y	1496Nm[1100lb/ft]	Cerametallic Drive Plate
63-230R	560Nm [411lb/ft]	Organic Drive Plate
63-230G	685Nm [504lb/ft]	Organic Drive Plate
63-230Y	898Nm [660lb/ft]	Organic Drive Plate

Cover	Release Load	Release Bearing Travel (Max)
63-230R	300Kg	6.00mm
63-230G	345Kg	
63-230Y	360Kg	

Set-Up Height (New)

63-230R	44.00mm
63-230G	44.70mm
63-230Y	44.90mm

Set-Up Height (Worn)

63-230R	48.10mm
63-230G	49.00mm
63-230Y	49.00mm

Drive Plates

	Series Part No	Thickness New [Nom]	Thickness Worn [Min]		Weight
Organic (Rigid)	55-1000	7.20 mm	6.30 mm	[See chart for spline details]	3.8 Kg
3 Paddle (Rigid)	51-1000	7.20 mm	6.30 mm	[See chart for spline details]	3.9 Kg
4 Paddle (Rigid)	52-1000	7.20 mm	6.30 mm	[See chart for spline details]	4.1 Kg
6 Paddle (Rigid)	49-1000	7.20 mm	6.30 mm	[See chart for spline details]	4.5 Kg

Other configurations available see index.

Spare Parts

Wear Clips	184-61D
Pressure Plate	184-19
Flywheel Fixing Kit	184-1D
Interplate	184-11

Applications

Organic Drive Plate Rigid Hub	Road
Paddle Rigid Hub	Race/Rally

Release Bearing: Must have curved face with a fulcrum point of between 48mm to 54mm.

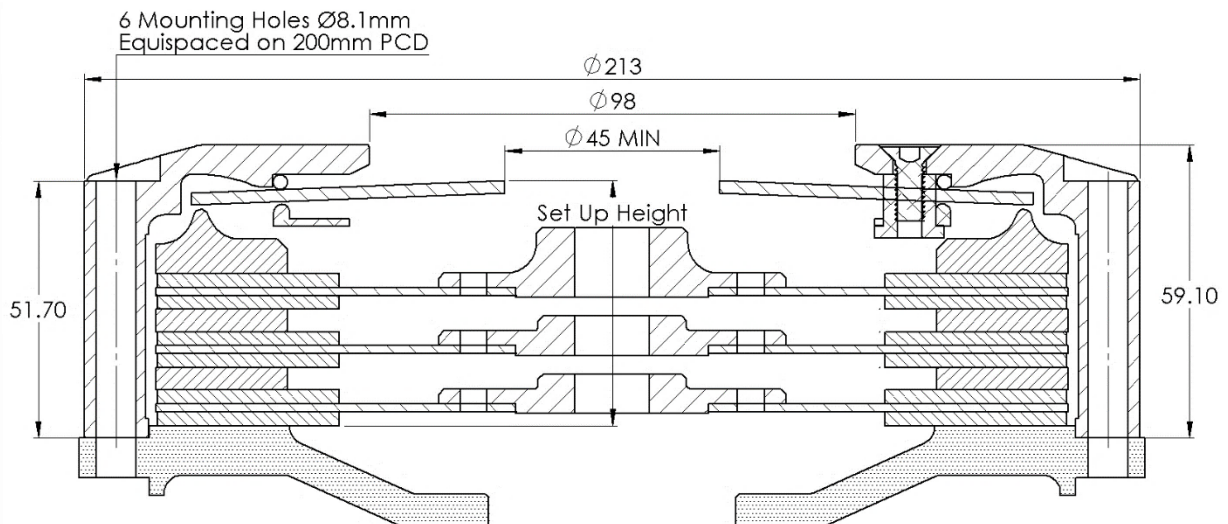

63-230c

Ø184mm, Triple Cerametallic Drive Plate
Curly Tip Diaphragm Spring



Cover	Torque Capacity	
63-230Rc	780Nm [573lb/ft]	Cerametallic Drive Plate
63-230Gc	1250Nm[919lb/ft]	Cerametallic Drive Plate
63-230Yc	1496Nm[1100lb/ft]	Cerametallic Drive Plate
63-230Rc	560Nm [411lb/ft]	Organic Drive Plate
63-230Gc	685Nm [504lb/ft]	Organic Drive Plate
63-230Yc	898Nm [660lb/ft]	Organic Drive Plate

Cover	Release Load	Release Bearing Travel (Max)
63-230Rc	300Kg	6.00mm
63-230Gc	345Kg	
63-230Yc	360Kg	

Set-Up Height (New)

63-230Rc	47.00mm
63-230Gc	47.90mm
63-230Yc	48.00mm

Set-Up Height (Worn)

63-230Rc	52.00mm
63-230Gc	52.90mm
63-230Yc	53.10mm

Drive Plates

	Series Part No	Thickness New [Nom]	Thickness Worn [Min]		Weight
Organic (Rigid)	55-1000	7.20 mm	6.30 mm	[See chart for spline details]	3.8 Kg
3 Paddle (Rigid)	51-1000	7.20 mm	6.30 mm	[See chart for spline details]	3.9 Kg
4 Paddle (Rigid)	52-1000	7.20 mm	6.30 mm	[See chart for spline details]	4.1 Kg
6 Paddle (Rigid)	49-1000	7.20 mm	6.30 mm	[See chart for spline details]	4.5 Kg

Other configurations available see index.

Spare Parts

Wear Clips	184-61D
Pressure Plate	184-19
Flywheel Fixing Kit	184-1C
Interplate	184-11

Applications

Organic Drive Plate Rigid Hub	Road
Paddle Rigid Hub	Race/Rally

Release Bearing: Must have curved face with a fulcrum point of between 48mm to 54mm.

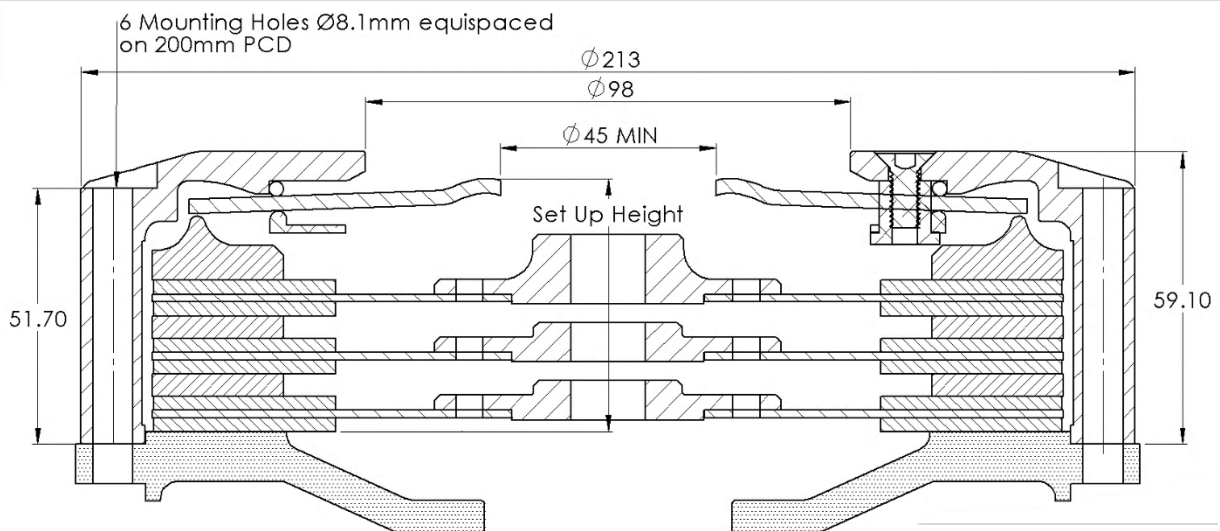

63-230 Short

Ø184mm, Triple Organic Drive Plate
For those wanting grater torque capacity in a smaller form



Cover	Torque Capacity	
63-230SB	456Nm [336lb/ft]	Organic Drive Plate
63-230SR	560Nm [411lb/ft]	Organic Drive Plate
63-230SG	685Nm [504lb/ft]	Organic Drive Plate
63-230SY	898Nm [660lb/ft]	Organic Drive Plate

Cover	Release Load	Release Bearing Travel (Max)
63-230SB	255Kg	6.00mm
63-230SR	300Kg	
63-230SG	345Kg	
63-230SY	360Kg	

Set-Up Height (New)

63-230SR	46.50mm
63-230SG	46.30mm
63-230SY	46.10mm
63-230SRc	49.50mm
63-230SGc	49.30mm
63-230SYc	49.10mm

Set-Up Height (Worn)

63-230SR	50.50mm
63-230SG	49.80mm
63-230SY	49.10mm
63-230SRc	53.50mm
63-230SGc	52.80mm
63-230SYc	52.10mm

Drive Plates

	Series Part No	Thickness New [Nom]	Thickness Worn [Min]	Weight
Organic (Rigid)	55-2000	5.50 mm	4.90 mm	[See chart for spline details] 2.6 Kg

Other configurations available see index.

Spare Parts

Wear Clips	184-61D
Pressure Plate	184-19
Flywheel Fixing Kit	184-1C
Interplate	184-11

Applications

Organic Drive Plate Rigid Hub Road

Release Bearing: Must have curved face with a fulcrum point of between 48mm to 54mm.

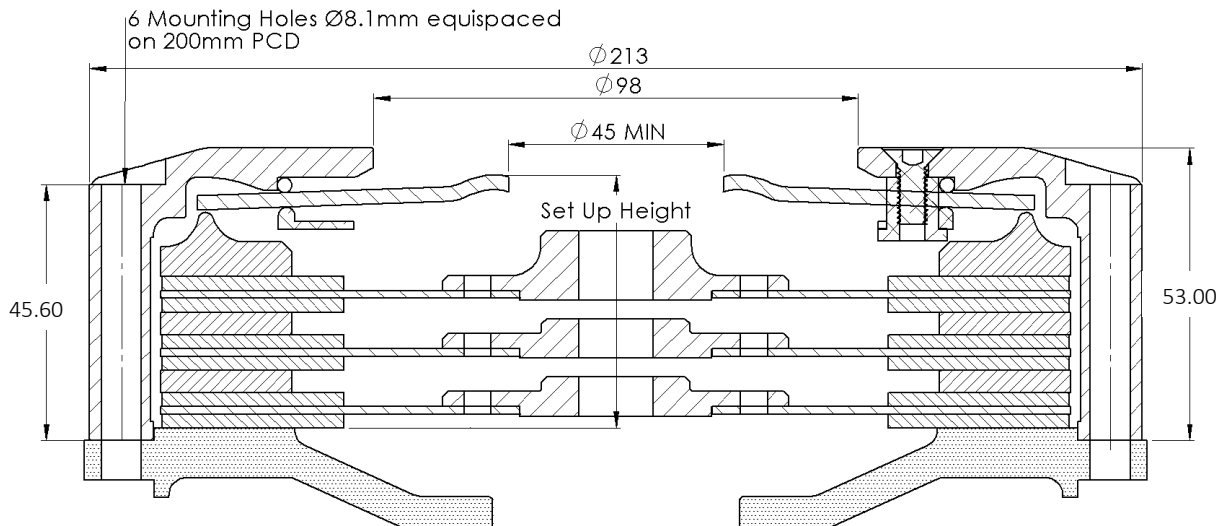

184mm Ø Sintered, Cerametallic & Organic Drive Plate Hub Spline Details

Spline Data	3 Paddle Cerametallic Rigid Hub	4 Paddle Cerametallic Rigid Hub	6 Paddle Cerametallic Rigid Hub	Sintered Outer	Sintered Inner	Organic Rigid	Organic Sprung Hub	3 Paddle Cerametallic Sprung Hub	4 Paddle Cerametallic Sprung Hub	Application
25.4mm x 23T	51-1001	52-1001	49-1001	53-1001	54-1001	55-1001	57-1001	56-1001	56-2001	Ford ,Mitsubishi,MG & Porsche
22.5mm x 20T	51-1002	52-1002	49-1002	53-1002	54-1002	55-1002	57-1002	56-1002	56-2002	Ford ,Fiat,Mitsubishi & Porsche
24.3mm x 22T	51-1003	52-1003	49-1003	53-1003	54-1003	55-1003	57-1003	56-1003	56-2003	Mazda
29mm x 21T	51-1004	52-1004	49-1004	53-1004	54-1004	55-1004				Toyota
25.6mm x 24T	51-1005	52-1005	49-1005	53-1005	54-1005	55-1005	57-1005	56-1005	56-2005	Nissan
24mm x 21T	51-1006	52-1006	49-1006	53-1006	54-1006	55-1006	57-1006	56-1006	56-2006	Renault
24mm x 21T	51-1007	52-1007	49-1007	53-1007	54-1007	55-1007	57-1007	56-1007	56-2007	Toyota
25mm x 14T	51-1008	52-1008	49-1008	53-1008	54-1008	55-1008	57-1008	56-1008	56-2008	BMW,Mini,Opel & Vauxhall
29mm x 10T	51-1009	52-1009	49-1009	53-1009	54-1009	55-1009				BMW, Ford & Mercedes
21mm x 18T	51-1010	52-1010	49-1010	53-1010	54-1010	55-1010	57-1010	56-1010	56-2010	Peugeot
20mm x 17T	51-1011	52-1011	49-1011	53-1011	54-1011	55-1011	57-1011	56-1011	56-2011	Ford & Fiat
20.4mm x 24T	51-1012	52-1012	49-1012	53-1012	54-1012	55-1012	57-1012	56-1012	56-2012	Opel,Vauxhall & Volkswagen
22mm x 19T	51-1013	52-1013	49-1013	53-1013	54-1013	55-1013	57-1013	56-1013	56-2013	Alfa Romeo
1 1/4" x 10T	51-1014	52-1014	49-1014	53-1014	54-1014	55-1014				Aston Martin,Ferrari & Triumph
24.2 x 23T	51-1015	52-1015	49-1015	53-1015	54-1015	55-1015	57-1015	56-1015	56-2015	Audi & Volkswagen
1 1/8" x 10T	51-1016	52-1016	49-1016	53-1016	54-1016	55-1016				Jaguar,(GM(USA) & Rover
22.1mm x 28T	51-1017	52-1017	49-1017	53-1017	54-1017	55-1017	57-1017	56-1017	56-2017	Audi & Volkswagen
29mm x 10T	51-1018	52-1018	49-1018	53-1018	54-1018	55-1018				Peugeot & Renault
19.3mm x 18T	51-1019	52-1019	49-1019	53-1019	54-1019	55-1019	57-1019	56-1019	56-2019	Suzuki
22mm x 26T	51-1020	52-1020	49-1020	53-1020	54-1020	55-1020	57-1020	56-1020	56-2020	Renault
19mm x 14T	51-1021	52-1021	49-1021	53-1021	54-1021	55-1021	57-1021	56-1021	56-2021	Opel & Vauxhall
22mm x 20T	51-1022	52-1022	49-1022	53-1022	54-1022	55-1022	57-1022	56-1022	56-2022	Honda & Rover
7/8" x 10T	51-1023	52-1023	49-1023	53-1023	54-1023	55-1023	57-1023	56-1023	56-2023	Austin Healey,Hillman,MG & Rover
25.4mm x 24T	51-1024	52-1024	49-1024	53-1024	54-1024	55-1024	57-1024	56-1024	56-2024	Honda & Rover
25.9mm x 24T	51-1025	52-1025	49-1025	53-1025	54-1025	55-1025	57-1025	56-1025	56-2025	Honda
1 1/16" x 10T	51-1026	52-1026	49-1026	53-1026	54-1026	55-1026				Ford (USA)
1 5/32" x 26T	51-1027	52-1027	49-1027	53-1027	54-1027	55-1027				GM (USA)
20mm x 18T	51-1028	52-1028	49-1028	53-1028	54-1028	55-1028	57-1028	56-1028	56-2028	Nissan & Skoda
28.7mm x 26T	51-1029	52-1029	49-1029	53-1029	54-1029	55-1029				Mercedes
1" x 10T	51-1030	52-1030	49-1030	53-1030	54-1030	55-1030	57-1030	56-1030	56-2030	Alfa Romeo, Talbot & Triumph.
25.2mm x 24T	51-1031	52-1031	49-1031	53-1031	54-1031	55-1031	57-1031	56-1031	56-2031	Subaru
25mm x 22T	51-1032	52-1032	49-1032	53-1032	54-1032	55-1032	57-1032	56-1032	56-2032	Volvo
21.8mm x 20T	51-1033	52-1033	49-1033	53-1033	54-1033	55-1033	57-1033	56-1033	56-2033	Volvo
35mm x 10T	51-1035	52-1035	49-1035	53-1035	54-1035					BMW
28mm x 25T	51-1038	52-1038	49-1038	53-1038	54-1038	55-1038				Lotus & Vauxhall

184mm Ø Sintered, Cerametallic & Organic Drive Plate Hub Spline Details.

Spline Data	3 Paddle	4 Paddle	6 Paddle	Sintered Outer	Sintered Inner	Organic Rigid	Organic Sprung Hub	3 Paddle Cerametallic Sprung Hub	4 Paddle Cerametallic Sprung Hub	Application
28mm x 20T	51-1039	52-1039	49-1039	53-1039	54-1039	55-1040	57-1040	56-1040	56-2040	Toyota
22.5mm x 19T	51-1040	52-1040	49-1040	53-1040	54-1040	55-1040	57-1040	56-1040	56-2040	Toyota
1 3/8" x 10T	51-1041	52-1041	49-1041	53-1041	54-1041	55-1041	57-1041	56-1041	56-2041	Ferrari
19mm x 17T	51-1042	52-1042	49-1042	53-1042	54-1042	55-1042	57-1042	56-1042	56-2042	SAAB
25.4mm x 23T	51-1043	52-1043	49-1043	53-1043	54-1043	55-1043	57-1043	56-1043	56-2043	Sadev Gearbox spline
29mm x 22T	51-1044	52-1044	49-1044	53-1044	54-1044	55-1044	57-1044	56-1044	56-2044	BMW
28mm x 25T	51-1045	52-1045	49-1045	53-1045	54-1045	55-1045	57-1045	56-1045	56-2045	Ferrari
20mm x 19T	51-1046	52-1046	49-1046	53-1046	54-1046	55-1046	57-1046	56-1046	56-2046	Honda
17.3mm x 20T	51-1047	52-1047	49-1047	53-1047	54-1047	55-1047	57-1047	56-1047	56-2047	Fiat, Renault
35mm x 26T	51-1048	52-1048	49-1048	53-1048	54-1048	55-1048	57-1048	56-1048	56-2048	BMW
24.5mm x 21T	51-1049	52-1049	49-1049	53-1049	54-1049	55-1049	57-1049	56-1049	56-2049	Renault
29mm x 26T	51-1050	52-1050	49-1050	53-1050	54-1050	55-1050	57-1050	56-1050	56-2050	Audi & Volkswagen
1" x 6T	51-1051	52-1051	49-1051	53-1051	54-1051	55-1051	57-1051	56-1051	56-2051	Ferrari
24.3 x 21T	51-1052	52-1052	49-1052	53-1052	54-1052	55-1052	57-1052	56-1052	56-2052	Lotus
7/8" x 6T	51-1053	52-1053	49-1053	53-1053	54-1053	55-1053	57-1053	56-1053	56-2053	Alfa Romeo
25mm x 6T	51-1054	52-1054	49-1054	53-1054	54-1054	55-1054	57-1054	56-1054	56-2054	O.M 1929
34mm x 6T	51-1055	52-1055	49-1055	53-1055	54-1055	55-1055	57-1055	56-1055	56-2055	Lancia
38mm x 10T	51-1056	52-1056	49-1056	53-1056	54-1056	55-1056	57-1056	56-1056	56-2056	Ferrari Flywheel HF 9476
33mm x 30T	51-1057	52-1057	49-1057	53-1057	54-1057	55-1057	57-1057	56-1057	56-2057	Lancia Astura
27.2mm x 10T	51-1058	52-1058	49-1058	53-1058	54-1058	55-1058	57-1058	56-1058	56-2058	

184mm Ø Sintered, Cerametallic & Organic Drive Plate Hub Spline Details

Spline Data	Geared		Geared		Geared		Application
	Hub Plate Sintered	Hub Plate Cerametallic 4 Paddle	Hub Plate Cerametallic 6 Paddle	Hub Plate Organic	Hub Plate Organic	Hub Plate Organic	
25.4mm x 23T	48-2001	48-1001	48-1101	48-3001	48-3001	48-3001	Ford,Mitsubishi,MG & Porsche
22.5mm x 20T	48-2002	48-1002	48-1102	48-3002	48-3002	48-3002	Ford, Fiat,Mitsubishi & Porsche
24.3mm x 22T	48-2003	48-1003	48-1103	48-3003	48-3003	48-3003	Mazda
29mm x 21T	48-2004	48-1004	48-1104	48-3004	48-3004	48-3004	Toyota
25.6mm x 24T	48-2005	48-1005	48-1105	48-3005	48-3005	48-3005	Nissan
24mm x 21T	48-2006	48-1006	48-1106	48-3006	48-3006	48-3006	Renault
24mm x 21T	48-2007	48-1007	48-1107	48-3007	48-3007	48-3007	Toyota
25mm x 14T	48-2008	48-1008	48-1108	48-3008	48-3008	48-3008	BMW Mini,Opel & Vauxhall
29mm x 10T	48-2009	48-1009	48-1109	48-3009	48-3009	48-3009	BMW, Ford & Mercedes
21mm x 18T	48-2010	48-1010	48-1110	48-3010	48-3010	48-3010	Peugeot
20mm x 17T	48-2011	48-1011	48-1111	48-3011	48-3011	48-3011	Ford & Fiat
20.4mm x 24T	48-2012	48-1012	48-1112	48-3012	48-3012	48-3012	Opel,Vauxhall & Volkswagen
22mm x 19T	48-2013	48-1013	48-1113	48-3013	48-3013	48-3013	Alfa Romeo
1 1/4" x 10T	48-2014	48-1014	48-1114	48-3014	48-3014	48-3014	Aston Martin,Ferrari & Triumph
24.2 x 23T	48-2015	48-1015	48-1115	48-3015	48-3015	48-3015	Audi & Volkswagen
1 1/8" x 10T	48-2016	48-1016	48-1116	48-3016	48-3016	48-3016	Audi & Volkswagen
22.1mm x 28T	48-2017	48-1017	48-1117	48-3017	48-3017	48-3017	Jaguar,GM (USA) & Rover
29mm x 10T	48-2018	48-1018	48-1118	48-3018	48-3018	48-3018	Audi & Volkswagen
19.3mm x 18T	48-2019	48-1019	48-1119	48-3019	48-3019	48-3019	Peugeot & Renault
22mm x 26T	48-2020	48-1020	48-1120	48-3020	48-3020	48-3020	Suzuki
19mm x 14T	48-2021	48-1021	48-1121	48-3021	48-3021	48-3021	Renault
22mm x 20T	48-2022	48-1022	48-1122	48-3022	48-3022	48-3022	Opel & Vauxhall
7/8" x 10T	48-2023	48-1023	48-1123	48-3023	48-3023	48-3023	Honda & Rover
25.4mm x 24T	48-2024	48-1024	48-1124	48-3024	48-3024	48-3024	Austin Healey,Hillman,MG & Rover
25.9mm x 24T	48-2025	48-1025	48-1125	48-3025	48-3025	48-3025	Honda & Rover
1 1/16" x 10T	48-2026	48-1026	48-1126	48-3026	48-3026	48-3026	Ford (USA)
1 5/32" x 26T	48-2027	48-1027	48-1127	48-3027	48-3027	48-3027	GM (USA)
20mm x 18T	48-2028	48-1028	48-1128	48-3028	48-3028	48-3028	Nissan & Skoda
28.7mm x 26T	48-2029	48-1029	48-1129	48-3029	48-3029	48-3029	Mercedes
1" x 10T	48-2030	48-1030	48-1130	48-3030	48-3030	48-3030	Alfa Romeo, Talbot & Triumph.
25.2mm x 24T	48-2031	48-1031	48-1131	48-3031	48-3031	48-3031	Subaru
25mm x 22T	48-2032	48-1032	48-1132	48-3032	48-3032	48-3032	Volvo
21.8mm x 20T	48-2033	48-1033	48-1133	48-3033	48-3033	48-3033	Volvo
35mm x 10T	48-2035	48-1035	48-1135	48-3035	48-3035	48-3035	BMW
28mm x 25T	48-2038	48-1038	48-1138	48-3038	48-3038	48-3038	Lotus & Vauxhall

184mm Ø Sintered, Cerametallic & Organic Drive Plate Hub Spline Details

Spline Data	Geared		Geared		Application
	Hub Plate Sintered	Geared Hub Plate Cerametallic	Hub Plate Cerametallic	Geared Hub Plate Organic	
Ø Teeth		4 Paddle	6 Paddle		
28mm x 20T	48-2039	48-1039	48-1139	48-3039	Toyota
22.5mm x 19T	48-2040	48-1040	48-1140	48-3040	Toyota
1 3/8" x 10T	48-2041	48-1041	48-1141	48-3041	Ferrari
19mm x 17T	48-2042	48-1042	48-1142	48-3042	SAAB
25.4mm x 23T	48-2043	48-1043	48-1143	48-3043	Sadev Gearbox spline
29mm x 22T	48-2044	48-1044	48-1144	48-3044	BMW
28mm x 25T	48-2045	48-1045	48-1145	48-3045	Ferrari
20mm x 19T	48-2046	48-1046	48-1146	48-3046	Honda
17.3mm x 20T	48-2047	48-1047	48-1147	48-3047	Fiat, Renault
35mm x 26T	48-2048	48-1048	48-1148	48-3048	BMW
24.5mm x 21T	48-2049	48-1049	48-1149	48-3049	Renault
29mm x 26T	48-2050	48-1050	48-1150	48-3050	Audi & Volkswagen
1" x 6T	48-2051	48-1051	48-1151	48-3051	Ferrari
24.3mm x 21T	48-2052	48-1052	48-1152	48-3052	Lotus
7/8" x 6T	48-2053	48-1053	48-1153	48-3053	Alfa Romeo
25mm x 6T	48-2054	48-1054	48-1154	48-3054	1929 OM
34mm x 6T	48-2055	48-1055	48-1155	48-3055	Lancia Aurelia
38mm x 10T	48-2056	48-1056	48-1156	48-3056	Lancia Aurelia
33mm x 30T	48-2057	48-1057	48-1157	48-3057	Ferrari Flywheel HF 9426
27.2mm x 10T	48-2058	48-1058	48-1158	48-3058	Lancia
Geared Floating Hub	48-2090	48-2091	48-2092	48-2093	Geared Floating Plate

200mm Ø 'Helix' Racing Clutch Range



Series Part No. 68-110 & 68-120

Cover Assembly is of a lug drive configuration one piece aluminium alloy. This design allows the dust from the friction material to escape and reduces the heat build up. These are used with either cerametallic or organic friction faced drive plates in either single or twin plate formats



Series Part No. 70-1000

A sprung hub centre drive plate with heavy duty metal backed organic linings to give a more progressive engagement of the clutch. Only available as a single plate clutch and must be used with the 68-110 series of clutch cover assemblies. Can be used for road or light competition applications



Series Part No 71-1000

A rigid hub drive plate with heavy duty metal backed organic linings. Normally used with the twin plate clutch. 68-120 series of clutch cover assemblies. Can be used for road or light competition applications.



Series Part No. 77-1100

4 paddle sprung centre cerametallic drive plate. Single plate configuration. This design is mainly used for rallying or racing where the damper springs provide a cushion to the impact of clutch engagement on the driveline components. Can only be used with the 68-110 series of clutch cover assemblies



Series Part No. 77-1100

6 paddle sprung centre cerametallic drive plate. Single plate configuration. Can only be used with the 68-110 series of clutch cover assemblies.



Series Part No. 78-1001

4 paddle rigid hub cerametallic drive plate. Single or twin plate format
Cerametallic drive plates have cerametallic segments riveted onto a steel back plate these give the clutch a higher torque capacity than when using an organic faced drive plate.

This design is mainly used for rallying or racing, especially endurance



Series Part No. 78-1101

6 paddle rigid hub cerametallic drive plate. Single or twin plate format



Series Part No 68-110TP & 68-120TP

Cover assembly design & dimensions as per 68-110 & 68-120 series but fitted with a release plate to facilitate the use of a flat face release bearing.



Series Part No 47-1001 & 47-1090

Cerametallic 4 paddle drive plates with a main geared hub (47-1001) and floating hub drive plate (47-1090)



Series Part No 47-1101 & 47-1091

Cermetallic 6 paddle drive plates with a main geared hub (47-1101) and floating hub drive plate (47-1091)



Series Part No 47-2001 & 47-1092

Organic drive plates with a main geared hub (47-2001) and floating hub drive plate (47-1092) shown as a set

68-110
Ø200mm, Single Drive Plate



Cover	Torque Capacity	
68-110R	348Nm [256lb/ft]	Cerametallic Drive Plate
68-110G	514Nm [378lb/ft]	Cerametallic Drive Plate
68-110R	292Nm [215lb/ft]	Organic Drive Plate
68-110G	350Nm [257lb/ft]	Organic Drive Plate

Cover	Release Load	Release Bearing Travel (Max)
68-110R	335Kg	
68-110G	358Kg	7.50mm

Set-Up Height (New)		Set-Up Height (Worn)	
68-110R	29.55mm	68-110R	33.40mm
68-110G	29.30mm	68-110G	33.20mm

Drive Plates

	Series Part No	Thickness New [Nom]	Thickness Worn [Min]		Weight
Organic (Rigid)	71-1000	7.20 mm	6.30 mm	[See chart for spline details]	4.00 Kg
Organic (Sprung)	70-1000	7.20 mm	6.30 mm	[See chart for spline details]	4.30 Kg
4 Paddle (Rigid)	78-1000	7.20 mm	6.30 mm	[See chart for spline details]	3.85 Kg
4 Paddle (Sprung)	77-1000	7.20 mm	6.30 mm	[See chart for spline details]	4.40 Kg
6 Paddle (Rigid)	78-1100	7.20 mm	6.30 mm	[See chart for spline details]	4.15 Kg
6 Paddle (Sprung)	77-1100	7.20 mm	6.30 mm	[See chart for spline details]	4.60 Kg

Other configurations available see index.

Spare Parts

Wear Clips	184-61B
Pressure Plate	200-12
Push off Springs (3)	68-POSA

Applications

Organic Drive Plate Rigid Hub	Road
Organic Drive Plate Sprung Hub	Road
Paddle Rigid Hub	Race
Paddle Sprung Hub	Race/Rally

Release Bearing: Must have curved face with a fulcrum point of between 52mm to 58mm.

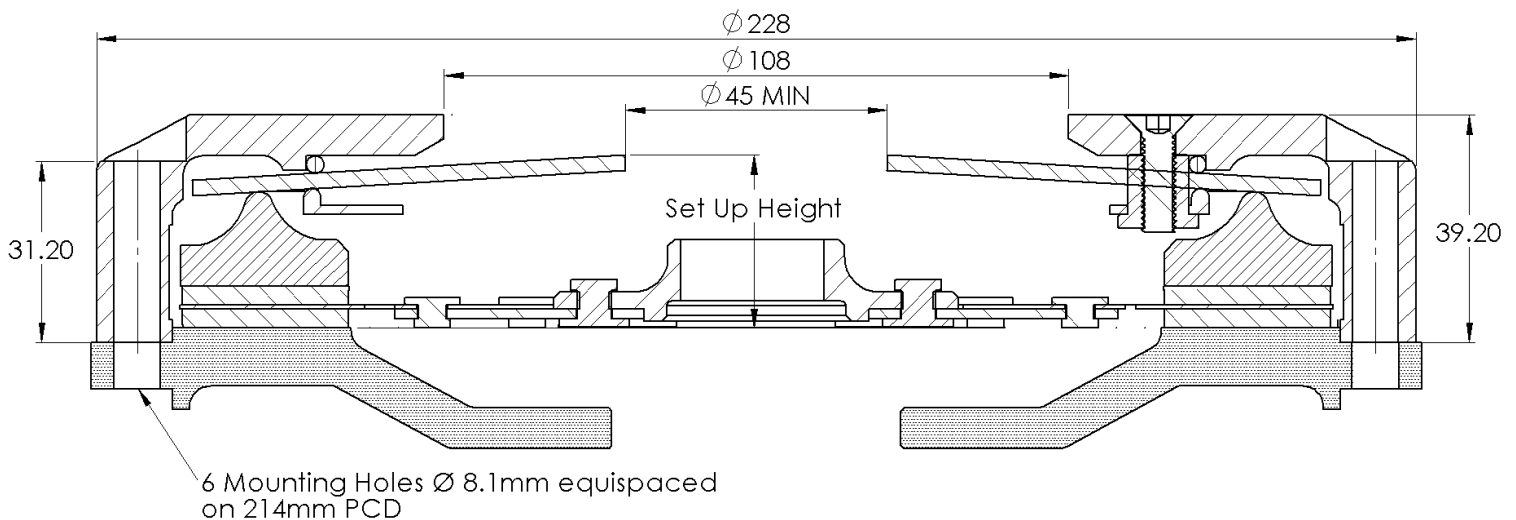

68-110c

Ø200mm, Single Drive Plate
Curly Tip Diaphragm Spring



Cover	Torque Capacity	
68-110Rc	348Nm [256lb/ft]	Cerametallic Drive Plate
68-110Gc	514Nm [378lb/ft]	Cerametallic Drive Plate
68-110Rc	292Nm [215lb/ft]	Organic Drive Plate
68-110Gc	350Nm [257lb/ft]	Organic Drive Plate

Cover	Release Load	Release Bearing Travel (Max)
68-110Rc	335Kg	7.50mm
68-110Gc	358Kg	

Set-Up Height (New)

68-110Rc	32.55mm
68-110Gc	32.30mm

Set-Up Height (Worn)

68-110Rc	36.40mm
68-110Gc	36.20mm

Drive Plates

	Series Part No	Thickness New [Nom]	Thickness Worn [Min]		Weight
Organic (Rigid)	71-1000	7.20 mm	6.30 mm	[See chart for spline details]	4.00 Kg
Organic (Sprung)	70-1000	7.20 mm	6.30 mm	[See chart for spline details]	4.30 Kg
4 Paddle (Rigid)	78-1000	7.20 mm	6.30 mm	[See chart for spline details]	3.85 Kg
4 Paddle (Sprung)	77-1000	7.20 mm	6.30 mm	[See chart for spline details]	4.40 Kg
6 Paddle (Rigid)	78-1100	7.20 mm	6.30 mm	[See chart for spline details]	4.15 Kg
6 Paddle (Sprung)	77-1100	7.20 mm	6.30 mm	[See chart for spline details]	4.60 Kg

Other configurations available see index.

Spare Parts

Wear Clips	184-61B
Pressure Plate	200-12
Push off Springs (3)	68-POSA

Applications

Organic Drive Plate Rigid Hub	Road
Organic Drive Plate Sprung Hub	Road
Paddle Rigid Hub	Race
Paddle Sprung Hub	Race/Rally

Release Bearing: Must have flat face with a fulcrum point of between 52mm to 58mm.

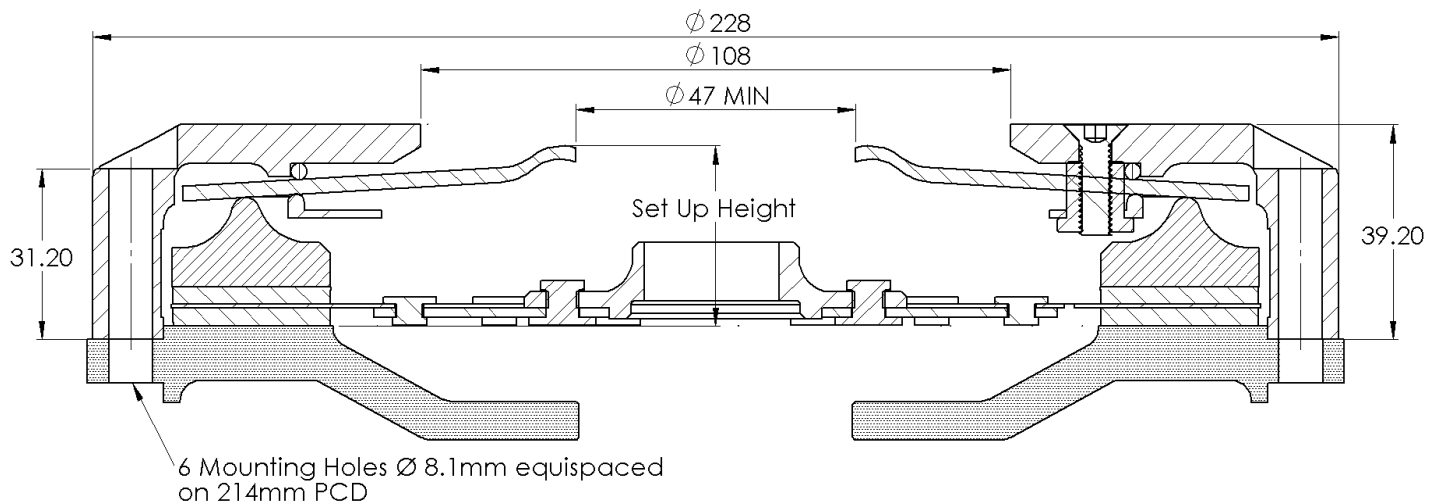

68-120
Ø200mm, Twin Drive Plate



Cover	Torque Capacity	
68-120R	499Nm [367lb/ft]	Cerametallic Drive Plate
68-120G	740Nm [544lb/ft]	Cerametallic Drive Plate
68-120R	413Nm [304lb/ft]	Organic Drive Plate
68-120G	611Nm [449lb/ft]	Organic Drive Plate

Cover	Release Load	Release Bearing Travel (Max)
68-120R	335Kg	7.50mm
68-120G	358Kg	

Set-Up Height (New)	
68-120R	41.60mm
68-120G	41.70mm

Set-Up Height (Worn)	
68-120R	45.50mm
68-120G	45.65mm

Drive Plates

	Series Part No	Thickness New [Nom]	Thickness Worn [Min]		Weight
Organic (Rigid)	71-1000	7.20 mm	6.80 mm	[See chart for spline details]	5.35 Kg
4 Paddle (Rigid)	78-1000	7.20 mm	6.80 mm	[See chart for spline details]	5.15 Kg
6 Paddle (Rigid)	78-1100	7.20 mm	6.80 mm	[See chart for spline details]	6.55 Kg

Other configurations available see index.

Spare Parts

Wear Clips	184-61D
Pressure Plate	200-13
Interplate	200-11
Push off Springs (3)	68-POSA
Push off Springs (3)	68-POSB

Applications

Organic Drive Plate Rigid Hub	Road
Paddle Rigid Hub	Race

Release Bearing: Must have curved face with a fulcrum point of between 52mm to 58mm.

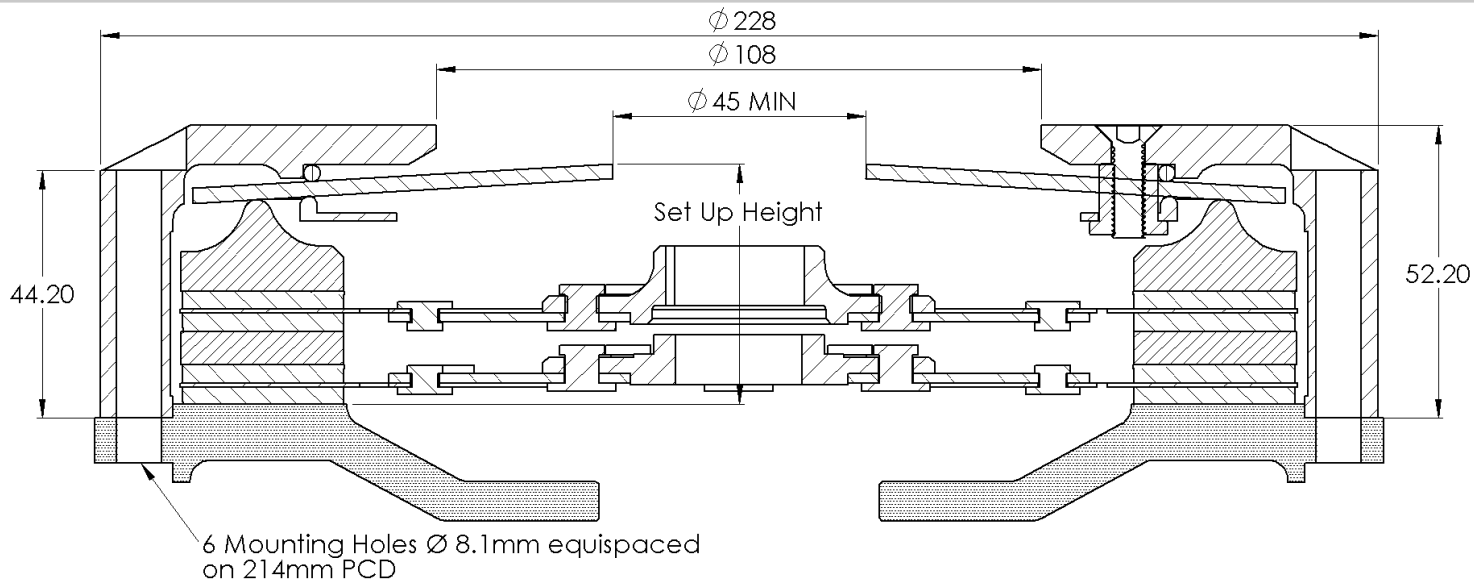

68-120c

Ø200mm, Twin Drive Plate
Curly Tip Diaphragm Spring

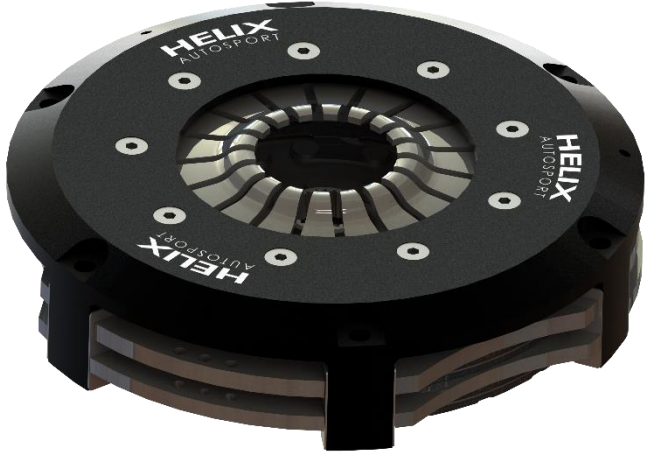

Cover	Torque Capacity	
68-120Rc	499Nm [367lb/ft]	Cerametallic Drive Plate
68-120Gc	740Nm [544lb/ft]	Cerametallic Drive Plate
68-120Rc	413Nm [304lb/ft]	Organic Drive Plate
68-120Gc	611Nm [449lb/ft]	Organic Drive Plate

Cover	Release Load	Release Bearing Travel (Max)
68-120Rc	335Kg	7.50mm
68-120Gc	358Kg	

Set-Up Height (New)

68-120Rc	44.60mm
68-120Gc	44.70mm

Set-Up Height (Worn)

68-120Rc	48.50mm
68-120Gc	48.65mm

Drive Plates

	Series Part No	Thickness New [Nom]	Thickness Worn [Min]		Weight
Organic (Rigid)	71-1000	7.20 mm	6.80 mm	[See chart for spline details]	5.35 Kg
4 Paddle (Rigid)	78-1000	7.20 mm	6.80 mm	[See chart for spline details]	5.15 Kg
6 Paddle (Rigid)	78-1100	7.20 mm	6.80 mm	[See chart for spline details]	6.55 Kg

Other configurations available see index.

Spare Parts

Wear Clips	184-61D
Pressure Plate	200-13
Interplate	200-11
Push off Springs (3)	68-POSA
Push off Springs (3)	68-POSB

Applications

Organic Drive Plate Rigid Hub	Road
Paddle Rigid Hub	Race

Release Bearing: Must have flat face with a fulcrum point of between 52mm to 58mm.

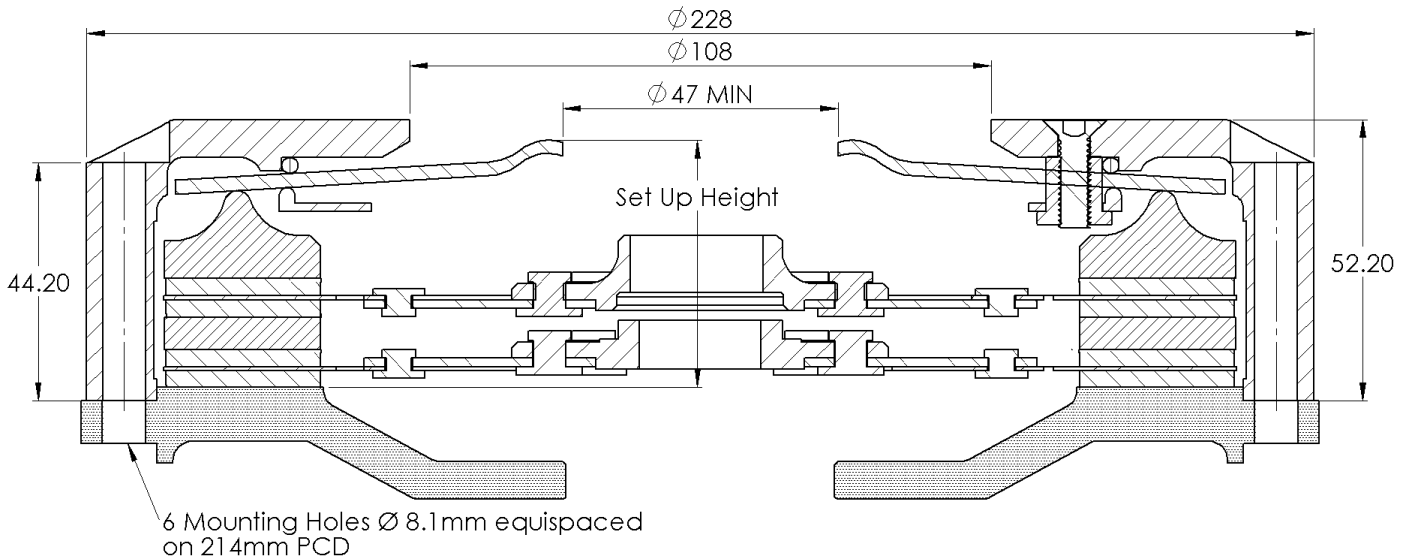

200mm Ø Cerametallic & Organic Drive Plate Hub Spline Details

Spline Data	Organic Sprung Hub	Organic Rigid	4 Paddle Cerametallic Sprung Hub	6 Paddle Cerametallic Sprung Hub	4 Paddle Cerametallic Rigid Hub	6 Paddle Cerametallic Rigid Hub	Application
25.4mm x 23T	70-1001	71-1001	77-1001	77-1101	78-1001	78-1101	Ford/Mitsubishi, MG & Porsche
22.5mm x 20T	70-1002	71-1002	77-1002	77-1102	78-1002	78-1102	Ford, Fiat, Mitsubishi & Porsche
24.3mm x 22T	70-1003	71-1003	77-1003	77-1103	78-1003	78-1103	Mazda
29mm x 21T		71-1004			78-1004	78-1104	Toyota
25.6mm x 24T	70-1005	71-1005	77-1005	77-1105	78-1005	78-1105	Nissan
24mm x 21T	70-1006	71-1006	77-1006	77-1106	78-1006	78-1106	Renault
24mm x 21T	70-1007	71-1007	77-1007	77-1107	78-1007	78-1107	Toyota
25mm x 14T	70-1008	71-1008	77-1008	77-1108	78-1008	78-1108	BMW Mini, Opel & Vauxhall
29mm x 10T		71-1009			78-1009	78-1109	BMW, Ford & Mercedes
21mm x 18T	70-1010	71-1010	77-1010	77-1110	78-1010	78-1110	Peugeot
20mm x 17T	70-1011	71-1011	77-1011	77-1111	78-1011	78-1111	Ford & Fiat
20.4mm x 24T	70-1012	71-1012	77-1012	77-1112	78-1012	78-1112	Opel, Vauxhall & Volkswagen
22mm x 19T	70-1013	71-1013	77-1013	77-1113	78-1013	78-1113	Alfa Romeo
1 1/4" x 10T		71-1014			78-1014	78-1114	Aston Martin, Ferrari & Triumph
24.2 x 23T	70-1015	71-1015	77-1015	77-1115	78-1015	78-1115	Audi & Volkswagen
1 1/8" x 10T		71-1016			78-1016	78-1116	Jaguar, GM (USA) & Rover
22.1mm x 28T	70-1017	71-1017	77-1017	77-1117	78-1017	78-1117	Audi & Volkswagen
29mm x 10T		71-1018			78-1018	78-1118	Peugeot & Renault
19.3mm x 18T	70-1019	71-1019	77-1019	77-1119	78-1019	78-1119	Suzuki
22mm x 26T	70-1020	71-1020	77-1020	77-1120	78-1020	78-1120	Renault
19mm x 14T	70-1021	71-1021	77-1021	77-1121	78-1021	78-1121	Opel & Vauxhall
22mm x 20T	70-1022	71-1022	77-1022	77-1122	78-1022	78-1122	Honda & Rover
7/8" x 10T	70-1023	71-1023	77-1023	77-1123	78-1023	78-1123	Austin Healey, Hillman, MG & Rover
25.4mm x 24T	70-1024	71-1024	77-1024	77-1124	78-1024	78-1124	Honda & Rover
25.9mm x 24T	70-1025	71-1025	77-1025	77-1125	78-1025	78-1125	Honda
1 1/16" x 10T		71-1026			78-1026	78-1126	Ford (USA)
1 5/32" x 26T		71-1027			78-1027	78-1127	GM (USA)
20mm x 18T	70-1028	71-1028	77-1028	77-1128	78-1028	78-1128	Nissan & Skoda
28.7mm x 26T		71-1029			78-1029	49-1029	Mercedes
1" x 10T	70-1030	71-1030	77-1030	77-1130	78-1030	78-1130	Alfa Romeo, Talbot & Triumph.
25.2mm x 24T	70-1031	71-1031	77-1031	77-1131	78-1031	78-1131	Subaru
25mm x 22T	70-1032	71-1032	77-1032	77-1132	78-1032	78-1132	Volvo
21.8mm x 20T	70-1033	71-1033	77-1033	77-1133	78-1033	78-1133	Volvo
35mm x 10T		71-1035			78-1035	78-1135	BMW
28mm x 25T		71-1038			78-1038	78-1138	Lotus & Vauxhall

200mm Ø Cerametallic & Organic Drive Plate Hub Spline Details.

Spline Data	Organic		Cerametallic				Application
	Sprung Hub	Rigid	4 Paddle Sprung Hub	6 Paddle Sprung Hub	4 Paddle Rigid Hub	6 Paddle Rigid Hub	
Ø Teeth							
28mm x 20T	70-1039	71-1039	77-1039	77-1139	78-1039	78-1139	Toyota
22.5mm x 19T	70-1040	71-1040	77-1040	77-1140	78-1040	78-1140	Toyota
1 3/8" x 10T		71-1041			78-1041	78-1141	Ferrari
19mm x 17T	70-1042	71-1042	77-1042	77-1142	78-1042	78-1142	SAAB
25.4mm x 23T	70-1043	71-1043	77-1043	77-1143	78-1043	78-1143	Sadev Gearbox spline
29mm x 22T		71-1044			78-1044	78-1144	BMW
28mm x 25T		71-1045			78-1045	78-1145	Ferrari
20mm x 19T	70-1046	71-1046	77-1046	77-1146	78-1046	78-1146	Honda
17.3mm x 20T	70-1047	71-1047	77-1047	77-1147	78-1047	78-1147	Fiat, Renault
35mm x 26T		71-1048			78-1048	78-1148	BMW
24.5mm x 21T	70-1049	71-1049	77-1049	77-1149	78-1049	78-1149	Renault
29mm x 26T		71-1050			78-1050	78-1150	Audi, Volkswagen
1" x 6T	70-1051	71-1051	77-1051	77-1151	78-1051	78-1151	Ferrari
24.3mm x 21T	70-1052	71-1052	77-1052	77-1152	78-1052	78-1152	Lotus
7/8" x 6T	70-1053	71-1053	77-1053	77-1153	78-1053	78-1153	Alfa Romeo
25mm x 6T	70-1054	71-1054	77-1054	77-1153	78-1054	78-1154	OM 1929
34mm x 6T	70-1055	71-1055	77-1055	77-1155	78-1055	78-1155	Lancia
38mm x 10T	70-1056	71-1056	77-1056	77-1156	78-1056	78-1156	Ferrari flywheel HF 9426
33mm x 30T	70-1057	71-1057	77-1057	77-1157	78-1057	78-1157	Lancia
27.2 mm x 10T	70-1058	71-1058	77-1058	77-1158	78-1058	78-1158	

200mm Ø Cerametallic & Organic Drive Plate Hub Spline Details

Spline Data	Geared		Application
	Hub Plate Cerametallic 4 Paddle	Geared Hub Plate Cerametallic 6 Paddle	
25.4mm x 23T	47-1001	47-1101	Ford,Mitsubishi,MG & Porsche
22.5mm x 20T	47-1002	47-1102	Ford, Fiat,Mitsubishi & Porsche
24.3mm x 22T	47-1003	47-1103	Mazda
29mm x 21T	47-1004	47-1104	Toyota
25.6mm x 24T	47-1005	47-1105	Nissan
24mm x 21T	47-1006	47-1106	Renault
24mm x 21T	47-1007	47-1107	Toyota
25mm x 14T	47-1008	47-1108	BMW Mirni,Opel & Vauxhall
29mm x 10T	47-1009	47-1109	BMW, Ford & Mercedes
21mm x 18T	47-1010	47-1110	Peugeot
20mm x 17T	47-1011	47-1111	Ford & Fiat
20.4mm x 24T	47-1012	47-1112	Opel, Vauxhall & Volkswagen
22mm x 19T	47-1013	47-1113	Alfa Romeo
1 1/4" x 10T	47-1014	47-1114	Aston Martin,Ferrari & Triumph
24.2 x 23T	47-1015	47-1115	Audi & Volkswagen
1 1/8" x 10T	47-1016	47-1116	Jaguar,GM(USA) & Rover
22.1mm x 28T	47-1017	47-1117	Audi & Volkswagen
29mm x 10T	47-1018	47-1118	Peugeot & Renault
19.3mm x 18T	47-1019	47-1119	Suzuki
22mm x 26T	47-1020	47-1120	Renault
19mm x 14T	47-1021	47-1121	Opel & Vauxhall
22mm x 20T	47-1022	47-1122	Honda & Rover
7/8" x 10T	47-1023	47-1123	Austin Healey,Hillman,MG & Rover
25.4mm x 24T	47-1024	47-1124	Honda & Rover
25.9mm x 24T	47-1025	47-1125	Honda
1 1/16" x 10T	47-1026	47-1126	Ford (USA)
1 5/32" x 26T	47-1027	47-1127	GM (USA)
20mm x 18T	47-1028	47-1128	Nissan & Skoda
28.7mm x 26T	47-1029	47-1128	Mercedes
1" x 10T	47-1030	47-1130	Alfa Romeo, Talbot & Triumph.
25.2mm x 24T	47-1031	47-1131	Subaru
25mm x 22T	47-1032	47-1132	Volvo
21.8mm x 20T	47-1033	47-1133	Volvo
35mm x 10T	47-1035	47-1135	BMW
28mm x 25T	47-1038	47-1138	Lotus & Vauxhall

200mm Ø Cerametallic & Organic Drive Plate Hub Spline Details.

Spline Data	Gearing		Application
	Cerametallic Hub Plate 4 Paddle	Cerametallic Hub Plate 6 Paddle	
28mm x 20T	47-1039	47-1139	Toyota
22.5mm x 19T	47-1040	47-1140	Toyota
1 3/8" x 10T	47-1041	47-1141	Ferrari
19mm x 17T	47-1042	47-1142	SAAB
25.4mm x 23T	47-1043	47-1143	Sadev Gearbox spline
29mm x 22T	47-1044	47-1144	BMW
28mm x 25T	47-1045	47-1145	Ferrari
20mm x 19T	47-1046	47-1146	Honda
17.3mm x 20T	47-1047	47-1147	Fiat, Renault
35mm x 26T	47-1048	47-1148	BMW
24.5mm x 21T	47-1049	47-1149	Renault
29mm x 26T	47-1050	47-1150	Audi, Volkswagen
1" x 6T	47-1051	47-1151	Ferrari
24.3mm x 21T	47-1052	47-1152	Lotus
7/8" x 6T	47-1053	47-1153	Alfa Romeo
25mm x 6T	47-1054	47-1154	
34mm x 6T	47-1055	47-1155	OM 1929
38mm x 10T	47-1056	47-1156	Lancia
33mm x 30T	47-1057	47-1157	Ferrari flywheel HF 9426
27.2mm x 10T	47-1058	47-1158	Lancia
Gearing Floating Plate	47-1090	47-1091	Gearing Floating Plate
		47-1092	

215mm Ø 'HELIX' Racing Clutch Range



Series Part No. 69-110 & 69-120

Cover Assembly is of a lug drive configuration one piece aluminium alloy. This design allows the dust from the friction material to escape and reduces the heat build up. These are used with either cerametallic or organic friction faced drive plates in either single or twin plate formats.



Series Part No. 70-2000

A sprung hub centre drive plate with heavy duty metal backed organic linings to give a more progressive engagement of the clutch. Only available as a single plate clutch and must be used with the 69-110 series of clutch cover assemblies.



Series Part No. 71-2000 & 71-3000

A rigid hub drive plate with heavy duty metal backed organic linings. Normally used with the twin plate clutch for a more progressive operation.

Series 71-2000 for single plate clutch. Thickness 8.40mm
Series 71-3000 for twin plate clutch. Thickness 7.20mm



Series Part No. 77-2000

4 paddle sprung centre cerametallic drive plate, single plate configuration. This design is mainly used for rallying and racing where the damper springs provide a cushion to the impact of clutch engagement on the driveline components. Can only be used with the 69-110 series of clutch cover assemblies.



Series Part No. 77-2100

6 paddle sprung centre cerametallic drive plate. Single plate configuration. Can only be used with the 69-110 series of clutch cover assemblies.

Series Part No. 78-2000 & 78-3000



4 paddle rigid hub cerametallic drive plate. Single or twin plate format. Cerametallic drive plates have cerametallic segments riveted onto a steel back plate these give the clutch a higher torque capacity than when using an organic faced drive plate. This design is mainly for rallying or racing, especially endurance.

Series 78-2000 for single plate clutch. Thickness 8.40mm

Series 78-3000 for twin plate clutch. Thickness 7.20mm



Series Part No. 78-2100 & 78-3100

6 paddle rigid hub cerametallic drive plate. Single or twin plate format.

Series 78-2100 for a single plate clutch. Thickness 8.40mm

Series 78-3100 for a twin plate clutch. Thickness 7.20mm



Series Part No 69-110TP & 69-120TP

Cover assembly design & dimensions are as per 69-110 & 69-120 but fitted with a release plate to facilitate the use of a flat face release bearing



Series Part No 46-1001 & 46-1090

Cerametallic 4 paddle drive plates with a main geared hub (46-1001) and floating hub drive plate (46-1090)



Series Part No 46-1101 & 46-1091

Cerametallic 6 paddle drive plates with a main geared hub (46-1101) and floating hub drive plate (46-1091)



Series Part No 46-2001 & 46-1092

Organic drive plates with a main geared hub (46-2001) and floating hub drive plate (46-1092) shown as a set

69-110
Ø215mm, Single Drive Plate



Cover	Torque Capacity	
69-110G	462Nm [340lb/ft]	Cerametallic Drive Plate
69-110Y	606Nm [446lb/ft]	Cerametallic Drive Plate
69-110G	371Nm [273lb/ft]	Organic Drive Plate
69-110Y	496Nm [365lb/ft]	Organic Drive Plate

Cover	Release Load	Release Bearing Travel (Max)
69-110G	290Kg	
69-110Y	330Kg	8.00mm

Set-Up Height (New)	
69-110G	33.00mm
69-110Y	32.30mm

Set-Up Height (Worn)	
69-110R	36.90mm
69-110G	36.20mm

Drive Plates

	Series Part No	Thickness New [Nom]	Thickness Worn [Min]		Weight
Organic (Rigid)	71-2000	8.40mm	7.40mm	[See chart for spline details]	4.60 Kg
Organic (Sprung)	70-2000	8.40mm	7.40mm	[See chart for spline details]	5.10 Kg
4 Paddle (Rigid)	78-2000	8.40mm	7.40mm	[See chart for spline details]	4.70 Kg
4 Paddle (Sprung)	77-2000	8.40mm	7.40mm	[See chart for spline details]	5.30 Kg
6 Paddle (Rigid)	78-2100	8.40mm	7.40mm	[See chart for spline details]	5.00 Kg
6 Paddle (Sprung)	77-2100	8.40mm	7.40mm	[See chart for spline details]	5.80 Kg

Other configurations available see index.

Spare Parts

Wear Clips	215-61A
Pressure Plate	215-15
Push off Springs (3)	215-POSB

Applications

Organic Drive Plate Rigid Hub	Road
Organic Drive Plate Sprung Hub	Road
Paddle Rigid Hub	Race
Paddle Sprung Hub	Race/Rally

Release Bearing: Must have curved face with a fulcrum point of between 52mm to 58mm.

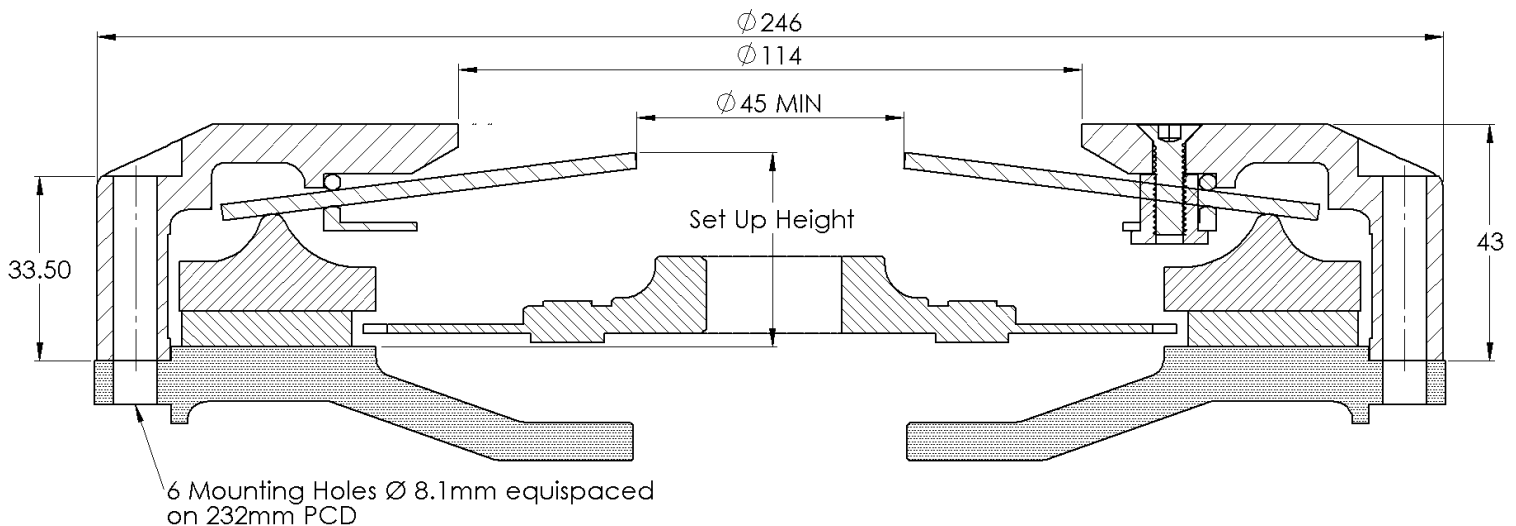

69-110c

Ø215mm, Single Drive Plate
Curly Tip Diaphragm Spring



Cover	Torque Capacity	
69-110Gc	462Nm [340lb/ft]	Cerametallic Drive Plate
69-110Yc	606Nm [446lb/ft]	Cerametallic Drive Plate
69-110Gc	371Nm [273lb/ft]	Organic Drive Plate
69-110Yc	496Nm [365lb/ft]	Organic Drive Plate

Cover	Release Load	Release Bearing Travel (Max)
69-110Gc	290Kg	8.00mm
69-110Yc	330Kg	

Set-Up Height (New)

69-110Gc	36.00mm
69-110Yc	35.30mm

Set-Up Height (Worn)

69-110Rc	39.90mm
69-110Gc	39.20mm

Drive Plates

	Series Part No	Thickness New [Nom]	Thickness Worn [Min]		Weight
Organic (Rigid)	71-2000	8.40mm	7.40mm	[See chart for spline details]	4.60 Kg
Organic (Sprung)	70-2000	8.40mm	7.40mm	[See chart for spline details]	5.10 Kg
4 Paddle (Rigid)	78-2000	8.40mm	7.40mm	[See chart for spline details]	4.70 Kg
4 Paddle (Sprung)	77-2000	8.40mm	7.40mm	[See chart for spline details]	5.30 Kg
6 Paddle (Rigid)	78-2100	8.40mm	7.40mm	[See chart for spline details]	5.00 Kg
6 Paddle (Sprung)	77-2100	8.40mm	7.40mm	[See chart for spline details]	5.80 Kg

Other configurations available see index.

Spare Parts

Wear Clips	215-61A
Pressure Plate	215-15
Push off Springs (3)	215-POSB

Applications

Organic Drive Plate Rigid Hub	Road
Organic Drive Plate Sprung Hub	Road
Paddle Rigid Hub	Race
Paddle Sprung Hub	Race/Rally

Release Bearing: Must have flat face with a fulcrum point of between 52mm to 58mm.

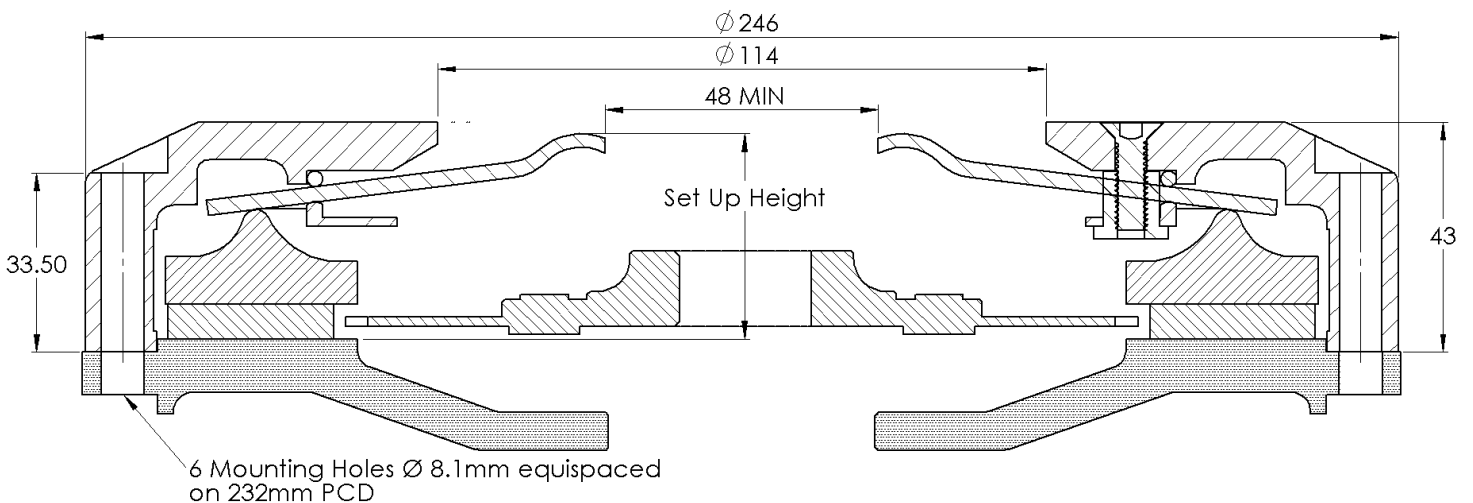

69-120
Ø215mm, Twin Drive Plate



Cover	Torque Capacity	
69-120G	578Nm [425lb/ft]	Cerametallic Drive Plate
69-120Y	868Nm [638lb/ft]	Cerametallic Drive Plate
69-120G	486Nm [357lb/ft]	Organic Drive Plate
69-120Y	695Nm [511lb/ft]	Organic Drive Plate

Cover	Release Load	Release Bearing Travel (Max)
69-120G	290Kg	8.00mm
69-120Y	330Kg	

Set-Up Height (New)		Set-Up Height (Worn)	
69-120G	47.30mm	69-120G	51.60mm
69-120Y	47.00mm	69-120Y	51.10mm

Drive Plates

	Series Part No	Thickness New [Nom]	Thickness Worn [Min]		Weight
Organic (Rigid)	71-3000	7.20 mm	6.80 mm	[See chart for spline details]	7.10 Kg
4 Paddle (Rigid)	78-3000	7.20 mm	6.80 mm	[See chart for spline details]	7.20 Kg
6 Paddle (Rigid)	78-3100	7.20 mm	6.80 mm	[See chart for spline details]	7.80 Kg

Other configurations available see index.

Spare Parts

Applications

Wear Clips	215-61B	Organic Drive Plate Rigid Hub	Road
Pressure Plate	215-16	Paddle Rigid Hub	Race
Interplate	215-11		
Push off Springs (3)	215-POSA		
Push off Springs (3)	215-POSB		

Release Bearing: Must have curved face with a fulcrum point of between 52mm to 58mm.

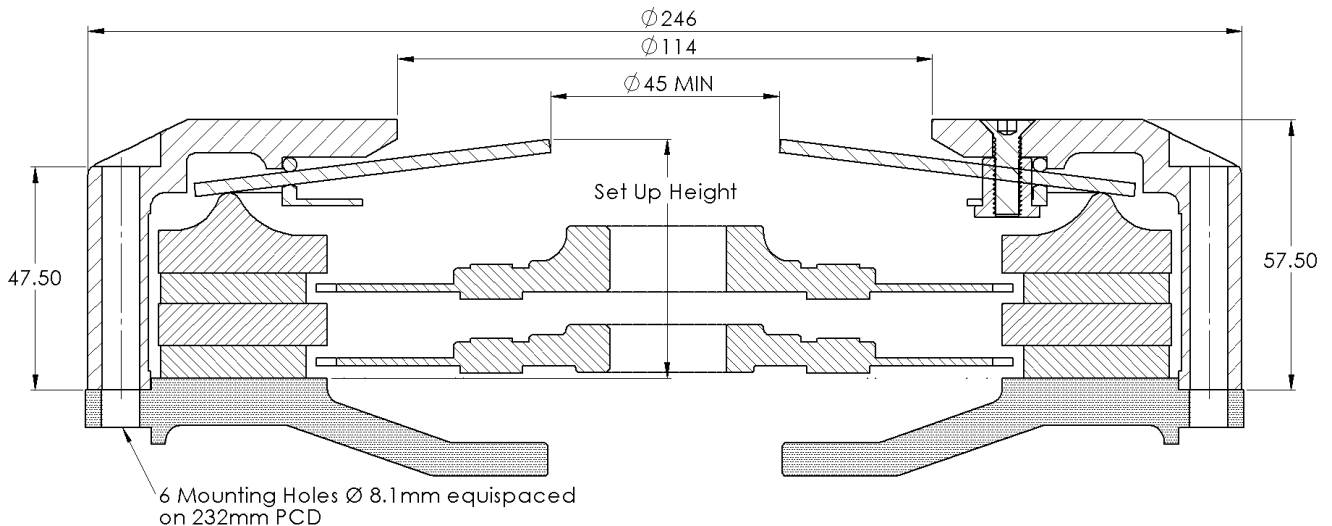

69-120c

Ø215mm, Twin Drive Plate
Curly Tip Diaphragm Spring



Cover	Torque Capacity	
69-120Gc	578Nm [425lb/ft]	Cerametallic Drive Plate
69-120Yc	868Nm [638lb/ft]	Cerametallic Drive Plate
69-120Gc	486Nm [357lb/ft]	Organic Drive Plate
69-120Yc	695Nm [511lb/ft]	Organic Drive Plate

Cover	Release Load	Release Bearing Travel (Max)
69-120Gc	290Kg	8.00mm
69-120Yc	330Kg	

Set-Up Height (New)

69-120Gc	50.30mm
69-120Yc	50.00mm

Set-Up Height (Worn)

69-120Gc	54.60mm
69-120Yc	54.10mm

Drive Plates

	Series Part No	Thickness New [Nom]	Thickness Worn [Min]		Weight
Organic (Rigid)	71-3000	7.20 mm	6.80 mm	[See chart for spline details]	7.10 Kg
4 Paddle (Rigid)	78-3000	7.20 mm	6.80 mm	[See chart for spline details]	7.20 Kg
6 Paddle (Rigid)	78-3100	7.20 mm	6.80 mm	[See chart for spline details]	7.80 Kg

Other configurations available see index.

Spare Parts

Wear Clips	215-61B
Pressure Plate	215-16
Interplate	215-11
Push off Springs (3)	215-POSA
Push off Springs (3)	215-POSB

Applications

Organic Drive Plate Rigid Hub	Road
Paddle Rigid Hub	Race

Release Bearing: Must have flat face with a fulcrum point of between 52mm to 58mm.

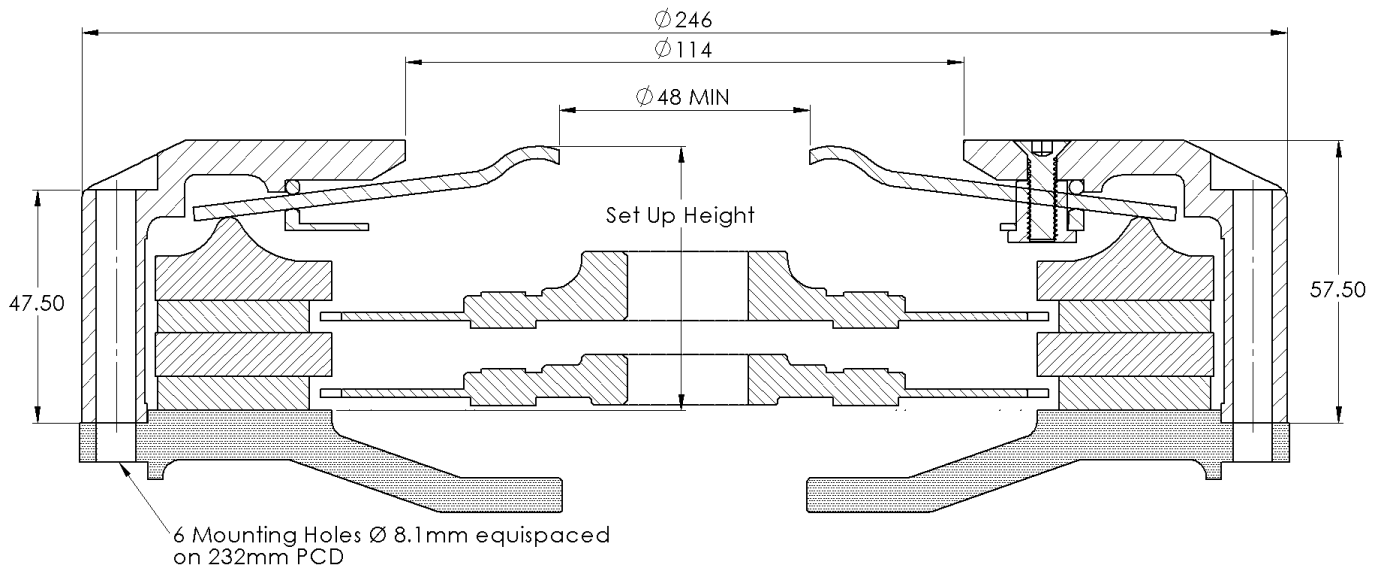

215mm Ø Cerametallic & Organic Drive Plate Hub Spine Details

Spine Data	Organic Sprung Hub		Organic Rigid		Cerametallic Sprung Hub		Cerametallic Rigid Hub		Cerametallic Sprung Hub		Cerametallic Rigid Hub		Application
	8.4mm	8.4mm	7.2mm	7.2mm	8.4mm	8.4mm	8.4mm	8.4mm	7.2mm	7.2mm	7.2mm	7.2mm	
25.4mm x 23T	70-2001	71-2001	71-3001	77-2001	77-2101	78-2001	78-2101	78-3001	78-3101	Ford, Mitsubishi, MG & Porsche			
22.5mm x 20T	70-2002	71-2002	71-3002	77-2002	77-2102	78-2002	78-2102	78-3002	78-3102	Ford, Fiat, Mitsubishi & Porsche			
24.3mm x 22T	70-2003	71-2003	71-3003	77-2003	77-2103	78-2003	78-2103	78-3003	78-3103	Mazda			
29mm x 21T	70-2004	71-2004	71-3004	77-2004	77-2104	78-2004	78-2104	78-3004	78-3104	Toyota			
25.6mm x 24T	70-2005	71-2005	71-3005	77-2005	77-2105	78-2005	78-2105	78-3005	78-3105	Nissan			
24mm x 21T	70-2006	71-2006	71-3006	77-2006	77-2106	78-2006	78-2106	78-3006	78-3106	Renault			
24mm x 21T	70-2007	71-2007	71-3007	77-2007	77-2107	78-2007	78-2107	78-3007	78-3107	Toyota			
25mm x 14T	70-2008	71-2008	71-3008	77-2008	77-2108	78-2008	78-2108	78-3008	78-3108	BMW Mini, Opel & Vauxhall			
29mm x 10T	70-2009	71-2009	71-3009	77-2009	77-2109	78-2009	78-2109	78-3009	78-3109	BMW, Ford & Mercedes			
21mm x 18T	70-2010	71-2010	71-3010	77-2010	77-2110	78-2010	78-2110	78-3010	78-3110	Peugeot			
20mm x 17T	70-2011	71-2011	71-3011	77-2011	77-2111	78-2011	78-2111	78-3011	78-3111	Ford & Fiat			
20.4mm x 24T	70-2012	71-2012	71-3012	77-2012	77-2112	78-2012	78-2112	78-3012	78-3112	Opel, Vauxhall & Volkswagen			
22mm x 19T	70-2013	71-2013	71-3013	77-2013	77-2113	78-2013	78-2113	78-3013	78-3113	Alfa Romeo			
1 1/4" x 10T	70-2014	71-2014	71-3014	77-2014	77-2114	78-2014	78-2114	78-3014	78-3114	Aston Martin, Ferrari & Triumph			
24.2 x 23T	70-2015	71-2015	71-3015	77-2015	77-2115	78-2015	78-2115	78-3015	78-3115	Audi & Volkswagen			
1 1/8" x 10T	70-2016	71-2016	71-3016	77-2016	77-2116	78-2016	78-2116	78-3016	78-3116	Jaguar, GM(USA) & Rover			
22.1mm x 28T	70-2017	71-2017	71-3017	77-2017	77-2117	78-2017	78-2117	78-3017	78-3117	Audi & Volkswagen			
29mm x 10T	70-2018	71-2018	71-3018	77-2018	77-2118	78-2018	78-2118	78-3018	78-3118	Peugeot & Renault			
19.3mm x 18T	70-2019	71-2019	71-3019	77-2019	77-2119	78-2019	78-2119	78-3019	78-3119	Suzuki			
22mm x 26T	70-2020	71-2020	71-3020	77-2020	77-2120	78-2020	78-2120	78-3020	78-3120	Renault			
19mm x 14T	70-2021	71-2021	71-3021	77-2021	77-2121	78-2021	78-2121	78-3021	78-3121	Opel & Vauxhall			
22mm x 20T	70-2022	71-2022	71-3022	77-2022	77-2122	78-2022	78-2122	78-3022	78-3122	Honda & Rover			
7/8" x 10T	70-2023	71-2023	71-3023	77-2023	77-2123	78-2023	78-2123	78-3023	78-3123	Austin Healey, Hillman, MG & Rover			
25.4mm x 24T	70-2024	71-2024	71-3024	77-2024	77-2124	78-2024	78-2124	78-3024	78-3124	Honda & Rover			
25.9mm x 24T	70-2025	71-2025	71-3025	77-2025	77-2125	78-2025	78-2125	78-3025	78-3125	Honda			
1 1/16" x 10T	70-2026	71-2026	71-3026	77-2026	77-2126	78-2026	78-2126	78-3026	78-3126	Ford (USA)			
1 5/32" x 26T	70-2027	71-2027	71-3027	77-2027	77-2127	78-2027	78-2127	78-3027	78-3127	GM (USA)			
20mm x 18T	70-2028	71-2028	71-3028	77-2028	77-2128	78-2028	78-2128	78-3028	78-3128	Nissan & Skoda			
28.7mm x 26T	70-2029	71-2029	71-3029	77-2029	77-2129	78-2029	78-2129	78-3029	78-3129	Mercedes			
1" x 10T	70-2030	71-2030	71-3030	77-2030	77-2131	78-2030	78-2130	78-3030	78-3130	Alfa Romeo, Talbot & Triumph.			
25.2mm x 24T	70-2031	71-2031	71-3031	77-2031	77-2132	78-2031	78-2131	78-3031	78-3131	Subaru			
25mm x 22T	70-2032	71-2032	71-3032	77-2032	77-2133	78-2032	78-2132	78-3032	78-3132	Volvo			
21.8mm x 20T	70-2033	71-2033	71-3033	77-2033	77-2134	78-2033	78-2133	78-3033	78-3133	Volvo			
35mm x 10T	71-2035	71-3035	71-3035	77-2033	77-2134	78-2033	78-2133	78-3033	78-3133	BMW			
28mm x 25T	71-2038	71-3038	71-3038	77-2038	77-2138	78-2038	78-2138	78-3038	78-3138	Lotus & Vauxhall			

215mm Ø Cerametallic & Organic Drive Plate Hub Spline Details.

Spline Data	Organic Sprung Hub	Organic Rigid	Organic Rigid	4 Paddle Cerametallic Sprung Hub	6 Paddle Cerametallic Sprung Hub	4 Paddle Cerametallic Rigid Hub	6 Paddle Cerametallic Rigid Hub	4 Paddle Cerametallic Rigid Hub	6 Paddle Cerametallic Rigid Hub	Application
28mm x 20T	71-2039	71-2039	71-3039	77-2039	77-2139	78-2039	78-2139	78-3039	78-3139	Toyota
22.5mm x 19T	70-2040	71-2040	71-3040	77-2040	77-2140	78-2040	78-2140	78-3040	78-3140	Toyota
1 3/8" x 10T		71-2041	71-3041			78-2041	78-2141	78-3041	78-3141	Ferrari
19mm x 17T	70-2042	71-2042	71-3042	77-2042	77-2142	78-2042	78-2142	78-3042	78-3142	SAAB
25.4mm x 23T	70-2043	71-2043	71-3043	77-2043	77-2143	78-2043	78-2143	78-3043	78-3143	Sadev Gearbox spline
29mm x 22T	70-2044	71-2044	71-3044	77-2044	77-2144	78-2044	78-2144	78-3044	78-3144	BMW
28mm x 25T	70-2045	71-2045	71-3045	77-2045	77-2145	78-2045	78-2145	78-3045	78-3145	Ferrari
20mm x 19T	70-2046	71-2046	71-3046	77-2046	77-2146	78-2046	78-2146	78-3046	78-3146	Honda
17.3mm x 20T	70-2047	71-2047	71-3047	77-2047	77-2147	78-2047	78-2147	78-3047	78-3147	Fiat, Renault
35mm x 26T	70-2048	71-2048	71-3048	77-2048	77-2148	78-2048	78-2148	78-3048	78-3148	BMW
24.5mm x 21T	70-2049	71-2049	71-3049	77-2049	77-2149	78-2049	78-2149	78-3049	78-3149	Renault
29mm x 26T	70-2050	71-2050	71-3050	77-2050	77-2150	78-2050	78-2150	78-3050	78-3150	Audi, Volkswagen
1" x 6T	70-2051	71-2051	71-3051	77-2051	77-2151	78-2051	78-2151	78-3051	78-3151	Ferrari
24.3mm x 21T	70-2052	71-2052	71-3052	77-2052	77-2152	78-2052	78-2152	78-3052	78-3152	Lotus
7/8" x 6T	70-2053	71-2053	71-3053	77-2053	77-2153	78-2053	78-2153	78-3053	78-3153	Alfa Romeo
25mm x 6T	70-2054									
34mm x 6T	70-2055	71-2055	71-3055	77-2055	77-2155	78-2055	78-2155	78-3055	71-3155	OM 1929
38mm x 10T	70-2056	71-2056	71-3056	77-2056	77-2156	78-2056	78-2156	78-3056	71-3156	Lancia
33mm x 30T	70-2057	71-2057	71-3057	77-2057	77-2157	78-2057	78-2157	78-3057	78-3157	Ferrari flywheel HF 9426
27.2mm x 10T	70-2058	71-2058	71-3058	77-2058	77-2158	78-2058	78-2158	78-3058	78-3158	Lancia

215mm Ø Cerametallic & Organic Drive Plate Hub Spline Details

Spline Data	Gearing		Hub Plate	Thickness new 7.2mm all Drive Plates	Application	
	Hub Plate	Gear				
25.4mm x 23T	Cerametallic	Gear	4 Paddle	46-1001	46-2001	Ford,Mitsubishi, MG & Porsche
22.5mm x 20T	Cerametallic	Gear	4 Paddle	46-1002	46-2002	Ford, Fiat,Mitsubishi & Porsche
24.3mm x 22T	Cerametallic	Gear	4 Paddle	46-1003	46-2003	Mazda
29mm x 21T	Cerametallic	Gear	4 Paddle	46-1004	46-2004	Toyota
25.6mm x 24T	Cerametallic	Gear	4 Paddle	46-1005	46-2005	Nissan
24mm x 21T	Cerametallic	Gear	4 Paddle	46-1006	46-2006	Renault
24mm x 21T	Cerametallic	Gear	4 Paddle	46-1007	46-2007	Toyota
25mm x 14T	Cerametallic	Gear	4 Paddle	46-1008	46-2008	BMW Mini, Opel & Vauxhall
29mm x 10T	Cerametallic	Gear	4 Paddle	46-1009	46-2009	BMW, Ford & Mercedes
21mm x 18T	Cerametallic	Gear	4 Paddle	46-1010	46-2010	Peugeot
20mm x 17T	Cerametallic	Gear	4 Paddle	46-1011	46-2011	Ford & Fiat
20.4mm x 24T	Cerametallic	Gear	4 Paddle	46-1012	46-2012	Opel,Vauxhall & Volkswagen
22mm x 19T	Cerametallic	Gear	4 Paddle	46-1013	46-2013	Alfa Romeo
1 1/4" x 10T	Cerametallic	Gear	4 Paddle	46-1014	46-2014	Aston Martin,Ferrari & Triumph
24.2 x 23T	Cerametallic	Gear	4 Paddle	46-1015	46-2015	Audi & Volkswagen
1 1/8" x 10T	Cerametallic	Gear	4 Paddle	46-1016	46-2016	Jaguar,GM(USA) & Rover
22.1mm x 28T	Cerametallic	Gear	4 Paddle	46-1017	46-2017	Audi & Volkswagen
29mm x 10T	Cerametallic	Gear	4 Paddle	46-1018	46-2018	Peugeot & Renault
19.3mm x 18T	Cerametallic	Gear	4 Paddle	46-1019	46-2019	Suzuki
22mm x 26T	Cerametallic	Gear	4 Paddle	46-1020	46-2020	Renault
19mm x 14T	Cerametallic	Gear	4 Paddle	46-1021	46-2021	Opel & Vauxhall
22mm x 20T	Cerametallic	Gear	4 Paddle	46-1022	46-2022	Honda & Rover
7/8" x 10T	Cerametallic	Gear	4 Paddle	46-1023	46-2023	Austin Healey,Hillman, MG & Rover
25.4mm x 24T	Cerametallic	Gear	4 Paddle	46-1024	46-2024	Honda & Rover
25.9mm x 24T	Cerametallic	Gear	4 Paddle	46-1025	46-2025	Honda
1 1/16" x 10T	Cerametallic	Gear	4 Paddle	46-1026	46-2026	Ford (USA)
1 5/32" x 26T	Cerametallic	Gear	4 Paddle	46-1027	46-2027	GM (USA)
20mm x 18T	Cerametallic	Gear	4 Paddle	46-1028	46-2028	Nissan & Skoda
28.7mm x 26T	Cerametallic	Gear	4 Paddle	46-1029	46-2029	Mercedes
1" x 10T	Cerametallic	Gear	4 Paddle	46-1030	46-2030	Alfa Romeo, Talbot & Triumph.
25.2mm x 24T	Cerametallic	Gear	4 Paddle	46-1031	46-2031	Subaru
25mm x 22T	Cerametallic	Gear	4 Paddle	46-1032	46-2032	Volvo
21.8mm x 20T	Cerametallic	Gear	4 Paddle	46-1033	46-2033	Volvo
35mm x 10T	Cerametallic	Gear	4 Paddle	46-1035	46-2035	BMW
28mm x 25T	Cerametallic	Gear	4 Paddle	46-1038	46-2038	Lotus & Vauxhall

215mm Ø Cerametallic & Organic Drive Plate Hub Spline Details

Spline Data	Geared			Application
	Hub Plate	Geared Hub Plate	Geared Hub Plate	
	Cerametallic 4 Paddle	Cerametallic 6 Paddle	Organic Plate	Thickness new 7.2mm all Drive Plates
Ø Teeth				
28mm x 20T	46-1039	46-1139	46-2039	Toyota
22.5mm x 19T	46-1040	46-1140	46-2040	Toyota
1 3/8" x 10T	46-1041	46-1141	46-2041	Ferrari
19mm x 17T	46-1042	46-1142	46-2042	SAAB
25.4mm x 23T	46-1043	46-1143	46-2043	Sadev Gearbox spline
29mm x 22T	46-1044	46-1144	46-2044	BMW
28mm x 25T	46-1045	46-1145	46-2045	Ferrari
20mm x 20T	46-1046	46-1146	46-2046	Honda
17.3mm x 20T	46-1047	46-1147	46-2047	Fiat, Renault
35mm x 26T	46-1048	46-1148	46-2048	BMW
24.5mm x 21T	46-1049	46-1149	46-2049	Renault
29mm x 26T	46-1050	46-1150	46-2050	Audi, Volkswagen
1" x 6T	46-1051	46-1151	46-2051	Ferrari
24.3mm x 21T	46-1052	46-1152	46-2052	Lotus
7/8" x 6T	46-1053	46-1153	46-2053	Alfa Romeo
25mm x 6T	46-1054	46-1154	46-2054	
34mm x 6T	46-1055	46-1155	46-2055	OM 1929
38mm x 10T	46-1056	46-1156	46-2056	Lancia
33mm x 30T	46-1057	46-1157	46-2057	Ferrari flywheel HF 9476
27.2mm x 10T	46-1058	46-1158	46-2058	Lancia Astura
Geared Floating Plate	46-1090	46-1091	46-1092	Geared Floating Plate